

SMB8105-0179

SMB Jack Crimp For Bulkhead 75Ω

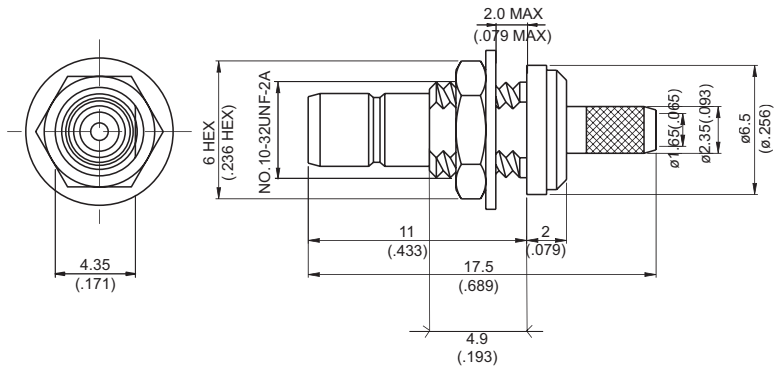

MOUNTING HOLE

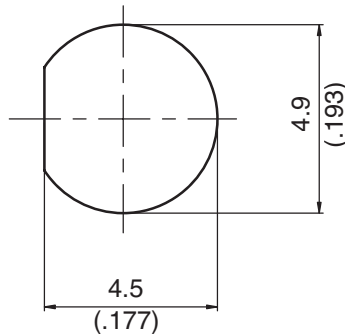

NOTE: 75Ω MINI SMB INTERFACE

Parts	Material	Plating (Micro-inch)
Hex Nut	Brass	Gold 5 Over Nickel 50 Over Copper 50
Lock Washer	Brass	Gold 5 Over Nickel 50 Over Copper 50
Ferrule	Brass	Gold 5 Over Nickel 50 Over Copper 50
Contact Pin	Brass	Gold 20 Over Nickel 50 Over Copper 50
Insulator	Teflon	
Barrel	Brass	Gold 5 Over Nickel 50 Over Copper 50
Body	Brass	Gold 5 Over Nickel 50 Over Copper 50

Weight:

Suitable Cables: RG179, RG179-FEP

This part number complies with RoHS.

Notice: JYEBAO reserves the right to make modifications deemed appropriate.

CABLE ASSEMBLY INSTRUCTION

SMB8105-0179

JYE BAO CO., LTD.

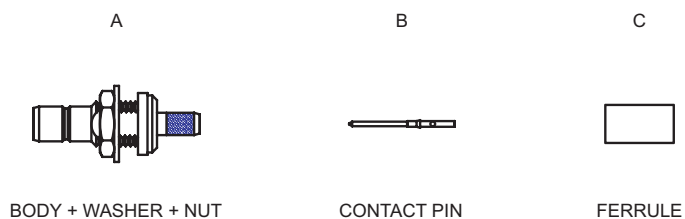
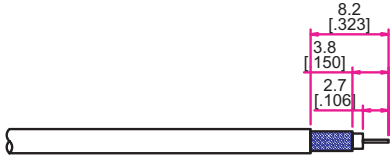
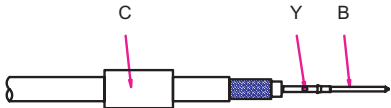
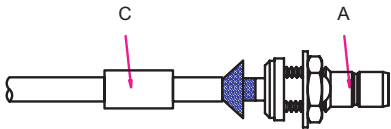
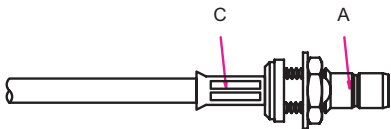

DIAGRAM	ASSEMBLY INSTRUCTION
	Step 1: STRIP AS SHOWN .
	Step 2: SLIDE FERRULE " C " OVER CABLE. Step 3: PUT PIN " B " ON CENTER CONDUCTOR AND SOLDER IN " Y " .
	Step 4: LOOSEN BRAIDING AND SLIDE CONNECTOR " A " IN PLACE.
	Step 5: SLIDE FERRULE " C " TOWARDS THE CONNECTOR " A " AND CRIMP.

This part number complies with RoHS.

Notice: JYEBAO reserves the right to make modifications deemed appropriate.