



P.O. Box 130, Frenchtown, NJ 08825
 Phone 1-908-996-6841
 FAX 1-908-996-3891

LO-PRO® file STRIP-LINE Sockets PIN LINE COLLET Socket

Pin Line sockets can be snapped apart into any required number of pins without damage or loss of pins. Pin Line sockets are low profile and used for mounting devices with .100 (2,54) spacing between pins. Rows of socket strips may be mounted on any centers or side-by-side for .100 (2,54) grid or matrix patterns. Strips also butt end-to-end and maintain .100 (2,54) spacing.

SPECIFICATIONS

- Collet accepts: .015 (0,38) - .022 (0,55) dia. round leads
- Contacts: Collet—Beryllium copper
Body—Brass
- Plating: Tin collet/tin shell, gold collet/tin shell and gold collet/gold shell are all available. See page 4 for details.
- Platform: Glass filled thermoplastic

*Last digit indicates plating: 0 = 100µ (2,54µm) Tin
 1 = 10µ (0,25µm) Gold over Nickel

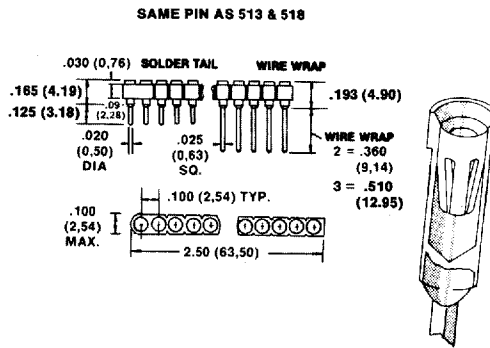

HOW TO ORDER

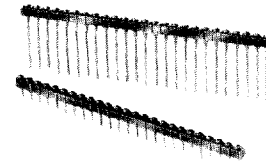
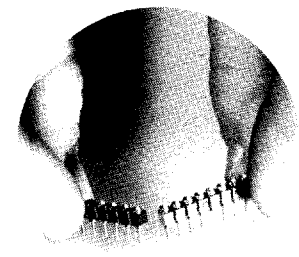
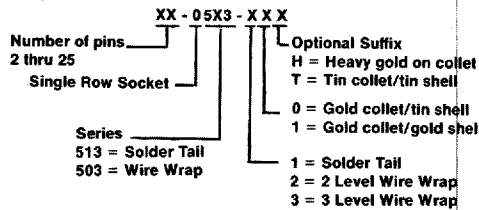

PIN-LINE Collet Contacts with "Break" Feature
 2 to 25 positions

Series 0520 Lo-Pro® file STRIP-LINE SOCKETS

- VERY COMPETITIVELY PRICED!
- 40 pins/sockets per strip
- Excellent insertion and withdrawal forces
- Tin plated - 100µ (2,54µm) min. thickness in contact area
- Stamped single beam face-grip contacts
- Body meets flammability spec UL 94V-0
- Wide temperature range from -40°C to +75°C
- Anti-solder wicking design
- Accepts IC lead thickness from .006 (0,15) to .015 (0,38)
- Gas tight contact system which withstands environment testing
- Copper alloy 688 contacts

HOW TO ORDER:

Series 0520 STRIP-LINE Sockets can be ordered to any number of contacts or socket positions from 2 to 40.

Note: Series 0520 is black in color.

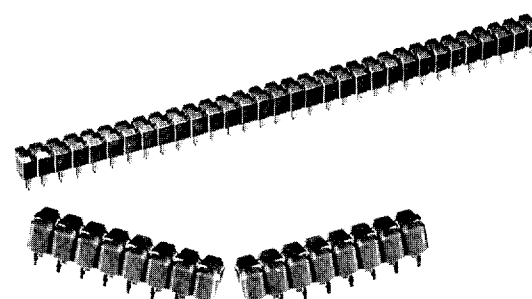
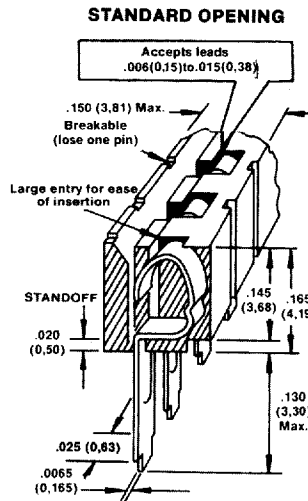
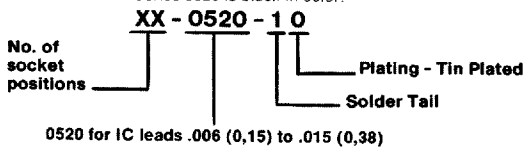

IT'S BREAKABLE: Just break to number of contact positions wanted.
 NOTE: When broken, one socket position is lost.

Series 0520 LO-PRO® file STRIP-LINE SOCKETS
 40 pins/sockets per strip

Series 0525 LO-PRO® file STRIP LINE SOCKETS

Series 0525 STRIP-LINE SOCKETS with "break" feature are priced for high volume use wherever single in-line sockets are needed, such as: components using .025 (0,63) sq. pins or plug-in jumpers. Series 0525 STRIP-LINE sockets can be ordered to any number of socket positions from 2 to 40; or with the "break" feature, can be broken off to any desired number of socket positions from the full strip of 40 sockets.

SPECIFICATIONS

- Tin plated- 100µ (2,54µm) min. thickness in contact area.
- Stamped single beam strip contacts.
- Body meets flammability spec. UL94VO.
- Wide temperature range from -40°C to +75°C.
- Gas tight contact system which withstands environment testing.
- Copper alloy 688 contacts.
- Accepts leads .015 (0,38) to .025 (0,63)

HOW TO ORDER

Series 0525 STRIP-LINE sockets can be ordered to any number of socket positions from 2 to 40.

Note: Series 0525 is blue in color.

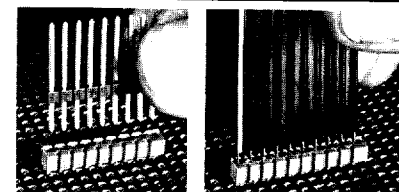
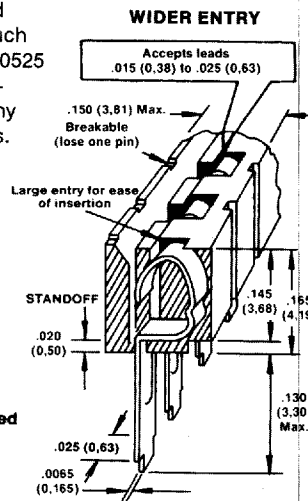
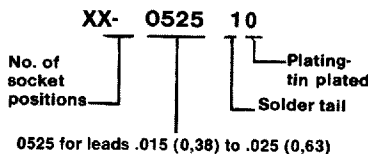

IT'S BREAKABLE: Just break to number of contact positions wanted.
 NOTE: When broken, one socket position is lost.

Series 0525 LO-PRO® file STRIP-LINE SOCKETS
 40 pins/sockets per strip