

200kbps Fiber Optic Receiver

Type OPF500, OPF510 Series

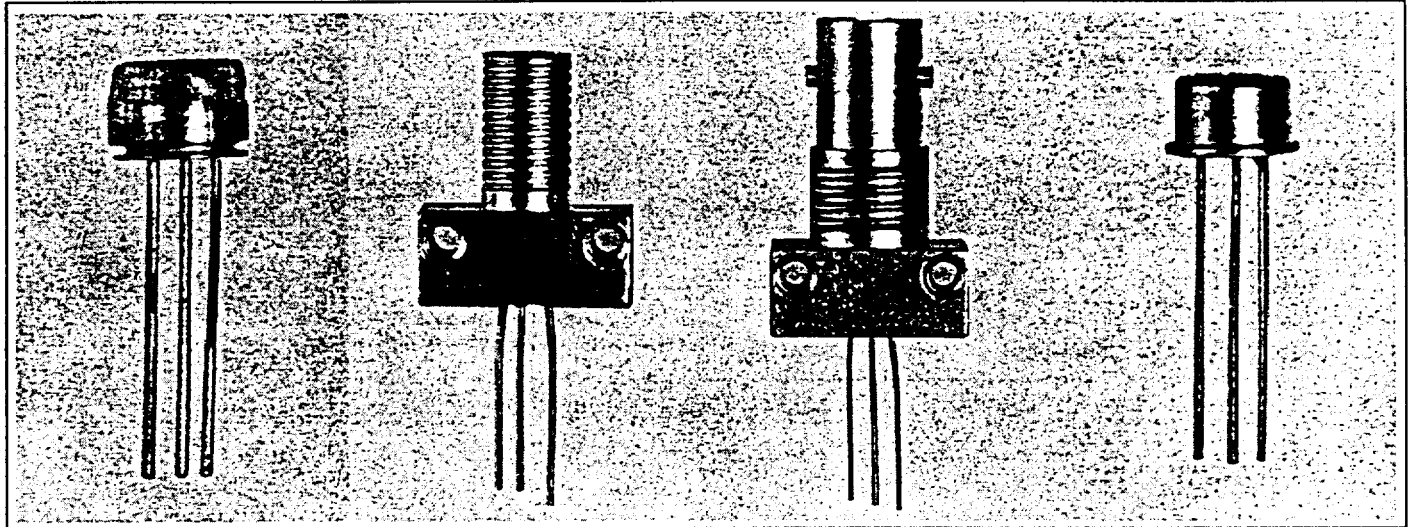

Features

- Interfaces with all logic circuits
- Two output options
- Optimized for fiber optic applications using 50 to 200 micron fiber
- Data rate to 200kbps NRZ
- Available with multiple packaging options

Description

The OPF500, OPF510 series receiver contains a monolithic integrated circuit which incorporates a photodiode, a linear amplifier, a voltage regulator and a Schmitt trigger on a single silicon chip. These receivers are designed for short haul fiber optic systems using 850 nm LED's such as Optek's OPF300 series.

These devices feature TTL/LSTTL compatible logic level output. An internal voltage regulator allows operation with supply voltages ranging from 4.5 V to 16 V.

Absolute Maximum Ratings ($T_A = 25^\circ\text{C}$ unless otherwise noted)

Supply Voltage	18 V
Storage Temperature Range	-65°C to $+100^\circ\text{C}$
Operating Temperature Range	-40°C to $+85^\circ\text{C}$
Lead Soldering Temperature [1/16 inch (1.6 mm) from case for 5 sec. with soldering iron]	240°C
Power Dissipation	200 mW
Duration of Output Short to V_{CC}	1 sec.
Voltage at Output	30 V
Sinking Current	16 mA

Schematics

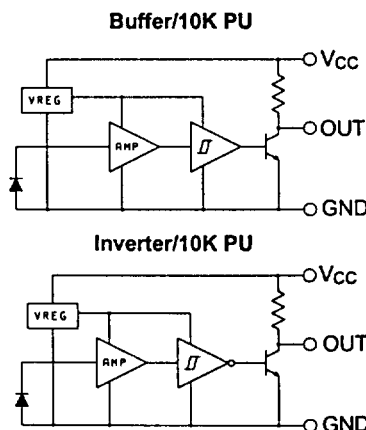

Type OPF500, OPF510 Series

Electrical Characteristics (-40° C to +85° C unless otherwise noted)

SYMBOL	PARAMETER	MIN	TYP	MAX	UNITS	TEST CONDITIONS
V _{CC}	Operating Supply Voltage	4.5		16.0	V	
P _{IN}	Input Sensitivity (OPF5X0,1,2)		1.0	1.5	μW	50% Duty Cycle Square Wave
P _{IN}	Input Sensitivity (OPF5X5,6,7)		1.5	2.0	μW	50% Duty Cycle Square Wave
V _{OH}	High Level Output Voltage Buffer 10K Pull-up	V _{CC} -1.5			V	P _{IN} > 2.0 μW, V _{CC} = 4.5 V to 16 V
	Inverter 10K Pull-up	V _{CC} -1.5			V	P _{IN} < 0.1 μW, V _{CC} = 4.5 V to 16 V
V _{OL}	Low Level Output Voltage Buffer, 10K Pull-up Buffer Open-collector			0.4	V	P _{IN} < 0.1 μW, V _{CC} = 4.5 V to 16 V
	Inverter, 10K Pull-up Inverter Open-collector			0.4	V	P _{IN} > 2.0 μW, V _{CC} = 4.5 V to 16 V
I _{CC}	Supply Current		5.0	12.0	mA	V _{CC} = 4.5 V to 16 V, No load on output
BW	Bandwidth	200			kHz	P _{IN} > 2.0 μW, 50% Duty Cycle
PWD	Pulse With Distortion			10	%	1 μW < P _{IN} < 100 μW, f = 20 kHz, D.C. = 50%
t _r	Buffer			300	ns	P _{IN} = 1.5 μW, V _{CC} = 5 V
t _f				100	ns	
t _r	Inverter			100	ns	P _{IN} = 1.5 μW, V _{CC} = 5 V
t _f				300	ns	

PART NUMBER GUIDE

OPF5XX

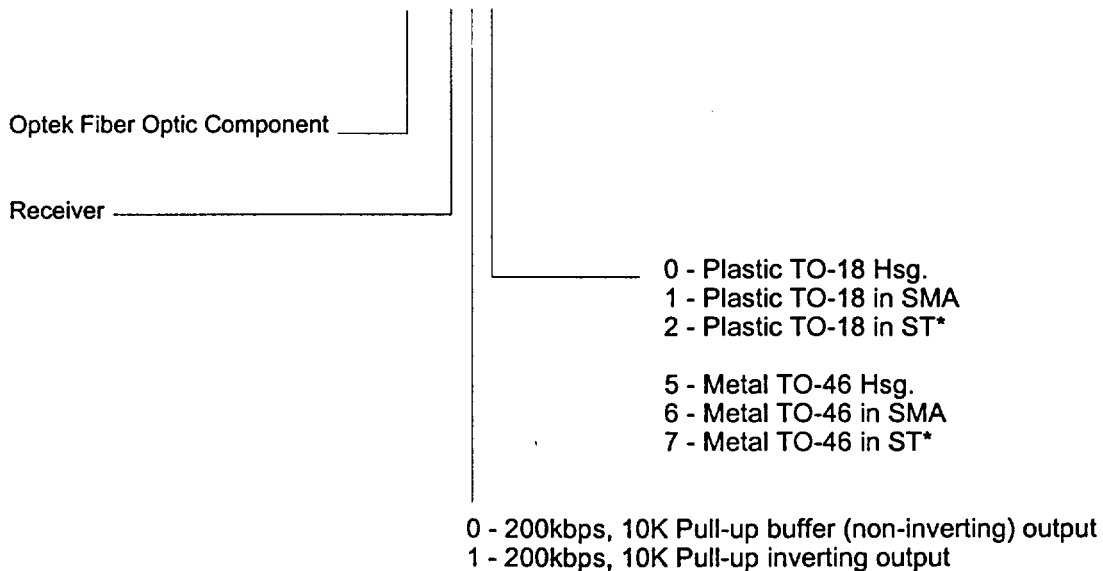

ST* is a registered trademark of AT&T.

Optek reserves the right to make changes at any time in order to improve design and supply the best product possible.

Optek Technology, Inc. 1215 W. Crosby Road Carrollton, Texas 75006 (972) 323-2200 Fax (972) 323-2396

Typical Performance Curves

High Level Output Voltage vs. Ambient Temperature

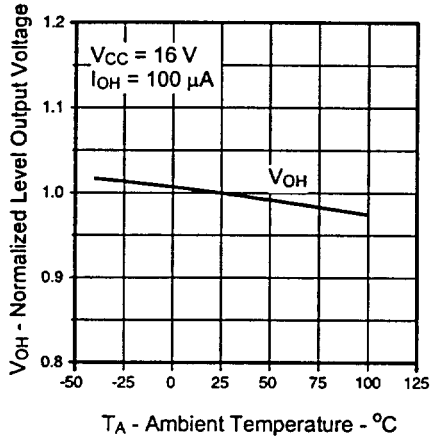

High Level Output Current vs. Ambient Temperature

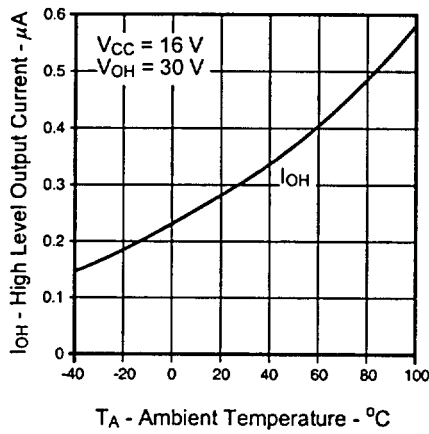

Low Level Output Voltage vs. Ambient Temperature

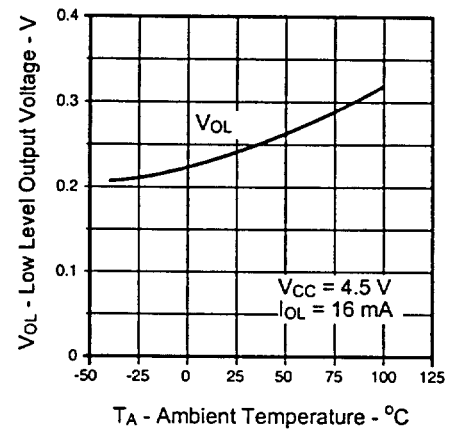

Type OPF500, OPF510 Series

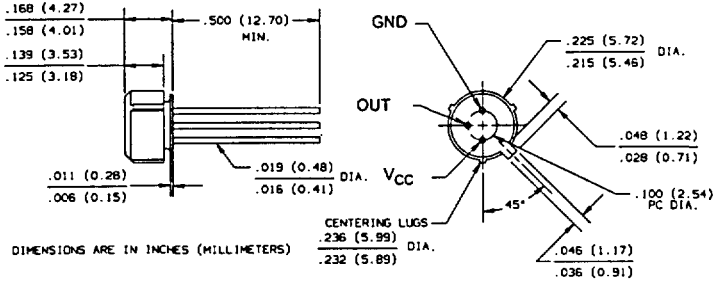

Plastic Package

OPF500, OPF510

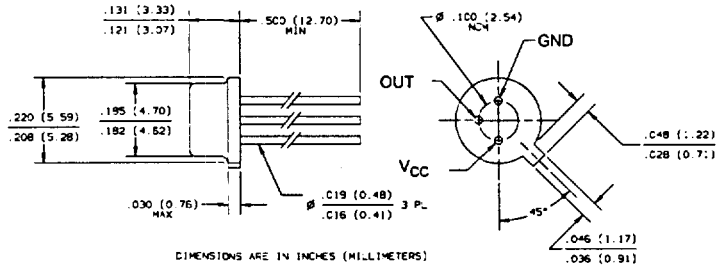

Hermetic Package

OPF505, OPF515

SMA Package

OPF501, OPF511
OPF506, OPF516

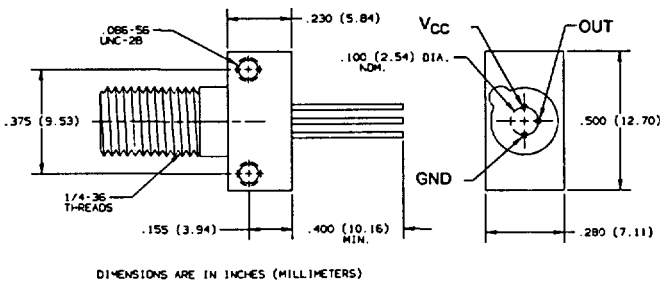

ST* Package

OPF502, OPF512
OPF507, OPF517

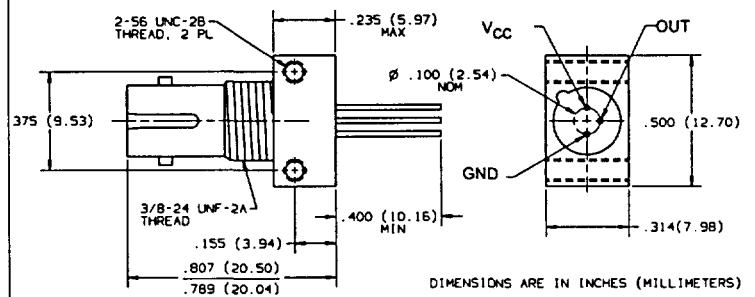

ST* is a registered trademark of AT&T.