

# Low power dual voltage comparator

AU2903

## DESCRIPTION

The AU2903 consists of two independent precision voltage comparators with an offset voltage specification as low as 2.0mV max. for two comparators which were designed specifically to operate from a single power supply over a wide range of voltages. Operation from split power supplies is also possible and the low power supply current drain is independent of the magnitude of the power supply voltage. These comparators also have a unique characteristic in that the input common-mode voltage range includes ground, even though operated from a single power supply voltage.

## FEATURES

- Wide single supply voltage range 2.0V<sub>DC</sub> to 36V<sub>DC</sub> or dual supplies  $\pm 1.0V_{DC}$  to  $\pm 18V_{DC}$
- Very low supply current drain (0.8mA) independent of supply voltage (2.0mW/comparator at 5.0V<sub>DC</sub>)
- Low input biasing current 25nA
- Low input offset current  $\pm 5nA$  and offset voltage  $\pm 2mV$
- Input common-mode voltage range includes ground
- Differential input voltage range equal to the power supply voltage
- Low output 250mV at 4mA saturation voltage
- Output voltage compatible with TTL, DTL, ECL, MOS and CMOS logic systems

## PIN CONFIGURATION

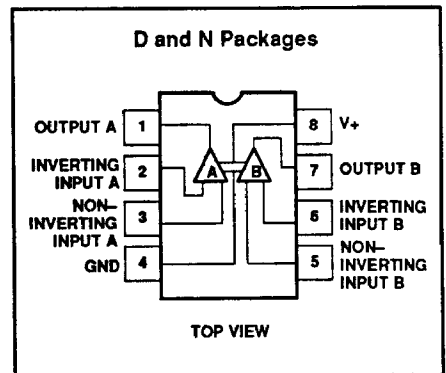

## APPLICATIONS

- A/D converters
- Wide range VCO
- MOS clock generator
- High voltage logic gate
- Multivibrators

## EQUIVALENT CIRCUIT

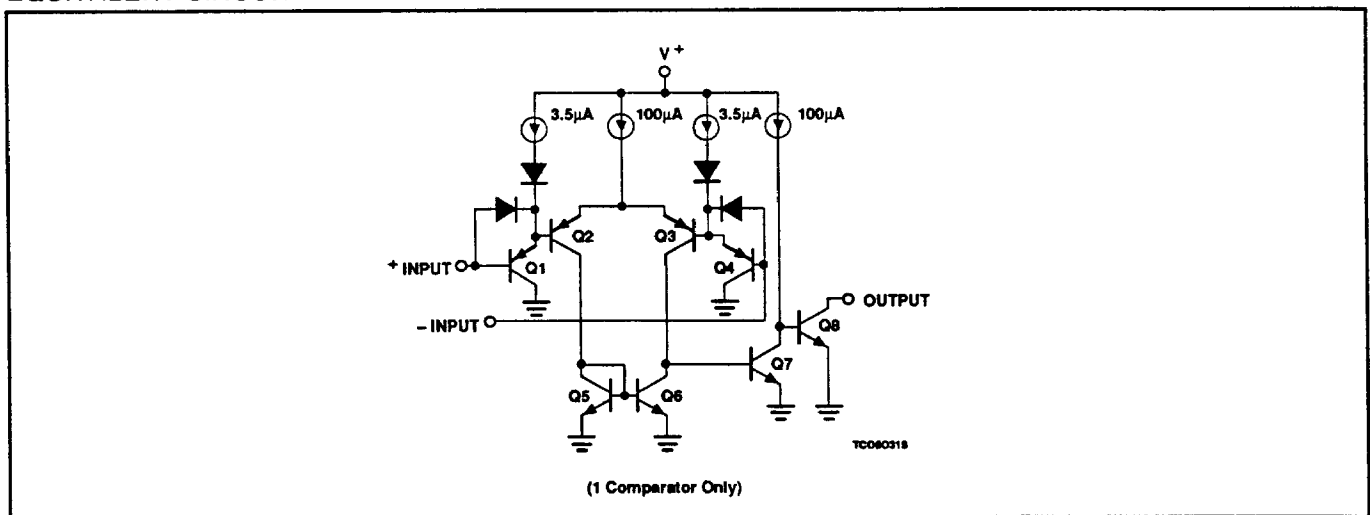

## Low power dual voltage comparator

AU2903

## ORDERING INFORMATION

DESCRIPTION	TEMPERATURE RANGE	ORDER CODE
8-Pin Plastic SO	-40°C to +125°C	AU2903D
8-Pin Plastic DIP	-40°C to +125°C	AU2903N

## ABSOLUTE MAXIMUM RATINGS

SYMBOL	PARAMETER	RATING	UNIT
$V_{CC}$	Supply voltage	36 or $\pm 18$	$V_{DC}$
	Differential input voltage	36	$V_{DC}$
$V_{IN}$	Input voltage	-0.3 to +36	$V_{DC}$
$P_{DMAX}$	Maximum power dissipation, $T_A=25^\circ\text{C}$ (still-air) <sup>3</sup> N package D package	1160 780	mW mW
	Output short-circuit to ground <sup>1</sup>	Continuous	
$I_{IN}$	Input current ( $V_{IN} < -0.3V_{DC}$ ) <sup>2</sup>	50	mA
$T_A$	Operating temperature range AU2903	-40 to +125	°C
$T_{STG}$	Storage temperature range	-65 to +150	°C
$T_{SOLD}$	Lead soldering temperature (10sec max)	300	°C

## NOTES:

- Short circuits from the output to  $V_+$  can cause excessive heating and eventual destruction. The maximum output current is approximately 20mA independent of the magnitude of  $V_+$ .
- This input current will only exist when the voltage at any of the input leads is driven negative. It is due to the collector-base junction of the input PNP transistors becoming forward biased and thereby acting as input diode clamps. In addition to this diode action, there is also lateral NPN parasitic transistor action on the IC chip. This transistor action can cause the output voltages of the comparators to go to the  $V_+$  voltage level (or to ground for a large overdrive) for the time duration that an input is driven negative. This is not destructive and normal output states will re-establish when the input voltage, which was negative, again returns to a value greater than  $-0.3V_{DC}$ .
- Derate above 25°C, at the following rates:  
N package at 9.3mW/°C  
D package at 6.2mW/°C

## Low power dual voltage comparator

AU2903

## DC AND AC ELECTRICAL CHARACTERISTICS

 $V_+ = 5V_{DC}$ , AU2903;  $-40^\circ\text{C}$ ,  $T_A \leq +125^\circ\text{C}$ , unless otherwise specified.

SYMBOL	PARAMETER	TEST CONDITIONS	AU2903			UNIT
			Min	Typ	Max	
$V_{OS}$	Input offset voltage <sup>2</sup>	$T_A = 25^\circ\text{C}$ Over temp.		$\pm 2.0$ $\pm 9$	$\pm 7.0$ $\pm 15$	mV
$V_{CM}$	Input common-mode voltage range <sup>3, 6</sup>	$T_A = 25^\circ\text{C}$ Over temp.	0 0		$V_+ - 1.5$ $V_+ - 2.0$	V
$V_{IDR}$	Differential input voltage <sup>1</sup>	Keep all $V_{INs} \geq 0V_{DC}$ (or $V_-$ if need)			$V_+$	V
$I_{BIAS}$	Input bias current <sup>4</sup>	$I_{IN(+)}$ or $I_{IN(-)}$ with output in linear range $T_A = 25^\circ\text{C}$ Over temp.		25 200	250 500	nA
$I_{OS}$	Input offset current	$I_{IN(+)} - I_{IN(-)}$ $T_A = 25^\circ\text{C}$ Over temp.		$\pm 5$ $\pm 50$	$\pm 50$ $\pm 200$	nA nA
$I_{OL}$	Output sink current	$V_{IN(-)} \geq 1V_{DC}$ , $V_{IN(+)} = 0$ , $V_O \leq 1.5V_{DC}$ $T_A = 25^\circ\text{C}$	6.0	16		mA
$I_{OH}$	Output leakage current	$V_{IN(+)} \geq 1V_{DC}$ , $V_{IN(-)} = 0$ $V_O = 5V_{DC}$ , $T_A = 25^\circ\text{C}$ $V_O = 30V_{DC}$ , over temp.		0.1	1.0	nA $\mu\text{A}$
$I_{CC}$	Supply current	$R_L = \infty$ on both comparators. $T_A = 25^\circ\text{C}$ $V_+ = 30V$ , over temp.		0.8 1	1 2.5	mA
$A_V$	Voltage gain	$R_L \geq 15k\Omega$ , $V_+ = 15V_{DC}$ , $T_A = 25^\circ\text{C}$	25	100		V/mV
$V_{OL}$	Saturation voltage	$V_{IN(-)} \geq 1V_{DC}$ , $V_{IN(+)} = 0$ , $I_{SINK} \leq 4\text{mA}$ $T_A = 25^\circ\text{C}$ Over temp.		400	400 700	mV
$t_{LSR}$	Large-signal response time	$V_{IN} = \text{TTL logic swing}$ , $V_{REF} = 1.4V_{DC}$ $V_{RL} = 5V_{DC}$ , $R_L = 5.1k\Omega$ , $T_A = 25^\circ\text{C}$		300		ns
$t_R$	Response time <sup>5</sup>	$V_{RL} = 5V_{DC}$ , $R_L = 5.1k\Omega$ $T_A = 25^\circ\text{C}$		1.3		$\mu\text{s}$

## NOTES:

- Positive excursions of input voltage may exceed the power supply level by 17V. As long as the other voltage remains within the common-mode range, the comparator will provide a proper output state. The low input voltage state must not be less than  $-0.3V_{DC}$  ( $V_{DC}$  below the magnitude of the negative power supply, if used).
- At output switch point,  $V_O = 1.4V_{DC}$ ,  $R_S = 0\Omega$  with  $V_+$  from  $5V_{DC}$  to  $30V_{DC}$  and over the full input common-mode range ( $0V_{DC}$  to  $V_+ - 1.5V_{DC}$ ).
- The input common-mode voltage or either input signal voltage should not be allowed to go negative by more than 0.3V. The upper end of the common-mode voltage range is  $V_+ - 1.5V$ , but either or both inputs can go to  $30V_{DC}$  without damage.
- The direction of the input current is out of the IC due to the PNP input stage. This current is essentially constant, independent of the state of the output so no loading change exists on the reference or input lines.
- The response time specified is for a 100mV input step with a 5mV overdrive.
- For input signals that exceed  $V_{CC}$ , only the overdriven comparator is affected. With a 5V supply,  $V_{IN}$  should be limited to 25V maximum, and a limiting resistor should be used on all inputs that might exceed the positive supply.

# Low power dual voltage comparator

AU2903

## TYPICAL APPLICATIONS

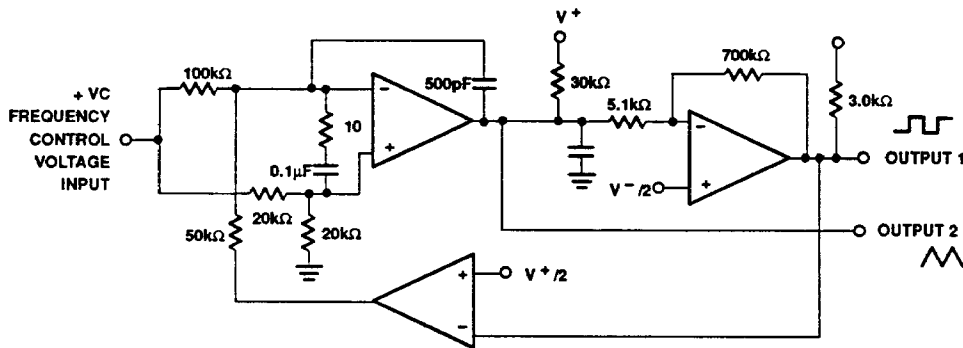

**NOTES:**  
 $V_+ = 30V_{DC}$   
 $+250mV_{DC} \leq V_C \leq 50V_{DC}$   
 $700Hz \leq f_O = 100kHz$

Two-Decade High-Frequency VCO

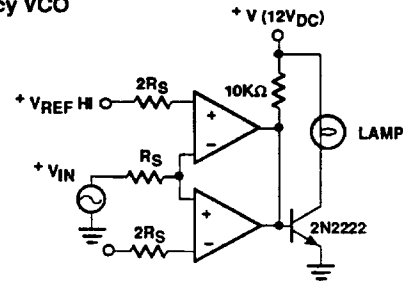

Limit Comparator

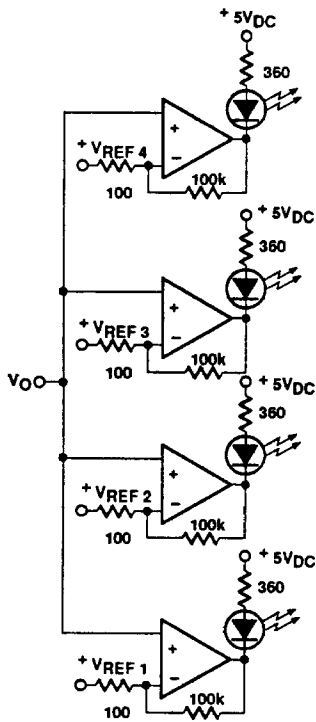

Visible Voltage Indicator

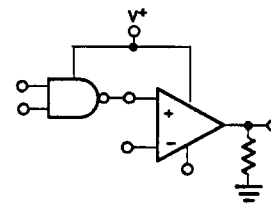

TTL-to-MOS Logic Converter

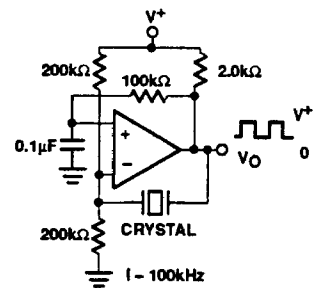

Crystal-Controlled Oscillator

**NOTE:**  
 Input of unused comparators should be grounded.

# Low power dual voltage comparator

AU2903

## TYPICAL PERFORMANCE CHARACTERISTICS

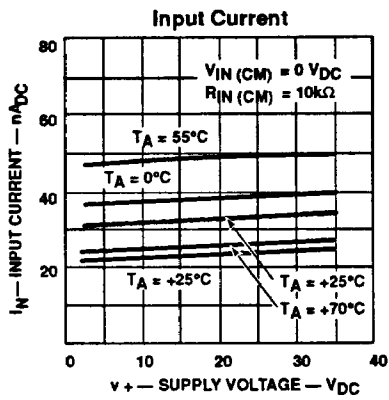

OP065009

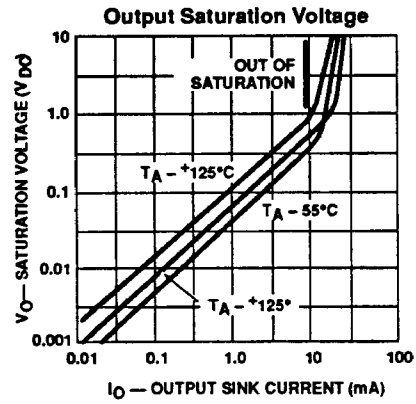

OP065009

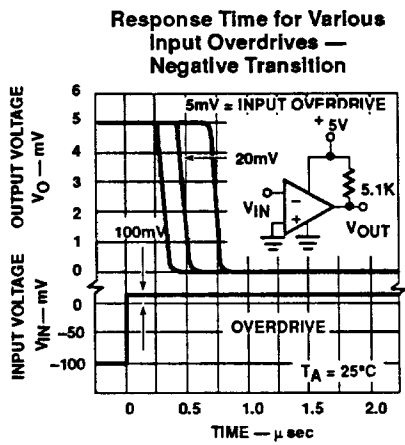

OP065009

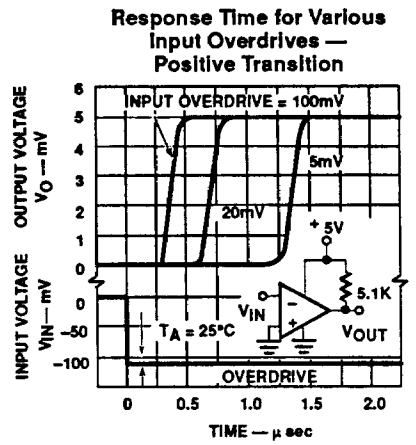

OP065109