

512KB and 1MB BurstRAM Secondary Cache Modules for PowerPC™ PReP/CHRP Platforms

The MPC2105C and the MPC2106C are designed to provide burstable, high performance L2 cache for the PowerPC 60x microprocessor family in conformance with the PowerPC Reference Platform (PReP) and the PowerPC Common Hardware Reference Platform (CHRP) specifications.

The MPC2105C and MPC2106C utilize synchronous BurstRAMs. The modules are configured as 64K x 72, and 128K x 72 bits in a 178 (89 x 2) pin DIMM format. The MPC2105C uses four of the 3 V 64K x 18; the MPC2106C uses eight of the 3 V 64K x 18. For tag bits, a 5 V cache tag RAM configured as 16K x 12 for tag field plus 16K x 2 for valid and dirty status bits is used.

Bursts can be initiated with the ADS signal. Subsequent burst addresses are generated internal to the BurstRAM by the CNTEN signal.

Write cycles are internally self timed and are initiated by the rising edge of the clock (CLKx) inputs. Eight write enables are provided for byte write control.

Presence detect pins are available for auto configuration of the cache control.

The module family pinout will support 5 V and 3.3 V components for a clear path to lower voltage and power savings. Both power supplies must be connected.

All of these cache modules are plug and pin compatible with each other.

- PowerPC-style Burst Counter on Chip
- Flow-Through Data I/O
- Plug and Pin Compatibility
- Multiple Clock Pins for Reduced Loading
- All Cache Data and Tag I/Os are LVTTTL (3.3 V) Compatible
- Three State Outputs
- Byte Write Capability
- Fast Module Clock Rates: Up to 66 MHz
- Fast SRAM Access Times: 10 ns for Tag RAM Match
9 ns for Data RAM
- Decoupling Capacitors for Each Fast Static RAM
- High Quality Multi-Layer FR4 PWB With Separate Power and Ground Planes
- 178 Pin Card Edge Module
- Burndy Connector, Part Number: ELF178KSC-3Z50

MPC2105C MPC2106C

178-LEAD CARD EDGE
TOP VIEW
MPC2105C CASE 1132A-01
MPC2106C CASE 1132-01

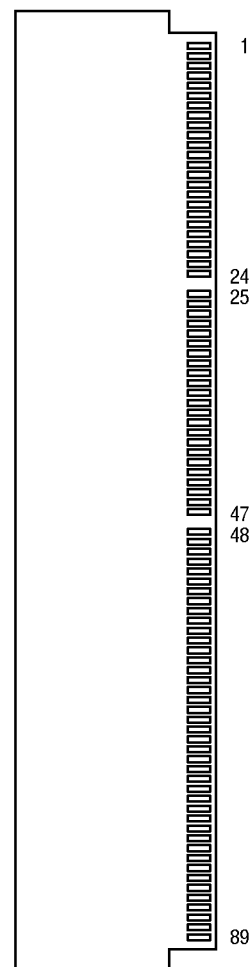

The PowerPC name is a trademark of IBM Corp., used under license therefrom.

MPC2105C BLOCK DIAGRAM

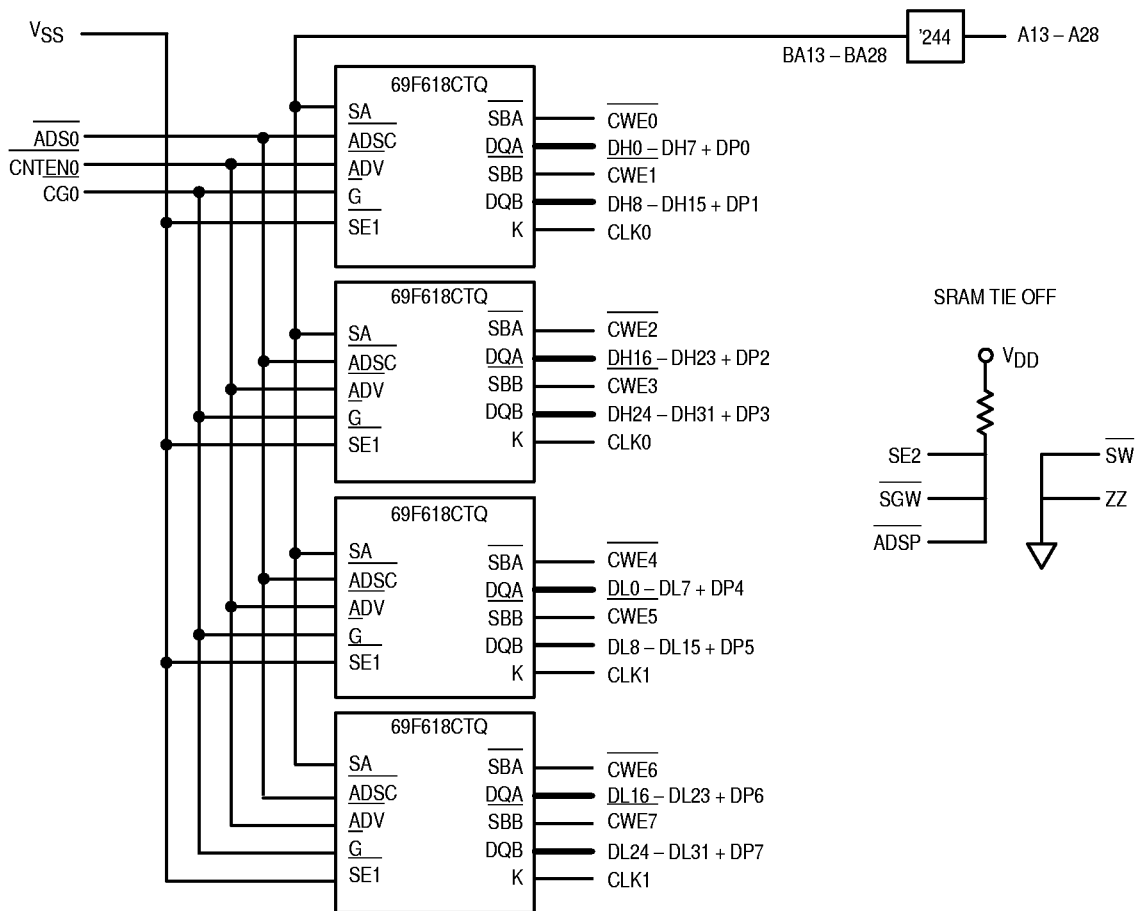

SRAM TIE OFF

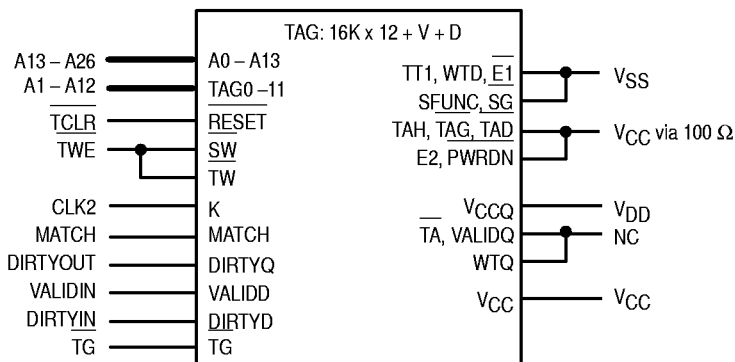
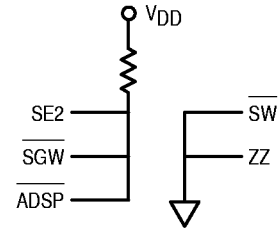

- A0 = NC
- CLK3 = NC
- CLK4 = NC
- \overline{ALE} = NC
- $\overline{ADS1}$ = NC
- $\overline{CNTEN1}$ = NC
- CG1 = NC
- ADDR0 = NC
- ADDR1 = NC

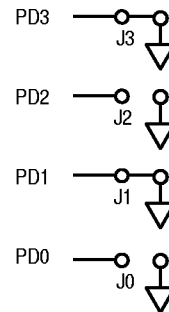

Note: BA28 is tied to SA0 on SRAM;
 BA27 is tied to SA1 on SRAM;
 STANDBY is tied to SE3 on SRAM.

MPC2106C BLOCK DIAGRAM

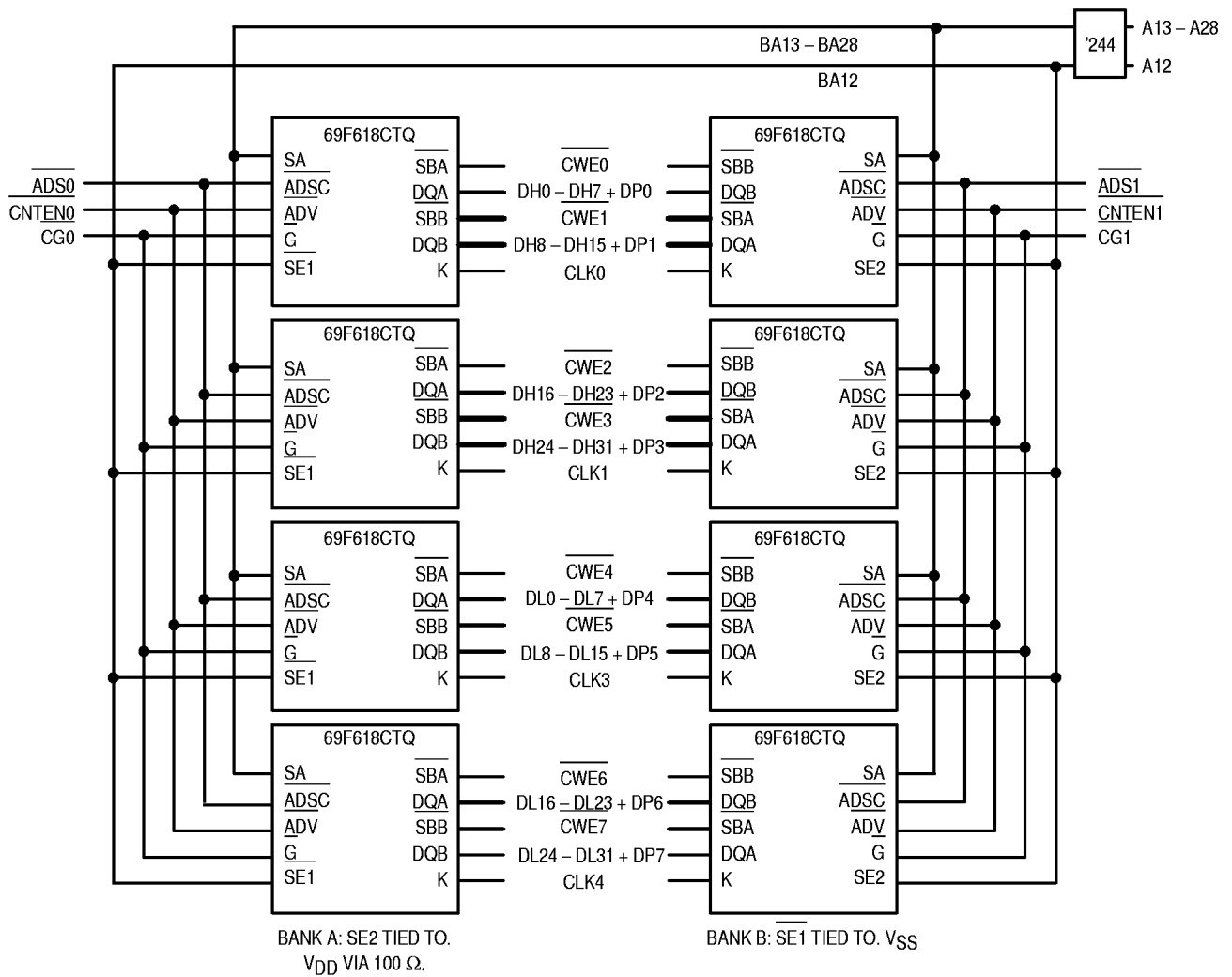

SRAM TIE OFF

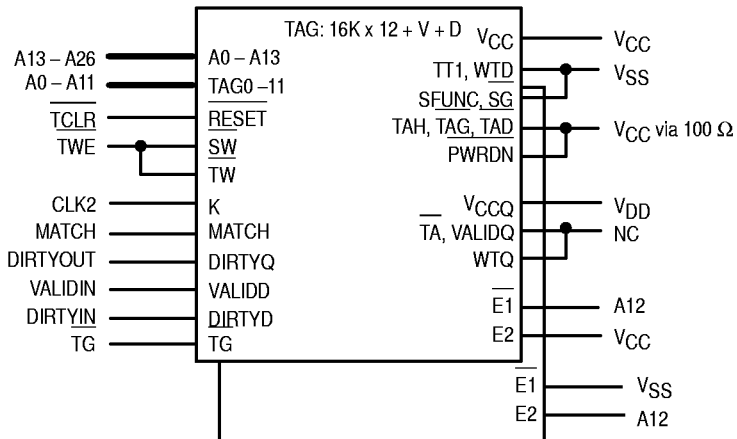

Note: BA28 is tied to SA0 on SRAM;
 BA27 is tied to SA1 on SRAM;
 STANDBY is tied to SE3 on SRAM.

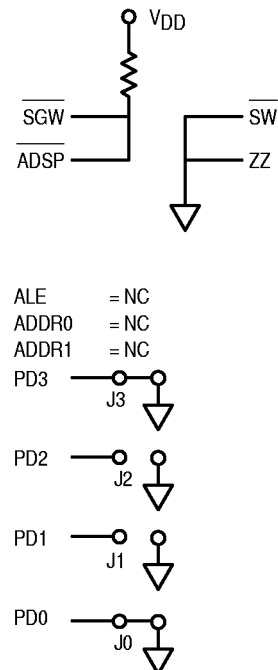

PIN ASSIGNMENT
178-LEAD DIMM
TOP VIEW

VSS	90	1	VSS
PD1/IDSDATA	91	2	PD0/IDSCCLK
PD3	92	3	PD2
DH31	93	4	DH30
DH29	94	5	DH28
DH27	95	6	DH26
DH25	96	7	DH24
VDD	97	8	VDD
CWE3	98	9	DP3
DH23	99	10	DH22
DH21	100	11	DH20
DH18	101	12	DH19
VSS	102	13	VSS
DH16	103	14	DH17
CWE2	104	15	DP2
DH14	105	16	DH15
DH13	106	17	DH12
VCC	107	18	VCC
DH10	108	19	DH11
DH8	109	20	DH9
CEW1	110	21	DP1
DH6	111	22	DH7
VDD	112	23	VDD
DH4	113	24	DH5
VSS	114	25	DH3
CLK0	115	26	DH2
VSS	116	27	DH0
DH1	117	28	DP0
CWE0	118	29	VSS
DL31	119	30	CLK1
DL30	120	31	VSS
VSS	121	32	DL28
DL29	122	33	DL26
DL27	123	34	DL24
DL25	124	35	DP7
VCC	125	36	VCC
CWE7	126	37	DL22
DL23	127	38	DL20
DL21	128	39	DL18
DL19	129	40	DL16
VSS	130	41	VSS
DL17	131	42	DP6
CWE6	132	43	DL14
DL15	133	44	DL12
DL13	134	45	DL11
VSS	135	46	VSS
DL10	136	47	DL9

DL8	137	48	DP5
CWE5	138	49	DL7
DL6	139	50	DL4
VDD	140	51	VDD
DL5	141	52	DL3
DL2	142	53	DL1
VSS	143	54	DL0
CLK3	144	55	VSS
VSS	145	56	CLK2
CLK4	146	57	VSS
VSS	147	58	DP4
CWE4	148	59	CG0
ALE	149	60	CG1
VDD	150	61	VDD
ADDR1	151	62	ADDR0
RESERVED	152	63	RESERVED
CNTEN0	153	64	ADS0
CNTEN1	154	65	ADS1
A27	155	66	A28
A24	156	67	A26
A22	157	68	A25
A20	158	69	A23
VSS	159	70	VSS
A18	160	71	A21
A16	161	72	A19
A15	162	73	A17
A14	163	74	A13
VDD	164	75	VDD
A10	165	76	A12
A8	166	77	A11
A6	167	78	A9
VSS	168	79	VSS
A4	169	80	A7
A2	170	81	A5
A1	171	82	A3
BURSTMODE	172	83	A0
VCC	173	84	VCC
VALIDIN	174	85	TCLR
TWE	175	86	MATCH
STANDBY	176	87	TG
DIRTYOUT	177	88	DIRTYIN
VSS	178	89	VSS

PIN DESCRIPTIONS

Pin Locations	Symbol	Type	Description
66, 67, 68, 69, 71, 72, 73, 74, 76, 77, 78, 80, 81, 82, 83, 155, 156, 157, 158, 160, 161, 162, 163, 165, 166, 167, 169, 170, 171	A0 – A28	Input	Address Inputs – (MSB:0, LSB:28).
62	ADDR0	Input	Least significant address bit when asynchronous Data RAMs are used.
151	ADDR1	Input	Next to least significant address bit when asynchronous Data RAMs are used.
64, 65	ADS0, ADS1	Input	Data RAM Address Strobe – For MPC2105C use ADS0 only. For MPC2106C use ADS0, ADS1..
149	ALE	Input	Data RAM Address Latch Enable – Use for asynchronous Data RAM only.
172	BURSTMODE	Input	Burstmode. 0 = Linear, 1 = Interleaved.
59, 60	CG0, CG1	Input	Data RAM Output Enables. – For MPC2105C use CG0 only. For MPC2106C use CG0, CG1.
30, 56, 115, 144, 146	CLK0 – CLK4	Input	Clock Inputs – CLK2 is for Tag RAM, CLK0, 1, 3, and 4 are for Data RAMs only. For MPC2106C use all the clocks. For MPC2105C use CLK0 – CLK2 only.
153, 154	CNTEN0, CNTEN1	Input	Data RAM Count Enables – For MPC2105C use CNTEN0 only. For MPC2106C use CNTEN0, CNTEN1.
98, 104, 110, 118, 126, 132, 138, 148	CWE0 – CWE7	Input	Data RAM Write Enables – (MSB:0, LSB:7).
4, 5, 6, 7, 10, 11, 12, 14, 16, 17, 19, 20, 22, 24, 25, 26, 27, 93, 94, 95, 96, 99, 100, 101, 103, 105, 106, 108, 109, 111, 113, 117	DH0 – DH31	I/O	High Data Bus – (MSB:0, LSB:31).
88	DIRTYIN	Input	Dirty input bit.
177	DIRTYOUT	Output	Dirty output bit.
32, 33, 34, 37, 38, 39, 40, 43, 44, 45, 47, 49, 50, 52, 53, 54, 119, 120, 122, 123, 124, 127, 128, 129, 131, 133, 134, 136, 137, 139, 141, 142	DL0 – DL31	I/O	Low Data Bus – (MSB:0, LSB:31).
9, 15, 21, 28, 35, 42, 48, 58	DP0 – DP7	I/O	Data Parity Bits – (MSB:0, LSB:7)
86	MATCH	Output	Tag RAM active high match indication.
2	PD0/IDSCLK	Input	Presence detect bit 0/EEPROM serial clock. (EEPROM option only).
91	PD1/IDSDATA	I/O	Presence detect bit 1/EEPROM serial data. (EEPROM option only).
3, 92	PD2, PD3	Output	Presence detect bits.
63, 152	RESERVED		Reserved pin.
176	STANDBY	Input	Standby pin. Reduces standby power consumption.
85	TCLR	Input	Tag RAM clear.
87	TG	Input	Tag RAM output enable.
175	TWE	Input	Tag RAM write enable.
174	VALIDIN	Input	Tag RAM valid bit.
18, 36, 84, 107, 125, 173	VCC	Input	+ 5 V power supply. Must be connected.
8, 23, 51, 61, 75, 97, 112, 140, 150, 164	VDD	Input	+ 3.3 V power supply. Must be connected.
1, 13, 29, 31, 41, 46, 55, 57, 70, 79, 89, 90, 102, 114, 116, 121, 130, 135, 143, 145, 147, 159, 168, 178	VSS	Input	Ground.

DATA RAM MCM69F618C SYNCHRONOUS TRUTH TABLE (See Notes 1, 2, and 3)

STANDBY	ADSx	CNTENx	CWEx	CLKx	Address Used	Operation
H	L	X	X	L-H	N/A	Deselected
L	L	X	L	L-H	External Address	Write Cycle, Begin Burst
L	L	X	H	L-H	External Address	Read Cycle, Begin Burst
X	H	L	L	L-H	Next Address	Write Cycle, Continue Burst
X	H	L	H	L-H	Next Address	Read Cycle, Continue Burst
X	H	H	L	L-H	Current Address	Write Cycle, Suspend Burst
X	H	H	H	L-H	Current Address	Read Cycle, Suspend Burst

NOTES:

1. X means don't care.
2. All inputs except CG must meet set-up and hold times for the low-to-high transition of clock (CLK0 – CLK4).
3. Wait states are inserted by suspending burst.

ASYNCHRONOUS TRUTH TABLE (See Notes 1 and 2)

Operation	CG	I/O Status
Read	L	Data Out (DQ0 – DQ8)
Read	H	High-Z
Write	X	High-Z — Data In
Deselected	X	High-Z

NOTES:

1. X means don't care.
2. For a write operation following a read operation, \overline{CG} must be high before the input data required set-up time and held high through the input data hold time.

ABSOLUTE MAXIMUM RATINGS (Voltages Referenced to $V_{SS} = 0$ V)

Rating	Symbol	Value	Unit
Power Supply Voltage	V_{CC}	- 0.5 to + 7.0	V
Voltage Relative to V_{SS}	V_{in}, V_{out}	- 0.5 to $V_{CC} + 0.5$	V
Output Current (per I/O)	Data RAM Tag I_{out}	± 30 ± 20	mA
Power Dissipation	MPC2105C MPC2106C P_D	4.6 9.2	W
Temperature Under Bias	T_{bias}	- 10 to + 85	°C
Operating Temperature	T_A	0 to +70	°C
Storage Temperature	T_{stg}	- 55 to + 125	°C

NOTE: Permanent device damage may occur if ABSOLUTE MAXIMUM RATINGS are exceeded. Functional operation should be restricted to RECOMMENDED OPERATING CONDITIONS. Exposure to higher than recommended voltages for extended periods of time could affect device reliability.

This device contains circuitry to protect the inputs against damage due to high static voltages or electric fields; however, it is advised that normal precautions be taken to avoid application of any voltage higher than maximum rated voltages to this high-impedance circuit.

This BiCMOS memory circuit has been designed to meet the dc and ac specifications shown in the tables, after thermal equilibrium has been established.

This device contains circuitry that will ensure the output devices are in High-Z at power up.

DC OPERATING CONDITIONS AND CHARACTERISTICS

($V_{CC} = 5.0\text{ V} \pm 5\%$, $V_{DD} = 3.3\text{ V} \pm 10\%$, $T_A = 0\text{ to } +70^\circ\text{C}$, Unless Otherwise Noted)

RECOMMENDED OPERATING CONDITIONS (Voltages Referenced to $V_{SS} = 0\text{ V}$)

Parameter	Symbol	Min	Max	Unit
Supply Voltage (Operating Voltage Range)	V_{CC}	4.75	5.25	V
	V_{DD}	3.00	3.60	V
Input High Voltage	V_{IH}	2.2	$V_{DD} + 0.3^{**}$	V
Input Low Voltage	V_{IL}	-0.5^*	0.8	V

* $V_{IL}(\text{min}) = -0.5\text{ V dc}$; $V_{IL}(\text{min}) = -2.0\text{ V ac}$ (pulse width $\leq 20\text{ ns}$) for $I \leq 20.0\text{ mA}$.

** $V_{IH}(\text{max}) = V_{DD} + 0.3\text{ V dc}$; $V_{IH}(\text{max}) = V_{DD} + 2.0\text{ V ac}$ (pulse width $\leq 20\text{ ns}$) for $I \leq 20.0\text{ mA}$.

DC CHARACTERISTICS

Parameter	Symbol	Min	Max	Unit
Input Leakage Current (All Inputs, $V_{IH} = 0\text{ to }V_{DD}$)	$I_{lkg(I)}$	—	± 1.0 ± 5.0	μA
Output Leakage Current ($CG = V_{IH}$, $V_{out} = 0\text{ to }V_{DD}$)	$I_{lkg(O)}$	—	± 1.0 ± 5.0	μA
TTL Output Low Voltage ($I_{OL} = +8.0\text{ mA}$)	V_{OL}	—	0.4	V
TTL Output High Voltage ($I_{OH} = -4.0\text{ mA}$)	V_{OH}	2.4	—	V

POWER SUPPLY CURRENTS

Parameter	Symbol	Max	Unit
AC Supply Current ($CG = V_{IH}$, $E = V_{IL}$, $I_{out} = 0\text{ mA}$, All Inputs = V_{IL} and V_{IH} , $V_{IL} = 0.0\text{ V}$ and $V_{IH} \geq 3.0\text{ V}$, Cycle Time $\geq 20\text{ ns}$)	MPC2105C MPC2106C	I_{DDA}	900 1800
	MPC2105C MPC2106C	I_{CCA}	320 640
AC Standby Current ($E = V_{IH}$, $I_{out} = 0\text{ mA}$, All Inputs = V_{IL} or V_{IH} , $V_{IL} = 0.0\text{ V}$ and $V_{IH} \geq 3.0\text{ V}$, Cycle Time $\geq 20\text{ ns}$)	MPC2105C MPC2106C	$I_{SB1}(V_{DD})$	440 880
	MPC2105C MPC2106C	$I_{SB1}(V_{CC})$	320 640

CAPACITANCE ($f = 1.0\text{ MHz}$, $dV = 3.0\text{ V}$, $T_A = 25^\circ\text{C}$, Periodically Sampled Rather Than 100% Tested)

Parameter	Symbol	Typ	Max	Unit
Input Capacitance (A13 – A28) (Data RAM Control Pins) (CLK0 – CLK4) (Tag Control Pins)	C_{in}	—	15	μF
		16	24	
		8	12	
		—	5	
Tag Output Capacitance (MATCH, DIRTYOUT)	C_{out}	—	10	μF
Data RAM Input/Output Capacitance (DH0 – DH31, DL0 – DL31)	$C_{I/O}$	7	9	μF
Tag Input/Output Capacitance (A0 – A11)	$C_{I/O}$	—	10	μF

DATA RAMs AC OPERATING CONDITIONS AND CHARACTERISTICS

(V_{CC} = 5.0 V ± 5%, V_{DD} = 3.3 V ± 10% T_A = 0 to + 70°C, Unless Otherwise Noted)

Input Timing Measurement Reference Level 1.5 V
 Input Pulse Levels 0 to 3.0 V
 Input Rise/Fall Time 3 ns

Output Timing Reference Level 1.5 V
 Output Load See Figure 1 Unless Otherwise Noted

SYNCHRONOUS DATA RAMs READ/WRITE CYCLE TIMING (See Notes 1, 2, and 3)

Parameter	Symbol	MPC2105C MPC2106C		Unit	Notes
		Min	Max		
Cycle Time	t _{KHKH}	15	—	ns	
Clock Access Time	t _{KHQV}	—	9	ns	4
Output Enable to Output Valid	t _{GLQV}	—	5	ns	
Clock High to Output Active	t _{KHQX1}	6	—	ns	
Clock High to Output Change	t _{KHQX2}	3	—	ns	
Output Enable to Output Active	t _{GLQX}	0	—	ns	
Output Disable to Q High-Z	t _{GHQZ}	2	6	ns	
Clock High to Q High-Z	t _{KHQZ}	—	6	ns	
Clock High Pulse Width	t _{KHKL}	5	—	ns	
Clock Low Pulse Width	t _{KLKH}	5	—	ns	
Setup Time	Address t _{AVKH}	7.5	—	ns	5, 6
Setup Times:	Address Status t _{SVKH} Data In t _{DVKH} Write t _{WVKH} Address Advance t _{BAVVKH} Chip Enable t _{EVKH}	2.5	—	ns	5
Hold Times:	Address t _{KHAX} Address Status t _{KHTSX} Data In t _{KHDX} Write t _{KHWX} Address Advance t _{KHBAX} Chip Enable t _{KHEX}	0.5	—	ns	5

NOTES:

1. In setup and hold times, W (write) refers to either one or both byte write enables LW and UW.
2. All read and write cycle timings are referenced from CLK or CG.
3. CG is a don't care when UW or LW is sampled low.
4. Maximum access times are guaranteed for all possible PowerPC external bus cycles.
5. This is a synchronous device. All addresses must meet the specified setup and hold times for ALL rising edges of CLK whenever TSP or TSC is low, and the chip is selected. All other synchronous inputs must meet the specified setup and hold times for ALL rising edges of CLK when the chip is enabled. Chip enable must be valid at each rising edge of clock for the device (when TSP or TSC is low) to remain enabled.
6. 5 ns of setup delay is incurred in address buffers.

SYNCHRONOUS DATA RAM READ CYCLE

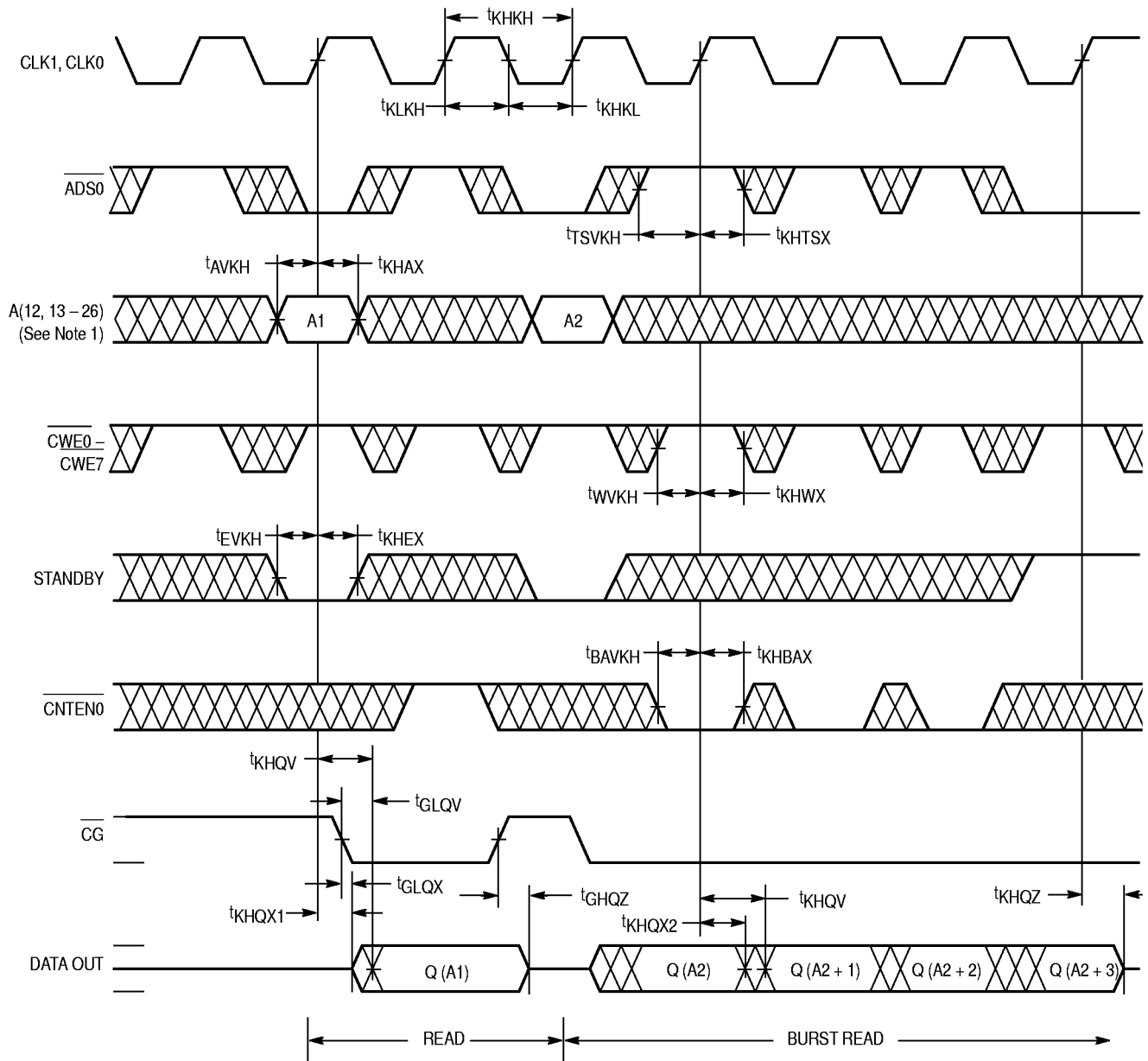

NOTES:

1. Cache addresses used are: 13 – 26 for MPC2105C; and 12 – 26 for MPC2106C.
2. Q1 (A2) represents the first output from the external address A2; Q2 (A2) represents the next output data in the burst sequence with A2 as the base address.

SYNCHRONOUS DATA RAM WRITE CYCLE

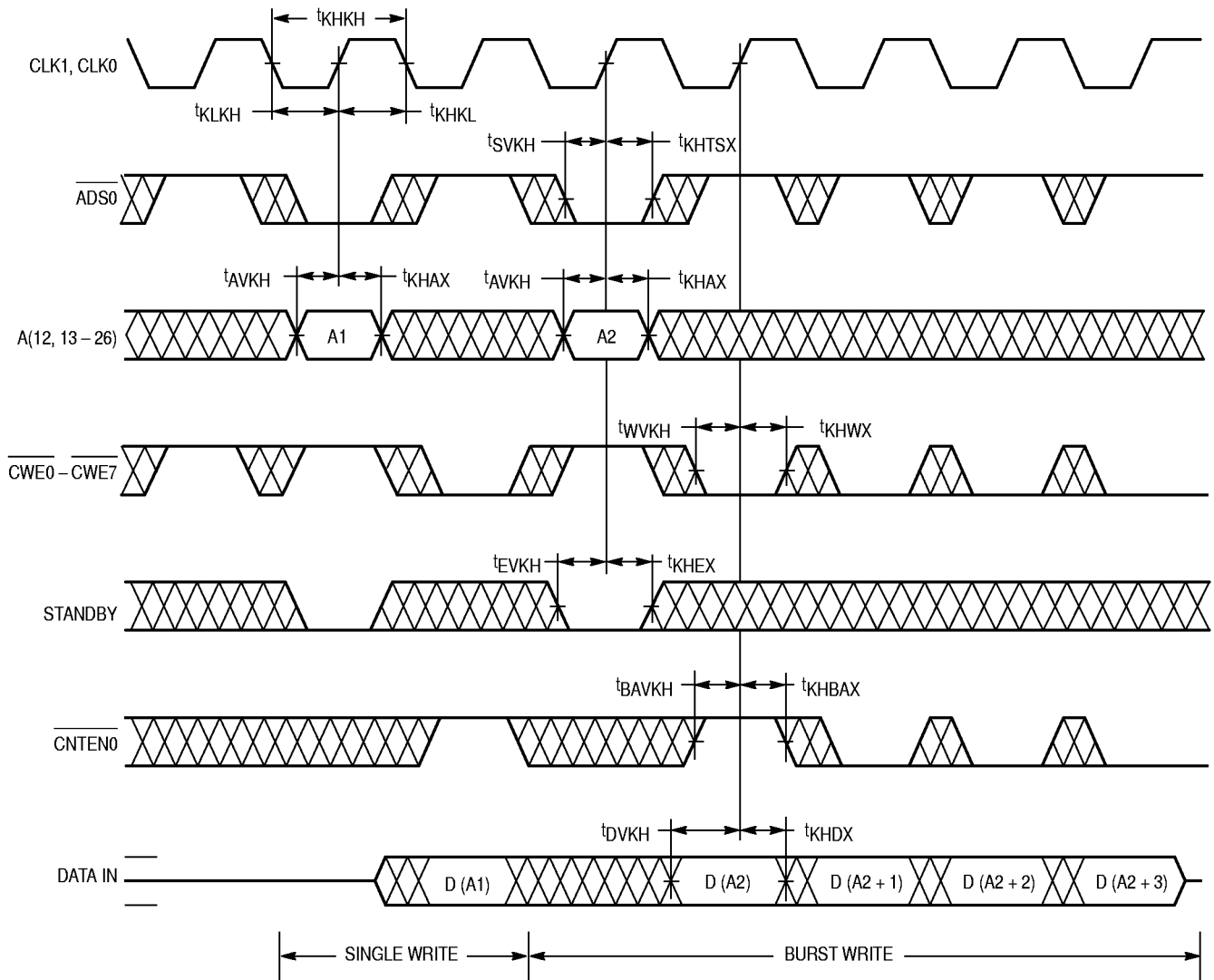

NOTES:

1. Cache addresses used are: 13 – 26 for MPC2105C; and 12 – 26 for MPC2106C.
2. $CG0 = V_{IH}$

TAG RAM

RESET FUNCTION TRUTH TABLE (See Notes 1 and 2)

TCLR	CLK	TWE	TAG0 – TAG11	DIRTYOUT	MATCH	Operation	POWER
L	L – H	H	High-Z	L ⁽³⁾	L ⁽³⁾	Reset Status	Active
L	L – H	L	—	—	—	Not Allowed	—

NOTES:

- H = V_{IH}, L = V_{IL}, X = don't care, — = undefined.
- TG is X for this table.
- These are output states.

READ FUNCTION TRUTH TABLE (See Notes 1, 2, and 3)

TG	TWE	CLK	TAG0 – TAG11	VALIDIN	DIRTYIN	DIRTYOUT	MATCH	Operation
L	H	X	D _{out}	—	—	D _{out}	D _{out}	Read Tag I/O
H	X	X	High-Z	—	—	—	—	Tag I/O Disable

WRITE FUNCTION TRUTH TABLE (See Notes 1 and 2)

TG	TWE	CLK	TAG0 – TAG11	VALIDIN	DIRTYIN	DIRTYOUT	MATCH	Operation
H	L	L – H	D _{in}	—	—	—	L	Write Tag I/O
L	L	L – H	—	—	—	—	—	Not Allowed

NOTES:

- H = V_{IH}, L = V_{IL}, X = don't care, — = undefined.
- This table applies when RESET and PWRDN are high.
- D_{out} in this case is the same as D_{in}. The input data is written through to the outputs during the write operation.

MATCH FUNCTION TRUTH TABLE (See Notes 1 through 4)

TG	TWE	TAG0 – TAG11	VALIDIN ⁽⁴⁾	DIRTYIN ⁽⁴⁾	MATCH	Operation
X	X	—	—	—	D _{out}	Selected
L	H	D _{out}	—	—	L	Read Tag I/O
H	L	D _{in}	D _{in}	D _{in}	L	Write Tag I/O, Status Bits
H	H	TAG _{in}	L	—	L	Invalid Data – Dedicated Status Bits
H	H	TAG _{in}	H	—	H	Match – Dedicated Status Bits

NOTES:

- H = V_{IH}, L = V_{IL}, X = don't care, — = undefined.
- M = high if TAG_{in} equals the memory contents at the address; M = low if TAG_{in} does not equal the contents at that address.
- PWRDN and RESET are high for this table. GS and CLK are X.
- This column represents the stored memory cell data for the given status bit at the selected address.

TAG RAM AC OPERATING CONDITIONS AND CHARACTERISTICS

(V_{CC} = 5.0 V ± 5%, T_A = 0 to + 70°C, Unless Otherwise Noted)

Input Timing Measurement Reference Level 1.5 V
 Input Pulse Levels 0 to 3.0 V
 Input Rise/Fall Time 3 ns

Output Timing Measurement Reference Level 1.5 V
 Output Load Figure 1 Unless Otherwise Noted

TAG RAM READ CYCLE (See Notes 1 through 4)

Parameter	Symbol	Tag RAM		Unit
		Min	Max	
Clock Access Time	t _{KHQV}	—	10	ns
Output Enable to Output Valid	t _{GLQV}	—	8	ns
Output Enable to Output Active	t _{GLQX}	0	—	ns
Output Disable to Q High-Z	t _{GHQZ}	1	6	ns
Status Bit Hold from Address Change	t _{AXSX}	3	—	ns
Address Access Time Status Bits	t _{AVSV}	—	10	ns
Tag Bit Hold from Address Change	t _{AVQX}	3	—	ns
Address Access Time Tag Bits	t _{AVQV}	—	12	ns

NOTES:

1. Setup and hold times, W (write) refers to TWE.
2. A read cycle is defined by TWE high. A write cycle is defined by TWE low.
3. Maximum access times are guaranteed for all possible MC68040 and PowerPC external bus cycles.
4. Tag reads are asynchronous.

TAG RAM WRITE CYCLE (See Notes 1 through 4)

Parameter	Symbol	Tag RAM		Unit
		Min	Max	
Cycle Time	t _{KHKH}	15	—	ns
Clock High Pulse Width	t _{KHKL}	4.5	—	ns
Clock Low Pulse Width	t _{KLKH}	4.5	—	ns
Clock High to Output Active	t _{KHQX}	1.5	—	ns
Setup Times	Address	t _{AVKH}	3	ns
	Write	t _{WVKH}		
Hold Times	Address	t _{KHAX}	1.5	ns
	Write	t _{KHWX}		
Status Output Hold	t _{KHSX}	0	—	ns
Clock High to Status Bits Valid	t _{KHSV}	—	9	ns

NOTES:

1. Setup and hold times, W (write) refers to TWE.
2. A read cycle is defined by TWE high. A write cycle is defined by TWE low.
3. Maximum access times are guaranteed for all possible MC68040 and PowerPC external bus cycles.
4. Tag writes are synchronous.

TAG RAM MATCH CYCLE

Parameter	Symbol	Tag RAM		Unit
		Min	Max	
Clock High Write to MATCH Invalid	t_{KHML}	—	7	ns
Clock High Read to MATCH Valid	t_{KHMV}	—	10	ns
Address Valid to MATCH Valid	t_{AVMV}	—	10	ns
MATCH Valid Hold from Address Change	t_{AXMX}	2	—	ns
TG Low to MATCH Invalid	t_{GLML}	—	7	ns
TG High to MATCH Valid	t_{GHMX}	—	8	ns

TAG RAM RESET (TCLR) CYCLE

Parameter	Symbol	Tag RAM		Unit
		Min	Max	
TCLR Setup Time	t_{STC}	4	—	ns
TCLR Hold Time	t_{HTC}	1	—	ns
Status Bit Reset Time	t_{SRST}	—	60	ns
Status Bit Hold from TCLR Low	t_{SHRS}	2	—	ns
TCLR Low to MATCH Invalid	t_{RSML}	—	10	ns
TCLR High to MATCH Valid	t_{RSMV}	—	100	ns
TCLR Low to TAG High-Z	t_{RSQZ}	—	10	ns
TCLR High to TAG Active	t_{RSQX}	—	100	ns
STANDBY Setup to TCLR Low	t_{PDSR}	30	—	ns
TCLR High to TWE Low	t_{RHWX}	80	—	ns

TIMING LIMITS

The table of timing values shows either a minimum or a maximum limit for each parameter. Input requirements are specified from the external system point of view. Thus, address setup time is shown as a minimum since the system must supply at least that much time. On the other hand, responses from the memory are specified from the device point of view. Thus, the access time is shown as a maximum since the device never provides data later than that time.

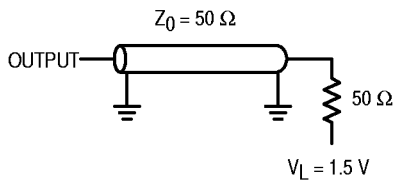
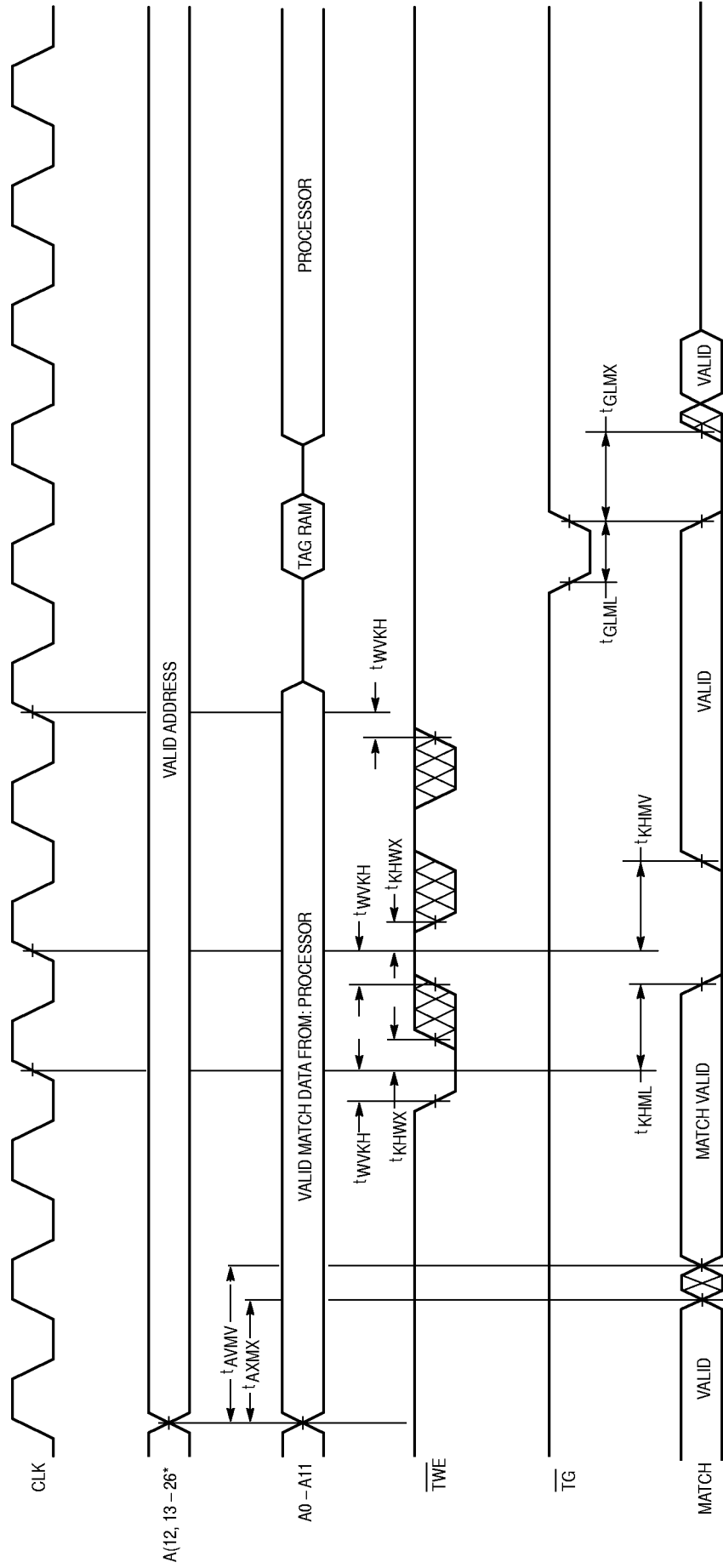

Figure 1. AC Test Load

TAG RAM MATCH CYCLE



* Cache addresses used are: A13 - A26 for MPC2105C, A12 - A26 for MPC2106C.

TAG RAM TCLR FUNCTION

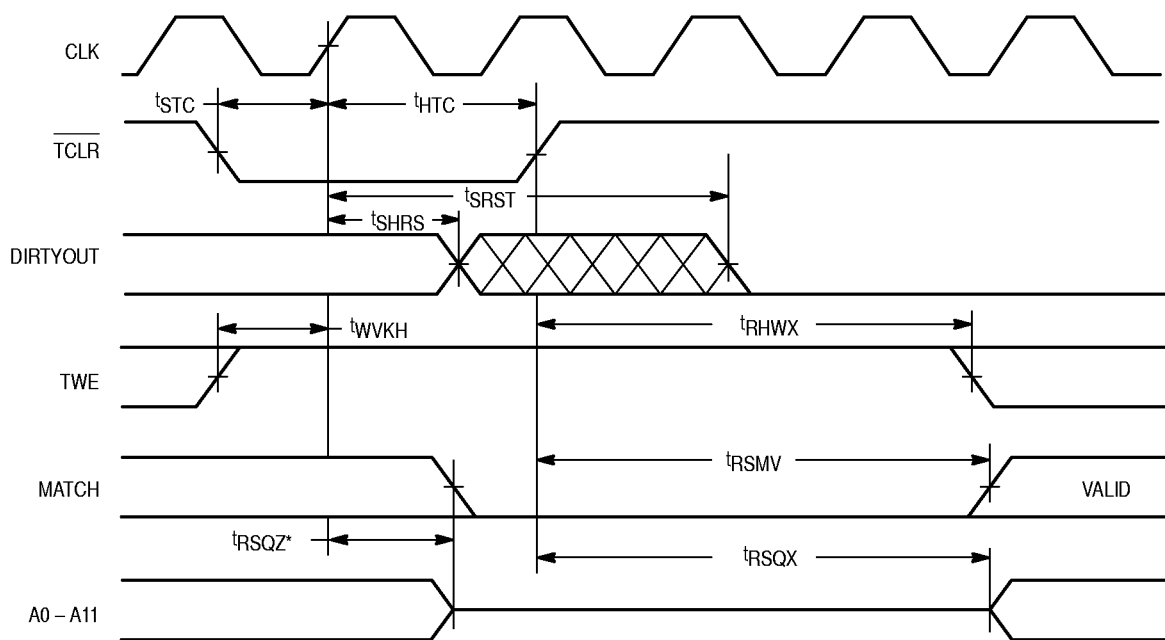

* Transition is measured plus or minus 200 mV from steady state.

ORDERING INFORMATION (Order by Full Part Number)

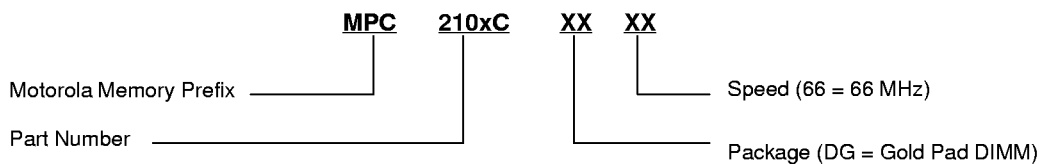

Full Part Numbers — MPC2105CDG66
MPC2106CDG66

MPC2105C = 512KB, synchronous
MPC2106C = 1MB, synchronous

PACKAGE DIMENSIONS

178 LEAD CARD EDGE
MPC2105C
CASE 1132A-01

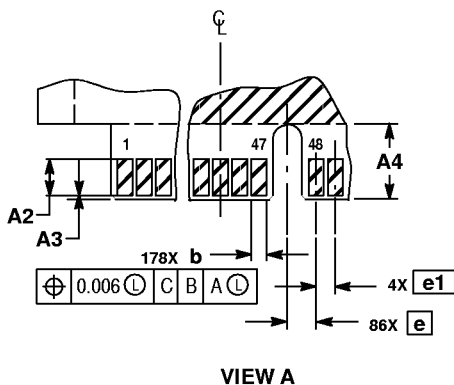
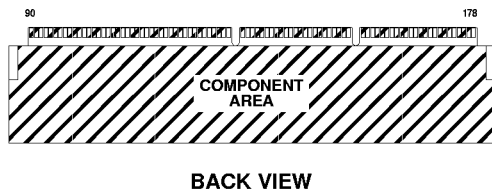
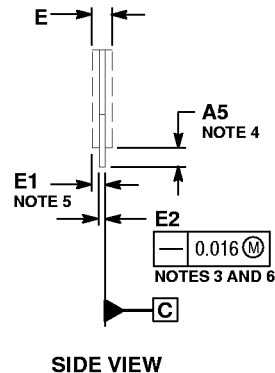
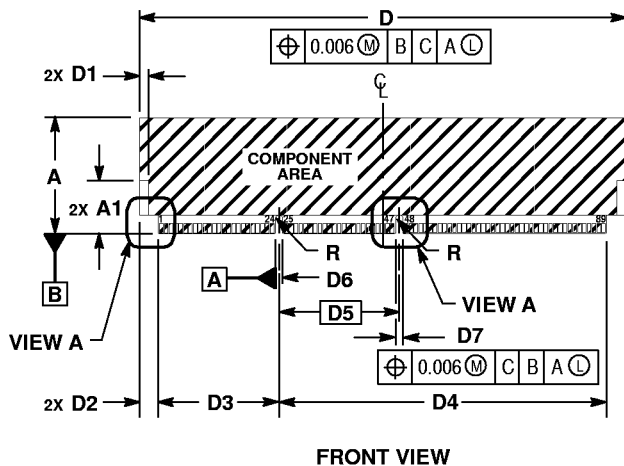

- NOTES:
1. DIMENSIONS AND TOLERANCING PER ASME Y14.5M, 1994.
 2. DIMENSIONS IN INCHES.
 3. CARD THICKNESS APPLIES ACROSS TABS AND INCLUDES PLATING AND/OR METALLIZATION.
 4. DIMENSIONS E AND A5 DEFINE A DOUBLE-SIDED MODULE.
 5. DIMENSION E1 DEFINES OPTIONAL SINGLE-SIDED MODULE.
 6. STRAIGHTNESS CALLOUT APPLIES TO TAB AREA ONLY.

DIM	INCHES	
	MIN	MAX
A	1.190	1.210
A1	0.545	—
A2	0.095	—
A3	—	0.010
A4	0.195	—
A5	0.195	—
b	0.039	0.043
D	5.055	5.065
D1	0.100	—
D2	0.190	—
D3	1.255	1.265
D4	3.405	3.410
D5	1.250 BSC	
D6	0.072	0.076
D7	0.075	0.081
e	0.050 BSC	
e1	0.075 BSC	
E	—	0.210
E1	—	0.140
E2	0.055	0.070

**178 LEAD CARD EDGE
MPC2106C
CASE 1132-01**

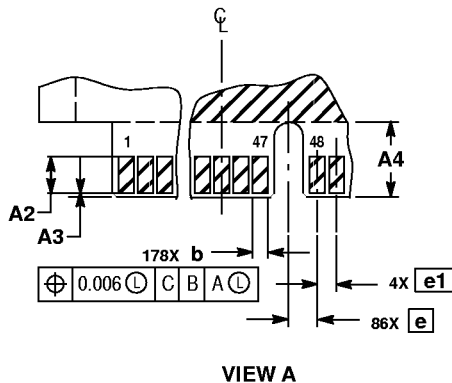
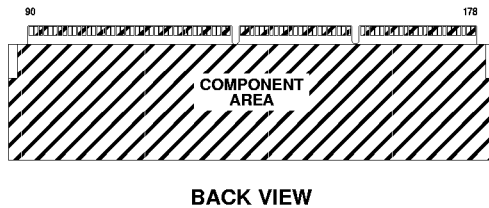
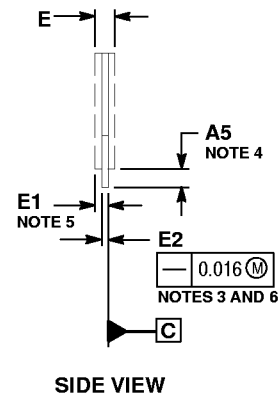
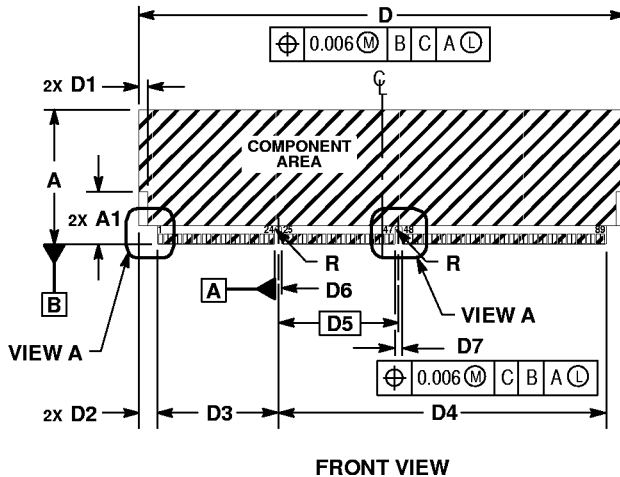

NOTES:

1. DIMENSIONS AND TOLERANCING PER ASME Y14.5M, 1994.
2. DIMENSIONS IN INCHES.
3. CARD THICKNESS APPLIES ACROSS TABS AND INCLUDES PLATING AND/OR METALLIZATION.
4. DIMENSIONS E AND A5 DEFINE A DOUBLE-SIDED MODULE.
5. DIMENSION E1 DEFINES OPTIONAL SINGLE-SIDED MODULE.
6. STRAIGHTNESS CALLOUT APPLIES TO TAB AREA ONLY.

DIM	INCHES	
	MIN	MAX
A	1.390	1.410
A1	0.545	—
A2	0.095	—
A3	—	0.010
A4	0.195	—
A5	0.195	—
b	0.039	0.043
D	5.055	5.065
D1	0.100	—
D2	0.190	—
D3	1.255	1.265
D4	3.405	3.410
D5	1.250	BSC
D6	0.072	0.076
D7	0.075	0.081
e	0.050	BSC
e1	0.075	BSC
E	—	0.210
E1	—	0.140
E2	0.055	0.070

Motorola reserves the right to make changes without further notice to any products herein. Motorola makes no warranty, representation or guarantee regarding the suitability of its products for any particular purpose, nor does Motorola assume any liability arising out of the application or use of any product or circuit, and specifically disclaims any and all liability, including without limitation consequential or incidental damages. "Typical" parameters which may be provided in Motorola data sheets and/or specifications can and do vary in different applications and actual performance may vary over time. All operating parameters, including "Typicals" must be validated for each customer application by customer's technical experts. Motorola does not convey any license under its patent rights nor the rights of others. Motorola products are not designed, intended, or authorized for use as components in systems intended for surgical implant into the body, or other applications intended to support or sustain life, or for any other application in which the failure of the Motorola product could create a situation where personal injury or death may occur. Should Buyer purchase or use Motorola products for any such unintended or unauthorized application, Buyer shall indemnify and hold Motorola and its officers, employees, subsidiaries, affiliates, and distributors harmless against all claims, costs, damages, and expenses, and reasonable attorney fees arising out of, directly or indirectly, any claim of personal injury or death associated with such unintended or unauthorized use, even if such claim alleges that Motorola was negligent regarding the design or manufacture of the part. Motorola and  are registered trademarks of Motorola, Inc. Motorola, Inc. is an Equal Opportunity/Affirmative Action Employer.

Mfax is a trademark of Motorola, Inc.

How to reach us:

USA/EUROPE/ Locations Not Listed: Motorola Literature Distribution;
P.O. Box 5405, Denver, Colorado, 80217. 1-303-675-2140 or 1-800-441-2447

Mfax™: RMFAX0@email.sps.mot.com — TOUCHTONE 1-602-244-6609
Motorola Fax Back System — US & Canada ONLY 1-800-774-1848
— http://sps.motorola.com/mfax/

HOME PAGE: <http://motorola.com/sps/>

JAPAN: Nippon Motorola Ltd.; SPD, Strategic Planning Office; 4-32-1,
Nishi-Gotanda; Shinagawa-ku, Tokyo 141, Japan. 81-3-5487-8488

ASIA/PACIFIC: Motorola Semiconductors H.K. Ltd.; 8B Tai Ping Industrial Park,
51 Ting Kok Road, Tai Po, N.T., Hong Kong. 852-26629298

CUSTOMER FOCUS CENTER: 1-800-521-6274

