

FEATURES

- Integrated Monolithic Upconverter
- High Linearity
- Single Supply Voltage Operation
- High Reliability

DESCRIPTION

The FMM5116X is a double, single balanced diode mixer upconverter designed for applications in the 20 to 32GHz frequency range. The device consists of a low noise mixer, LO amplifier, and LO frequency doubler. This upconverter is uniquely suited for point-to-point radios, local multi-point distribution systems (LMDS) and satellite communications, as it offers a high dynamic range over a large bandwidth.

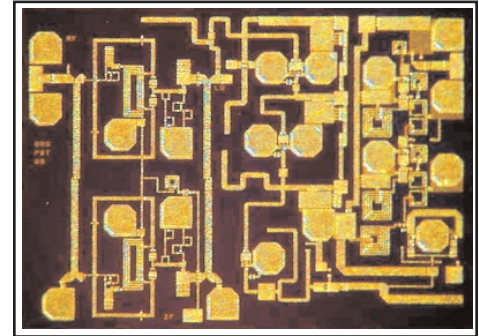

ABSOLUTE MAXIMUM RATINGS (Ambient Temperature Ta=25°C)

Parameter	Symbol	Rating	Unit
DC Supply Voltage	V _{DD1,2}	8	V
Input Power	P _{inIF}	20	dBm
Input Power	P _{inLO}	10	dBm
Storage Temperature	T _{stg}	-65 to +175	°C

RECOMMENDED OPERATING CONDITIONS

Item	Symbol	Recommend			Unit
		Min.	Typ.	Max.	
DC Supply Voltage	V _{DD1,2}		5.0		V
Input LO Power Level	P _{inLO}	0.0	3.0	5.0	dBm
Operating Backside Temperature	T _{bs}	-45	25	110	°C

Note 1: This product should be hermetically packaged.

ELECTRICAL CHARACTERISTICS (Ambient Temperature Ta=25°C)

Item	Symbol	Conditions	Limits			Unit
			Min.	Typ.	Max.	
RF Frequency Range	f _{RF}	V _{DD1,2} =5V, V _{GG} =0V, P _{LO} =3dBm, P _{IF} =0dBm	20	-	32	GHz
LO Frequency Range	f _{LO}		9.5	-	16.5	GHz
IF Frequency Range (Note 2)	f _{IF}		0.1	-	3	GHz
Conversion Gain	G		-18	-10	-	dB
Conversion Gain Flatness (fixed f _{IF} , swept f _{LO}) (f _{IF} =1.0GHz)	ΔG		-	3	-	dB
Conversion Gain Flatness (fixed f _{LO} , swept f _{IF}) (f _{LO} =13.5GHz)	ΔG		-	2	-	dB
Return Loss (RF/LO)	RL _{RF} , RL _{LO}		-	12	-	dB
Return Loss (IF)	RL _{IF}		-	4	-	dB
Input P1dB at IF Port	P1dB _{IFIN}		-	15	-	dBm
3rd Order Input Intercept Point	IIP3		-	23	-	dBm
DC Current Consumption	I _{DC}		-	100	150	mA
RF Current Consumption	I _{RF}		-	140	200	mA

Note 1: The electrical characteristics are measured on a sample basis at 10pcs./wafer. Criteria: (accept/reject)=(0/1)

Note 2: The IF frequency range is dependent on the selected LO and RF frequency.

FMM5116X

20-32GHz Upconverter MMIC

CONVERSION GAIN vs. FREQUENCY

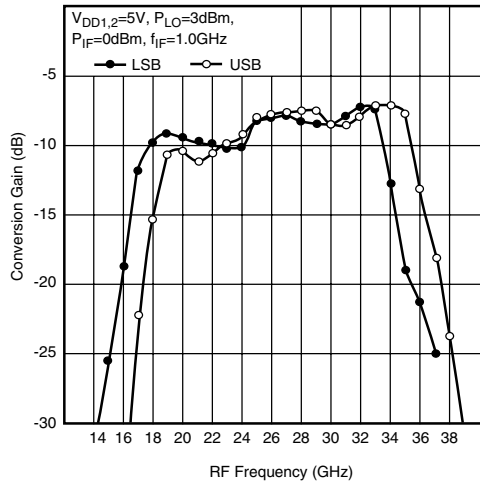

IM3 vs. FREQUENCY

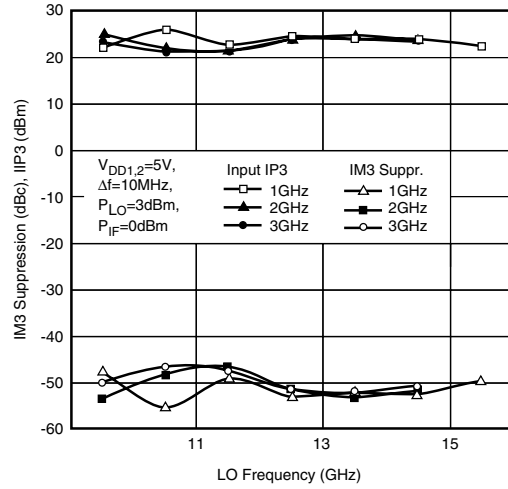

CONVERSION GAIN vs. FREQUENCY

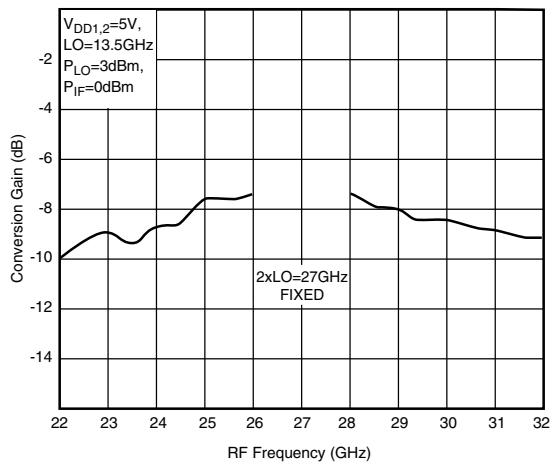

2xLO OUTPUT POWER vs. FREQUENCY

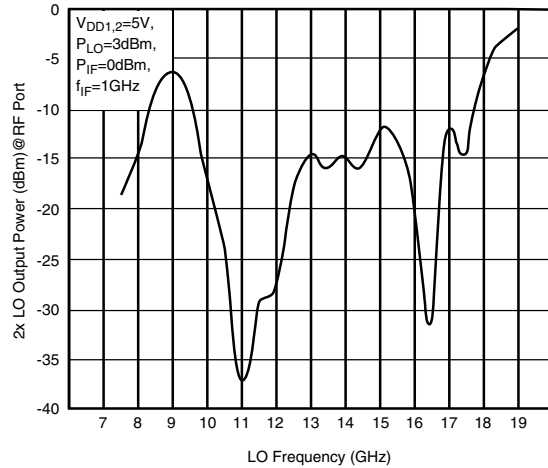

RF RETURN LOSS vs. FREQUENCY

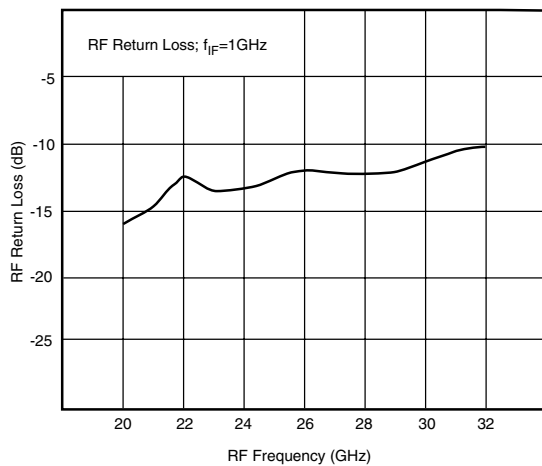

IF RETURN LOSS vs. FREQUENCY

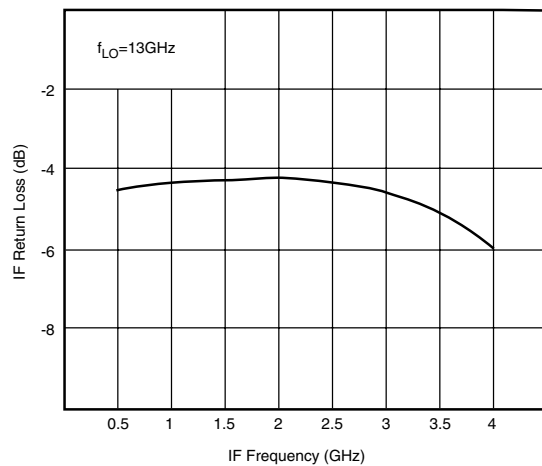

BONDING DIAGRAM

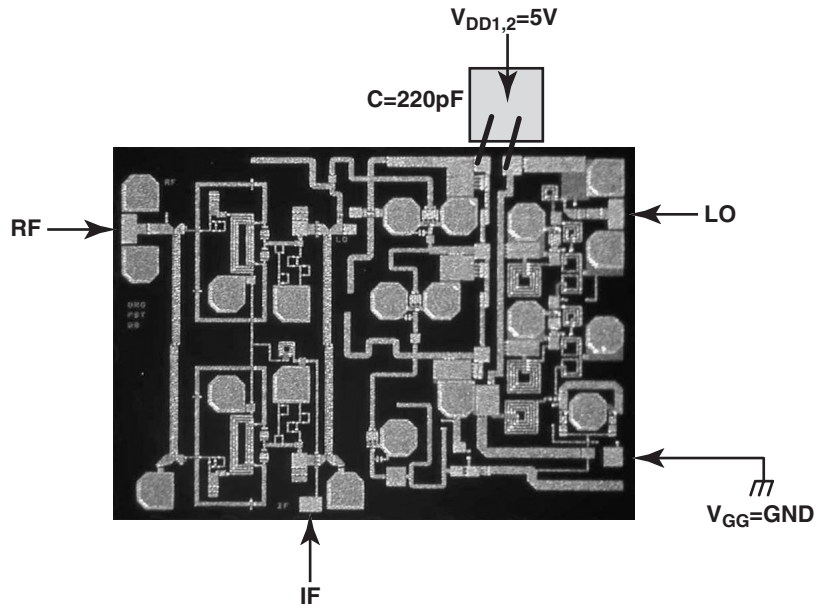

FUNCTIONAL DIAGRAM

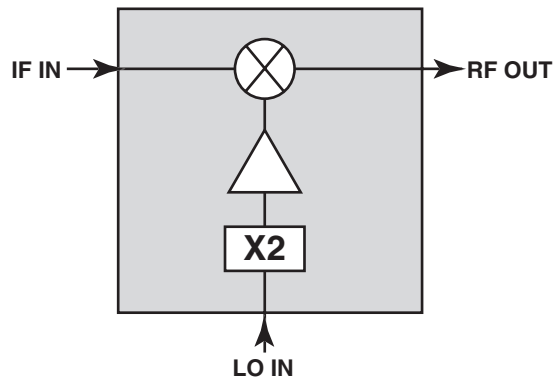

FMM5116X

20-32GHz Upconverter MMIC

