

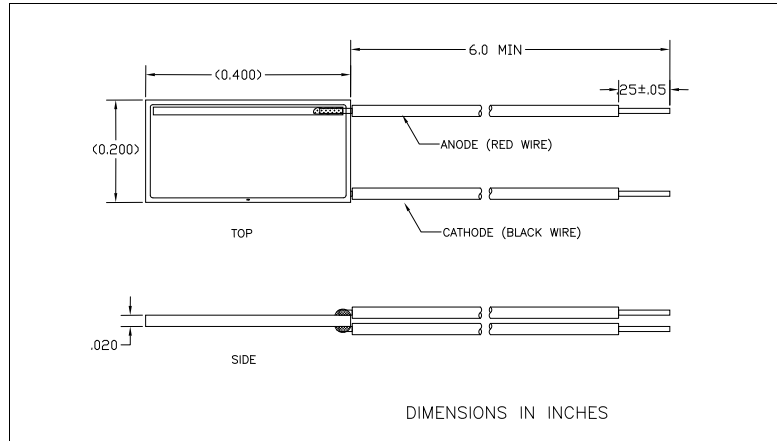

Solderable Planar Photodiode
PRELIMINARY **SLSD-71N300**

Precision – Control – Results



DESCRIPTION

The SLSD-71N300 is a solderable planar photodiode featuring low cost, high reliability, and linear short circuit current over a wide range of illumination. These devices are widely used for light sensing and power generation because of their stability and high efficiency. They are particularly suited to power conversion applications due to their low internal impedance, relatively high shunt impedance, and stability. The photodiodes have a protective coating that protects them from humidity effects. These devices also provide a reliable and inexpensive detector for instrumentation and light beam sensing applications.

FEATURES

- Visible to IR spectral irradiance range
- High reliability
- Oxide passivation
- Linear short circuit current
- Low capacitance, high speed
- Si surface protected with the thin film coating

RELIABILITY

This Luna high-reliability device is in principle able to meet military test requirements (Mil-STD-750, Mil-STD-883) after proper screening and group test. Contact Luna for recommendations on specific test conditions and procedures.

APPLICATIONS

- Light sensing
- Power generation

ABSOLUTE MAXIMUM RATINGS

SYMBOL	MIN		MAX	UNITS	
Operating Temperature	-40	to	+105	°C	Non-condensing
Storage Temperature	-40	to	+105	°C	-
Soldering Temperature	-	to	+240	°C	-
Wavelength Range	400	To	1100	nm	-

Information in this technical datasheet is believed to be correct and reliable. However, no responsibility is assumed for possible inaccuracies or omission. Specifications are subject to change without notice.

REV 01-04-16
 © 2016 Luna Optoelectronics. All rights reserved.



Solderable Planar Photodiode
PRELIMINARY **SLSD-71N300**

Precision – Control – Results

OPTO-ELECTRICAL PARAMETERS

T_a = 23°C UNLESS NOTED OTHERWISE

PARAMETER	TEST CONDITIONS	MIN	TYP	MAX	UNITS
Short Circuit Current	V _R = 0V, Ee= 25mW/cm ² **	1.3	2.1	-	mA
Open Circuit Voltage	Ee = 25mW/cm ² **	-	0.40	-	V
Dark Current	V _R = 5V, Ee=0, T=25°C	-	-	1.7	μA
Junction Capacitance	V _R = 0V, Ee = 0, f=1MHz	-	1.0	-	nF
Spectral Sensitivity	λ-940nm, Flood illumination*	-	0.55	-	A/W
Breakdown Voltage	I _R = 100μA	20	-	-	V
Maximum Sensitivity Wavelength	-	-	930	-	nm
Acceptance Half Angle	(off center line)	-	60	-	deg

* Minimum 50% of active area illuminated

**Light source @ 2854°K

TYPICAL PERFORMANCE

DIRECTIONAL SENSIVITY

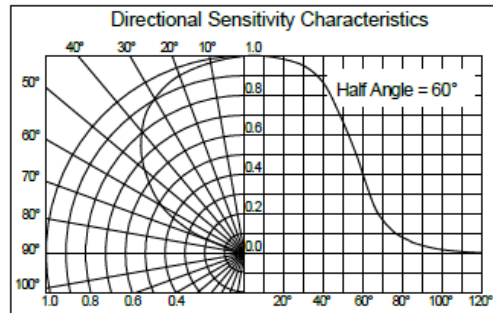

Information in this technical datasheet is believed to be correct and reliable. However, no responsibility is assumed for possible inaccuracies or omission. Specifications are subject to change without notice.

REV 01-04-16

© 2016 Luna Optoelectronics. All rights reserved.