



Low-Power Mobile VGA EMI Reduction IC

Features

- FCC approved method of EMI attenuation
- Generates a low EMI spread spectrum and a non-spread reference signal of the input clock frequency
- Optimized for frequency range from
 - P1817A: 20 to 32 MHz operation
 - P1817B: 10 to 20 MHz operation
- Internal loop filter minimizes external components and board space
- Two selectable spread ranges
- Low inherent cycle-to-cycle jitter
- 3.3 and 5.0 V operating voltage
- CMOS/TTL compatible inputs and outputs
- **Ultra low power** CMOS design:
 - 3.17mA @3.3V, 10 MHz 6.20mA @5.0V, 10 MHz
 - 4.28mA @3.3V, 14 MHz 7.50mA @5.0V, 14 MHz
 - 5.50mA @3.3V, 20 MHz 9.50mA @5.0V, 20 MHz
- Supports notebook VGA and other LCD timing controller applications
- SSON pin for Spread Spectrum On/Off and Standby Mode controls
- Available in 8-pin SOIC and TSSOP

Block Diagram

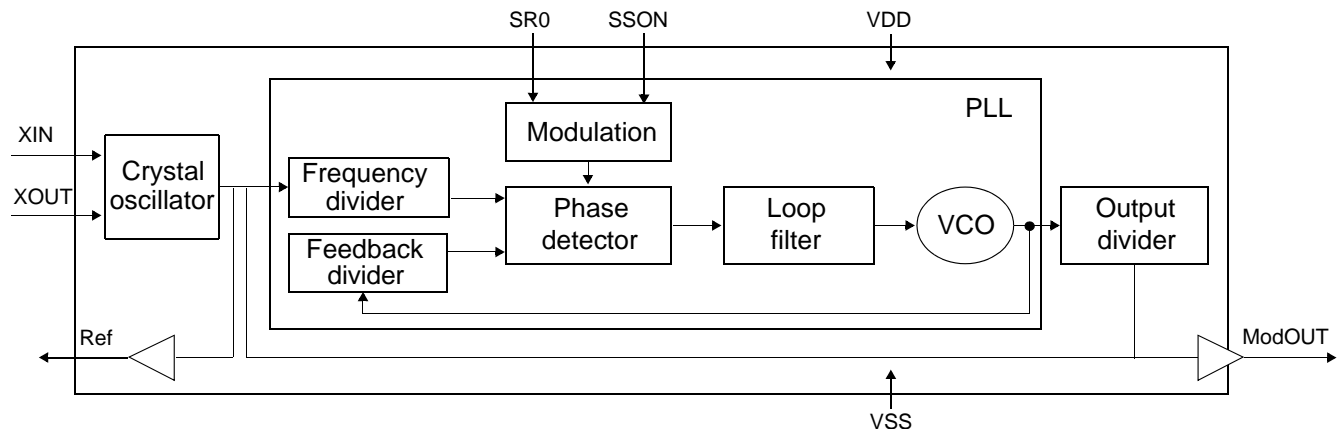

Product Description

The P1817 is a versatile spread spectrum frequency modulator designed specifically for a wide range of clock frequencies. It reduces electromagnetic interference (EMI) at the clock source allowing system-wide reduction of EMI of downstream clock and data dependent signals. It allows significant system cost savings by reducing the number of circuit board layers and shielding traditionally required to pass EMI regulations.

The P1817 modulates the output of a single PLL in order to spread the bandwidth of a synthesized clock, thereby decreasing the peak amplitudes of its harmonics. This results in significantly lower system EMI compared to the typical narrow band signal produced by oscillators and most clock generators. Lowering EMI by increasing a signal's bandwidth is called spread spectrum clock generation.

The P1817 uses the most efficient and optimized modulation profile approved by the FCC and is implemented by using a proprietary all-digital method.

Applications

The P1817 is targeted toward the notebook VGA chip and other displays using an LVDS interface, PC peripheral devices, and embedded systems.

Pin Diagram

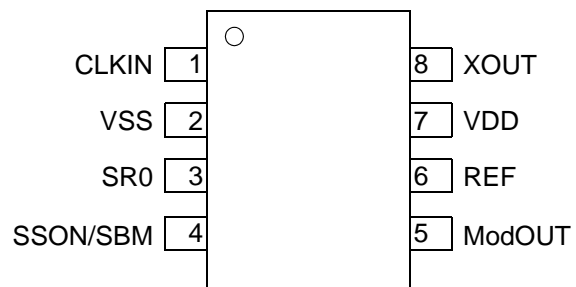



Standby Mode Selection

| CLKIN | SSON/SBM | Spread Spectrum | ModOUT | PLL | Mode |
|----------|----------|-----------------|-----------|--------------|--------------|
| Disabled | 0 | N/A | Disabled | Disabled | Standby |
| Disabled | 1 | N/A | Disabled | Free running | Free running |
| Enabled | 0 | Off | Reference | Disabled | Buffer out |
| Enabled | 1 | On | Normal | Normal | Normal |

Spread Range Selection

| SR0 | Spreading range | Modulation rate |
|-----|-----------------|-----------------------------------|
| 0 | $\pm 1.50\%$ | $(F_{in}/10) * 20.83 \text{ KHz}$ |
| 1 | $\pm 1.25\%$ | $(F_{in}/10) * 20.83 \text{ KHz}$ |

Pin Description

| Pin # | Name | Type | Description |
|-------|----------|------|--|
| 1 | CLKIN | I | Connect to externally generated clock signal. To put the part into standby mode, disable the input clock signal to this pin and pull SSON/SBM (pin 4) low. (See Standby Mode Selection.) |
| 2 | VSS | P | Ground connection. Connect to system ground. |
| 3 | SR0 | I | Digital logic input used to select Spreading Range. (See Spread Spectrum Selection.) This pin has an internal pull-up resistor. |
| 4 | SSON/SBM | I | Spread Spectrum On/Off and Standby Mode control. (See Standby Mode Selection.) This pin has an internal pull-up resistor. |
| 5 | ModOUT | O | Spread Spectrum clock output or Reference output. (See Standby Mode Selection.) |
| 6 | REF | O | Reference output. |
| 7 | VDD | P | Connect to +3.3 V or 5.0 V. |
| 8 | XOUT | I | Connect to crystal. No connect if externally generated clock signal is used. |



Schematic for Notebook VGA Application

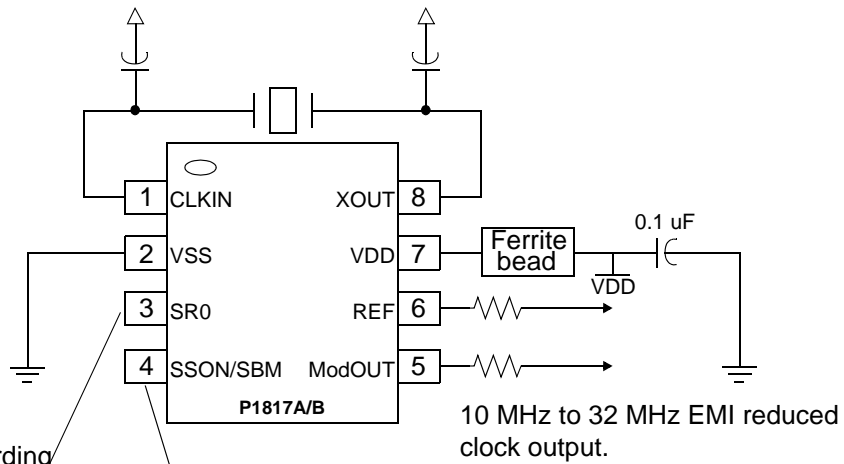

Tie pin 3 SR0 high/low according to spread range desired. External resistors are not needed to pull these pins high.

Pin 4 SSON should be left unconnected to turn on Spread Spectrum.

Pull this pin low to turn Spread Spectrum off and enable Standby Mode.¹

¹ To set the P1817 to standby mode, disable the input clock (pin 1 CLKIN), and pull pin 4 SSON/SBM low.



Absolute Maximum Ratings

| Symbol | Parameter | Rating | Units |
|------------------|--|--------------|-------|
| V_{DD}, V_{IN} | Voltage on any pin with respect to GND | -0.5 to +7.0 | V |
| T_{STG} | Storage temperature | -65 to +125 | °C |
| T_A | Operating temperature | 0 to +70 | °C |

DC Electrical Characteristics

| Symbol | Parameter | Min | Typ | Max | Units | |
|-----------|--|---|---------------------|-------------------|---------------------|----|
| V_{IL} | Input low voltage | GND - 0.3 | – | 0.8 | V | |
| V_{IH} | Input high voltage | 2.0 | – | $V_{DD} + 0.3$ | V | |
| I_{IL} | Input low current (pull-up resistor on inputs SR0 and SSON/SBM) | – | – | -35 | μA | |
| I_{IH} | Input high current | – | – | 35 | μA | |
| I_{XOL} | XOUT output low current | at 0.4 V, $V_{DD} = 3.3V$ | – | 3 | – | mA |
| | | at 0.4 V, $V_{DD} = 5.0 V$ | – | 20 | – | mA |
| I_{XOH} | XOUT output high current | at 2.5 V, $V_{DD} = 3.3 V$ | – | 3 | – | mA |
| | | at 4.5 V, $V_{DD} = 5.0 V$ | – | 20 | – | mA |
| V_{OL} | Output low voltage | $V_{DD} = 3.3 V, I_{OL} = 20 mA$ | – | – | 0.4 | V |
| | | $V_{DD} = 5.0 V, I_{OL} = 20 mA$ | – | – | – | V |
| V_{OH} | Output high voltage | $V_{DD} = 3.3 V, I_{OL} = 20 mA$ | 2.5 | – | – | V |
| | | $V_{DD} = 5.0 V, I_{OL} = 20 mA$ | 4.5 | – | – | V |
| I_{DD} | Static supply current standby mode | – | 0.6 | – | mA | |
| I_{CC} | Dynamic supply current | Normal mode: 3.3 V and 10 pF loading | f_{IN-min} 3.2 | f_{IN-typ} – | f_{IN-max} 7.0 | mA |
| | | 5.0 V and 10 pF loading | 6.2 | – | 13.6 | mA |
| | | | | | | |
| V_{DD} | Operating voltage | 2.7 | 3.3 | 5.5 | V | |
| t_{ON} | Power-up time (first locked cycle after power up) | – | 0.18 | – | mS | |
| Z_{OUT} | Clock output impedance | – | 50 | – | Ω | |

AC Electrical Characteristics

| Symbol | Parameter | Min | Typ | Max | Units | |
|------------|-------------------------|-----------------------------|-----|------|-------|----|
| f_{IN} | Input frequency | 10 | – | 32 | MHz | |
| f_{OUT} | Output frequency | 10 | – | 32 | MHz | |
| t_{LH}^1 | Output rise time | Measured at 0.8 V to 2.0 V | 0.7 | 0.9 | 1.1 | ns |
| | | Measured at 1.2 V to 3.75 V | – | 0.75 | – | ns |
| t_{HL}^1 | Output fall time | Measured at 2.0 V to 0.8 V | 0.6 | 0.8 | 1.0 | ns |
| | | Measured at 1.2 V to 3.75 V | – | 0.75 | – | ns |
| t_{JC} | Jitter (cycle to cycle) | – | – | 360 | ps | |
| t_D | Output duty cycle | 45 | 50 | 55 | % | |

¹ t_{LH} and t_{HL} are measured into a capacitive load of 15 pF.



Mechanical Package Outline (8-Pin SOIC)

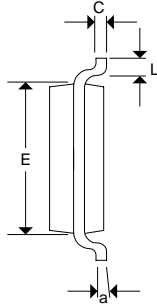
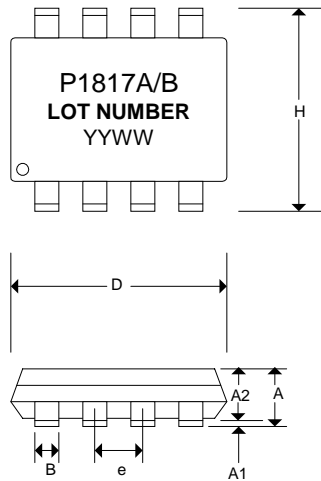

| SYMBOL | INCHES | | | MILLIMETERS | | |
|--------|-----------|-------|-------|-------------|------|------|
| | MIN | NOR | MAX | MIN | NOR | MAX |
| A | 0.057 | 0.064 | 0.071 | 1.45 | 1.63 | 1.80 |
| A1 | 0.004 | 0.007 | 0.010 | 0.10 | 0.18 | 0.25 |
| A2 | 0.053 | 0.061 | 0.069 | 1.35 | 1.55 | 1.75 |
| B | 0.012 | 0.016 | 0.020 | 0.31 | 0.41 | 0.51 |
| C | 0.004 | 0.006 | 0.001 | 0.10 | 0.15 | 0.25 |
| D | 0.186 | 0.194 | 0.202 | 4.72 | 4.92 | 5.12 |
| E | 0.148 | 0.156 | 0.164 | 3.75 | 3.95 | 4.15 |
| e | 0.050 BSC | | | 1.27 BSC | | |
| H | 0.224 | 0.236 | 0.248 | 5.70 | 6.00 | 6.30 |
| L | 0.012 | 0.020 | 0.028 | 0.30 | 0.50 | 0.70 |
| a | 0° | 5° | 8° | 0° | 5° | 8° |

Note: Controlling dimensions are millimeters.
SOIC - 0.074 grams unit weight

Mechanical Package Outline (8-Pin TSSOP)

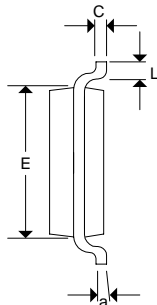
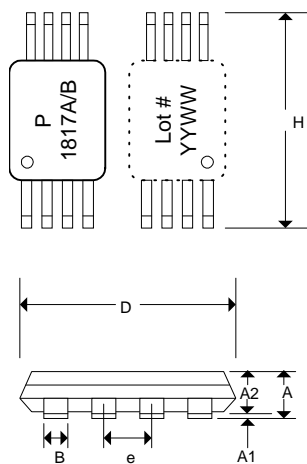

| SYMBOL | INCHES | | | MILLIMETERS | | |
|--------|-----------|-------|-------|-------------|------|------|
| | MIN | NOR | MAX | MIN | NOR | MAX |
| A | - | - | 0.047 | - | - | 1.10 |
| A1 | 0.002 | - | 0.006 | 0.05 | - | 0.15 |
| A2 | 0.031 | 0.039 | 0.041 | 0.80 | 1.00 | 1.05 |
| B | 0.007 | - | 0.012 | 0.19 | - | 0.30 |
| C | 0.004 | - | 0.008 | 0.09 | - | 0.20 |
| D | 0.114 | 0.118 | 0.122 | 2.90 | 3.00 | 3.10 |
| E | 0.169 | 0.173 | 0.177 | 4.30 | 4.40 | 4.50 |
| e | 0.026 BSC | | | 0.65 BSC | | |
| H | 0.244 | 0.252 | 0.260 | 6.20 | 6.40 | 6.60 |
| L | 0.018 | 0.024 | 0.030 | 0.45 | 0.60 | 0.75 |
| a | 0° | - | 8° | 0° | - | 8° |

Note: Controlling dimensions are millimeters.
TSSOP - 0.034 grams unit weight



Ordering Information

| Order Number | Marking | Input frequency (MHz) | Package type | Quantity/reel | Temperature |
|--------------|---------|-----------------------|--------------------------|---------------|---------------|
| P1817A-08ST | P1817A | 20 – 32 | 8-pin SOIC, tube | | 0° C to 70° C |
| P1817A-08SR | P1817A | 20 – 32 | 8-pin SOIC, tape & reel | 2,500 | 0° C to 70° C |
| P1817A-08TT | P1817A | 20 – 32 | 8-pin TSSOP, tube | | 0° C to 70° C |
| P1817A-08TR | P1817A | 20 – 32 | 8-pin TSSOP, tape & reel | 2,500 | 0° C to 70° C |
| P1817B-08ST | P1817B | 10 – 20 | 8-pin SOIC, tube | | 0° C to 70° C |
| P1817B-08SR | P1817B | 10 – 20 | 8-pin SOIC, tape & reel | 2,500 | 0° C to 70° C |
| P1817B-08TT | P1817B | 10 – 20 | 8-pin TSSOP, tube | | 0° C to 70° C |
| P1817B-08TR | P1817B | 10 – 20 | 8-pin TSSOP, tape & reel | 2,500 | 0° C to 70° C |

Licensed under U.S. Patent Nos. 5,488,627 and 5,631,920.

Preliminary datasheet. Specifications subject to change without notice.