



LXT901A/907A

Universal 3.3V Ethernet Transceiver

Datasheet

The LXT901A and LXT907A are new generation Universal Ethernet Transceivers with improved noise immunity and output filtering. The feature set of the LXT901A/907A has been streamlined, removing Remote Signaling capabilities. The LXT901A and LXT907A provide all the active circuitry to interface most standard IEEE 802.3 controllers to either the 10BASE-T media or Attachment Unit Interface (AUI).

The LXT901A and LXT907A are identical except for the function of one pin. The LXT901A, with selectable termination impedance, allows the use of either shielded or unshielded twisted-pair cable. The LXT907A offers a Signal Quality Error Disable (DSQE) function.

LXT901A and LXT907A functions include Manchester encoding/decoding, receiver squelch and transmit pulse shaping, jabber, link testing, and reversed polarity detection/correction.

Applications

- Access devices (DSL, Cable Modems, and Set-top Boxes)
- Routers/Bridges/Switches/Hubs
- Telecom Backplane
- USB to Ethernet Converters

Product Features

Functional Features

- Integrated Filters - Simplify FCC Compliance
- Integrated Manchester Encoder/Decoder
- 10BASE-T Transceiver
- AUI Transceiver
- Full-Duplex Capable (20 Mbps)

Diagnostic Features

- Four LED Drivers
- AUI/RJ-45 Loopback

Convenience Features

- Automatic/Manual AUI/RJ-45 Selection
- Automatic Polarity Correction
- SQE Disable function (*LXT907A*)
- Programmable Impedance Driver (*LXT901A*)
- Single 3.3V operation
- Power-Down Mode and four loopback modes
- Available in 64-pin LQFP and 44-pin PLCC packages
- Commercial (0 to +70°C)



Information in this document is provided in connection with Intel® products. No license, express or implied, by estoppel or otherwise, to any intellectual property rights is granted by this document. Except as provided in Intel's Terms and Conditions of Sale for such products, Intel assumes no liability whatsoever, and Intel disclaims any express or implied warranty, relating to sale and/or use of Intel products including liability or warranties relating to fitness for a particular purpose, merchantability, or infringement of any patent, copyright or other intellectual property right. Intel products are not intended for use in medical, life saving, or life sustaining applications.

Intel may make changes to specifications and product descriptions at any time, without notice.

Designers must not rely on the absence or characteristics of any features or instructions marked "reserved" or "undefined." Intel reserves these for future definition and shall have no responsibility whatsoever for conflicts or incompatibilities arising from future changes to them.

The LXT901A/907A may contain design defects or errors known as errata which may cause the product to deviate from published specifications. Current characterized errata are available on request.

Contact your local Intel sales office or your distributor to obtain the latest specifications and before placing your product order.

Copies of documents which have an ordering number and are referenced in this document, or other Intel literature may be obtained by calling 1-800-548-4725 or by visiting Intel's website at <http://www.intel.com>.

Copyright © Intel Corporation, 2001

*Third-party brands and names are the property of their respective owners.

Contents

1.0	Pin Assignments and Signal Descriptions	8
2.0	Functional Description	11
2.1	Controller Compatibility Modes	11
2.2	Transmit Function.....	12
2.2.1	Jabber Control Function	13
2.2.2	SQE Function	13
2.2.2.1	SQE Disable Function (LXT907A only)	14
2.3	Receive Function.....	14
2.3.1	Polarity Reverse Function	15
2.3.2	Collision Detection Function.....	15
2.4	Loopback Functions	16
2.4.1	Standard TP Loopback.....	16
2.4.2	Forced TP Loopback.....	16
2.4.3	AUI Loopback.....	17
2.4.4	External Loopback.....	17
2.5	Link Integrity Test Function	17
2.6	Link Pulse Transmission	19
3.0	Application Information	19
3.1	Twisted-Pair Impedance Matching.....	19
3.2	Crystal Information	19
3.3	Magnetics Information.....	19
3.4	Typical Applications.....	20
3.4.1	Auto Port Select with External Loopback Control.....	20
3.4.2	Full-Duplex Support.....	22
3.4.3	Dual Network Support - 10Base-T and Token Ring	23
3.4.4	Manual Port Select with Link Test Function	24
3.4.5	Three Media Application.....	26
3.4.6	AUI Encoder/Decoder Only	27
3.4.7	150W Shielded Twisted-Pair Only (LXT901A only).....	28
4.0	Test Specifications	29
4.1	Timing Diagrams for Mode 1 (MD1 = Low, MD0 = Low) Figures 17 - 22	33
4.2	Timing Diagrams for Mode 2 (MD1 = Low, MD0 = High) Figures 23 - 28	35
4.3	Timing Diagrams for Mode 3 (MD1 = High, MD0 = Low) Figures 29 - 36	37
4.4	Timing Diagrams for Mode 4 (MD1 = High, MD0 = High) Figures 37 - 42	40
5.0	Mechanical Specifications	42
A	Ordering Information	45

Figures

1	LXT901A/907A Block Diagram	7
2	LXT901A/907A Pin Assignments	8
3	TPO Output Waveform	12
4	Jabber Control Function	13
5	SQE Function	14
6	Collision Detection Function	16
7	Link Integrity Test Function	18
8	Transmitted Link Integrity Pulse Timing	19
9	LAN Adapter Board - Auto Port Select with External LPBK Control	21
10	Full-Duplex Operation	22
11	380C26 Interface for Dual Network Support of 10BASE-T and Token Ring	23
12	LAN Adapter Board - Manual Port Select with Link Test Function.....	24
13	Manual Port Select with Seeq 8005 Controller	25
14	Three Media Application	26
15	AUI Encoder/Decoder Only Application	27
16	150 W Shielded Twisted-Pair Only Application (LXT901A)	28
17	Mode 1 RCLK/Start-of-Frame Timing	33
18	Mode 1 RCLK/End-of-Frame Timing	33
19	Mode 1 Transmit Timing	34
20	Mode 1 Collision Detect Timing	34
21	Mode 1 COL/CI Output Timing	34
22	Mode 1 Loopback Timing	34
23	Mode 2 RCLK/Start-of-Frame Timing	35
24	Mode 2 RCLK/End-of-Frame Timing	35
25	Mode 2 Transmit Timing	36
26	Mode 2 Collision Detect Timing	36
27	Mode 2 COL/CI Output Timing	36
28	Mode 2 Loopback Timing	36
29	Mode 3 RCLK/Start-of-Frame Timing (LXT901A)	37
30	Mode 3 RCLK/End-of-Frame Timing (LXT901A)	37
31	Mode 3 RCLK/Start-of-Frame Timing (LXT907A)	38
32	Mode 3 RCLK/End-of-Frame Timing (LXT907A)	38
33	Mode 3 Transmit Timing	39
34	Mode 3 Collision Detect Timing	39
35	Mode 3 COL/CI Output Timing	39
36	Mode 3 Loopback Timing	39
37	Mode 4 RCLK/Start-of-Frame Timing	40
38	Mode 4 RCLK/End-of-Frame Timing	40
39	Mode 4 Transmit Timing	41
40	Mode 4 Collision Detect Timing	41
41	Mode 4 COL/CI Output Timing	41
42	Mode 4 Loopback Timing	41
43	44-Pin PLCC	42
44	64-Pin LQFP	43
45	Ordering Information - Sample	45

Tables

1	LXT901A/907A Signal Descriptions	9
2	Controller Compatibility Modes	12
3	Suitable Crystals	19
4	Absolute Maximum Values.....	29
5	Recommended Operating Conditions	29
6	I/O Electrical Characteristics	29
7	AUI Electrical Characteristics	30
8	TP Electrical Characteristics	30
9	Switching Characteristics	31
10	RCLK/Start-of-Frame Timing.....	31
11	RCLK/End-of-Frame Timing.....	32
12	Transmit Timing.....	32
13	Collision, COL/CI Output and Loopback Timing.....	32
14	Product Information	45

Revision History

Date	Revision	Page	Description
June 2001	002	1	New items under "Applications"
		21	Figure 9: Added 0.1 μ F label to capacitor at bottom of graphic.
		22	Figure 10: Added 0.1 μ F label to capacitor at bottom of graphic.
		23	Figure 11 Added 0.1 μ F label to capacitor at bottom of graphic.
		24	Figure 12: Added 0.1 μ F label to capacitor at bottom of graphic.
		25	Figure 13: Added 0.1 μ F label to capacitor at bottom of graphic.
		29	Added 2nd para under Test Specification regarding Quality and Reliability information.
		29	Removed "Ambient operating temperature" from Absolute Maximum Values table.
		45	Added Appendix: Product Ordering Information

1.0 Pin Assignments and Signal Descriptions

Figure 2. LXT901A/907A Pin Assignments

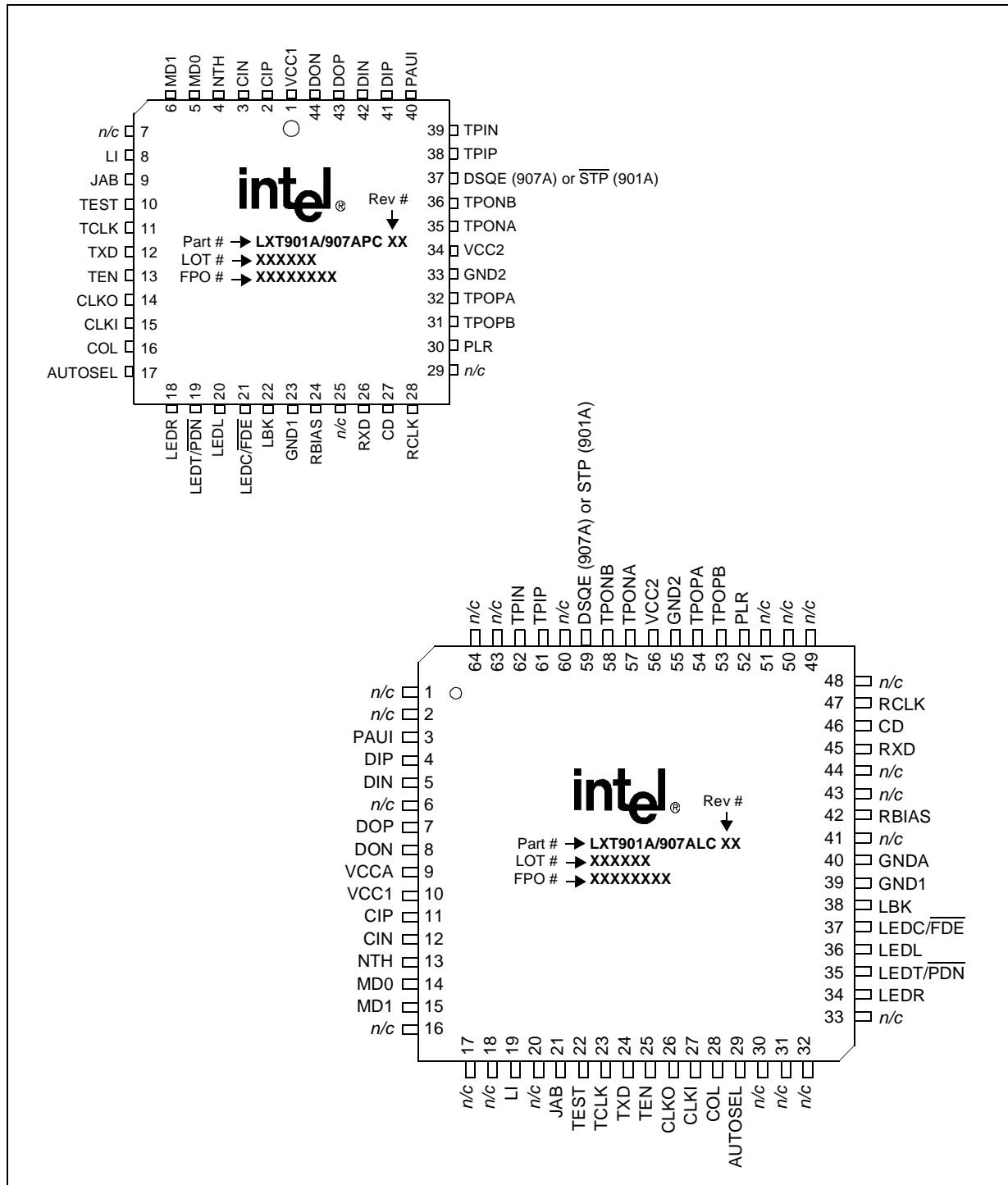

Table 1. LXT901A/907A Signal Descriptions

Pin #		Symbol	I/O ¹	Description
PLCC	LQFP			
1 34	10 56	VCC1 VCC2	– –	Power Supply 1 and 2. Power supply inputs of +3.3 volts.
–	9	VCCA	–	Analog Supply. (+3.3V)
2 3	11 12	CIP CIN	I I	AUI Collision Pair. Differential input to the AUI transceiver CI circuit. The input is collision signaling or SQE.
4	13	NTH	I	Normal Threshold. Selects normal or reduced threshold. When NTH is High, the normal TP squelch threshold is in effect. When NTH is Low, the normal TP squelch threshold is reduced by 4.5 dB.
5 6	14 15	MD0 MD1	I I	Mode Select 0 (MD0) and Mode Select 1 (MD1). Mode select pins determine the controller compatibility mode in accordance with Table 2 .
8	19	LI	I	Link Test Enable. Controls Link Integrity Test; enabled when LI = High, disabled when LI = Low
9	21	JAB	O	Jabber Indicator. Output goes High to indicate Jabber state.
10	22	TEST	I	Test. For Intel internal use only. It is recommended to tie this pin High externally.
11	23	TCLK	O	Transmit Clock. A 10 MHz clock output. This clock signal should be directly connected to the transmit clock input of the controller.
12	24	TXD	I	Transmit Data. Input signal containing NRZ data to be transmitted on the network. Connect TXD directly to the transmit data output of the controller.
13	25	TEN	I	Transmit Enable. Enables data transmission and starts the watchdog timer. Synchronous to TCLK (see Test Specifications for details).
14 15	26 27	CLKO CLKI	O I	Crystal Oscillator. A 20 MHz crystal must be connected across these pins, or a 20 MHz clock applied at CLKI with CLKO left open.
16	28	COL	O	Collision Detect. Output which drives the collision detect input of the controller.
17	29	AUTOSEL	I	Automatic Port Select. When High, automatic port selection is enabled (the 901A/907A defaults to the AUI port only if TP link integrity = Fail). When Low, manual port selection is enabled (the PAUI pin determines the active port).
18	34	LEDR	OD	Receive LED. Open drain driver for the receive indicator LED. Output is pulled Low during receive.
19	35	LEDT/ PDN	OD	Transmit LED (LEDT)/Power-Down (PDN). Open drain driver for the transmit indicator. Output is pulled Low during transmit. Do not allow this pin to float. If unused, tie High. If externally pulled Low, the LXT901A/907A goes to power-down state.
20	36	LEDL	OD	Link LED. Open drain driver for link integrity indicator. Output is pulled Low during link test pass. If externally tied Low, internal circuitry is forced to “Link Pass” state and the LXT901A/907A transmits link test pulses continuously.

1. I/O Column Coding: I = Input, O = Output, OD = Open Drain

Table 1. LXT901A/907A Signal Descriptions (Continued)

Pin #		Symbol	I/O ¹	Description
PLCC	LQFP			
21	37	LEDC/ FDE	OD	Collision LED (LEDC)/Full-Duplex Enable (FDE). Open drain driver for the collision indicator pulls Low during collision. LED "On" (i.e., Low output) time is extended by approximately 100 ms. If externally tied Low, enables full-duplex operation by disabling the internal TP loopback and collision detection circuits in anticipation of external twisted-pair loopback or full-duplex operation. If this pin is not used, tie High or directly to Vcc.
22	38	LBK	I	Loopback. Enables internal loopback mode. Refer to Functional Description for details.
23 33	39 55	GND1 GND2	– –	Ground Returns 1 and 2. Grounds
–	40	GNDA	–	Analog Ground.
24	42	RBIAS	I	Bias Control. A 12.4 kΩ 1% resistor to ground at this pin controls operating circuit bias.
26	45	RXD	O	Receive Data. Output signal. Connect directly to the receive data input of the controller.
27	46	CD	O	Carrier Detect. An output to notify the controller of activity on the network.
28	47	RCLK	O	Receive Clock. A recovered 10 MHz clock that is synchronous to the received data. Connect to the controller receive clock input.
30	52	PLR	O	Polarity Reverse. Output goes High to indicate reversed polarity at the twisted-pair input.
31 36 32 35	53 58 54 57	TPOPB TAPONB TPOPA TPONA	O O O O	Twisted-Pair Transmit Pairs A & B. Two differential driver pair outputs (A and B) to the twisted-pair cable. The outputs are pre-equalized. Each pair must be shorted together and tied to the transformer through a 24.9Ω 1% series resistor to match impedance of 100Ω. Refer to Figure 16 on page 28 in the Applications Section for information on 150Ω configurations.
37	59	$\overline{\text{STP}}$	I	STP Select (LXT901A only). When $\overline{\text{STP}}$ is Low, 150Ω termination for shielded twisted-pair is selected. When $\overline{\text{STP}}$ is High, 100Ω termination for unshielded twisted-pair is selected. LXT907A is designed for 100Ω unshielded twisted-pair termination (not selectable).
		DSQE	I	Disable SQE (LXT907A only). When DSQE is High, the SQE function is disabled. When DSQE is Low, the SQE function is enabled. SQE must be disabled for normal operation in Hub/Switch applications. LXT901A operates with SQE enabled (not selectable).
38 39	61 62	TPIP TPIN	I I	Twisted-Pair Receive Pair. A differential input pair from the twisted-pair cable. Receive filter is integrated on-chip. No external filters are required.
40	3	PAUI	I	Port/AUI Select. In Manual Port Select mode (AUTSEL Low), PAUI selects the active port. When PAUI is High, the AUI port is selected. When PAUI is Low, the TP port is selected. In Auto Port Select mode, PAUI must be tied to ground.
1. I/O Column Coding: I = Input, O = Output, OD = Open Drain				

Table 1. LXT901A/907A Signal Descriptions (Continued)

Pin #		Symbol	I/O ¹	Description
PLCC	LQFP			
41 42	4 5	DIP DIN	I I	AUI Receive Pair. Differential input pair from the AUI transceiver DI circuit. The input is Manchester encoded.
43 44	7 8	DOP DON	O O	AUI Transmit Pair. A differential output driver pair for the AUI transceiver cable. The output is Manchester encoded.
7, 25, 29	1, 2, 6, 16, 17, 18, 20, 30, 31, 32, 33, 41, 43, 44, 48, 49, 50, 51, 60, 63, 64	N/C	–	No Connect (Internally tied to ground).

1. I/O Column Coding: I = Input, O = Output, OD = Open Drain

2.0 Functional Description

The LXT901A/907A Universal Ethernet Interface Transceivers perform the physical layer signaling (PLS) and Media Attachment Unit (MAU) functions as defined by the IEEE 802.3 specification. They function as a PLS-Only device (for use with 10BASE-2 or 10BASE-5 coaxial cable networks) or as an Integrated PLS/MAU (for use with 10BASE-T twisted-pair networks). In addition to standard 10 Mbps operation, they also support full-duplex 20 Mbps operation.

The LXT901A/907A interfaces a back-end controller to either an AUI drop cable or a twisted-pair (TP) cable. The controller interface includes a transmit and receive clock and NRZ data channels, as well as mode control logic and signaling. The AUI interface comprises three circuits: Data Output (DO), Data Input (DI) and Collision (CI). The twisted-pair interface is comprised of two circuits: Twisted-Pair Input (TPI) and Twisted-Pair Output (TPO). In addition to the three basic interfaces, the LXT901A/907A contains an internal crystal oscillator and four LED drivers for visual status reporting.

Functions are defined from the back-end controller side of the interface. The Transmit function refers to data transmitted by the back-end to the AUI cable (PLS-Only mode) or to the twisted-pair network (Integrated PLS/MAU mode). The Receive function refers to data received by the back-end from the AUI cable (PLS-Only) or from the twisted-pair network (Integrated PLS/MAU mode). In the integrated PLS/MAU mode, the LXT901A/907A performs all required MAU functions defined by the IEEE 802.3 10BASE-T specification, such as collision detection, link integrity testing, signal quality error messaging, jabber control, and loopback. In the PLS-only mode, the LXT901A/907A receives incoming signals from the AUI DI circuit, with ± 18 ns of jitter, and drives the AUI DO circuit.

2.1 Controller Compatibility Modes

The LXT901A/907A are compatible with most industry standard controllers, including devices produced by Motorola, AMD, Intel, Fujitsu, National Semiconductor, Seeq, and Texas Instruments. Four different control signal timing and polarity schemes (Modes 1 through 4) are required to

achieve this compatibility. Mode select pins (MD0 and MD1) determine controller compatibility modes as listed in Table 2. Refer to Test Specifications for a complete set of timing diagrams for each mode.

Table 2. Controller Compatibility Modes

Controller Mode	Setting	
	MD1	MD0
Mode 1 For Motorola 68EN360, MPC860, Advanced Micro Devices AM7990 or compatible controllers	Low	Low
Mode 2 For Intel 82596 or compatible controllers ¹	Low	High
Mode 3 For Fujitsu MB86950, MB86960 or compatible controllers (Seeq 8005) ²	High	Low
Mode 4 For National Semiconductor 8390 or compatible controllers (TI TMS380C26)	High	High
1. Refer to Intel Application Note 51 when designing with Intel Controllers. 2. SEEQ controllers require inverters on CLK1, LBK, RCLK and COL.		

2.2 Transmit Function

The LXT901A/907A receives NRZ data from the controller at the TXD input, as shown in Figure 1, “LXT901A/907A Block Diagram” on page 7, and passes it through a Manchester encoder. The encoded data is then transferred to either the AUI cable (the DO circuit) or the twisted-pair network (the TPO circuit). The advanced integrated pulse shaping and filtering network produces the output signal on TPON and TPOP as shown in Figure 3. The TPO output is pre-distorted and pre-filtered to meet the 10BASE-T jitter template. An internal continuous resistor-capacitor filter is used to remove any high-frequency clocking noise from the pulse shaping circuitry. Integrated filters simplify the design work required for FCC compliant EMI performance. During idle periods, the LXT901A/907A transmits link integrity test pulses on the TPO circuit (if LI is enabled and integrated, PLS/ MAU mode is selected). External resistors control the termination impedance for the LXT907A. External resistors and the \overline{STP} pin control termination impedance on the LXT901A.

Figure 3. TPO Output Waveform

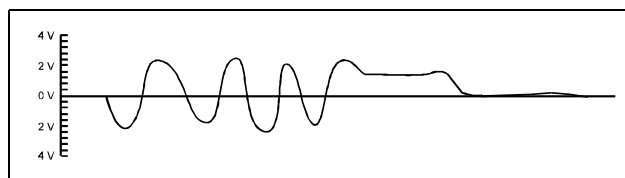

2.2.1 Jabber Control Function

Figure 4 is a state diagram of the LXT901A/907A jabber control function. The on-chip watchdog timer prevents the DTE from locking into a continuous transmit mode. When a transmission exceeds the time limit, the watchdog timer disables the transmit and loopback functions, and activates the JAB pin. Once the LXT901A/907A is in the jabber state, the TXD circuit must remain idle for a period of 250 to 750 ms before it exits the jabber state.

Figure 4. Jabber Control Function

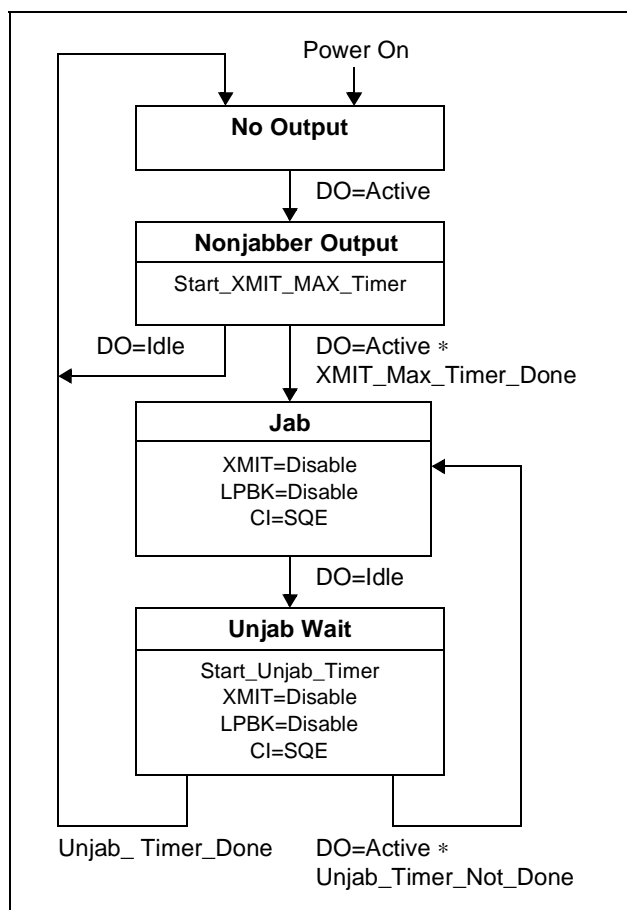

2.2.2 SQE Function

In the integrated PLS/MAU mode, the LXT901A/907A supports the signal quality error (SQE) function as shown in Figure 5 on page 14, although the SQE function can be disabled on the LXT907A. After every successful transmission on the 10BASE-T network, when SQE is enabled, the LXT901A/907A transmits the SQE signal for 10 bit times \pm 5 bit times over the internal CI circuit, which is indicated on the COL pin of the device. When using the AUI of the LXT901A/907A, the SQE function is determined by the external MAU attached.

2.2.2.1 SQE Disable Function (LXT907A only)

SQE must be disabled for normal operation in hub and switch applications. The LXT907A is configured with an SQE Disable function. The SQE function is disabled when DSQE is set High, and enabled when DSQE is Low.

Figure 5. SQE Function

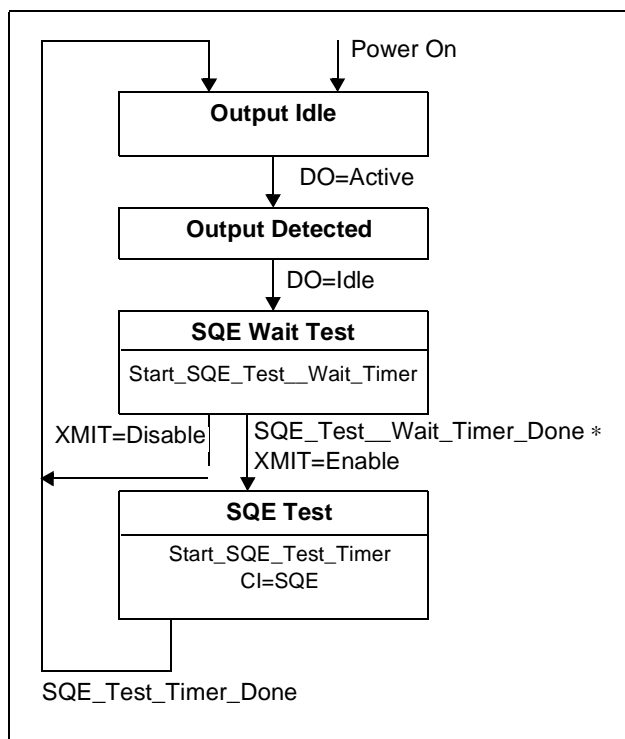

2.3 Receive Function

The LXT901A/907A receive function acquires timing and data from the twisted-pair network (the TPI circuit) or from the AUI (the DI circuit). Valid received signals are passed through the on-chip filters and Manchester decoder, then output as decoded NRZ data and receive timing on the RXD and RCLK pins, respectively.

An internal RC filter and an intelligent squelch function discriminate noise from link test pulses and valid data streams. The receive function is activated only by valid data streams above the squelch level and with proper timing. If the differential signal at the TPI or the DI circuit inputs falls below 75 percent of the threshold level (unsquelched) for 8 bit times (typical), the LXT901A/907A receive function enters the idle state. If the polarity of the TPI circuit is reversed, LXT901A/907A detects the polarity reverse and reports it via the PLR output. The LXT901A/907A automatically corrects reversed polarity.

2.3.1 Polarity Reverse Function

The LXT901A/907A polarity reverse function uses both link pulses and end-of-frame data to determine the polarity of the received signal. A reversed polarity condition is detected when eight opposite receive link pulses are detected without receipt of a link pulse of the expected polarity. Reversed polarity is also detected if four frames are received with a reversed start-of-idle. Whenever a correct polarity frame or a correct link pulse is received, these two counters are reset to zero. If the LXT901A/907A enters the link fail state and no valid data or link pulses are received within 96 to 128 ms, the polarity is reset to the default non-flipped condition. If Link Integrity Testing is disabled, polarity detection is based only on received data. Polarity correction is always enabled.

2.3.2 Collision Detection Function

The collision detection function operates on the twisted-pair side of the interface. For standard (half-duplex) 10BASE-T operation, a collision is defined as the simultaneous presence of valid signals on both the TPI circuit and the TPO circuit. The LXT901A/907A reports collisions to the back-end via the COL pin. If the TPI circuit becomes active while there is activity on the TPO circuit, the TPI data is passed to the back-end over the RXD circuit, disabling normal loopback. [Figure 6 on page 16](#) is a state diagram of the LXT901A/907A collision detection function. Refer to Test Specifications for collision detection and COL/CI output timing.

Note: For full-duplex operation on the TP or AUI port, the collision detection circuitry must be disabled by setting $\overline{\text{FDE}}$ Low.

Figure 6. Collision Detection Function

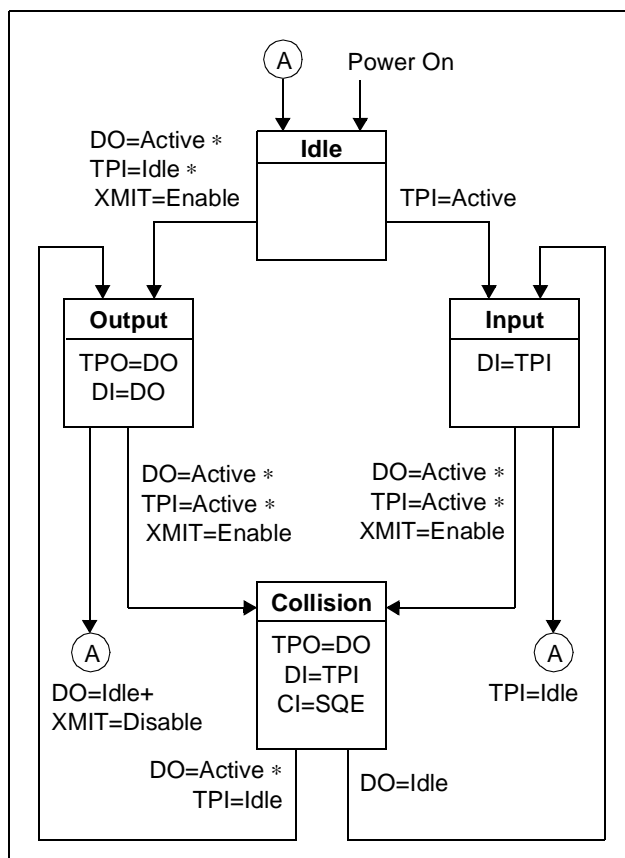

2.4 Loopback Functions

2.4.1 Standard TP Loopback

The LXT901A/907A provides the standard loopback function defined by the 10BASE-T specification for the twisted-pair port. The loopback function operates in conjunction with the transmit function. Data transmitted by the back-end is internally looped back within the LXT901A/907A from the TXD pin through the Manchester encoder/decoder to the RXD pin and returned to the back-end. This standard loopback function is disabled when a data collision occurs, clearing the RXD circuit for the TPI data. Standard loopback is also disabled during link fail and jabber states. The LXT901A/907A also provides three additional loopback functions.

2.4.2 Forced TP Loopback

“Forced” twisted-pair loopback is controlled by the LBK pin. When the twisted-pair port is selected and LBK is High, twisted-pair loopback is “forced”, overriding collisions on the twisted-pair circuit. When LBK is Low, normal loopback is in effect.

2.4.3 AUI Loopback

AUI loopback is also controlled by the LBK pin. When the AUI port is selected and LBK is High, data transmitted by the back-end is internally looped back from the TXD pin through the Manchester encoder/decoder to the RXD pin. When LBK is Low, no AUI loopback occurs.

2.4.4 External Loopback

An external loopback mode, useful for system-level testing, is controlled by the LEDC/ $\overline{\text{FDE}}$ pin. When LEDC/ $\overline{\text{FDE}}$ is tied Low, the LXT901A/907A disables the collision detection and internal loopback circuits, to allow external loopback. External loopback mode can be set on either twisted-pair or AUI ports.

2.5 Link Integrity Test Function

Figure 7 on page 18 is a state diagram of the LXT901A/907A Link Integrity test function. The link integrity test is used to determine the status of the receive side twisted-pair cable. Link integrity testing is enabled when the LI pin is tied High. When enabled, the receiver recognizes link integrity pulses which are transmitted in the absence of receive traffic. If no serial data stream or link integrity pulses are detected within 50 - 150 ms, the chip enters a link fail state and disables the transmit and normal loopback functions. The LXT901A/907A ignores any link integrity pulse with an interval less than 2 - 7 ms. The LXT901A/907A will remain in the link fail state until it detects either a serial data packet or two or more link integrity pulses.

Figure 7. Link Integrity Test Function

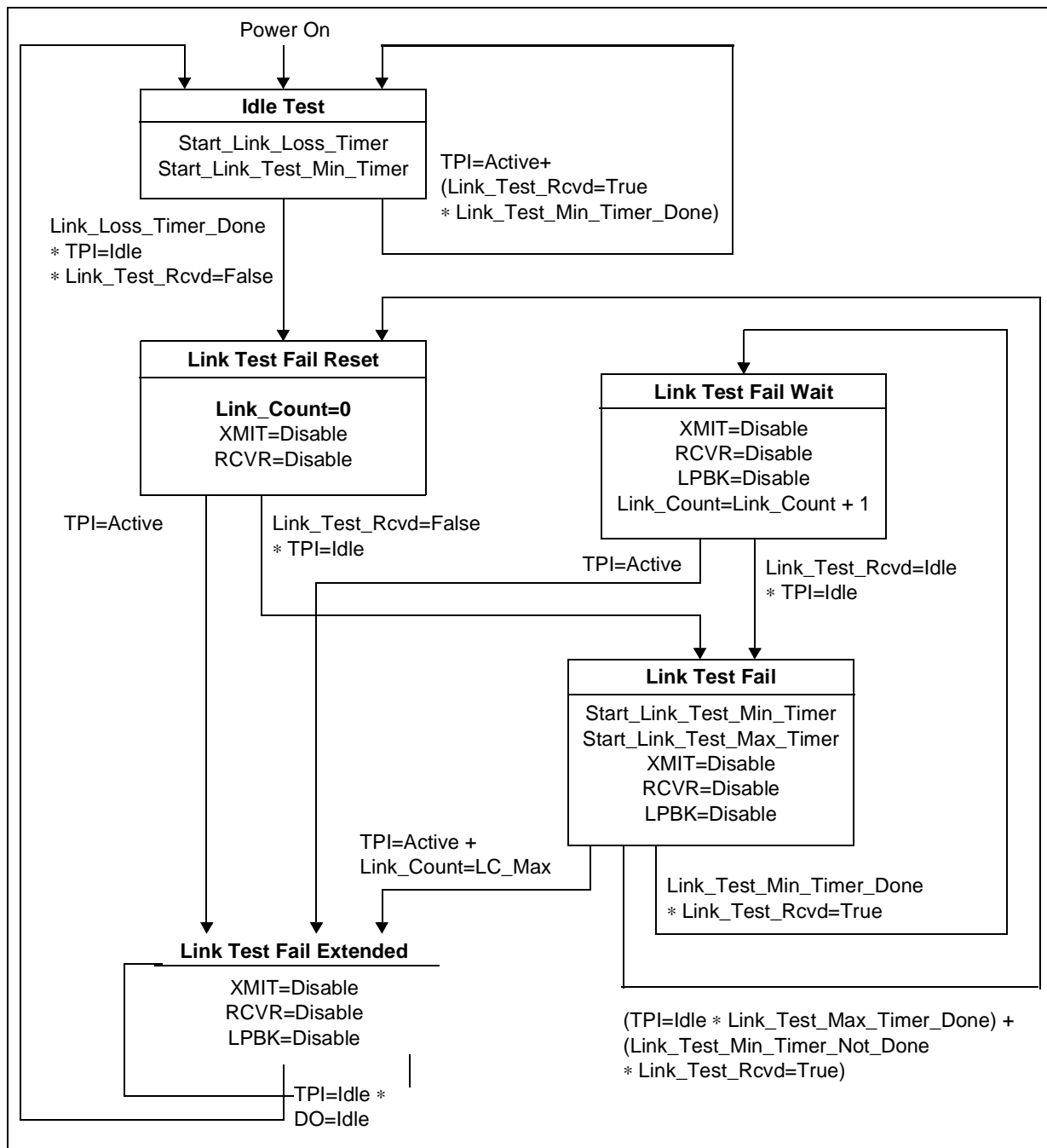

2.6 Link Pulse Transmission

When not transmitting data, the LXT901A/907A transmits IEEE 802.3-compliant standard link pulses. Figure 8 shows the link integrity pulse timing.

Figure 8. Transmitted Link Integrity Pulse Timing

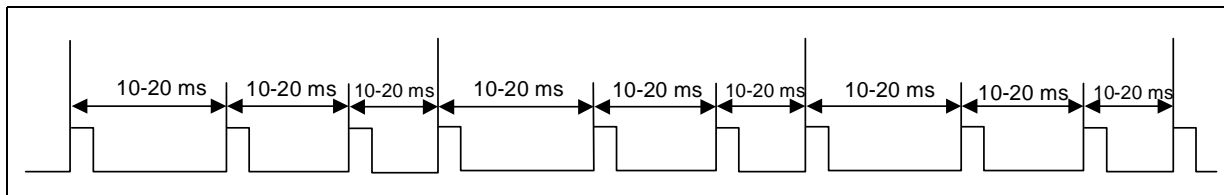

3.0 Application Information

3.1 Twisted-Pair Impedance Matching

Resistors must be installed on each input and output pair to match impedance of the network media being used. The LXT907A is configured with 100Ω termination for Unshielded Twisted-Pair (UTP). In this case, the positive and negative sides of both output pairs are shorted together (TPOPA/TPOPB and TPONA/TPONB) and tied to the transformer through a 24.9Ω 1% series resistor.

The LXT901A is designed with an \overline{STP} Select pin that allows the device to match both 100Ω and 150Ω media. A dual resistor combination can be configured to accommodate either line termination as shown in Figure 16 on page 28. When 100Ω termination is selected, both A and B pairs are driven in parallel. When 150Ω termination is selected, the B pair is tri-stated and only the A pair is driven.

3.2 Crystal Information

Designers should test and validate crystals before committing to a specific component. Based on limited evaluation, Table 3 lists some suitable crystals.

Table 3. Suitable Crystals

Manufacturer	Part Number
MTRON	MP-1
	MP-2

3.3 Magnetics Information

The LXT901A and LXT907A require a 1:1 ratio for the receive transformer and a $1:\sqrt{2}$ ratio for the transmit transformer on the twisted-pair interface. The AUI Interface requires a 1:1 ratio for the data-in, data-out, and collision-pair transformers. A cross-reference list of suitable magnetics and

part numbers is available in Application Note 73, Magnetic Manufacturers (248991-001), which can be found on the Intel web site (developer.intel.com/design/network/). Designers must test and validate all components for suitability in their applications.

3.4 Typical Applications

Figure 9 on page 21 through Figure 16 on page 28 show typical LXT901A/907A applications.

3.4.1 Auto Port Select with External Loopback Control

Figure 9 on page 21 is a typical LXT901A/907A application. The diagram groups similar pins together, but does not represent the actual LXT901A/907A pinout. The controller interface pins (transmit data, clock and enable; receive data and clock; and the collision detect, carrier detect and loopback control pins) are shown at the top left of the diagram.

Programmable option pins are grouped at the center left of the diagram. The PAUI pin is tied Low and all other option pins are tied High. This setup selects the following options:

- Automatic Port Selection (PAUI Low and AUTOSEL High)
- Normal Receive Threshold (NTH High)
- Mode 4, compatible with National NS8390 controllers (MD0 High, MD1 High)
- SQE Disabled (DSQE High for LXT907A only)
- UTP is selected ($\overline{\text{STP}}$ High for LXT901A only)
- Link Testing Enabled (LI High)

Status outputs are grouped at the lower left of the diagram. Local status outputs drive LED indicators.

Power and ground pins are shown at the bottom of the diagram. A single power supply is used for both VCC1 and VCC2, with a decoupling capacitor installed between the power and ground busses. An additional power and ground pin (VCCA and GNDA) is supported in designs using the 64-pin LQFP package. A single power supply is used for all three power and ground pins (VCC1, VCC2, VCCA) and (GND1, GND2, GNDA). Install a decoupling capacitor between each power and ground buss.

The twisted-pair and AUI interfaces are shown at the upper and lower right of the diagram, respectively. Impedance matching resistors for 100 Ω UTP are installed in each I/O pair and no external filters are required.

Figure 9. LAN Adapter Board - Auto Port Select with External LPBK Control

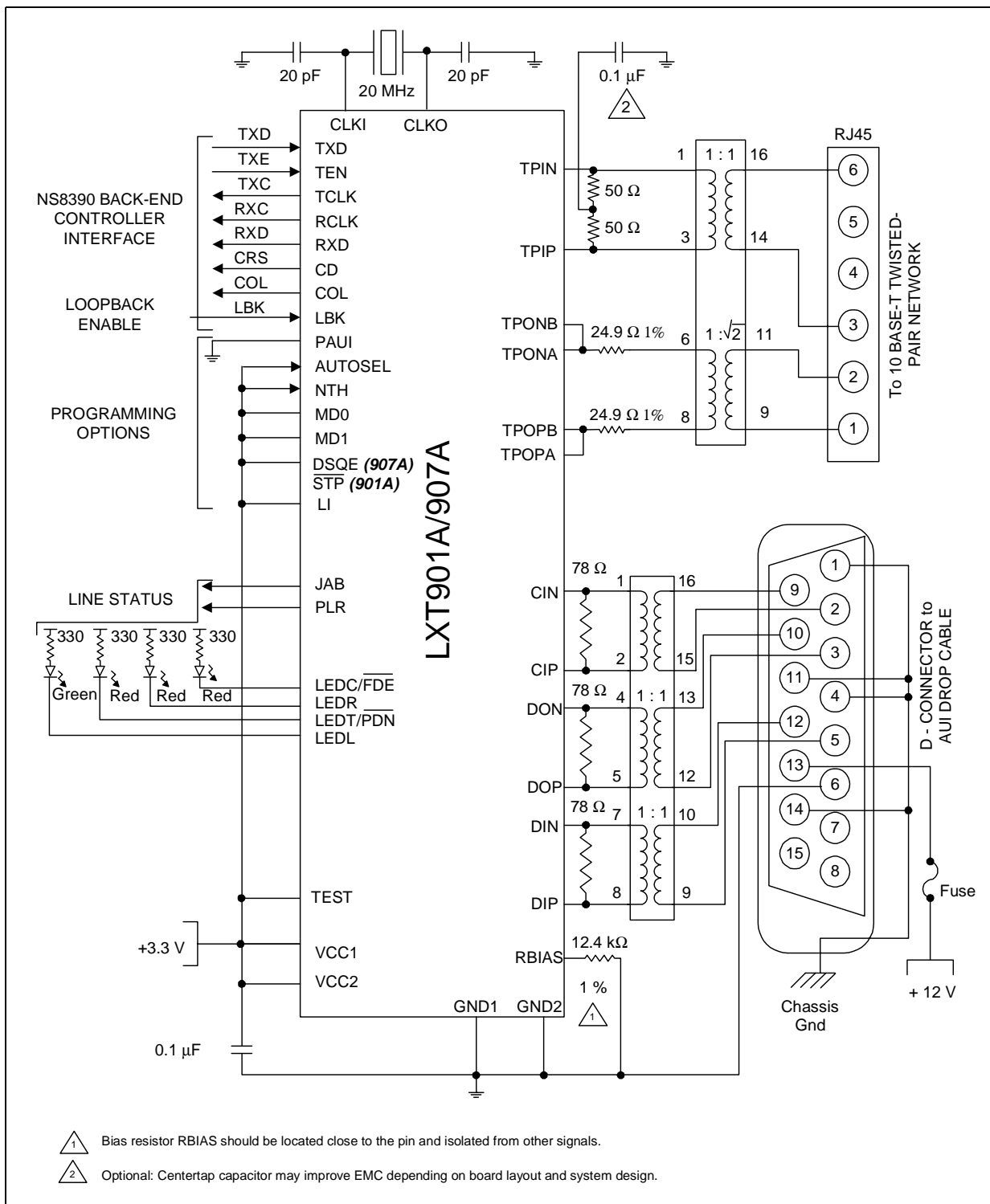

3.4.2 Full-Duplex Support

Figure 10 shows the LXT907A with a Texas Instruments 380C24 CommProcessor. The 380C24 is compatible with Mode 4 (MD0 and MD1 both High). When used with the 380C24, or other full-duplex capable controller, the LXT907A supports full-duplex Ethernet, effectively doubling the available bandwidth of the network. In this application, the SQE function is enabled (DSQE tied Low), and the AUI port is not used.

Figure 10. Full-Duplex Operation

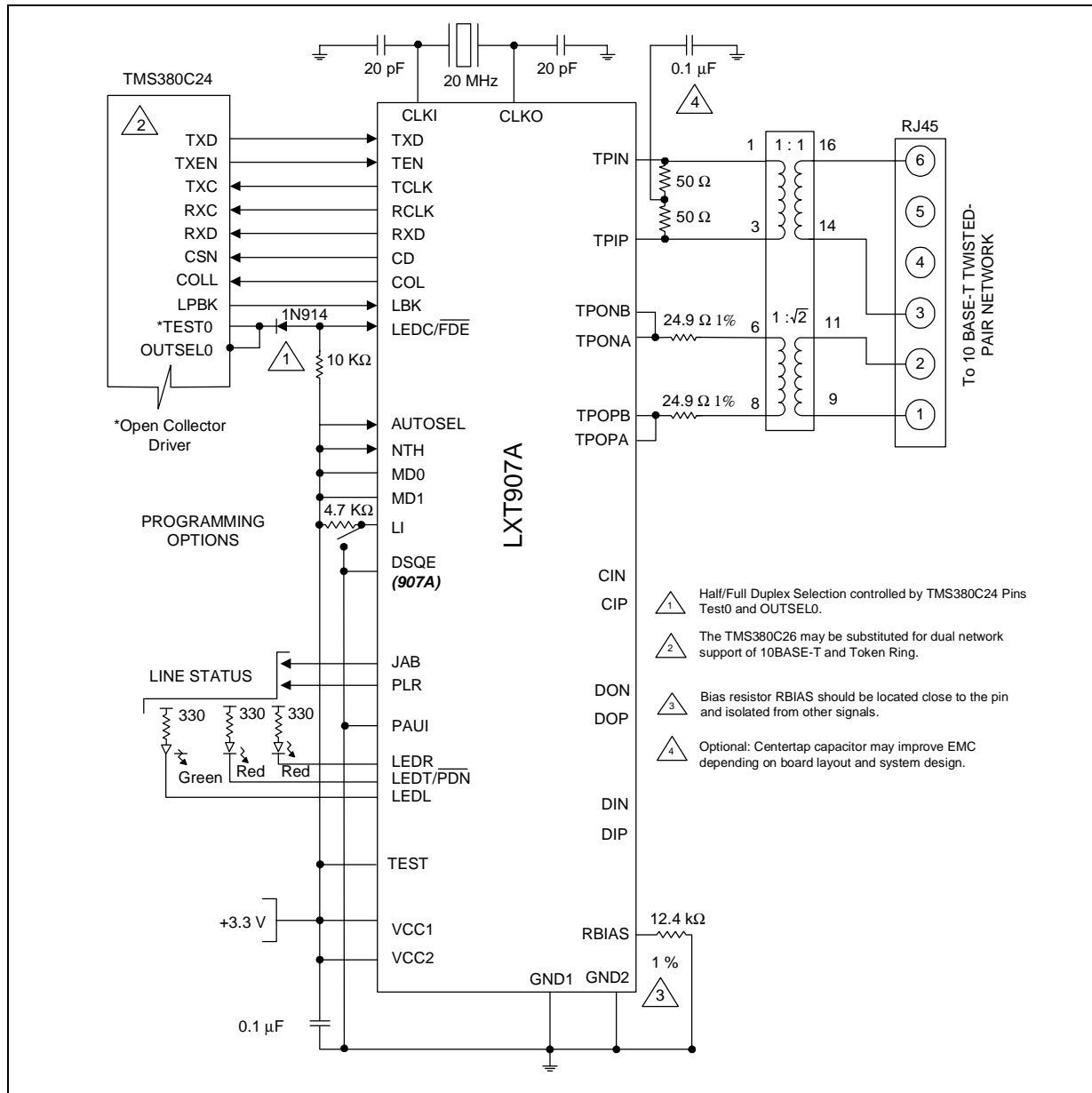

3.4.3 Dual Network Support - 10Base-T and Token Ring

Figure 11 shows the LXT901A/907A with a Texas Instruments 380C26 CommProcessor. The 380C26 is compatible with Mode 4 (MD0 and MD1 both High). When used with the 380C26, both the LXT901A/907A and a TMS38054 Token Ring transceiver can be tied to a single RJ-45, allowing dual network support from a single connector. The LXT901A/907A AUI port is not used. The DSQE pin on the LXT907A is tied Low and the \overline{STP} pin on the LXT901A is tied High.

Figure 11. 380C26 Interface for Dual Network Support of 10BASE-T and Token Ring

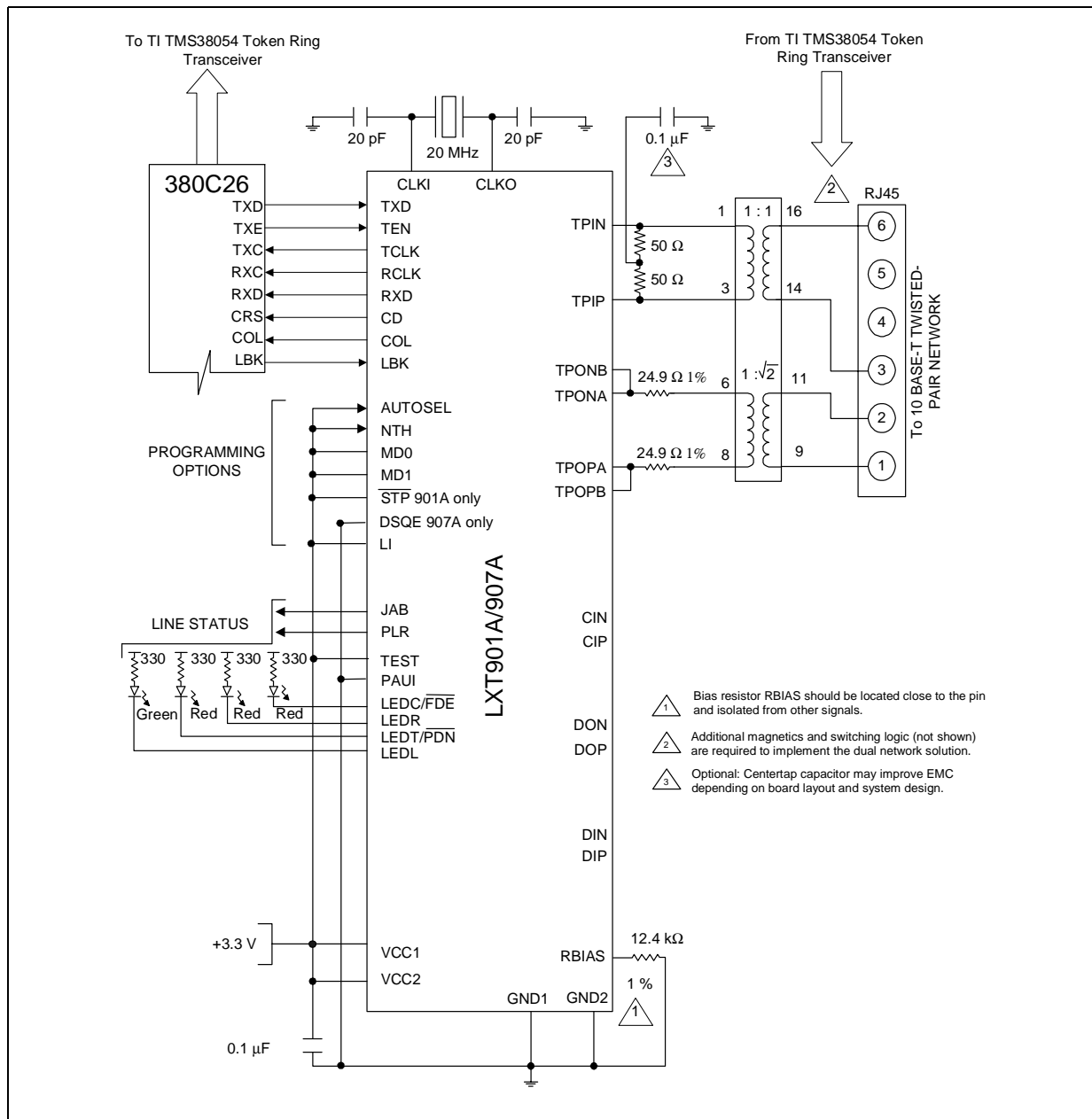

3.4.4 Manual Port Select with Link Test Function

With MD0 tied Low and MD1 tied High, the LXT901A/907A logic and framing are set to Mode 3 (compatible with Fujitsu MB86950 and MB86960, and Seeq 8005 controllers). Figure 12 shows the setup for Fujitsu controllers. Figure 13 on page 25 shows the four inverters required to interface with the Seeq 8005 controller. As seen in Figure 9 on page 21 both these Mode 3 applications show the LI pin tied High, enabling Link Testing; and the STP (LXT901A only) and NTH pins are both tied High, selecting the standard receiver threshold and 100Ω termination for unshielded TP cable. However, in these applications AUTOSEL is tied Low, allowing external port selection through the PAUI pin.

Figure 12. LAN Adapter Board - Manual Port Select with Link Test Function

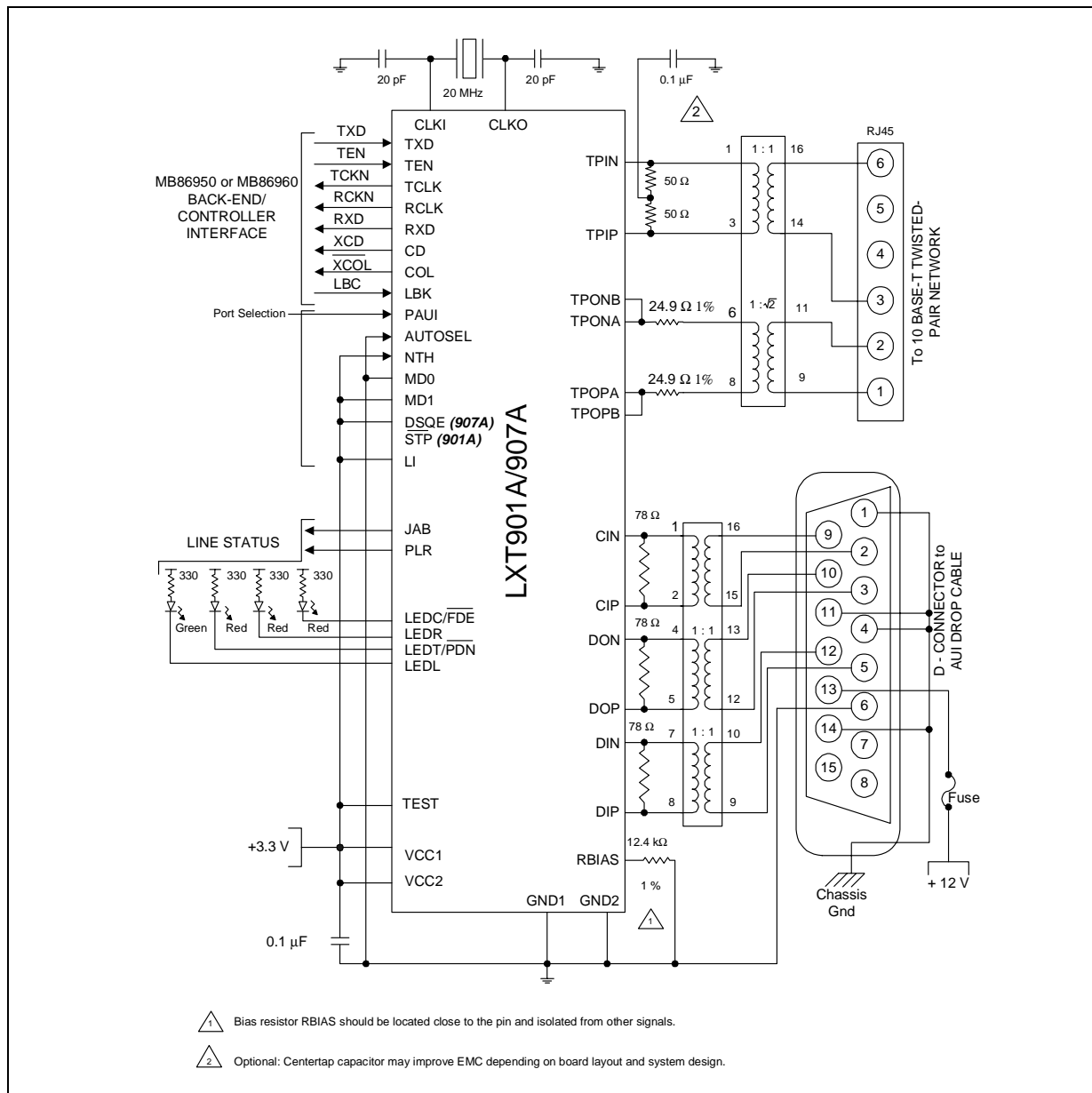
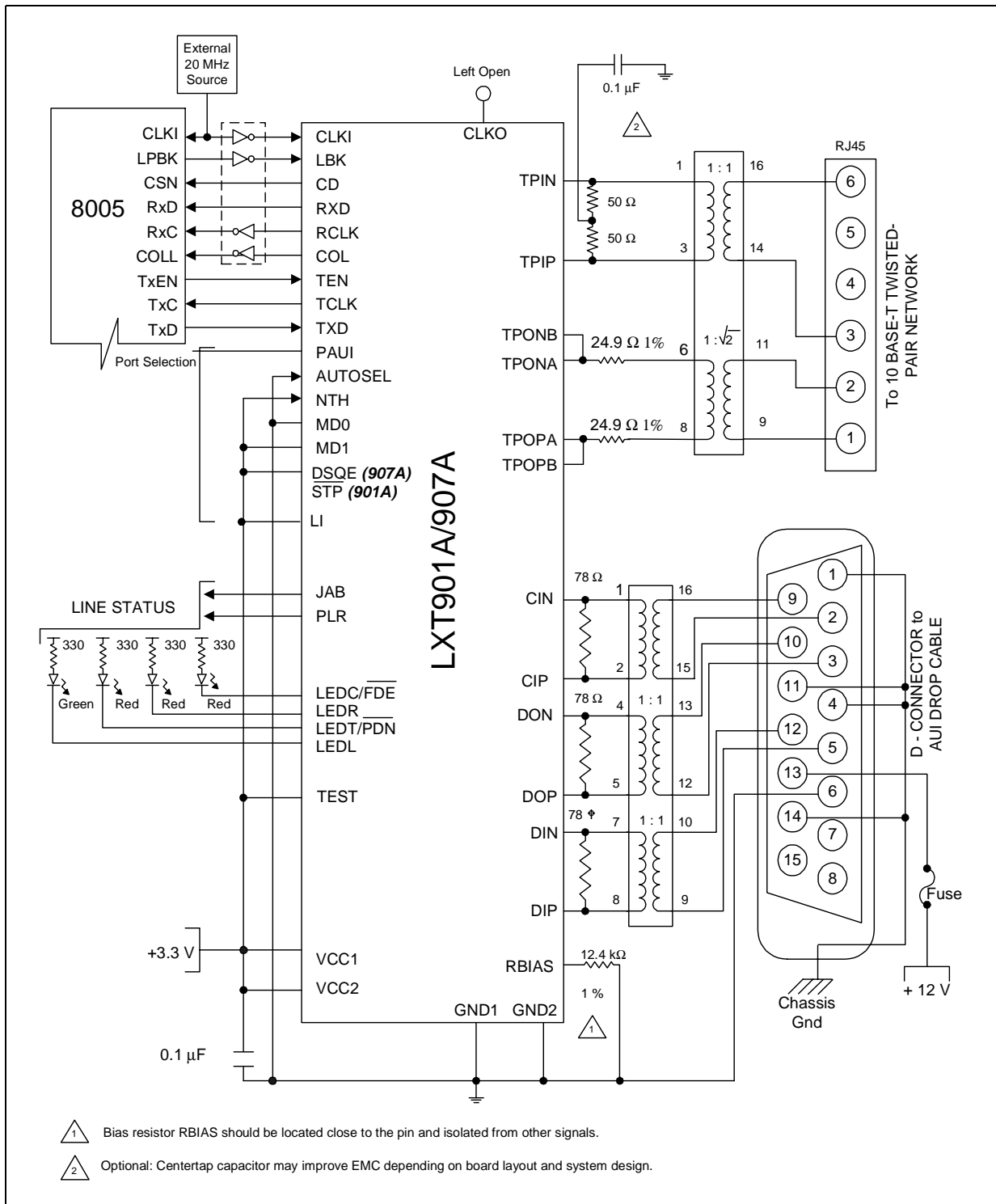

Figure 13. Manual Port Select with Seeq 8005 Controller



3.4.5 Three Media Application

Figure 14 shows the LXT907A in Mode 2 (compatible with Intel 82596 controllers) with additional media options for the AUI port. Two transformers are used to couple the AUI port to either a D-connector or a BNC connector. A DP8392 coax transceiver with PM6044 power supply are required to drive the thin coax network through the BNC.

Figure 14. Three Media Application

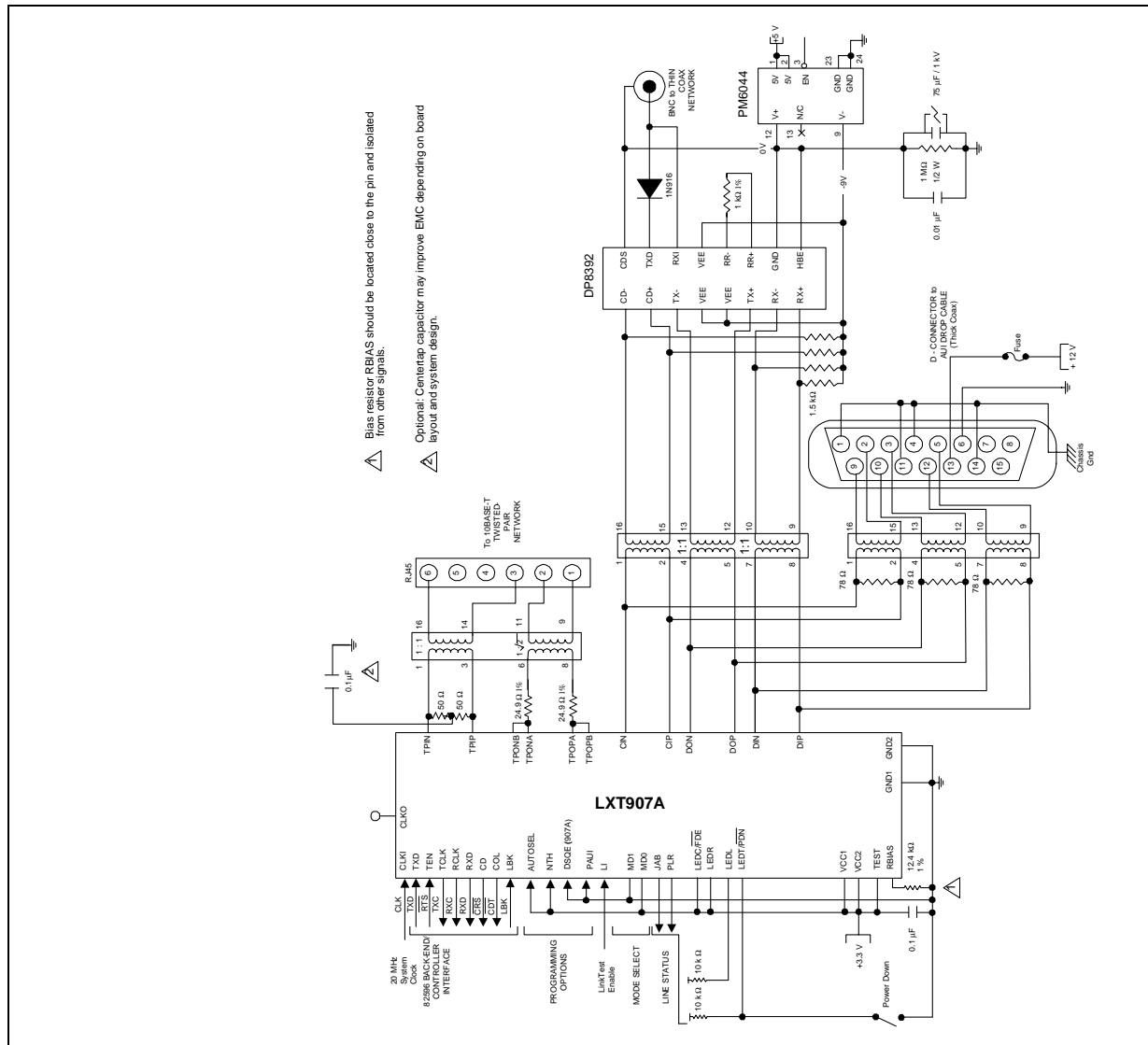

3.4.6 AUI Encoder/Decoder Only

In this application (Figure 15), the DTE is connected to a coaxial network through the AUI. AUTOSEL is tied Low and PAUI is tied High to manually select the AUI port. The twisted-pair port is not used. With MD1 and MD0 both Low, the logic and framing are set to Mode 1 (compatible with AMD AM7990 controllers). The LI pin is tied Low, disabling the link test function. The DSQE pin is also Low, enabling the SQE function on the LXT907A. The LBK input controls loopback. A 20 MHz system clock is supplied at CLK1, with CLK0 left open.

Figure 15. AUI Encoder/Decoder Only Application

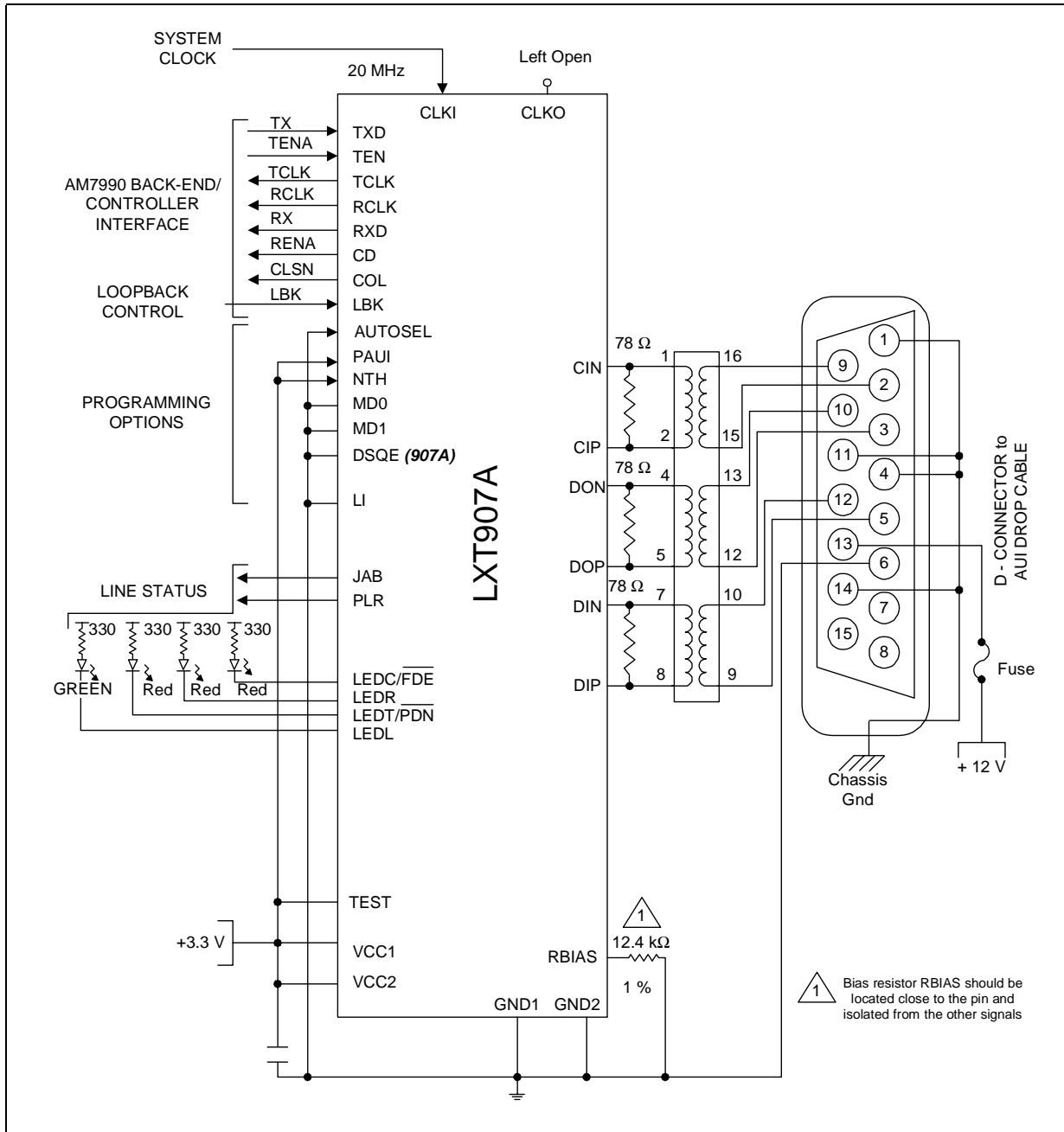

3.4.7 150Ω Shielded Twisted-Pair Only (LXT901A only)

Figure 16 shows the LXT901A in a typical twisted-pair only application. The DTE is connected to a 10BASE-T network through the twisted-pair RJ-45 connector. Note that the AUI port is not used. With MD0 tied High and MD1 Low, the LXT901A logic and framing are set to Mode 2 (compatible with Intel 82596 controllers).

A 20 MHz system clock input at CLK1 is used in place of the crystal oscillator. (CLK0 is left open). The L1 pin externally controls the link test function. The STP and NTH pins are both tied Low, selecting the reduced receiver threshold and 150 Ω termination for shielded twisted-pair cable. The switch at LEDT/PDN manually controls the power down mode.

Figure 16. 150 Ω Shielded Twisted-Pair Only Application (LXT901A)

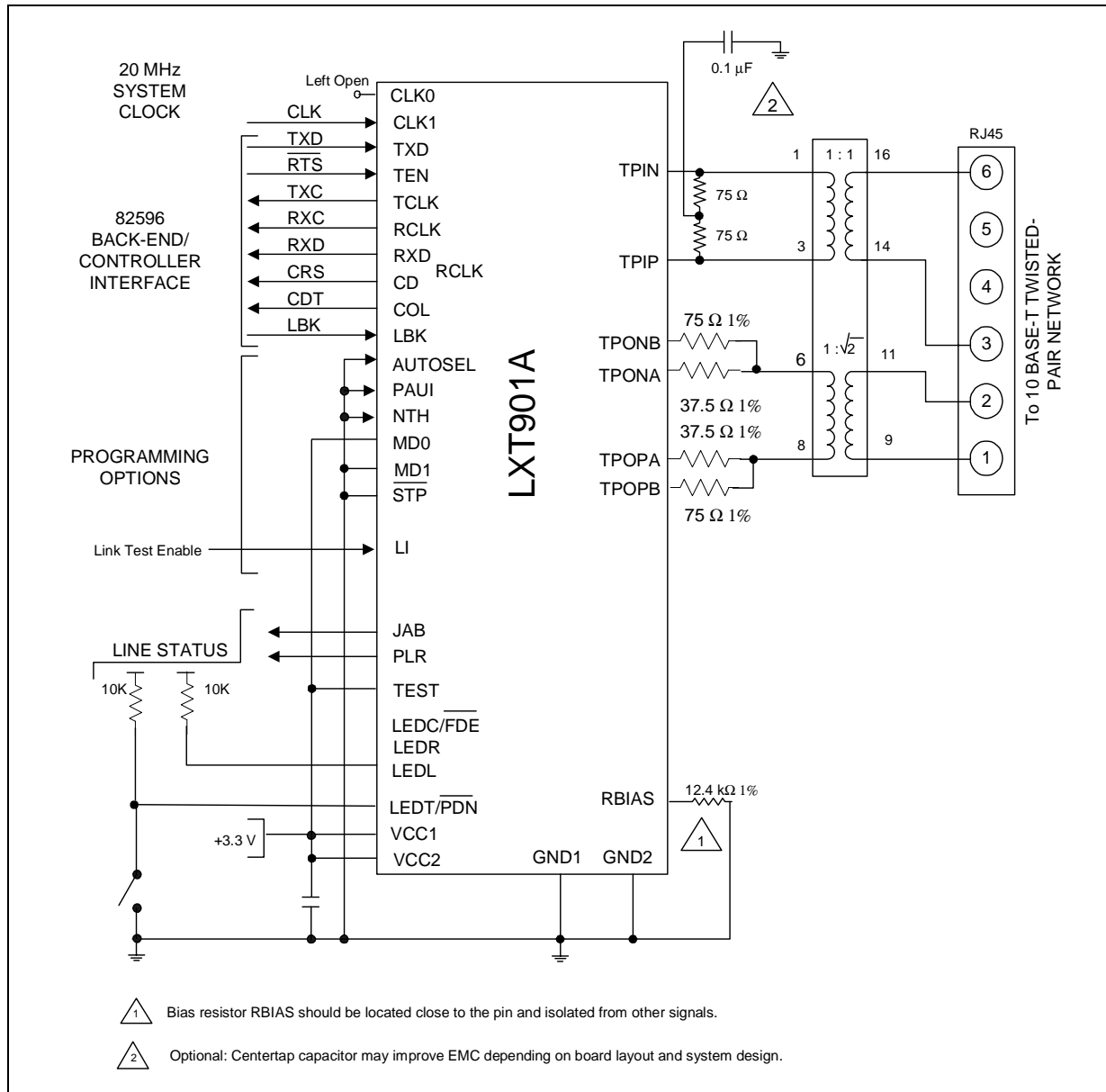

4.0 Test Specifications

Note: Table 4 through Table 13 and Figure 17 through Figure 42 represent the performance specifications of the LXT901A/907A. These specifications are guaranteed by test except where noted “by design.” Minimum and maximum values listed in Table 6 through Table 13 apply over the recommended operating conditions specified in Table 5.

For all Quality and Reliability issues (for example, parts packaging and thermal specifications), please send your questions to Intel at the following e-mail address: qr.requests@intel.com.

Table 4. Absolute Maximum Values

Parameter	Symbol	Min	Max	Units
Supply voltage	VCC	-0.3	6	V
Storage temperature	TSTG	-65	+150	°C
Caution: Exceeding these values may cause permanent damage. Functional operation under these conditions is not implied. Exposure to maximum rating conditions for extended periods may affect device reliability.				

Table 5. Recommended Operating Conditions

Parameter	Symbol	Min	Typ	Max	Units
Recommended supply voltage ¹	VCC	3.13	3.3	3.47	V
Recommended operating temperature (Commercial)	TOP	0	–	+70	°C
1. Voltages with respect to ground unless otherwise specified. Power supply should be filtered to suppress high frequency transients, consistent with good PCB design.					

Table 6. I/O Electrical Characteristics

Parameter	Sym	Min	Typ ¹	Max	Units	Test Conditions
Input Low voltage ²	VIL	–	–	0.8	V	–
Input High voltage ²	VIH	2.0	–	–	V	–
Output Low voltage	VoL	–	–	0.4	V	IoL = 1.6 mA
	VoL	–	–	10	%VCC	IoL < 10 µA
Output Low voltage (Open drain LED driver)	VoLL	–	–	0.7	%VCC	IoLL = 10 mA
Output High voltage	VoH	2.4	–	–	V	IoH = 40 µA
	VoH	90	–	–	%VCC	IoH < 10 µA
Output rise time	CMOS	–	–	7	ns	CLOAD = 20 pF
TCLK & RCLK	TTL	–	–	7	ns	–
1. Typical values are at 25°C and are for design aid only, are not guaranteed, and are not subject to production testing. 2. Limited functional tests are performed at these input levels. The majority of functional tests are performed at levels of 0V and 3V.						

Table 6. I/O Electrical Characteristics (Continued)

Parameter		Sym	Min	Typ ¹	Max	Units	Test Conditions
Output fall time TCLK & RCLK	CMOS	–	–	7	12	ns	CLOAD= 20 pF
	TTL	–	–	7	8	ns	–
CLKI rise time (externally driven)		–	–	–	10	ns	–
CLKI duty cycle (externally driven)		–	–	–	40/60	%	–
Supply current	Normal Mode	I _{CC}	–	65	85	mA	Idle Mode
		I _{CC}	–	95	120	mA	Transmitting on TP
		I _{CC}	–	95	120	mA	Transmitting on AUI
	Power Down Mode	I _{CC}	–	0.03	2	mA	–
<p>1. Typical values are at 25°C and are for design aid only, are not guaranteed, and are not subject to production testing.</p> <p>2. Limited functional tests are performed at these input levels. The majority of functional tests are performed at levels of 0V and 3V.</p>							

Table 7. AUI Electrical Characteristics

Parameter	Symbol	Min	Typ ¹	Max	Units	Test Conditions
Input Low current	I _{IL}	–	–	-700	μA	–
Input High current	I _{IH}	–	–	500	μA	–
Differential output voltage	V _{OD}	±550	–	±1200	mV	–
Differential squelch threshold	V _{DS}	150	250	350	mV	5 MHz square wave input
<p>1. Typical values are at 25°C and are for design aid only, are not guaranteed, and are not subject to production testing.</p>						

Table 8. TP Electrical Characteristics

Parameter	Symbol	Min	Typ ¹	Max	Units	Test Conditions
Transmit output impedance	Z _{OUT}	–	5	–	Ω	–
Transmit timing jitter addition ²	–	–	±3.3	±10	ns	0 line length for internal MAU
Transmit timing jitter added by the MAU and PLS sections ^{2,3}	–	–	±3.3	±5.5	ns	After line model specified by IEEE 802.3 for 10BASE-T internal MAU
<p>1. Typical values are at 25°C and are for design aid only, are not guaranteed, and are not subject to production testing.</p> <p>2. Parameter is guaranteed by design; not subject to production testing.</p> <p>3. IEEE 802.3 specifies maximum jitter additions at 1.5 ns for the AUI cable, 0.5 ns from the encoder, and 3.5 ns from the MAU.</p>						

Table 8. TP Electrical Characteristics (Continued)

Parameter		Symbol	Min	Typ ¹	Max	Units	Test Conditions
Receive input impedance		Z _{IN}	–	20	–	kΩ	Between TPIP/TPIN, CIP/CIN & DIP/DIN
Differential squelch Threshold	Normal threshold; NTH = 1	V _{DS}	300	400	585	mV	5 MHz square wave input
	Reduced threshold; NTH = 0	V _{DS}	180	250	345	mV	5 MHz square wave input

1. Typical values are at 25°C and are for design aid only, are not guaranteed, and are not subject to production testing.
2. Parameter is guaranteed by design; not subject to production testing.
3. IEEE 802.3 specifies maximum jitter additions at 1.5 ns for the AUI cable, 0.5 ns from the encoder, and 3.5 ns from the MAU.

Table 9. Switching Characteristics

Parameter		Symbol	Minimum	Typical ¹	Maximum	Units
Jabber Timing	Maximum transmit time	–	20	–	150	ms
	Unjab time	–	250	–	750	ms
Link Integrity Timing	Time link loss receive	–	50	–	150	ms
	Link min receive	–	2	–	7	ms
	Link max receive	–	50	–	150	ms
	Link transmit period	–	8	10	24	ms

1. Typical values are at 25°C and are for design aid only, are not guaranteed, and are not subject to production testing.

Table 10. RCLK/Start-of-Frame Timing

Parameter		Symbol	Minimum	Typical ¹	Maximum	Units
Decoder acquisition time	AUI	t _{DATA}	–	900	1100	ns
	TP	t _{DATA}	–	1200	1500	ns
CD turn-on delay	AUI	t _{CD}	–	25	200	ns
	TP	t _{CD}	–	425	550	ns
Receive data setup from RCLK	Mode 1	t _{RDS}	60	70	–	ns
	Modes 2, 3 and 4	t _{RDS}	30	45	–	ns
Receive data hold from RCLK	Mode 1	t _{RDH}	10	20	–	ns
	Modes 2, 3 and 4	t _{RDH}	30	45	–	ns
RCLK shut off delay from CD assert (LXT907A only; Mode 3)		t _{sws}	–	±100	–	ns

1. Typical values are at 25°C and are for design aid only, are not guaranteed, and are not subject to production testing.

Table 11. RCLK/End-of-Frame Timing

Parameter	Type	Sym	Mode 1	Mode 2	Mode 3	Mode 4	Units
RCLK after CD off	Min	tRC	5	1	27	5	BT
Rcv data throughput delay	Max	tRD	400	375	375	375	ns
CD turn off delay ²	Max	tCDOFF	500	475	475	475	ns
Receive block out after TEN off	Typ ¹	tIFG	5	50	–	–	BT
RCLK switching delay after CD off (LXT907A only; Mode 3)	Typ ¹	tSWE	–	–	120(±80)	–	ns

1. Typical values are at 25°C and are for design aid only, are not guaranteed, and are not subject to production testing.
2. CD turn-off delay measured from middle of last bit: timing specification is unaffected by the value of the last bit.

Table 12. Transmit Timing

Parameter	Symbol	Minimum	Typical ¹	Maximum	Units
TEN setup from TCLK	tEHCH	22	–	–	ns
TXD setup from TCLK	tDSCH	22	–	–	ns
TEN hold after TCLK	tCHEL	5	–	–	ns
TXD hold after TCLK	tCHDU	5	–	–	ns
Transmit start-up delay - AUI	tSTUD	–	220	450	ns
Transmit start-up delay - TP	tSTUD	–	430	450	ns
Transmit through-put delay - AUI	tTPD	–	–	300	ns
Transmit through-put delay - TP	tTPD	–	300	350	ns

1. Typical values are at 25°C and are for design aid only, are not guaranteed, and are not subject to production testing.

Table 13. Collision, COL/CI Output and Loopback Timing

Parameter	Symbol	Minimum	Typical ¹	Maximum	Units
COL turn-on delay	tCOLD	–	40	500	ns
COL turn-off delay	tCOLOFF	–	420	500	ns
COL (SQE) Delay after TEN off	tSQED	0.65	1.2	1.6	µs
COL (SQE) Pulse Duration	tSQEP	500	1000	1500	ns
LBK setup from TEN	tKHEH	10	25	–	ns
LBK hold after TEN	tKHEL	10	0	–	ns

1. Typical values are at 25°C and are for design aid only, are not guaranteed, and are not subject to production testing.

4.1 Timing Diagrams for Mode 1 (MD1 = Low, MD0 = Low) Figures 17 - 22

Figure 17. Mode 1 RCLK/Start-of-Frame Timing

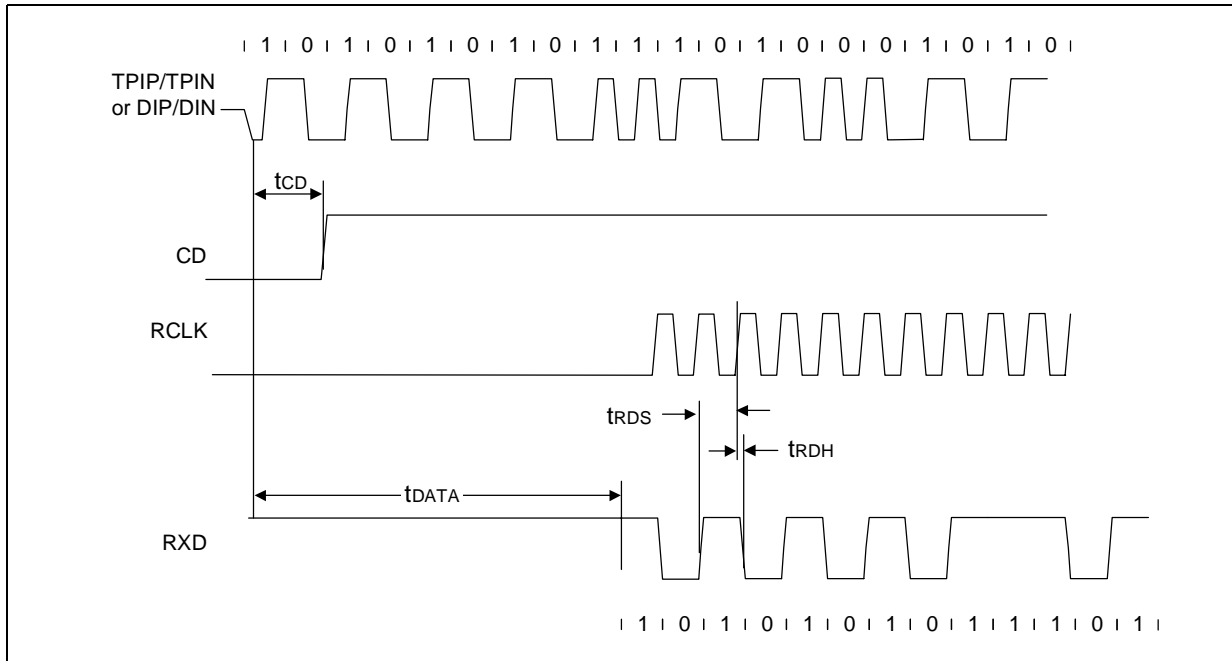

Figure 18. Mode 1 RCLK/End-of-Frame Timing

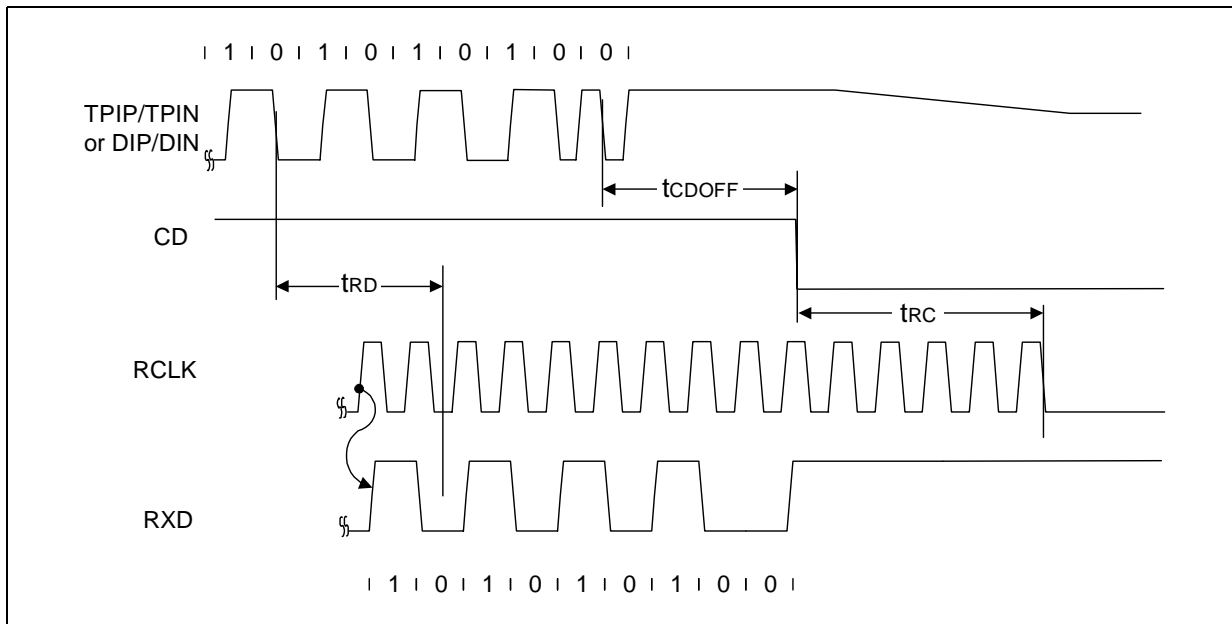

Figure 19. Mode 1 Transmit Timing

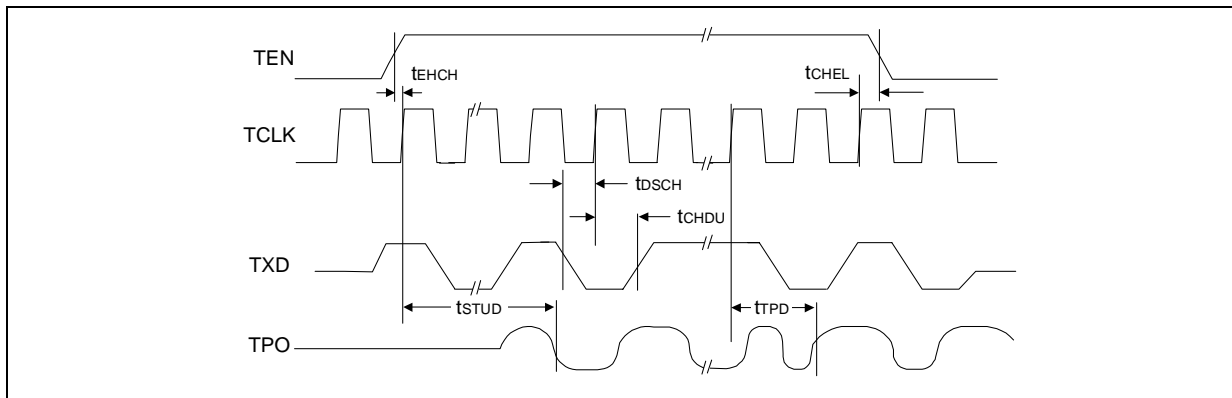

Figure 20. Mode 1 Collision Detect Timing

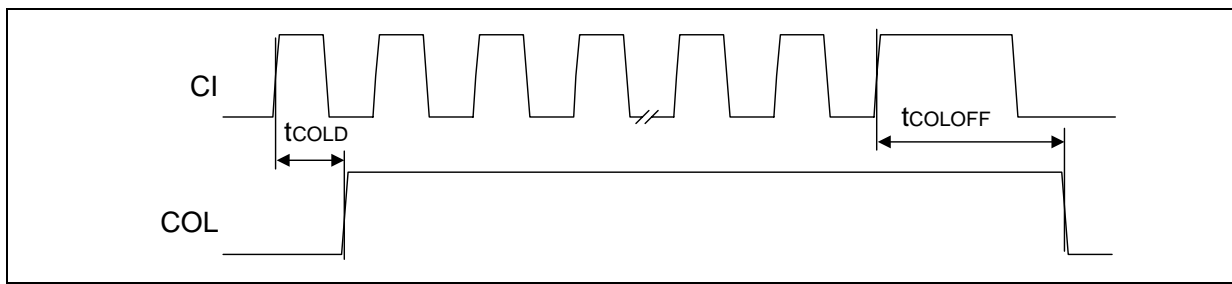

Figure 21. Mode 1 COL/CI Output Timing

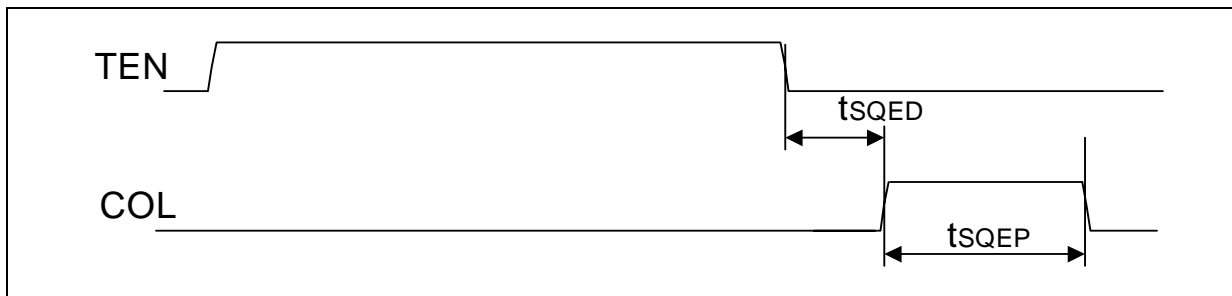
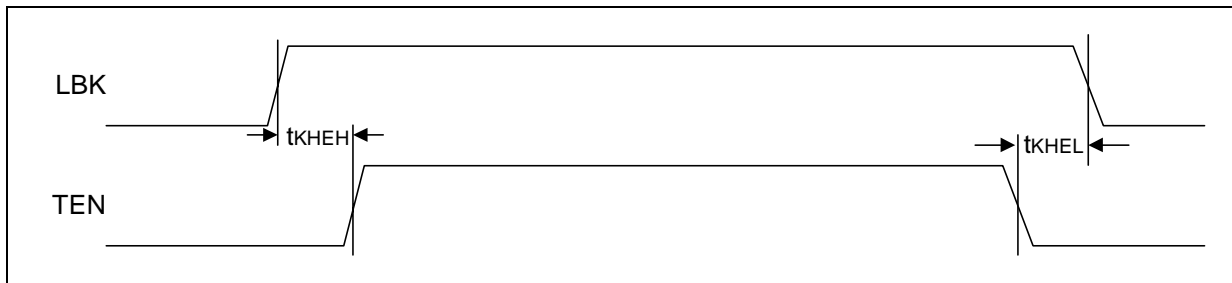

Figure 22. Mode 1 Loopback Timing



4.2 Timing Diagrams for Mode 2 (MD1 = Low, MD0 = High) Figures 23 - 28

Figure 23. Mode 2 RCLK/Start-of-Frame Timing

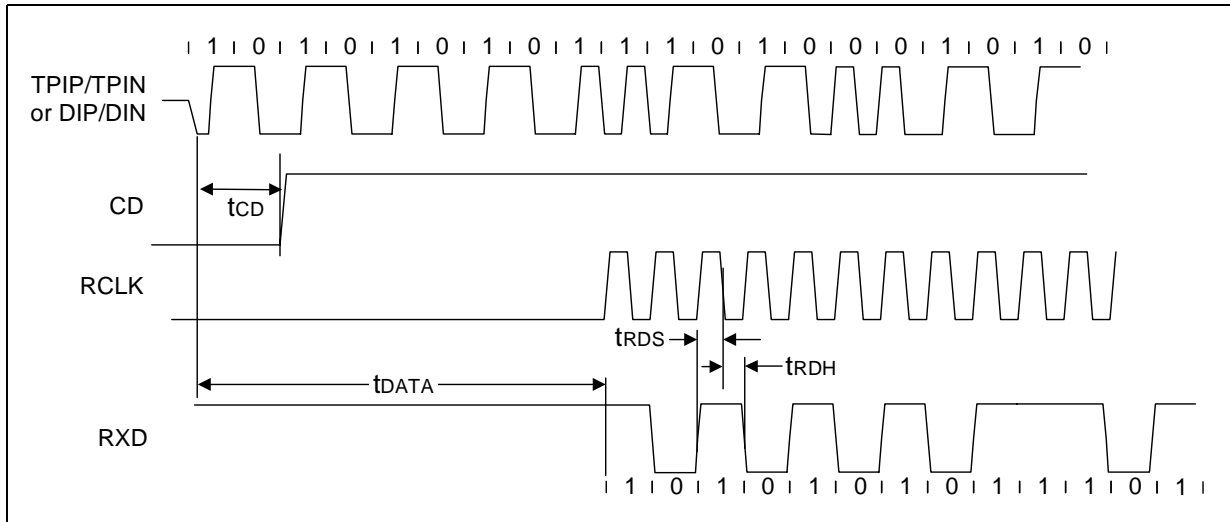

Figure 24. Mode 2 RCLK/End-of-Frame Timing

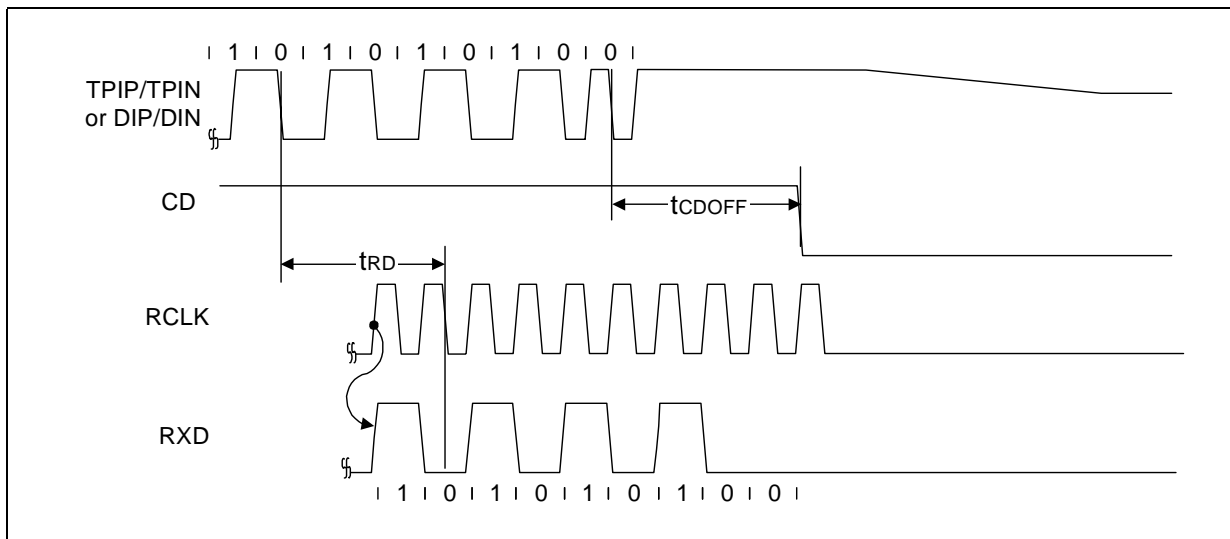

Figure 25. Mode 2 Transmit Timing

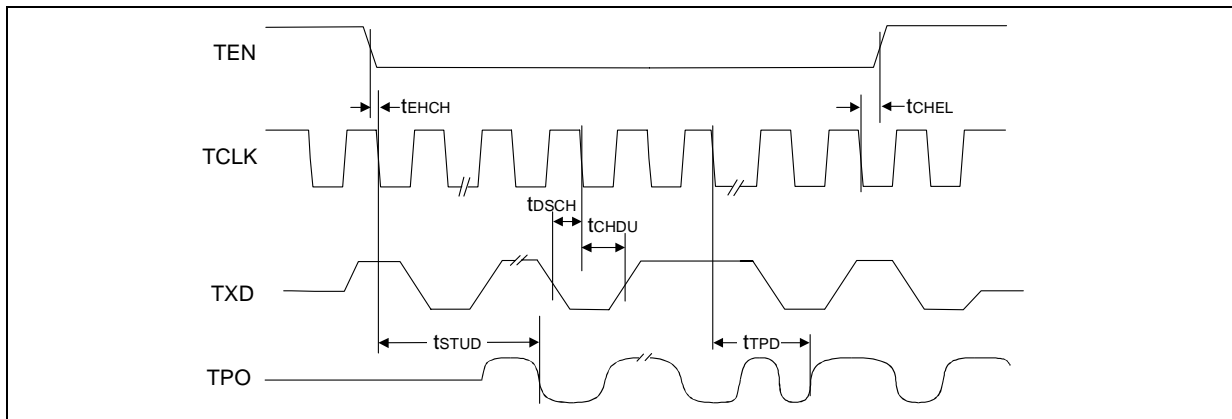

Figure 26. Mode 2 Collision Detect Timing

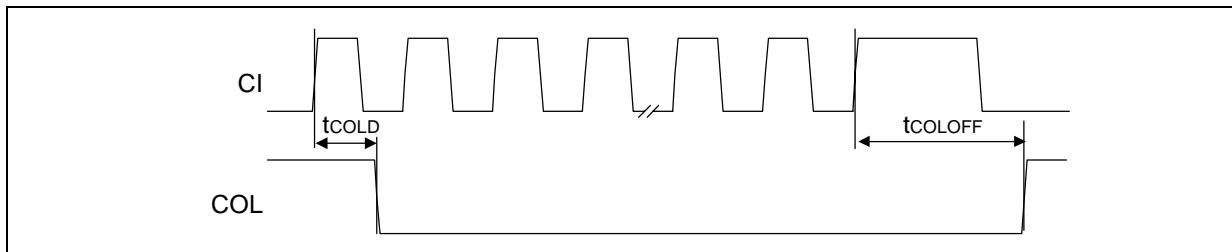

Figure 27. Mode 2 COL/CI Output Timing

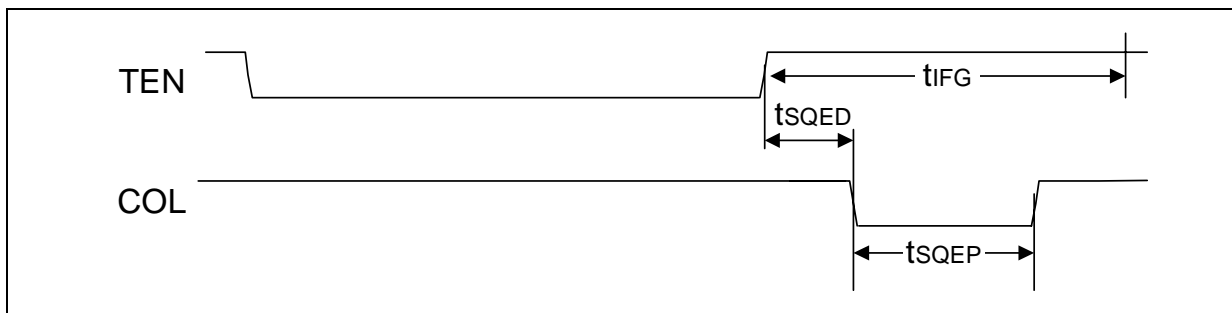
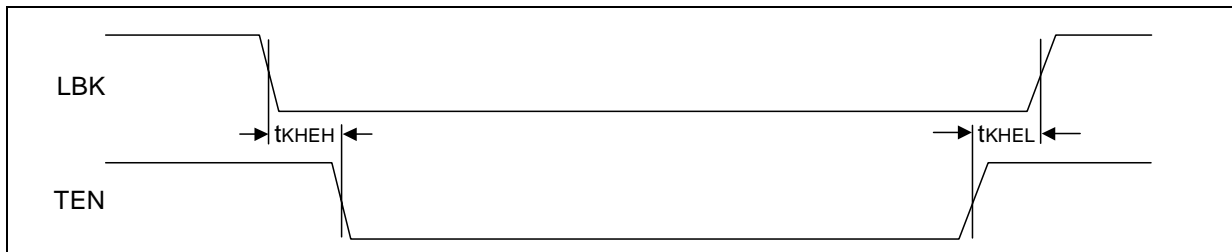

Figure 28. Mode 2 Loopback Timing



4.3 Timing Diagrams for Mode 3 (MD1 = High, MD0 = Low) Figures 29 - 36

Figure 29. Mode 3 RCLK/Start-of-Frame Timing (LXT901A)

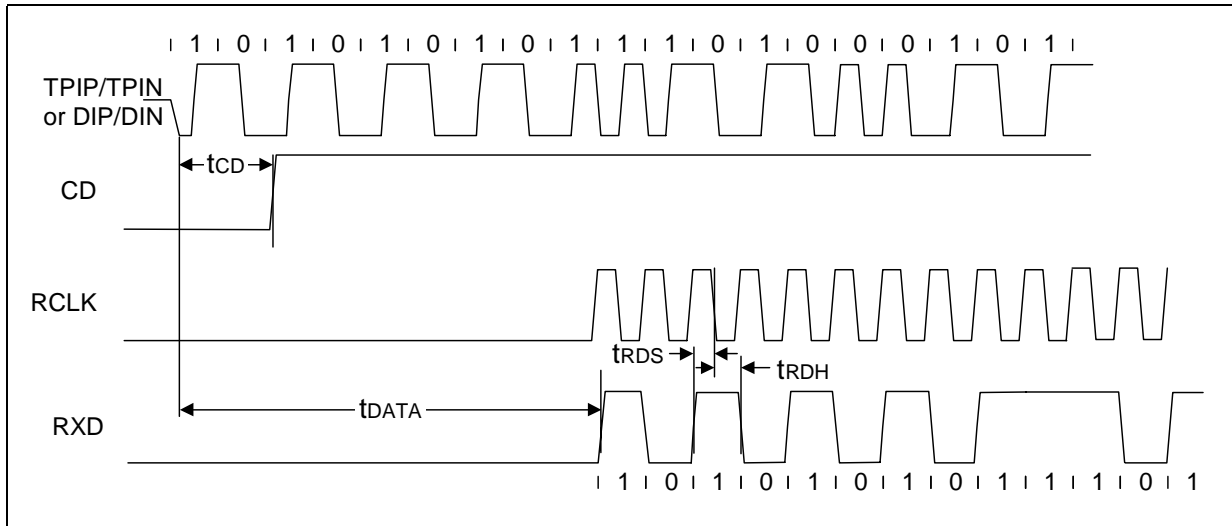

Figure 30. Mode 3 RCLK/End-of-Frame Timing (LXT901A)

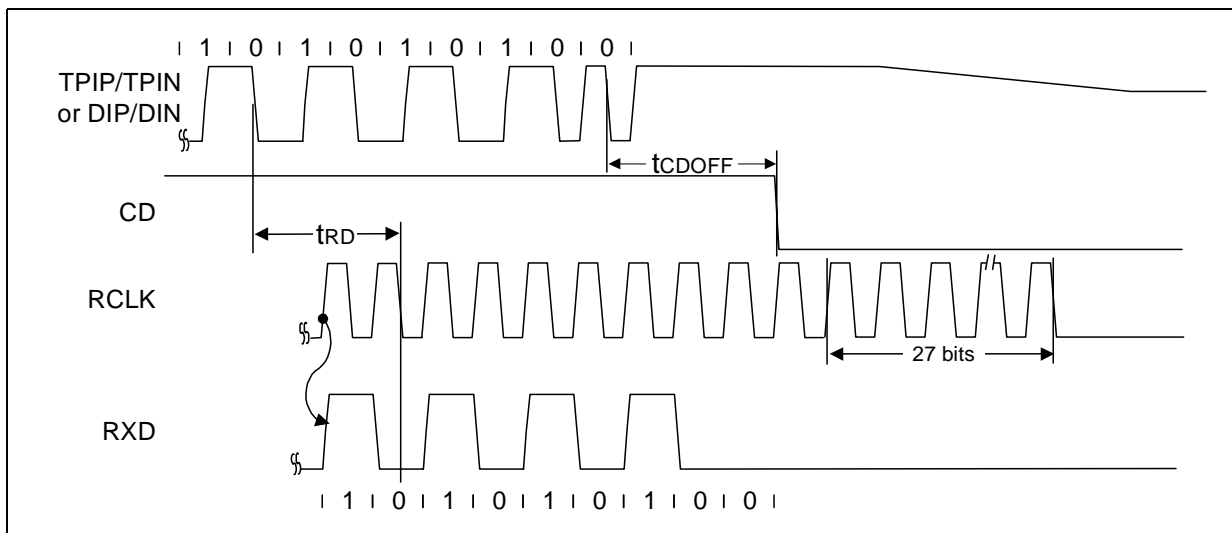

Figure 31. Mode 3 RCLK/Start-of-Frame Timing (LXT907A)

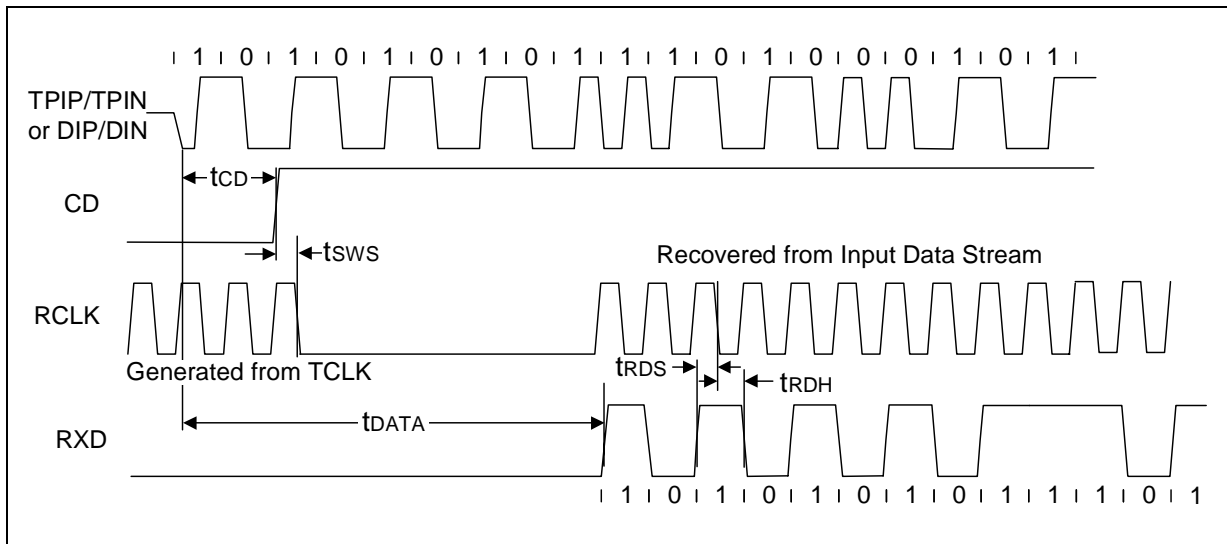

Figure 32. Mode 3 RCLK/End-of-Frame Timing (LXT907A)

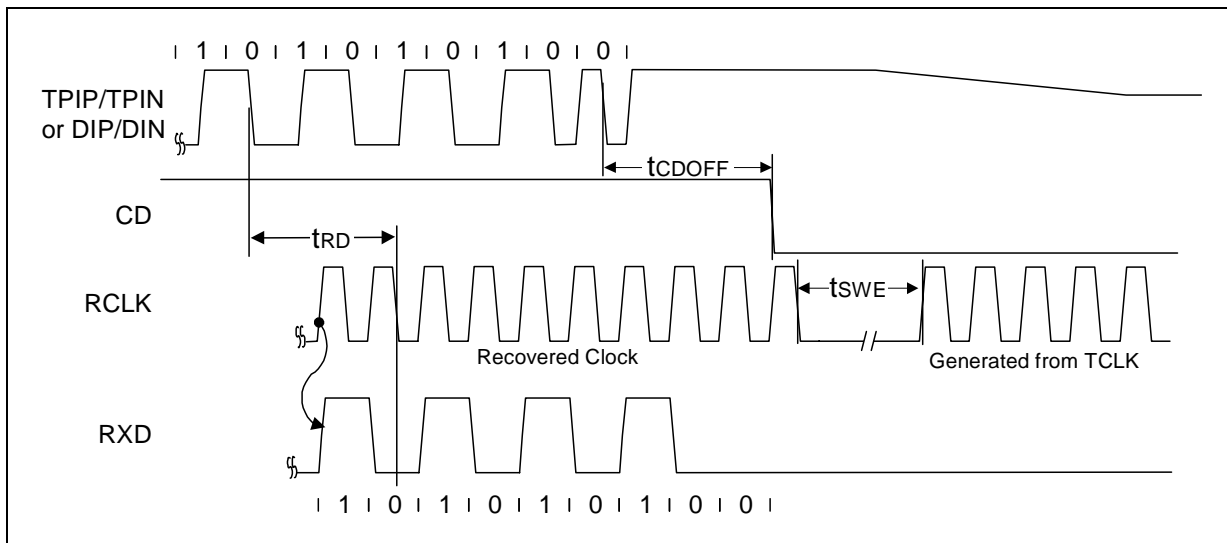

Figure 33. Mode 3 Transmit Timing

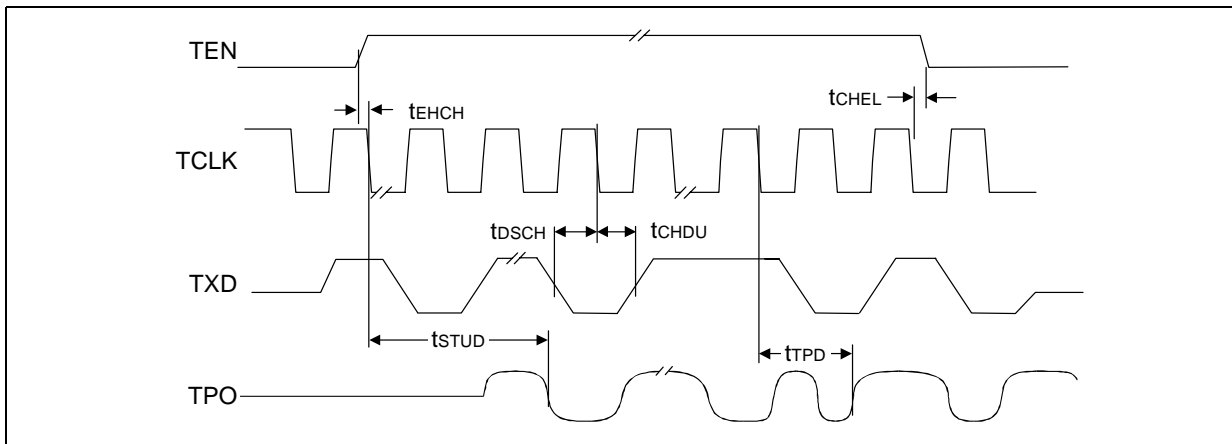

Figure 34. Mode 3 Collision Detect Timing

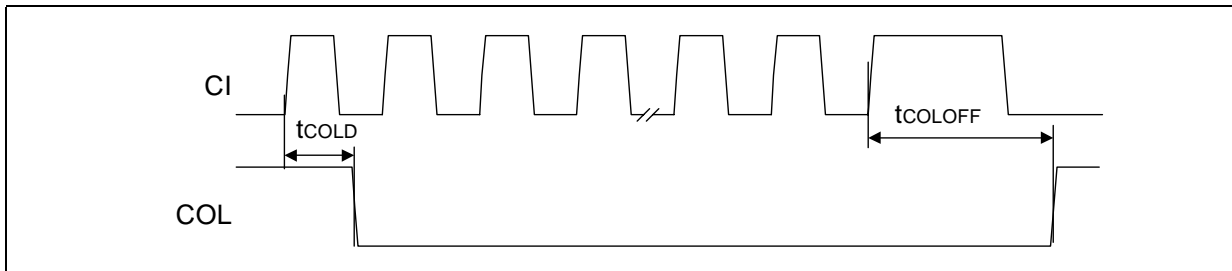

Figure 35. Mode 3 COL/CI Output Timing

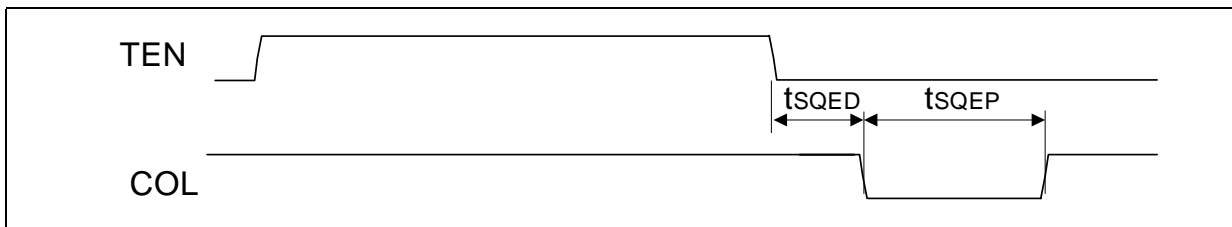
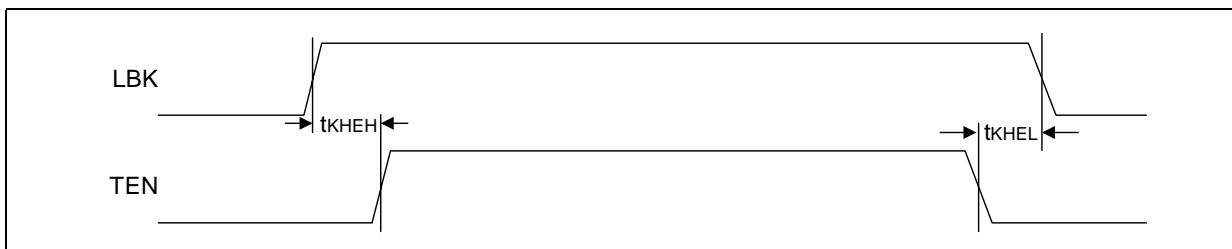

Figure 36. Mode 3 Loopback Timing



4.4 Timing Diagrams for Mode 4 (MD1 = High, MD0 = High) Figures 37 - 42

Figure 37. Mode 4 RCLK/Start-of-Frame Timing

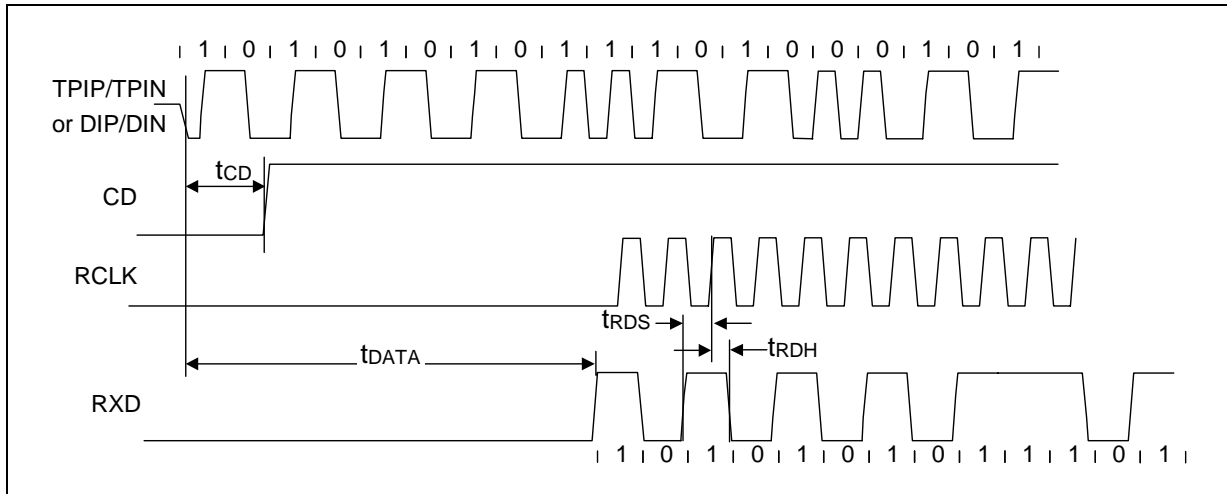

Figure 38. Mode 4 RCLK/End-of-Frame Timing

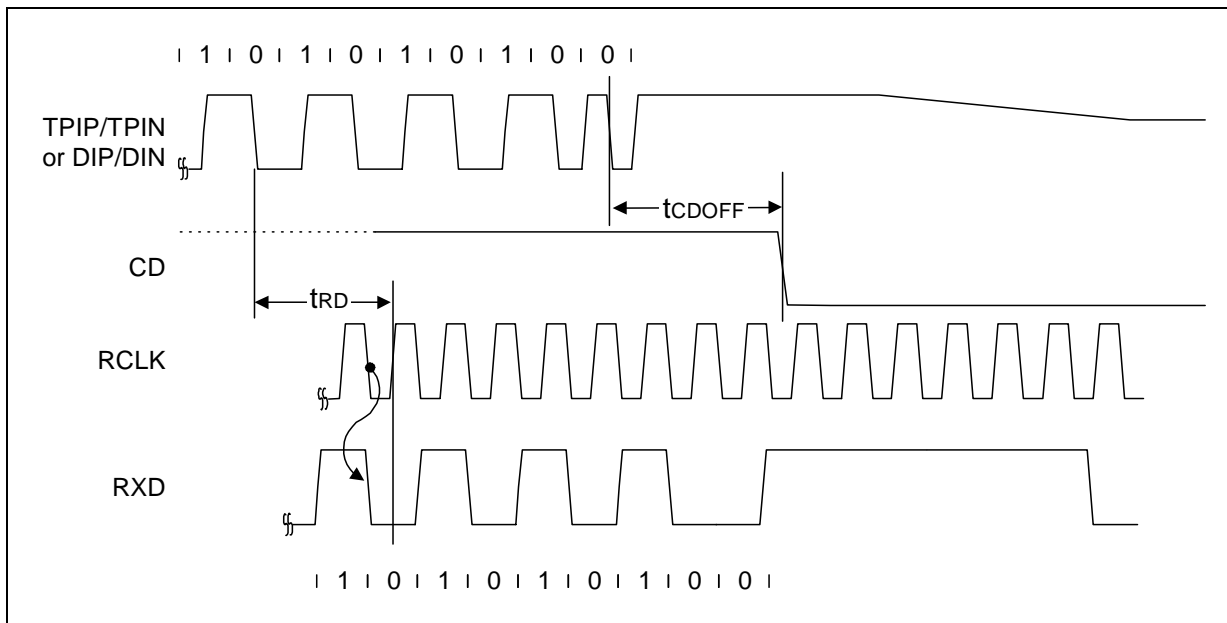

Figure 39. Mode 4 Transmit Timing

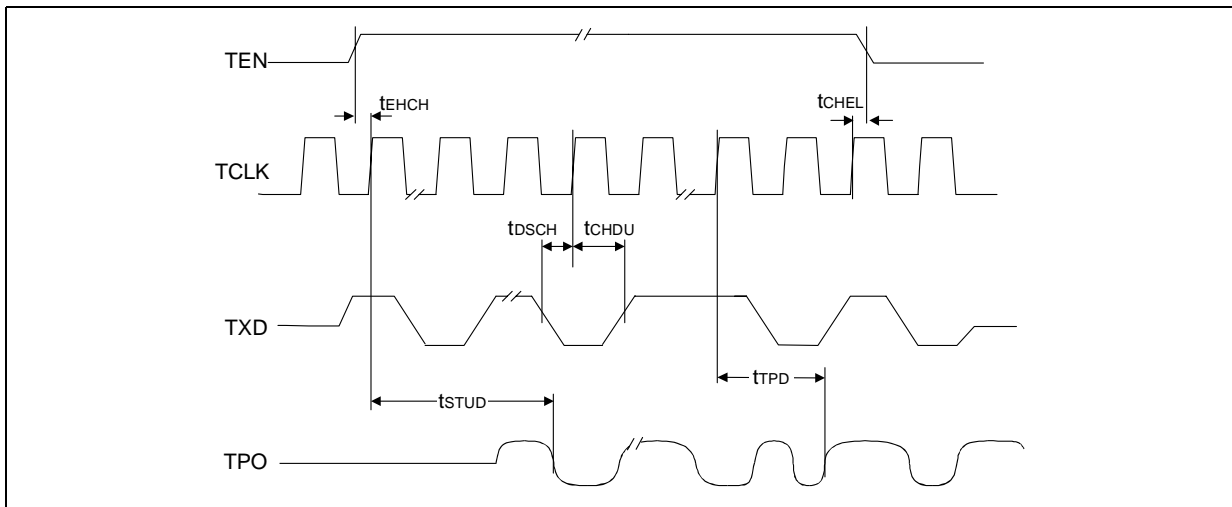

Figure 40. Mode 4 Collision Detect Timing

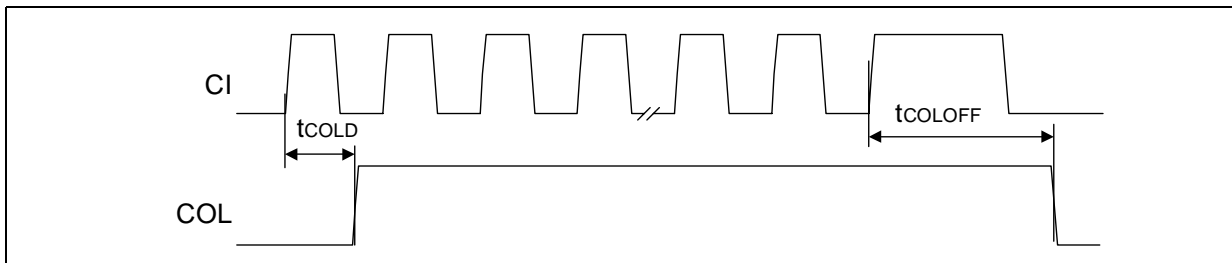

Figure 41. Mode 4 COL/CI Output Timing

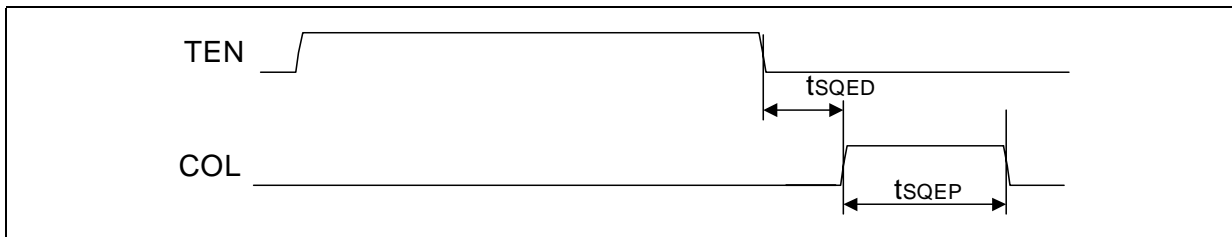
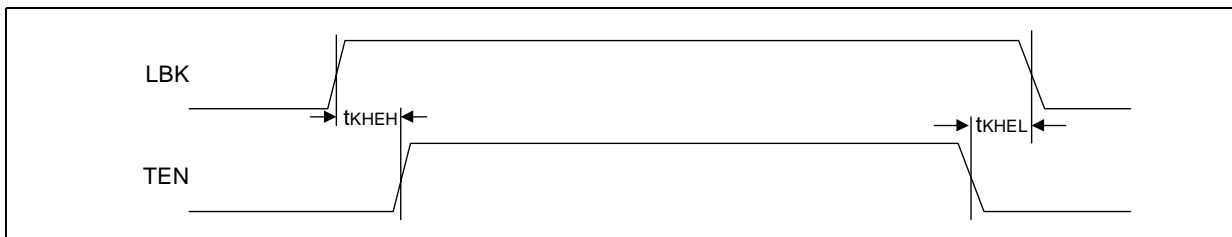

Figure 42. Mode 4 Loopback Timing



5.0 Mechanical Specifications

Figure 43. 44-Pin PLCC

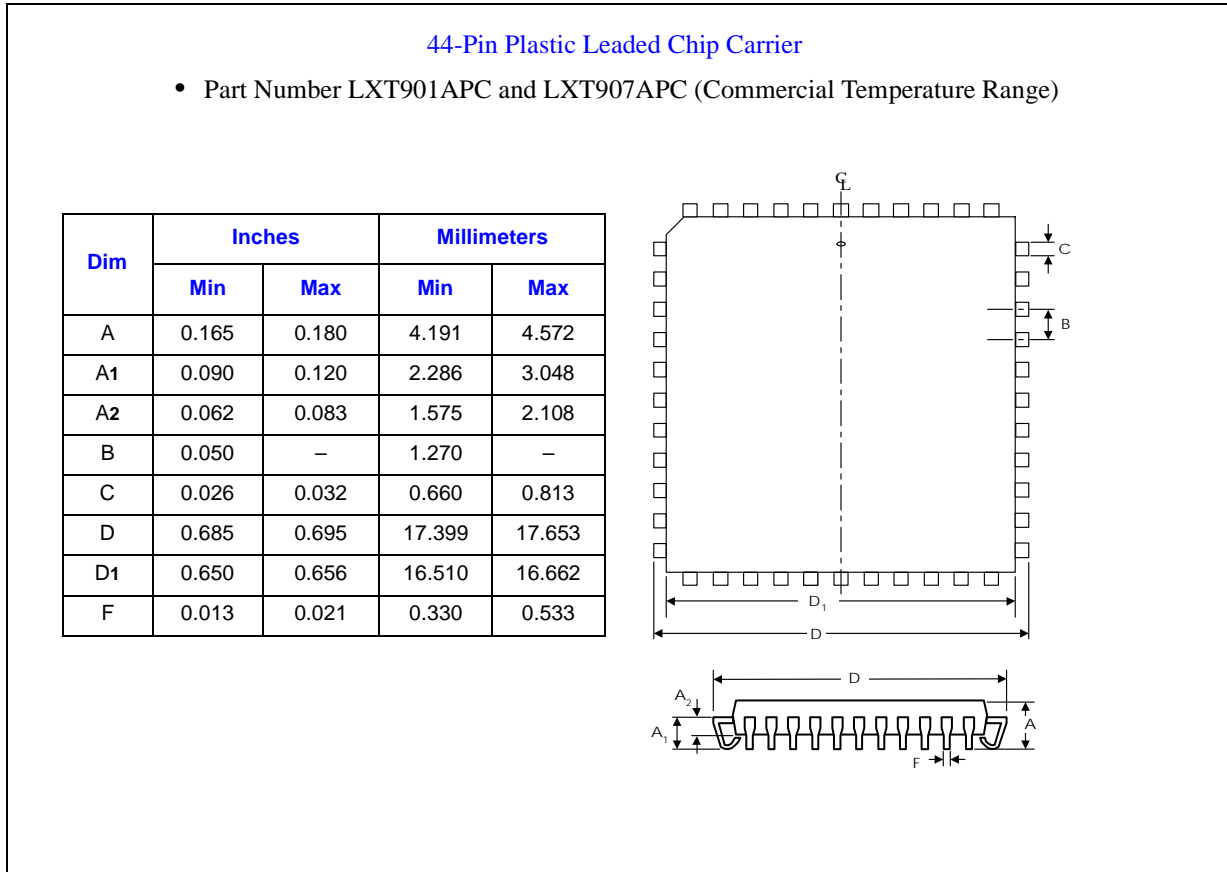
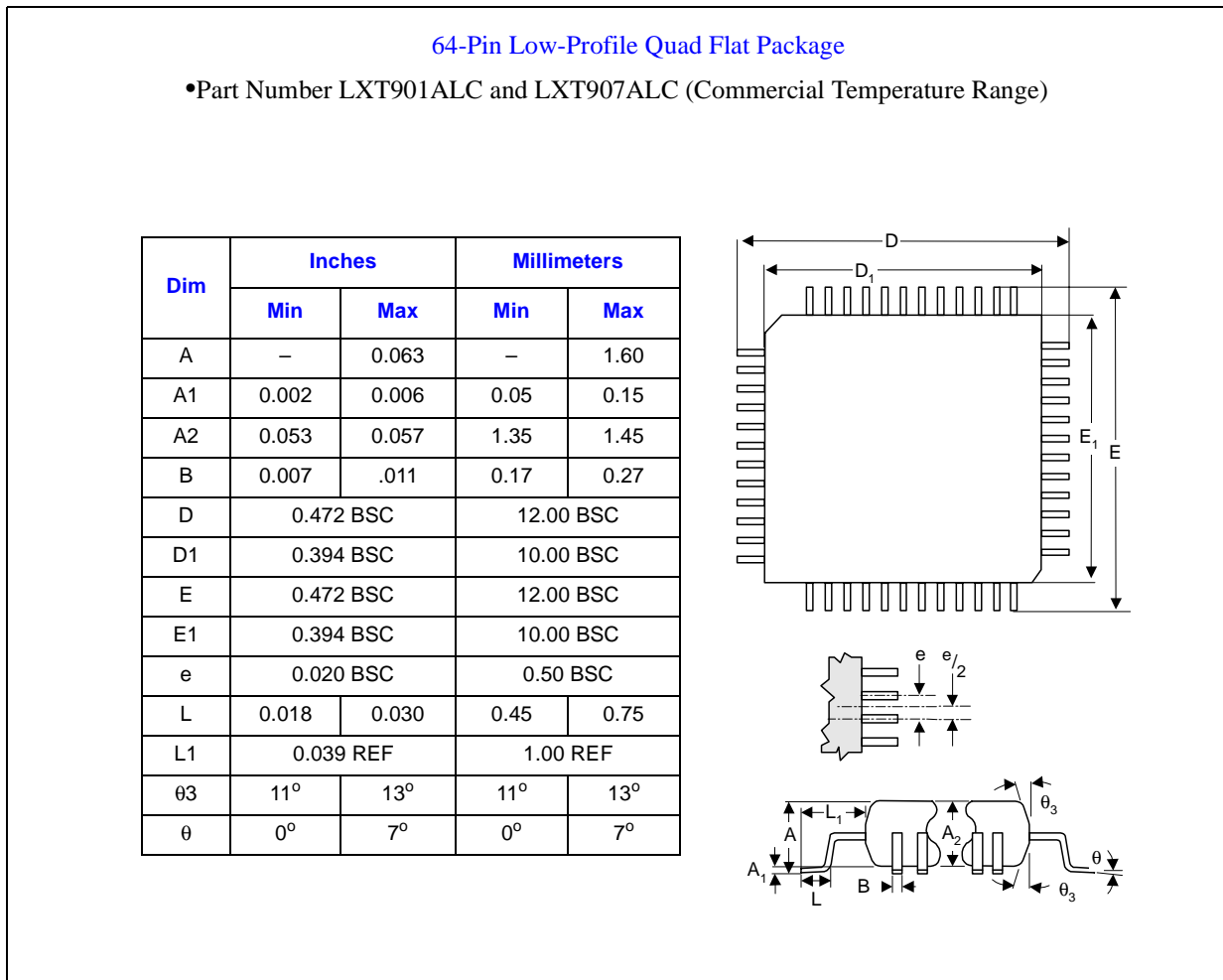

Figure 44. 64-Pin LQFP



Appendix A Ordering Information

Table 14. Product Information

Number	Revision	Qualification	Tray MM	Tape & Reel MM
DJLXT901ALC.A4	A4	S	831684	831801
DJLXT907ALC.A4	A4	S	831647	831806
NLXT901APC.A4	A4	S	831653	831811
NLXT907APC.A4	A4	S	831664	831820

Figure 45. Ordering Information - Sample

