

NOTES: UNLESS OTHERWISE SPECIFIED

1. MATERIAL SPECIFICATIONS:  
BRASS PER ASTM B16
2. FINISH SPECIFICATIONS:  
0.000030 MIN. GOLD PER SAE-AMS2422 OVER  
0.000080 MIN. NICKEL PER SAE-AMS-QQ-N-290
3. FOR USE WITH 12 GA. EVERTOP UL1015 WIRE.

REV	DESCRIPTION	BY DATE	APPD
00	PRELIMINARY DRAWING	LMD 3/6/06	XXX

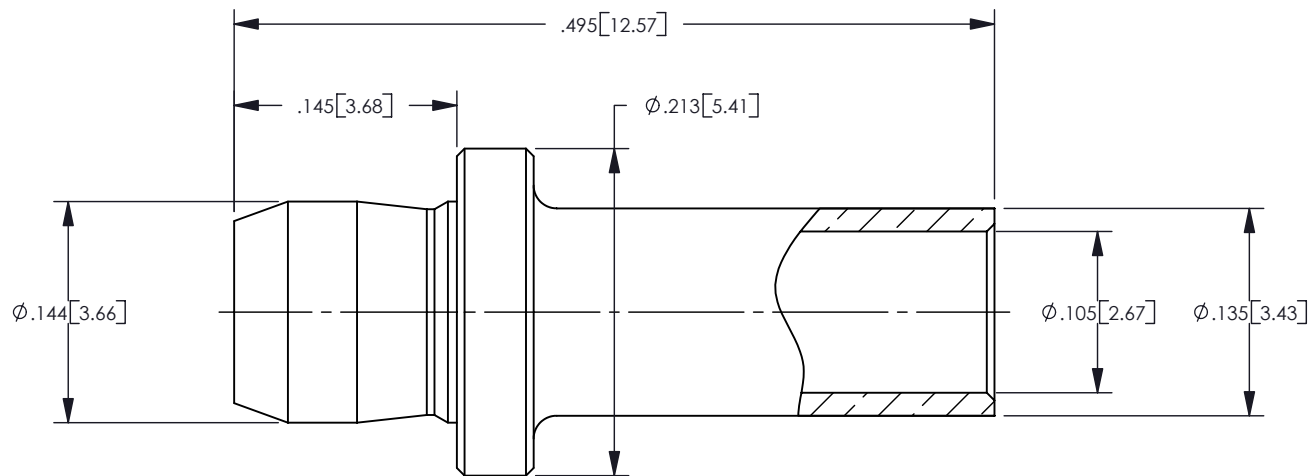
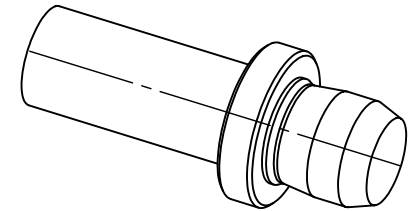

CATALOG P/N: 01383

PER ASME Y14.5M-1994  
UNLESS OTHERWISE SPECIFIED:  
DIMENSIONS ARE IN INCHES [MM]  
TOLERANCES:  
DECIMAL: .XX ± .01 [0.3]  
.XXX ± .005 [0.13]  
.XXXX ± .XXXX  
ANGLES: ± 2° SCALE: 8:1

**NORTHROP GRUMMAN**  
**Winchester Electronics** 62 Barnes Industrial Road North  
Wallingford, CT 06492

CUSTOMER DRAWING



STRAIGHT MALE  
CRIMP CONTACT

DRAWN	DATE	APPROVED	DATE
LMD	3/6/06	XXX	XX/XX/XX
APPROVED	DATE	APPROVED	DATE
XXX	XX/XX/XX	XXX	XX/XX/XX

<b>A</b>	SDSD01383	SHT 1 OF 1	REV 00
----------	-----------	------------	--------