

Features

- High Reliability
- Energy Efficient
- FCC Type Accepted
- High Channel Loading Capacity
- Easy to Install
- No Maintenance Required
- Office Battery Powered
- Cost Competitive
- 4, 6, 7, 8 and 11 GHz Bands

Description

Hewlett-Packard manufactures a complete line of solid state power amplifiers and retrofit accessory kits to replace TWTs and their associated power supplies in terrestrial point-to-point microwave radio transmitters. These full-band amplifiers are available with 10 watts output power at 4, 6, 7, 8 and 11 GHz. The 6 and 11 GHz units are available in two physical styles. Performance characteristics of both styles are identical. The single unit has the RF and DC/DC converter combined into a single package that is ideal for replacing the older style TWTs. The split unit separates the RF and DC/DC converter into two packages with the RF section having the same footprint as the high-efficiency TWT it replaces.

Cost Effective TWT Replacement

HP's solid state power amplifiers are a cost effective solution to TWT replacement. Solid state GaAs FET RF power amplifiers typically require less current than a TWT amplifier. This reduction in DC power consumption can increase the battery plant reserve time or allow additional equipment to be added without increasing battery capacity. Reduced power consumption can eliminate the need for increased rectifier re-charging capacity and larger emergency engine alternators. Less power dissipation means less heat is generated, thus the cost of air conditioning can be reduced. If obsolete power plants or air conditioning units are to be replaced, the new ones can be smaller and less costly.

The HP amplifier is directly competitive in initial price if any part of the TWT amplifier needs to be changed. Retrofit accessory packages include all hardware, transitions and instructions

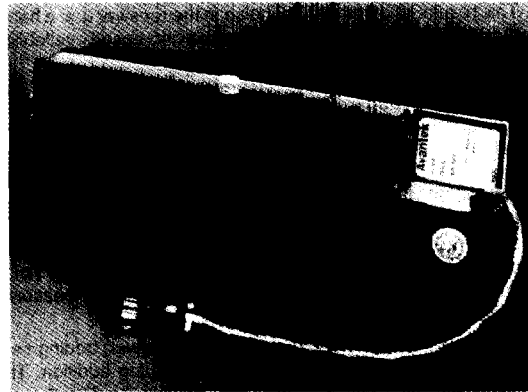
Power Amplifier (Single Unit)

needed to complete an amplifier retrofit installation in about one hour. Retrofit amplifiers are also equipped with an input attenuator capable of accepting any RF input power level between -1 and +10 dBm, thereby permitting installation of the TWT replacement amplifier without requiring adjustment to any of the previous stages. Additionally, these amplifiers can be used as spares for all of the various radio types that have been retrofitted.

Solid state amplifiers can dramatically reduce maintenance costs. All TWT amplifiers have to be realigned periodically to correct for aging. Older tubes need adjustment three to four times per year. When these tubes are replaced with the HP solid state amplifier, no periodic alignment is required. Once the power amplifier output is set by adjusting the attenuator and the unit is placed into service, only the required FCC checks must be made. Since the HP IMFET™ internally-matched GaAs field effect transistors, at ambient room temperature, operate at a 115°C channel temperature, the calculated device MTBF exceeds 30 years. With this reliability, significant cost savings through long life can be realized. However, in the unlikely event of failure of the IMFET™ device, the output stage is also designed to fail-soft, thus avoiding complete service outage.

Transmission Improvement

Many transmission improvements can result when traveling wave tube amplifiers are replaced with HP solid state power amplifiers. As mentioned above, the output of a TWT amplifier degrades between adjustments. On the day of adjustment,

TWT Retrofit: High Power Common Carrier

it will put out its rated power and gradually drop until it needs to be readjusted or a low output alarm comes on at about 3 dB below rated power. Experience has shown that the average output of a tube-type amplifier is 2 dB below design value which corresponds to a 2 dB reduction in fade margin and 59% increase in outages. Since the output power of a solid state amplifier is not affected by the "sag" of cathode erosion as in a TWT, the transmitter is always putting out its rated power. This results in lower thermal noise in the receiver and a better fade margin, thus a quieter system with increased availability.

System Loading Maximization

Here is an example. The 6 GHz band can support 1800-2400 voice circuits in its 30 MHz channels. However, a number of users have found that routes designed and engineered to rigid noise budgets will not meet noise objectives when loaded beyond 600-1200 circuits. Testing short sections of facilities (6-10 hops) may show that each section is performing exactly as engineered. However, when four or five sections are tested in tandem, it may be found that the total picowatts of noise measured is two to three times the sum of the noise measured on each of the short sections.

Here's why. Picowatts are a measure of power; adding sections results in power addition, that is, 10 log addition. The same results can be obtained by combining the dBnc0 readings of the shorter sections on a power ratio (again 10 log) basis. It is very difficult to determine the amount of 20 log

(voltage addition) noise in a per hop or short section test, since, in a short section, the 20 log noise may be completely masked by the sources of 10 log noise. On longer sections it can quickly become predominant.

The most common cause of this type of noise is AM/PM conversion in the traveling wave tube amplifier and in the upconverter. TWT amplifiers normally have AM/PM conversion of 4 to 8 degrees per dB. HP solid state retrofit amplifiers typically perform at 1.5°/dB across the 500 MHz band. Replacement of the TWT with an HP solid state low AM/PM amplifier will significantly reduce intermodulation noise due to reduced AM/PM conversion in the transmitting amplifier. With 2 dB reduction in thermal noise by eliminating TWT output sag and with four to five dB improvement in intermodulation noise due to AM/PM reduction, it is possible to fully utilize the 1800 to 2400 channels of system design capability.

Driver Amp Upconverter AM/PM Relief

Depending upon the system that you are retrofitting, you may also be able to remove the AM/PM problem in your upconverter. If your system normally drives the TWT at a level higher than 0 dBm, you could drop the level of IF signal into the driver amplifier section of the upconverter such as to give 0 dBm at the upconverter output. Then, by using the full gain of the HP solid state amplifier, you can maintain a +40 dBm output. Dropping the level into the driver amplifier 4-10 dB should significantly reduce the 20 log noise component.

AWP Series — High Power TWT Replacement Amplifiers

Guaranteed Specifications @ 25°C Case Temperature

Model	Frequency Range (GHz)	RF Input Power (dBm)	Gain (dB)	Output Power ¹² (watts/dBm)	Noise Figure (dB) Max.	AM/PM Conver	Output Power Variation 0° to +55°C (dB) Max.	Output Power Flatness (dB) P-P	Envelope Delay Distortion (nsec) P-P	Harmonics (dBc) Max.	Spurious (dBc) Max.	Return Loss (dB)		Input Power ¹³ DC watts ⁹	Case Type
						Typ./Max.						Min.	Output		
AWP-42100	3.7-4.2	Note 1	Note 2	10/+40	10 ³	1.5/3	±2.5	±.25 ⁴	±1 ⁶	-53	-60	20	20	76	RJA
AWP-64100	5.925-6.425	Note 1	Note 2	10/+40	10 ³	1.5/2	±2.5	±.25 ⁵	±1 ⁷	-53	-60	20	20	76	RJA
AWP-64105	5.925-6.425	Note 1	Note 2	10/+40	10 ³	1.5/2	±2.5	±.25 ⁵	±1 ⁷	-53	-60	20	20	76	PHL
AWP-64105F	5.925-6.425	Note 1	Note 14	10/+40	10 ³	1.5/2	±2.5	±.25 ⁵	±1 ⁷	-53	-60	20	20	76	CJL
AWP-71100	6.4-7.1	Note 1	Note 2	10/+40	10 ³	1.5/3	±2.5	±.25 ¹⁰	±1 ¹¹	-53	-60	20	20	76	RJA
AWP-77100	7.1-7.7	Note 1	Note 2	10/+40	10 ³	1.5/3	±2.5	±.25 ¹⁰	±1 ¹¹	-53	-60	20	20	76	RJA
AWP-83100	7.7-8.3	Note 1	Note 2	10/+40	10 ³	1.5/3	±2.5	±.25 ¹⁰	±1 ¹¹	-53	-60	20	20	76	RJA
AWP-117500	10.7-11.7	Note 1	Note 8	5/+37	10	1.5/3	±2 ¹⁶	±.25 ¹⁰	±1 ¹¹	-53	-60	18	18	76	RJA

Notes:

1. Accepts any input level from -1 to +10 dBm for rated output power.
2. Gain adjustable from 30 to 41 dB for an output power level of +40 dBm.
3. At maximum gain.
4. Peak-to-peak across any 20 MHz band at +40 dBm output power.
5. Peak-to-peak across any 30 MHz band at +40 dBm output power.
6. Peak-to-peak across any 20 MHz band.
7. Peak-to-peak across any 30 MHz band.
8. Gain adjustable from 27 to 38 dB for an output power of +37 dBm.
9. At -24 or -48 VDC.
10. Peak-to-peak across any 40 MHz band at rated output power.
11. Peak-to-peak across any 40 MHz band.
12. At nominal input.
13. 1 dB compressed.
14. ±0.75 dB over +10°C to +45°C.
15. Maximum output power variation from 0° to +50°C.

ALL OTHER PARAMETERS THE SAME AS THE AWP 64105 EXCEPT CASE (FOR CASE REFER TO ATTACHED INSTALLATION DWG.)

Retrofit Product Selection Guide

	AWP-42100	AWP-64100	AWP-46105	AWP-640500	AWP-640604	AWP-640700	AWP-77100	AWP-83100	AWP-117500
Collins									
MS109E	X								
MS109E1	X								
MS109ES	X								
MW109E		X							
MW109E1		X							
MDR6			X						
MW109A3		X							
MW109B3		X							
MW609E									X
MW609E1/MW618									X
Lenkurt									
CTR108	X								
775G	X								
775A						X			
TELETTTRA									
HT 12/4	X								
HT 12/6L		X							
HT 12/6						X			
HT 12/8								X	
GTE									
CTR 106		X							
SEL									
FM 1800		X							
775C							X		
775D									X
NEC									
6G78MB		X							
Northern Telecom									
RA3T4	X								
RA3T6		X							
RD3								X	
Raytheon									
KTR3A/E		X							
KTR3TS		X							
RDS6200		X							
KTR3A/E11									X
RCA									
MM600		X							
Western Electric									
FR-6						X			
TD-2	X								
TD-3D	X								
660	X								
TH-1		X	X						
TH-3		X							
TMA1		X							
TM2/2A					X				

TWT RETROFIT Installation Drawing

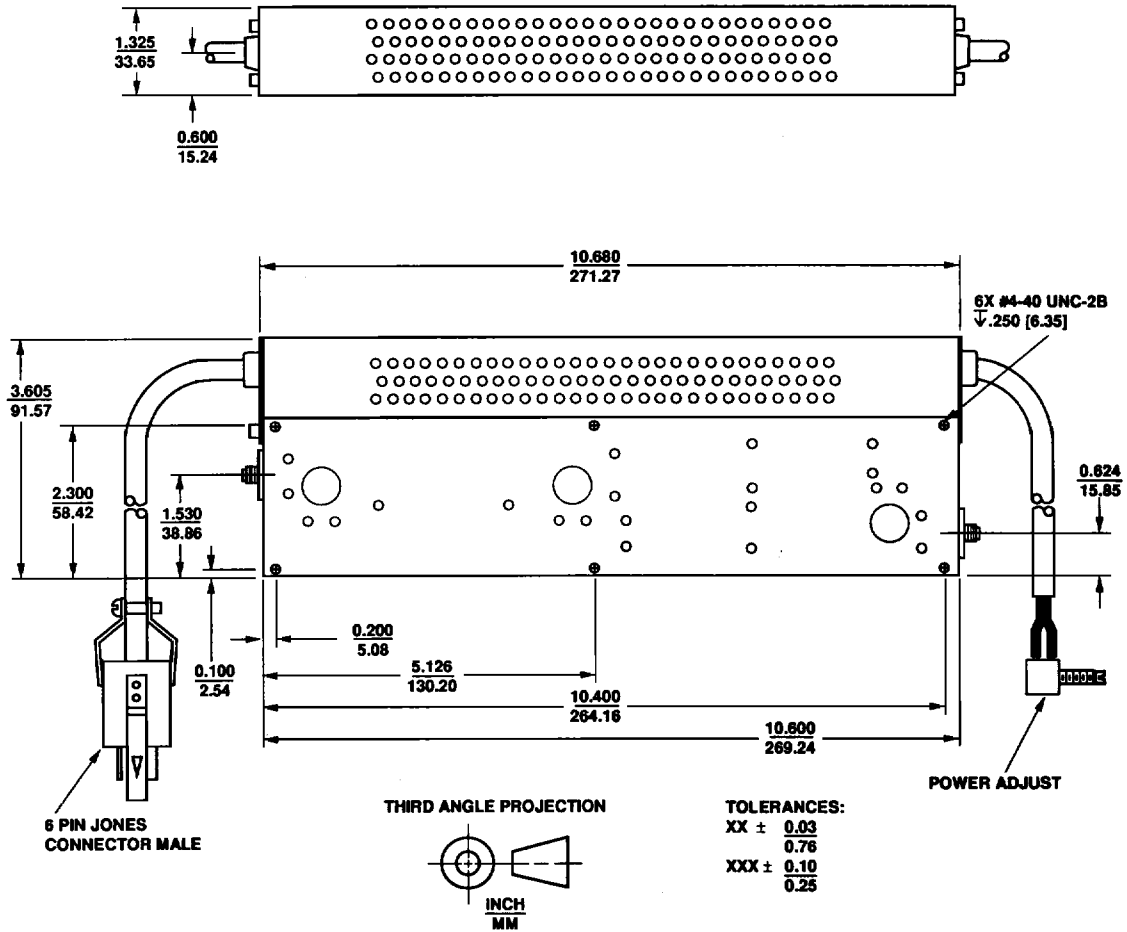

Case Drawing
PHL

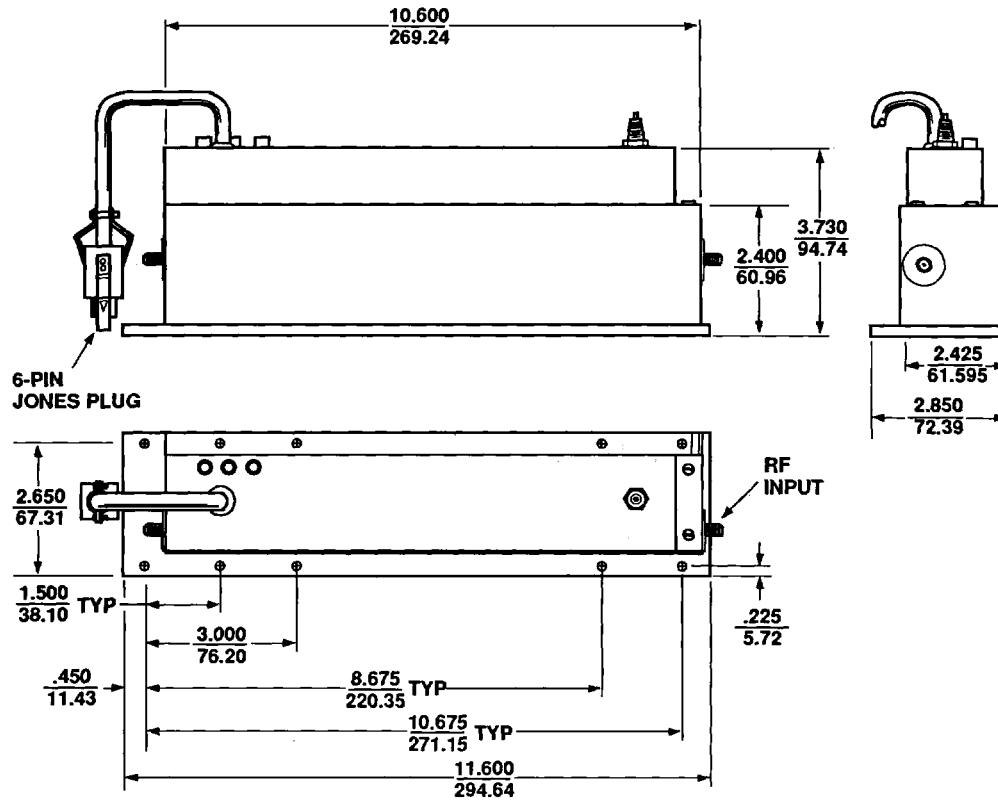

NOTES (UNLESS OTHERWISE SPECIFIED):

1. DIMENSIONS ARE SPECIFIED IN INCHES
MM

2. TOLERANCES: .XX ± 0.02
 $\pm .5$
.XXX ± 0.010
 $\pm .25$

TWT Retrofit:
High Power Common Carrier

Case Drawing
RJA

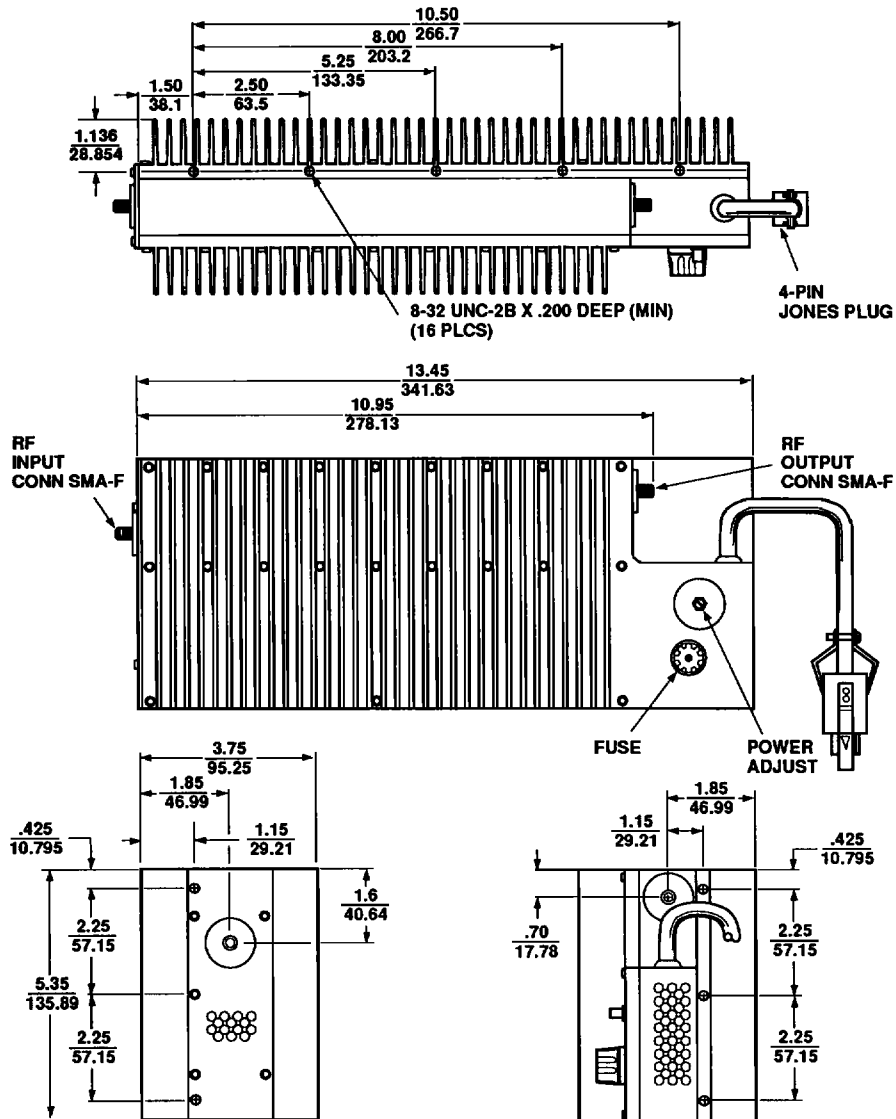

NOTES (UNLESS OTHERWISE SPECIFIED):

1. DIMENSIONS ARE SPECIFIED IN $\frac{\text{INCHES}}{\text{MM}}$
2. TOLERANCES: .XX ± 0.02
 $\pm .5$
 .XXX ± 0.010
 $\pm .25$

