



TAI-SAW TECHNOLOGY CO., LTD.

No. 3, Industrial 2nd Rd., Ping-Chen Industrial District,
Taoyuan, 324, Taiwan, R.O.C.

TEL: 886-3-4690038 FAX: 886-3-4697532

E-mail: tstsales@mail.taisaw.com Web: www.taisaw.com

Product Specifications Approval Sheet

Product Name: GPS L2+ Galileo E5b Band 1227.6MHz Front-End Module
1.5x1.1 mm(BW=52MHz)

TST Parts No.: TN0157A (This Part is qualified with AEC-Q100)

Customer Part No.: _____

<p>Company: _____</p> <p>Division: _____</p> <p>Approved by : _____</p> <p>Date: _____</p>
--

Checked by: _____ Jerry Xu *Jerry Xu.*

Approval by: _____ Ryan Huang *Ryan Huang*

Date: _____ 2019/09/04

1. Customer signed back is required before TST can proceed with sample build and receive orders.
2. Orders received without customer signed back will be regarded as agreement on the specifications.
3. Any specifications changes must be approved upon by both parties and a new revision of specifications shall be released to reflect the changes.



TAI-SAW TECHNOLOGY CO., LTD.

No. 3, Industrial 2nd Rd., Ping-Chen Industrial District,
Taoyuan, 324, Taiwan, R.O.C.

TEL: 886-3-4690038 FAX: 886-3-4697532

E-mail: tstsales@mail.taisaw.com Web: www.taisaw.com

GPS L2+E5b Band Front-End Module 1.5x1.1 mm

MODEL NO.: TN0157A

REV. NO.:1.0

A. GENERAL DESCRIPTION:

1. The TN0157A is a front-end module (FEM) designed for GPS L2 and Galileo E5b band applications.
2. The TN0157A offers low noise figure, high linearity, and high out-band rejection characteristics brought by included high performance pre-SAW filter and low noise amplifier (LNA).
3. The TN0157A offers only two external components, and very small package that is 1.5x1.1mm.



Electrostatic Sensitive Device (ESD)

B. RECOMMENDED OPERATING CONDITION: (Ta=25 °C)

PARAMETER	SYMBOL	MIN.	TYP.	MAX.	UNIT
Supply Voltage	V _{DD}	1.5	-	3.42	V

C. ABSOLUTE MAXIMUM RATINGS:

1. Supply voltage: V_{DD}=5 V
2. Control voltage: V_{CTL}=5 V
3. Input power:
 - P_{IN} (inband): +10 dBm(V_{DD}=2.8 V, f=1227.6, 1215~1239.6 MHz)
 - P_{IN} (outband): +25 dBm(V_{DD}=2.8 V, f=50~1050, 1250~4000 MHz)
4. Power dissipation: P_D=500 mW(4-layer FR4 PCB with through-hole(101.5x114.5 mm), T_j=100 °C)
5. Terminating source impedance: Z_s = 50 (Single-ended)
Terminating load impedance: Z_L = 50 (Single-ended)
6. Operating temperature range: -40 °C to +105 °C
7. Storage temperature range: -40 °C to +110 °C

D. FEATURES:

1. Low supply voltage: 1.8/ 2.8 V typ.
2. Low current consumption:
 - 3.0/3.7mA typ.(at V_{DD}=1.8/ 2.8 V, V_{CTL}=1.8 V)
 - 0.1µA typ.(at V_{DD}=1.8/ 2.8 V, V_{CTL}=0 V (Stand-by mode))
3. High gain: 17.2/17.9dB typ.(at V_{DD}=1.8/2.8 V, V_{CTL}=1.8 V, f=1227.6 MHz, 1197~1249MHz)
4. Low noise figure:
 - 2.2/2.28dB typ.(at V_{DD}=1.8/ 2.8 V, V_{CTL}=1.8 V, f=1227.6 MHz)

5. High out band rejection(at $V_{DD}=2.8\text{ V}$, $V_{CTL}=2.8\text{ V}$):

- 45 dBc typ.($f=1559\sim 1606\text{ MHz}$, relative to 1227.6 MHz)
- 57 dBc typ.($f=1710\sim 1980\text{ MHz}$, relative to 1227.6 MHz)
- 67 dBc typ.($f=2400\sim 2500\text{ MHz}$, relative to 1227.6 MHz)

6. Small package size: HFFP10-CD: 1.5mmx1.1mm (typ.), $t=0.5\text{mm}$ (max.)

7. Moisture Sensitivity Level: Level 3

E. ELECTRICAL CHARACTERISTICS 1 (DC):

(General conditions: $T_a=+25\text{ }^\circ\text{C}$)

Parameters Description		Symbol	Unit	Min.	Typ.	Max.
Supply Voltage		V_{DD}	V	1.5	-	3.3
Control Voltage (High)		$V_{CTL(H)}$	V	1.5	1.8	3.3
Control Voltage (Low)		$V_{CTL(L)}$	V	0	0	0.3
Supply Current 1	RF OFF, $V_{DD}=2.8\text{ V}$, $V_{CTL}=1.8\text{ V}$	I_{DD1}	mA	-	3.7	-
Supply Current 2	RF OFF, $V_{DD}=1.8\text{ V}$, $V_{CTL}=1.8\text{ V}$	I_{DD2}	mA	-	3.0	-
Supply Current 3	RF OFF, $V_{DD}=2.8\text{ V}$, $V_{CTL}=0\text{ V}$	I_{DD3}	μA	-	0.1	3.0
Supply Current 4	RF OFF, $V_{DD}=1.8\text{ V}$, $V_{CTL}=0\text{ V}$	I_{DD4}	μA	-	0.1	3.0
Control Current	$V_{CTL}=1.8\text{ V}$	I_{CTL}	μA	-	5.0	12.0

F. ELECTRICAL CHARACTERISTICS 2 (RF):

(General conditions: $V_{DD}=2.8\text{ V}$, $V_{CTL}=2.8\text{ V}$, $f_{RF}=1227.6\text{ MHz}$, 1197~1249, $T_a=+25\text{ }^\circ\text{C}$, $Z_s=Z_l=50\text{ ohm}$, with application circuit)

Parameters Description		Symbol	Unit	Min.	Typ.	Max.
Small Signal Gain (GPS)	$f=1227.6\text{ MHz}$ (GPS) Exclude PCB, Connector Losses(0.17 dB)	GainGPS1	dB	17	17.9	-
Noise Figure (GPS)	$f=1227.6\text{ MHz}$ (GPS) Exclude PCB, Connector Losses (0.09 dB)	NFGPS1	dB	-	2.2	2.8
Input Power at 1dB Gain, Compression Point	$f=1227.6\text{ MHz}$	P-1dB(IN)1	dBm	-	-9.8	-
Input 3rd Order Intercept Point	$f_1=1227.6\text{ MHz}$, $f_2=f_1\text{ +/-}1\text{ MHz}$, $P_{in}=-30\text{ dBm}$	IIP3_1	dBm	-	-1.5	-
Low Band Rejection	$f=704\text{ to }915\text{ MHz}$, relative to 1176.45 MHz	BR_L1	dBc	40	46	-
GPS, GNS, BeiDou Rejection	$f=1559\text{ to }1606\text{ MHz}$, relative to 1227.6 MHz	BR_G1	dBc	40	45	-

High Band Rejection	f=1710 to 1980 MHz, relative to 1227.6 MHz	BR_H	dBc	50	57	-
WLAN Band Rejection	f=2400 to 2500 MHz, relative to 1227.6 MHz	BR_W	dBc	60	67	-
RF IN Return Loss (GPS)	f=1227.6 MHz (GPS L2)	RLiGPS	dB	14	19	-
RF OUT Return Loss(GPS)	f=1227.6 MHz (GPS L2)	RLoGPS	dB	18	23.4	-
Group Delay Time Deviation	f=1215 to 1237 MHz (GPS L2)	GDTGLN1	ns	-	12	22

ELECTRICAL CHARACTERISTICS 3 (RF):

(General conditions: $V_{DD}=1.8$ V, $V_{CTL}=1.8$ V, $f_{RF}=1227.6$ MHz, 1197 to 1249, $T_a=+25$ °C, $Z_s=Z_l=50$ ohm, with application circuit)

Parameters Description		Symbol	Unit	Min.	Typ.	Max.
Small Signal Gain (GPS)	f=1227.6MHz (GPS) Exclude PCB, Connector Losses(0.17 dB)	GainGPS 1	dB	16	17.2	-
Noise Figure (GPS)	f=1227.6 MHz (GPS) Exclude PCB,Connector Losses (0.07 dB)	NFGPS1	dB	-	2.28	2.8
Input Power at 1dB Gain, Compression Point	f=1227.6 MHz	P-1dB(IN) 1	dBm	-	-9.8	-
Input 3rd Order Intercept Point	f1=1227.6 MHz, f2=f1 +/-1 MHz, Pin=-30 dBm	IIP3_1	dBm	-	-1.5	-
Low Band Rejection	f= 704 to 915MHz, relative to 1227.6 MHz	BR_L1	dBc	40	46	-
GPS, GNS, BeiDou Rejection	f=1559 to 1606 MHz, relative to 1227.6 MHz	BR_G1	dBc	40	46	-
High Band Rejection	f=1710 to 1980 MHz, relative to 1227.6 MHz	BR_H	dBc	50	58	-
WLAN Band Rejection	f=2400 to 2500 MHz, relative to 1227.6 MHz	BR_W	dBc	60	67	-
RF IN Return Loss (GPS)	f=1227.6 MHz (GPS L2)	RLiGPS	dB	8	12	-
RF OUT Return Loss(GPS)	f=1227.6 MHz (GPS L2)	RLoGPS	dB	17	23	-
Group Delay Time Deviation	f=1197 to 1249 MHz (GPS L2+E5b)	GDTGLN	ns	-	12	22
Group Delay Time Deviation	f=1215 to 1239.6 MHz (GPS L2)	GDTGLN	ns	-	2.3	10

FREQUENCY CHARACTERISTICS 1:

(Conditions: $V_{DD}=2.8$ V, $V_{CTL}=2.8$ V, $T_a=25$ °C, $Z_s=Z_l=50$ ohm, with application circuit.)

Transfer function:

S21 response (span: 200 MHz)

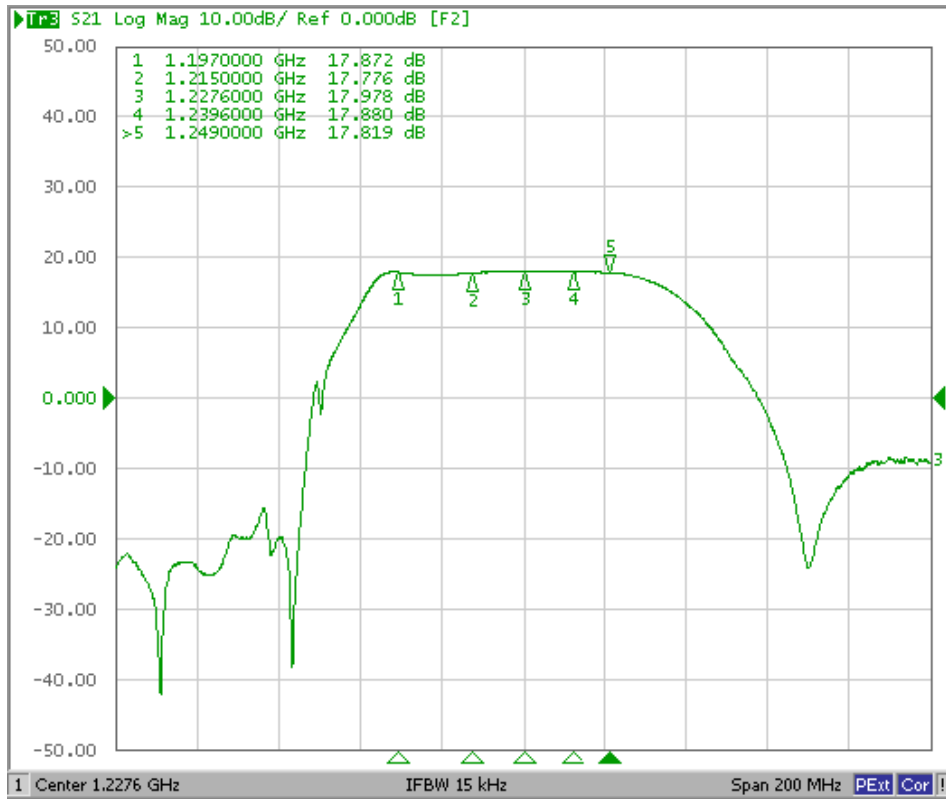

S21 response

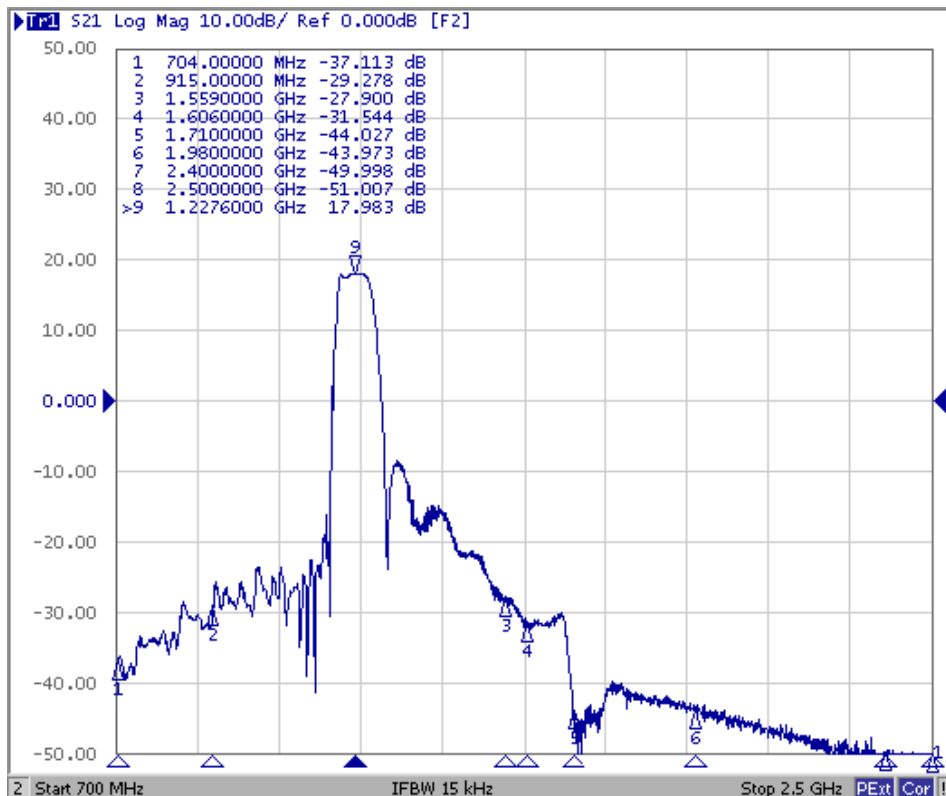

Group Delay (L2)

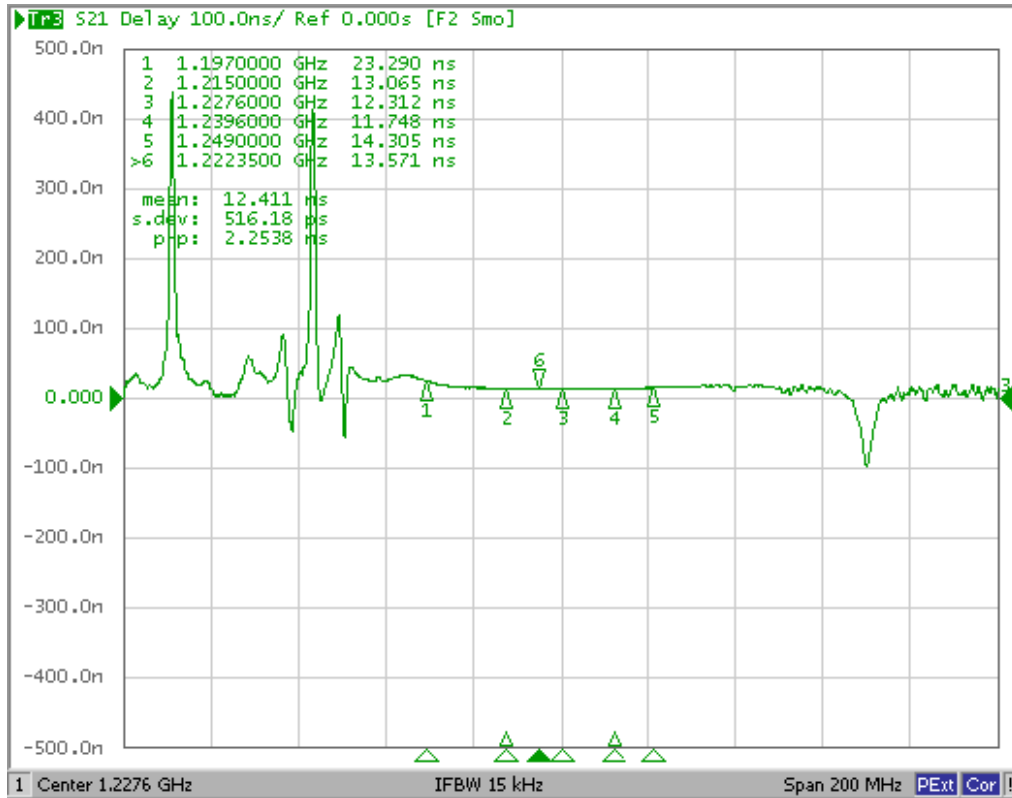

Group Delay (L2+E5b)

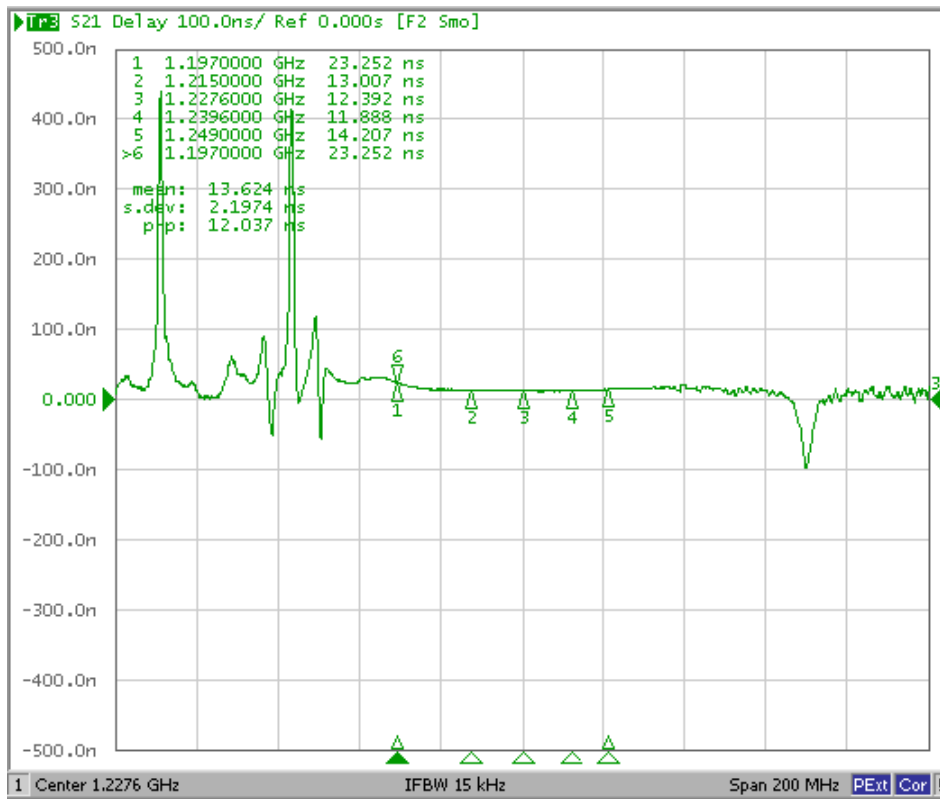

**Reflection functions:
S11 VSWR**

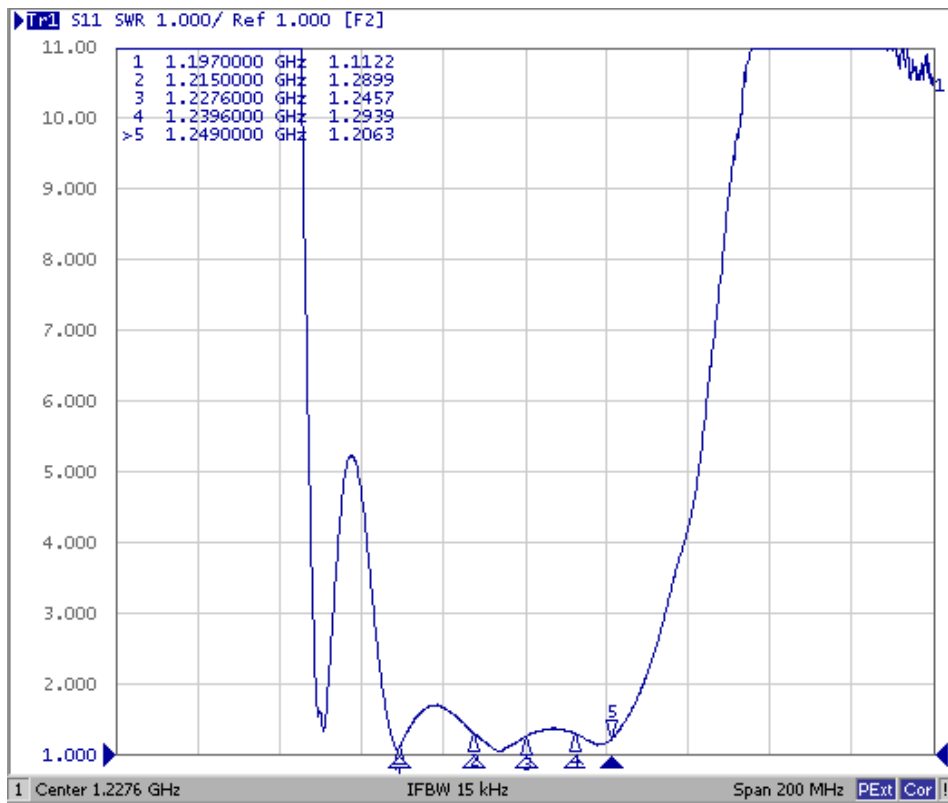

S22 VSWR

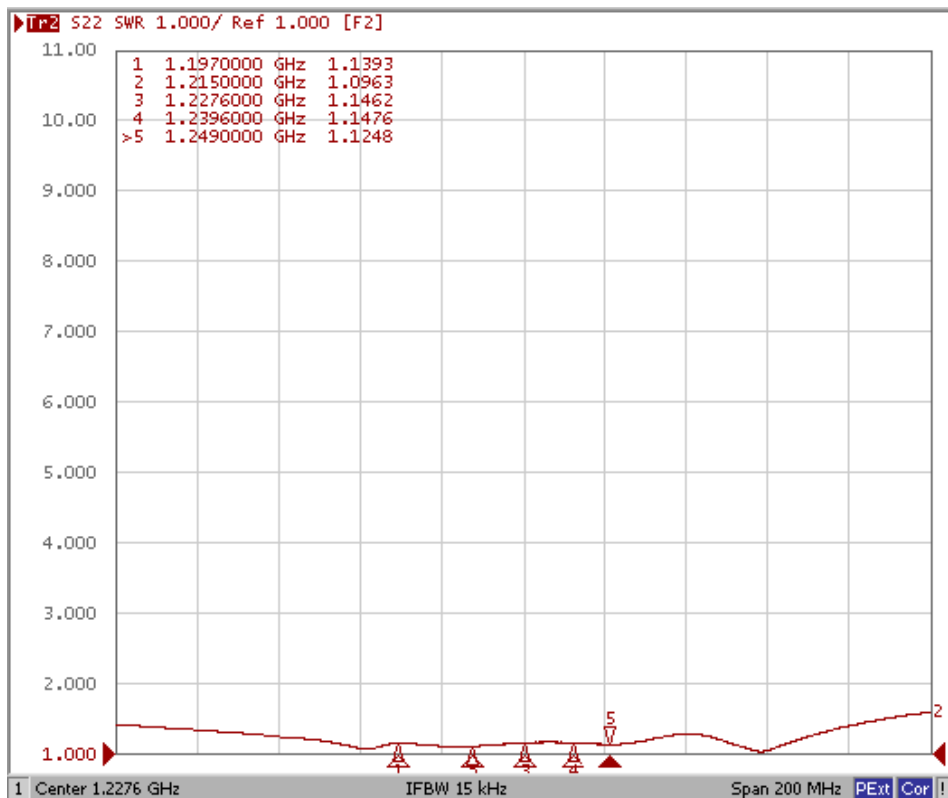

S11 Smith Chart

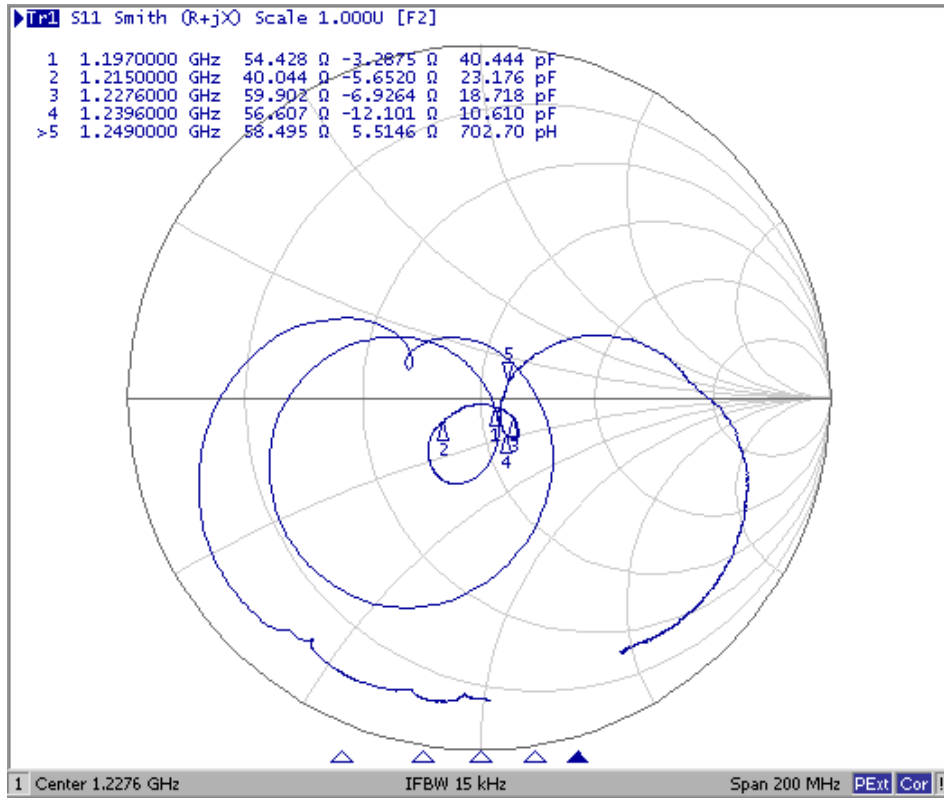

S22 Smith Chart

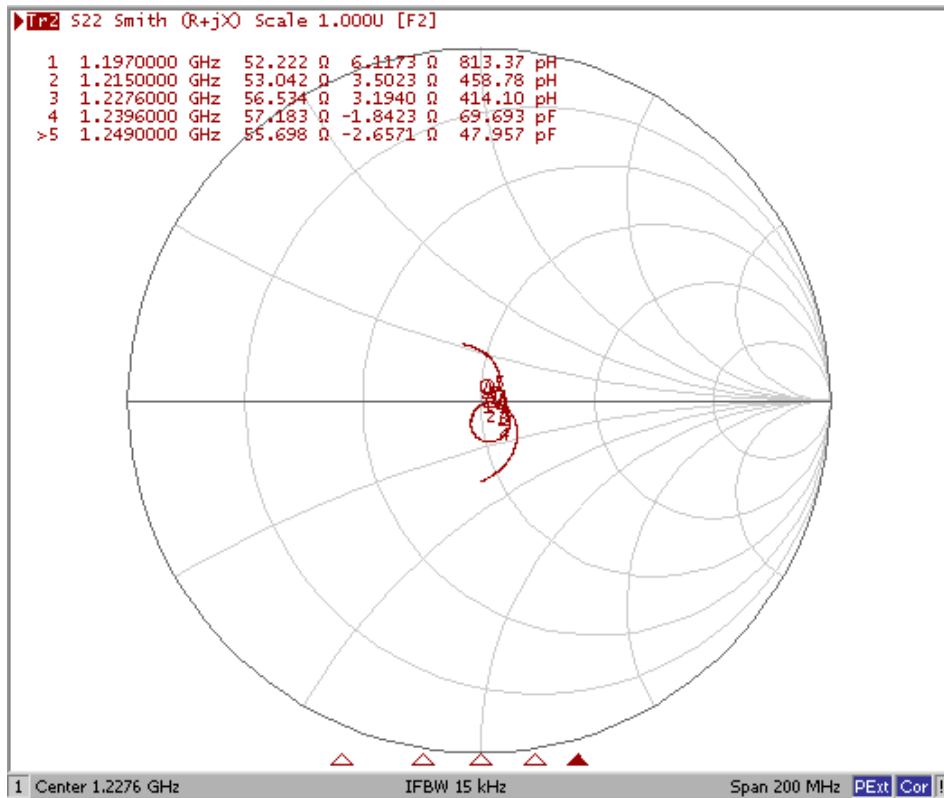

S11 Return Loss

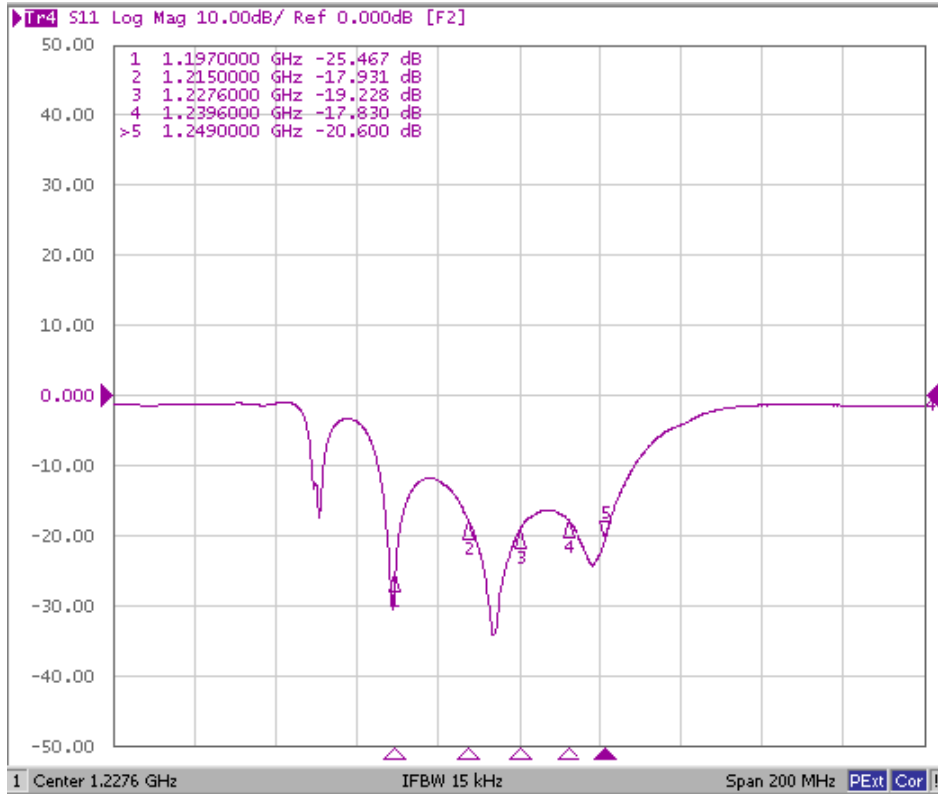

S22 Return Loss

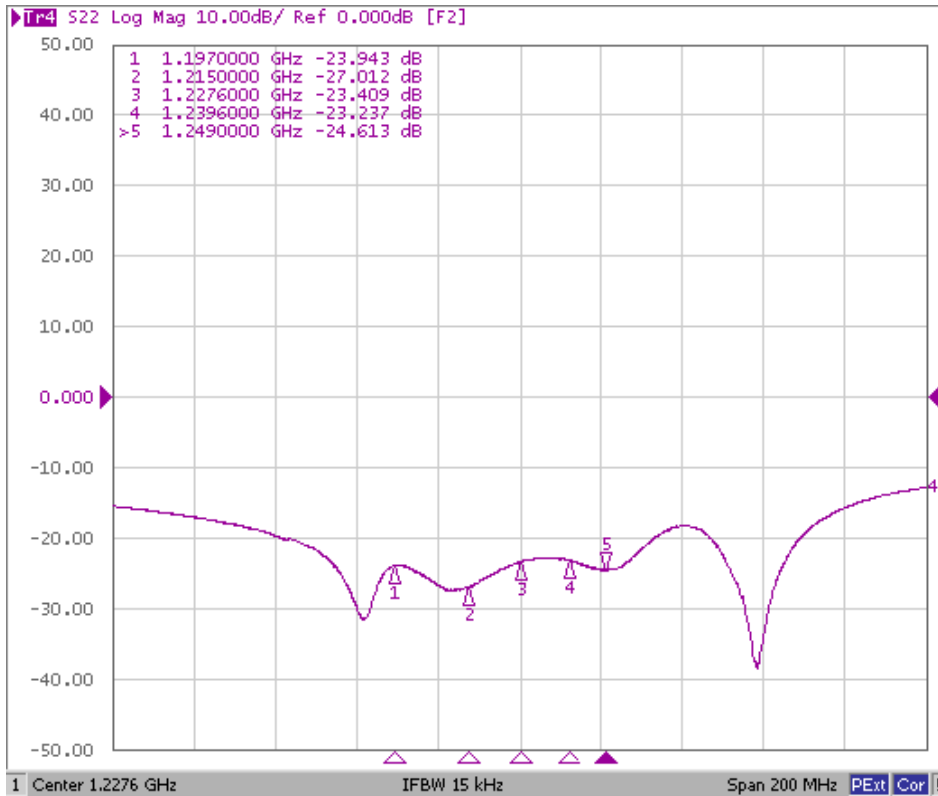

G. MEASUREMENT CIRCUIT:

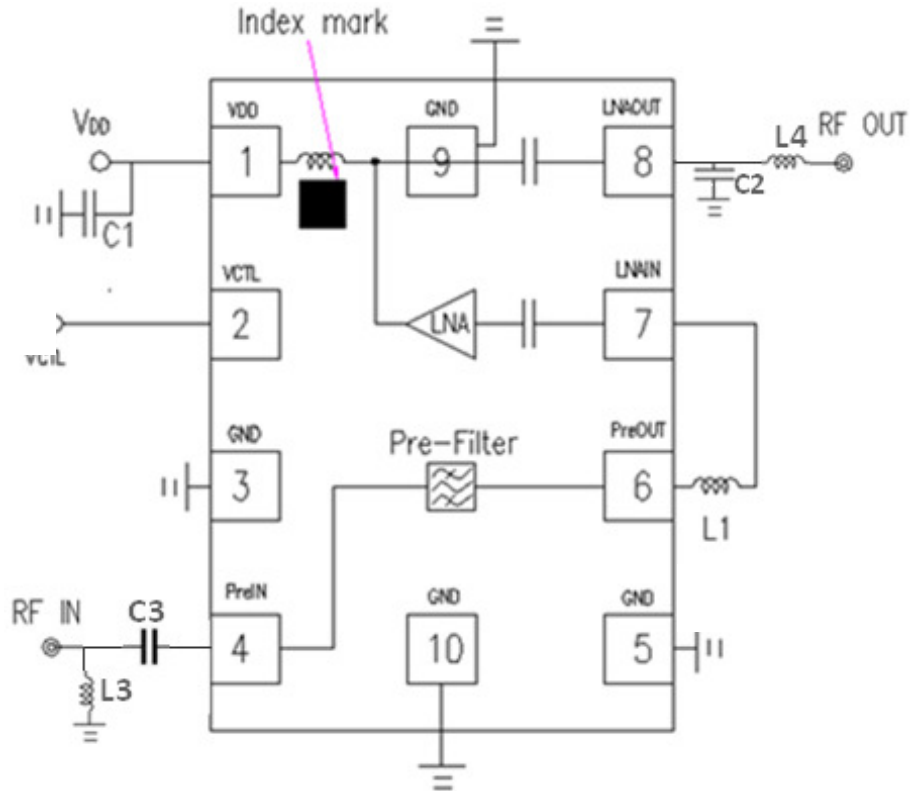

Parts ID	Manufacture	Value
L1	Murata LQW15A_00 Series	24nH
C1	Murata GRM03 Series	1000pF
L3	Murata LQW15A Series	10nH
C3	Murata LQW15A Series	8.0pF
C2	Murata GRM03 Series	1.0pF
L4	Murata GRM03 Series	6.8nH

H. PACKAGE OUTLINE:

UNIT: mm

Top View

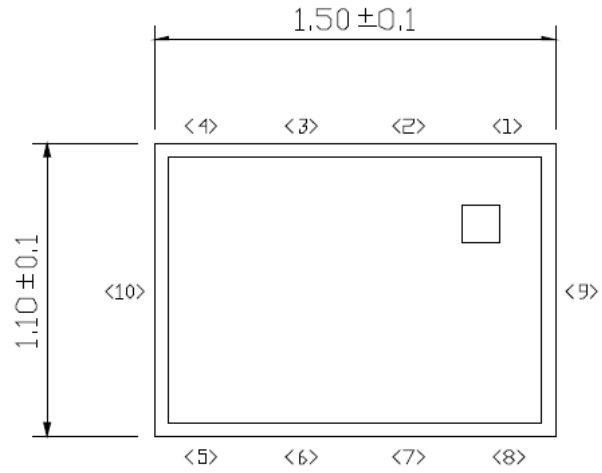

Side View

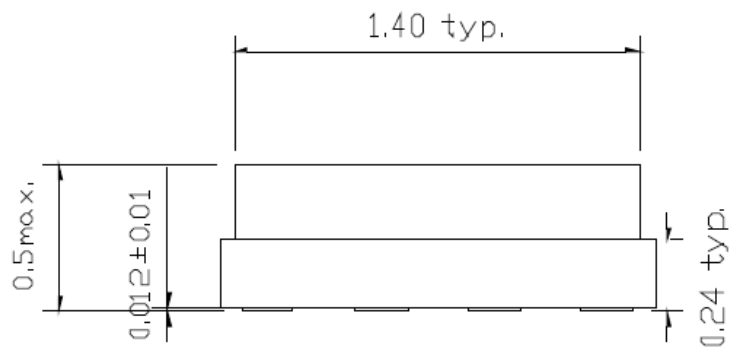

Bottom View

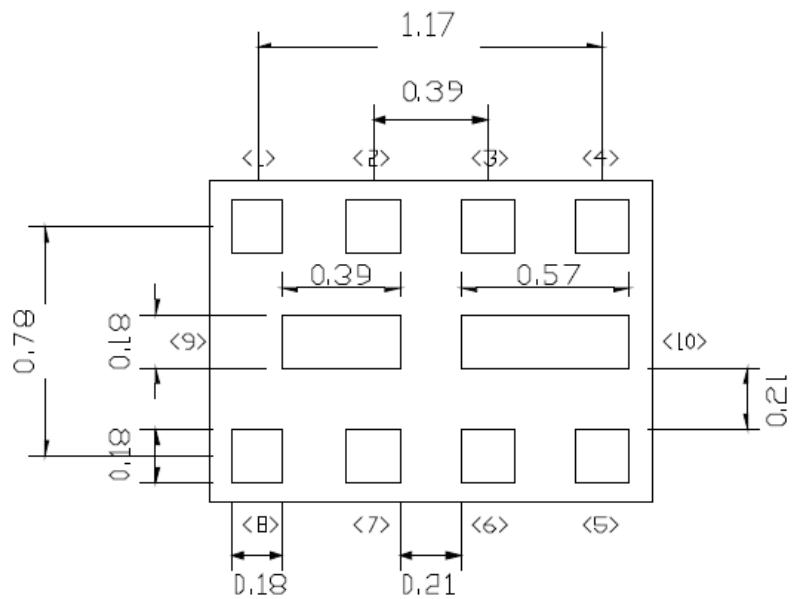

Electrode Dimensions clearance: ± 0.05 mm

Stand-off: 0.1 mm max.

Substrate: Ceramic

Terminal treat: Au

Lid: Epoxy film

Weight (typ.): 5 mg

I. OUTLINE DRAWING:

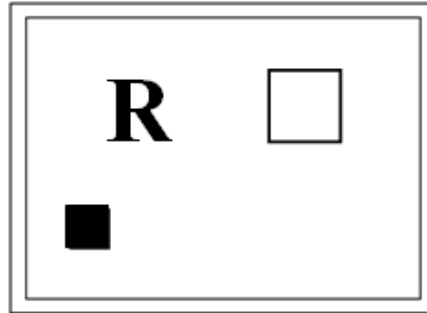

□ : Year/Month Code (Follow the table)

YEAR/Month	1	2	3	4	5	6	7	8	9	10	11	12
2013	A	B	C	D	E	F	G	H	J	K	L	M
2014	N	P	Q	R	S	T	U	V	W	X	Y	Z
2015	a	b	c	d	e	f	g	h	j	k	l	m
2016	n	p	q	r	s	t	u	v	w	x	y	z
2017	<u>A</u>	<u>B</u>	<u>C</u>	<u>D</u>	<u>E</u>	<u>F</u>	<u>G</u>	<u>H</u>	<u>J</u>	<u>K</u>	<u>L</u>	<u>M</u>
2018	<u>N</u>	<u>P</u>	<u>Q</u>	<u>R</u>	<u>S</u>	<u>T</u>	<u>U</u>	<u>V</u>	<u>W</u>	<u>X</u>	<u>Y</u>	<u>Z</u>
2019	<u>a</u>	<u>b</u>	<u>c</u>	<u>d</u>	<u>e</u>	<u>f</u>	<u>g</u>	<u>h</u>	<u>j</u>	<u>k</u>	<u>l</u>	<u>m</u>
2020	<u>n</u>	<u>p</u>	<u>q</u>	<u>r</u>	<u>s</u>	<u>t</u>	<u>u</u>	<u>v</u>	<u>w</u>	<u>x</u>	<u>y</u>	<u>z</u>

J. PIN CONFIGURATION:

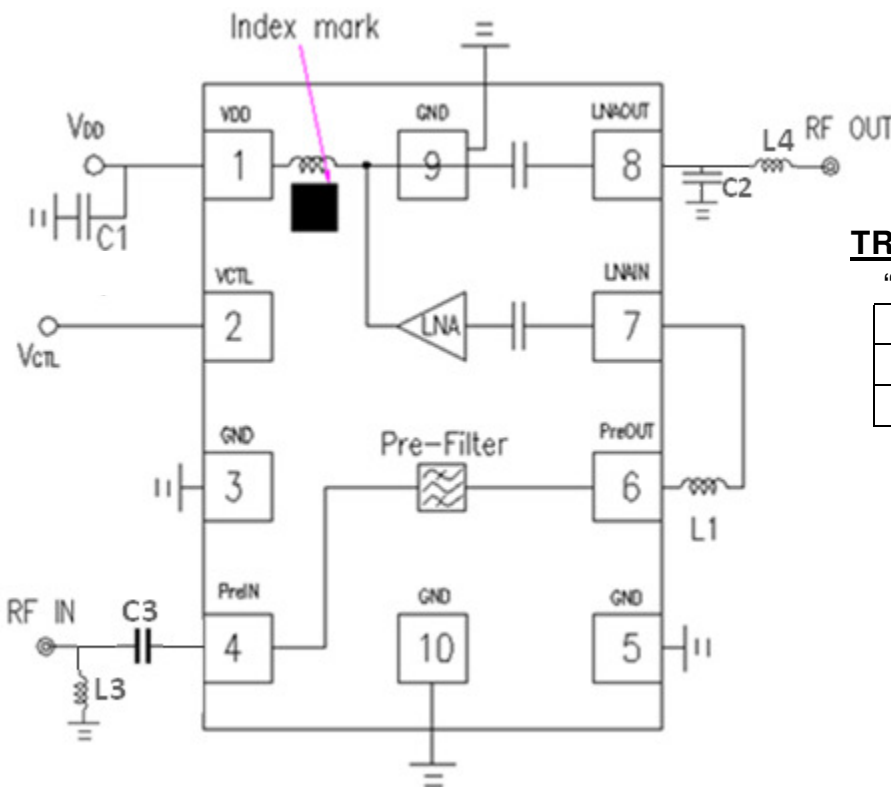

TRUTH TABLE

“H”=V_{CTL}(H), “L”=V_{CTL}(L)

VCTL	Mode
H	Active mode
L	Stand-by mode

No.	SYMBOL	DESCRIPTION
1	VDD	Supply voltage terminal. Please connect bypass capacitor C1 with ground as close as possible.
2	VCTL	Control voltage terminal.
3	GND	Ground terminal. This terminal should be connected to the ground plane as close as possible for excellent RF performance.
4	PreIN	RF input terminal. This terminal connects to input of pre-SAW filter.
5	GND	Ground terminal. This terminal should be connected to the ground plane as close as possible for excellent RF performance.
6	PreOUT	Pre-SAW filter output terminal. This terminal connects to LNAIN with L1.
7	LNAIN	RF input terminal. This terminal requires only a matching inductor L1, and does not require DC blocking capacitor because of integrated capacitor.
8	LNAOUT	RF output terminal. This terminal requires no DC blocking capacitor since this terminal has integrated DC blocking capacitor.
9	GND	Ground terminal. This terminal should be connected to the ground plane as close as possible for excellent RF performance.
10	GND	Ground terminal. This terminal should be connected to the ground plane as close as possible for excellent RF performance.

K. EVALUATION BOARD:

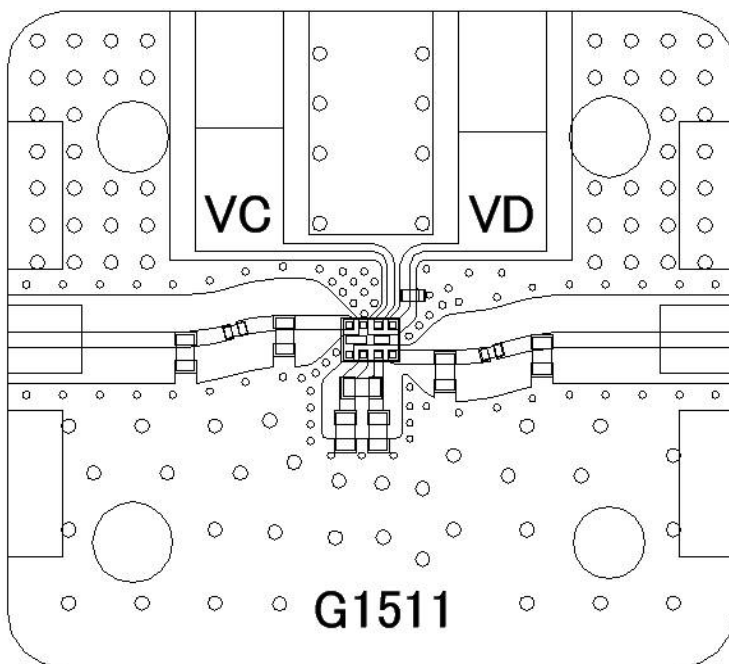

PCB

Substrate: TLX-9





Thickness: 0.12 mm

Microstrip line width: 0.322 mm($Z_0=50 \Omega$)

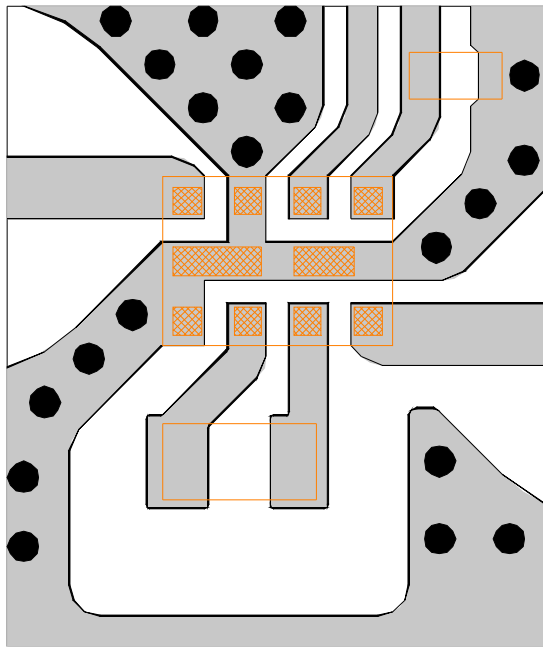
Size: 14.0 mm x 14.0 mm

<PCB LAYOUT GUIDELINE>



-  PCB
-  PKG Terminal
-  PKG Outline
-  GND Via Hole
Diameter = 0.2 mm

PRECAUTIONS

- Please layout ground pattern under this FEM in order not to couple with RFIN and RFOUT terminal.
- All external parts should be placed as close as possible to the FEM.
- For good RF performance, all GND terminals must be connected to PCB ground plane of substrate, and via-holes for GND should be placed near the FEM.

L. RECOMMENDED FOOTPRINT PATTERN:

PKG: 1.5 mm x 1.1 mm

Pin pitch: 0.39 mm

 : Land

 : Mask (Open area) *Metal mask thickness: 100 μm

 : Resist (Open area)

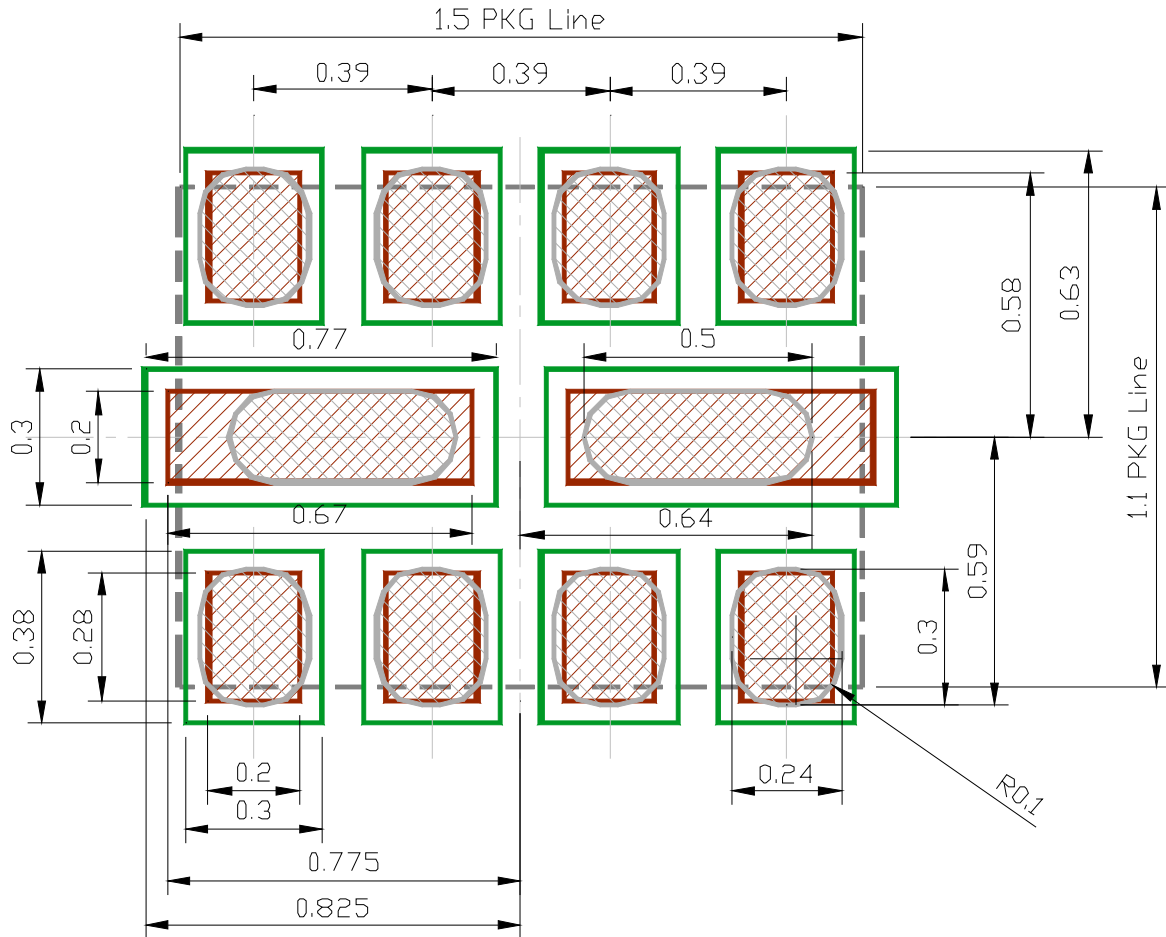

M. PACKING SPECIFICATION:

【TAPING DIMENSION】

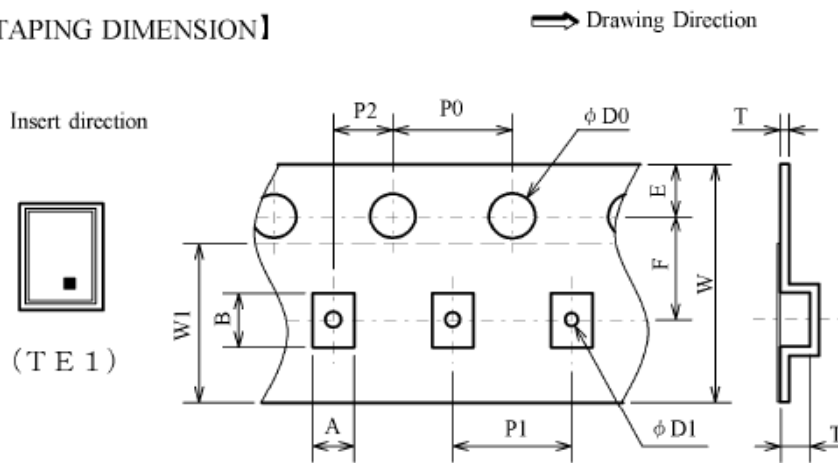

SYMBOL	DIMENSION	REMARKS
A	1.4±0.1	BOTTOM DIMENSION
B	1.8±0.1	BOTTOM DIMENSION
D0	1.5 ^{+0.1} _{-0.1}	
D1	0.5±0.05	
E	1.75±0.1	
F	3.5±0.05	
P0	4.0±0.1	
P1	4.0±0.1	
P2	2.0±0.05	
T	0.25±0.05	
T2	0.7±0.1	
W	8.0±0.2	
W1	5.3±0.2	THICKNESS 100um MAX

*Carrier tape material: PS (Anti-static)
Cover tape material: PET (Anti-static)

【REEL DIMENSION】

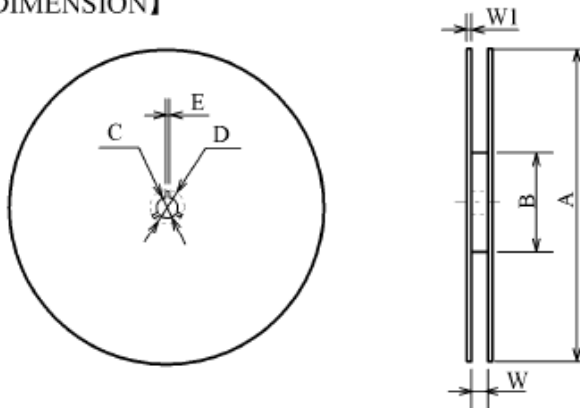

SYMBOL	DIMENSION
A	φ 180 ⁺⁰ _{-1.5}
B	φ 66±0.5
C	φ 13±0.2
D	φ 21±0.8
E	2±0.5
W	9 ^{+1.0} ₋₀
W1	1.2

*MATERIAL : PS carbon (Anti-static)

【TAPING STATE】

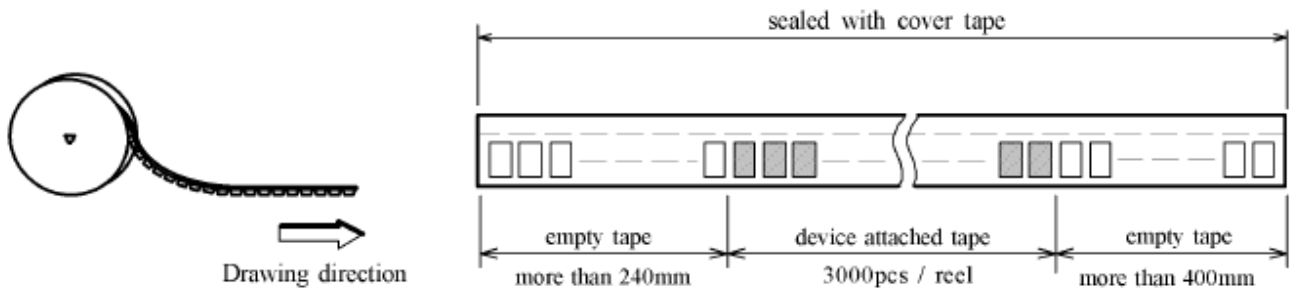

N. RECOMMENDED REFLOW PROFILE:

* Recommended reflow soldering procedure

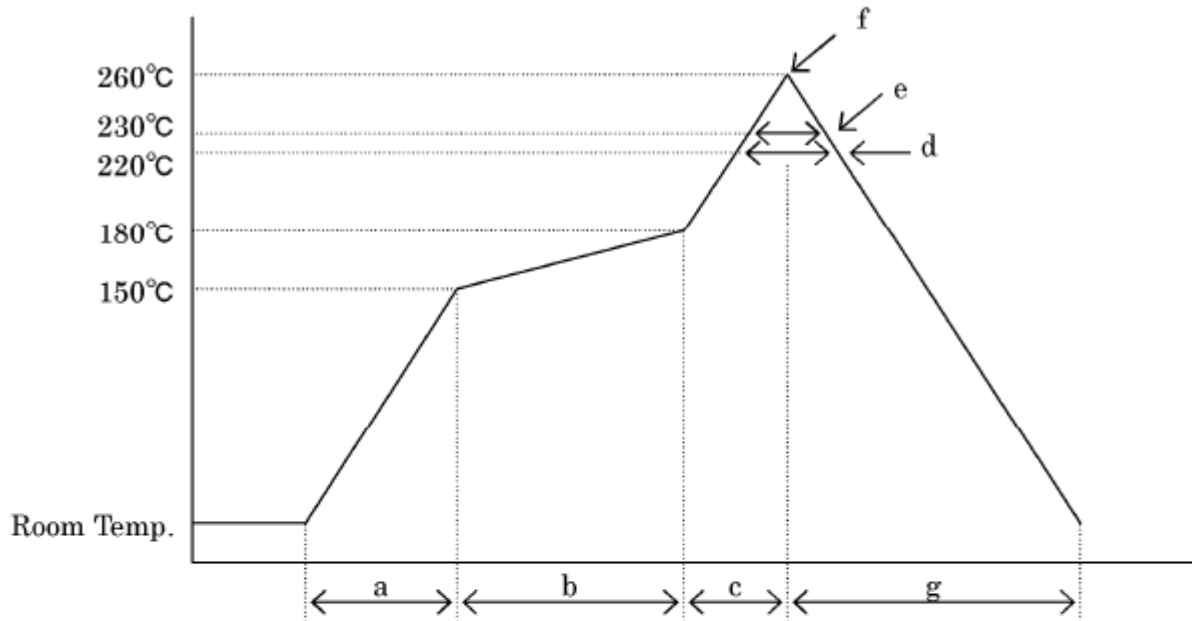

a: Temperature ramping rate	: 1 to 4°C/s
b: Pre-heating temperature	: 150 to 180°C
time	: 60 to 120s
c: Temperature ramp rate	: 1 to 4°C/s
d: 220°C or higher time	: Shorter than 60s
e: 230°C or higher time	: Shorter than 40s
f: Peak temperature	: Lower than 260°C
g: Temperature ramping rate	: 1 to 6°C/s

The temperature indicates at the surface of mold package.

Cautions on using this product

This product contains Gallium-Arsenide (GaAs) which is a harmful material.

- Do NOT eat or put into mouth.
- Do NOT dispose in fire or break up this product.
- Do NOT chemically make gas or powder with this product.
- To waste this product, please obey the relating law of your country.

This product may be damaged with electric static discharge (ESD) or spike voltage. Please handle with care to avoid these damages.