

Advance Product Information

VSC8161

2.488Gb/s SONET / SDH
16:1 Mux with Clock Generator and Laser Driver

Features

- 16:1 Multiplexer Integrated with Clock Multiplier and Laser Driver
- Monolithic Phase Locked Loop
- Laser Driver Provides up to 110 mA Current
- Differential 16-bit Parallel Data
- 100 pin 14x14 Plastic Quad Flat Package
- Jitter Generation Meets SONET OC-48 and SDH STM-16 Requirements
- Companion to the VSC8162 1:16 Demultiplexer with Clock Recovery
- Supports Parity Checking at the 16-bit Parallel Interface

General Description

The VSC8161 combines a Laser Driver and a clock multiplier with a 16:1 multiplexer to provide a single-chip solution. The 16-bit data word is latched by an internal version of the reference clock, and is bit-multiplexed up to 2.488GHz. The on-chip PLL generates the internal 2.488GHz clock, which remains locked to the 155.52 MHz reference clock. The on-chip laser driver provides up to 60 mA modulation current and 50 mA bias current.

VSC8161 Functional Block Diagram

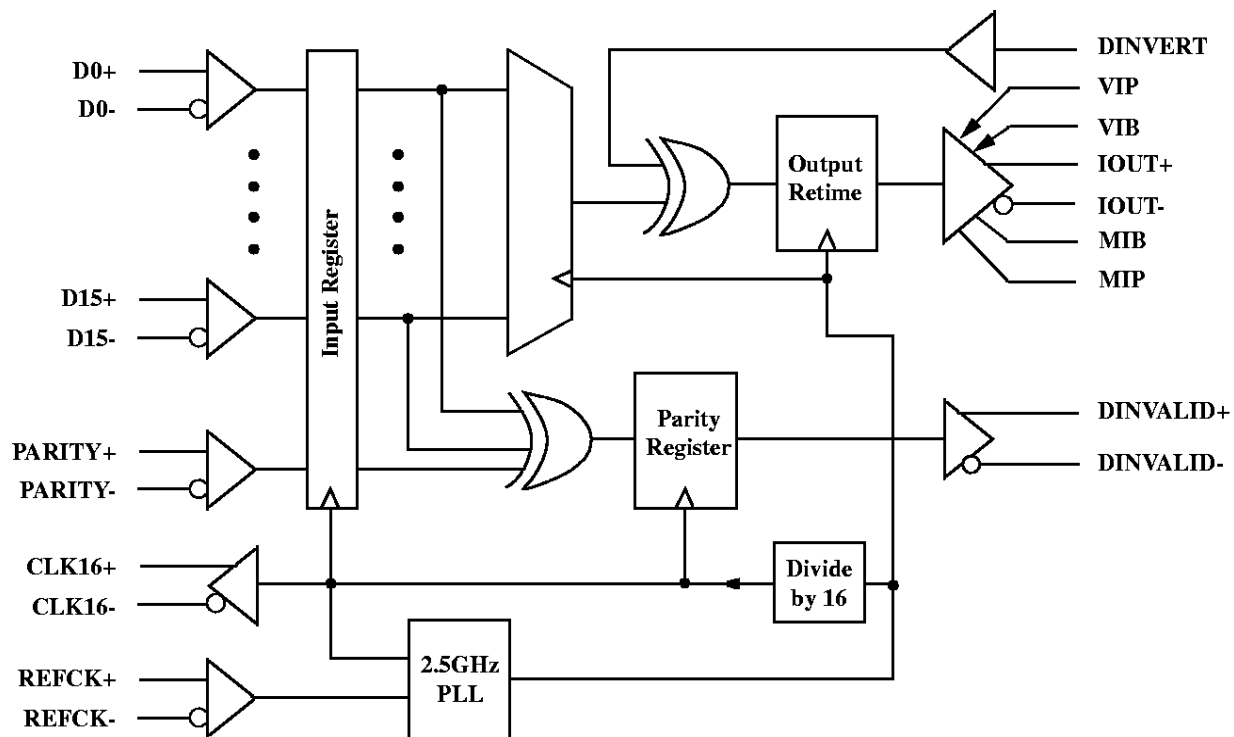

Functional Description

Multiplexer

The VSC8161 takes incoming 16-bit wide data at 155 MHz, D0 through D15, and converts it into a serial data stream, with D0 transmitted first. CLK16 is the 155MHz low-speed clock output which is created by dividing the internally generated 2.488 GHz clock by 16. The upstream device should use the CLK16 as its internal reference and to register its low-speed data and parity output signals (See Fig 1). Care needs to be taken to meet the data setup and hold timing on the parallel data.

Figure 1: VSC8161 Parallel Data Interface

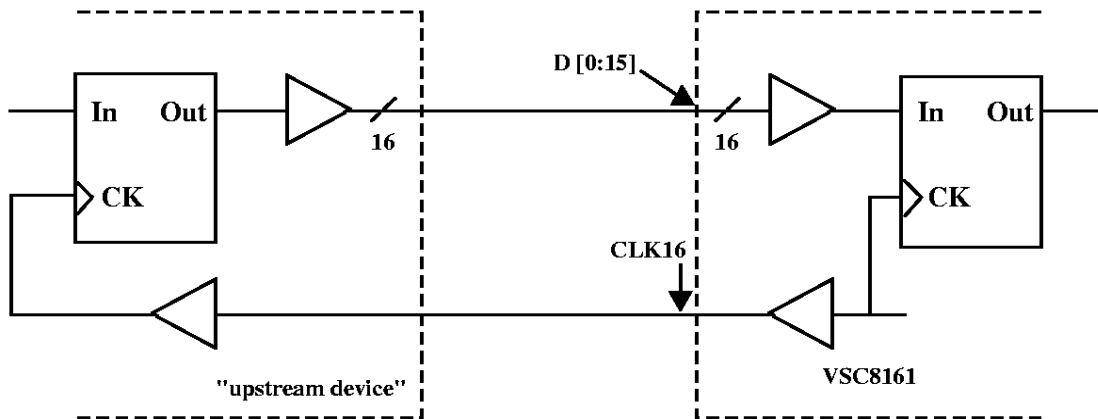

The timing relationship between the VSC8161 and the upstream device is described by the waveforms in Fig. 5 and the associated parameters: t_D , t_{DSU} , and t_{DH} appearing in Table 1.

The polarity of the serialized data can be inverted by the assertion of the DINVERT input. In either case, however, the signal is retimed prior to the Laser Driver section of the VSC8161.

Clock Multiplier

The clock multiplier is fully integrated. No external components are needed. Jitter Generation of the clock multiplier meets the requirement of Bellcore's GR-253 (SONET) document. As in all of the frequency synthesizers that employ a PLL, it is important to choose REFCK to be as *jitter-free* as possible.

Advance Product Information

VSC8161

2.488Gb/s SONET / SDH
16:1 Mux with Clock Generator and Laser Driver

Figure 2: Single-ended AC-Coupling for REFCK+, REFCK- Inputs

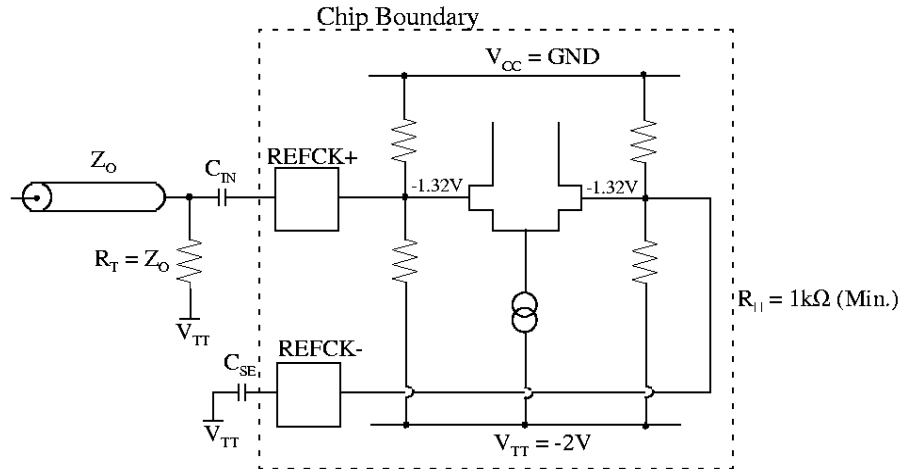

C_{IN} TYP = 0.1 μ F

C_{SE} TYP = 0.1 μ F for single ended applications. (Capacitor values are selected for REFCK = 155.52 MHz)

A differential input buffer is used to supply the reference clock to the clock multiplier. Internal biasing will position the reference voltage of approximately -1.32V on both the true and complement inputs. This input can either be DC-coupled or AC-coupled; it can also be driven single-ended or differentially. Figure 2 shows the configuration for single-ended, AC-coupled operation. In the case of direct coupled and single-ended input, it is recommended that a stable V_{REF} for ECL levels be used for the complementary input if the input common mode voltage is not -1.32V.

Parity

Systems employing internal parity are supported by the VSC8161. A parity check is performed between the PARITY input and the 16 data bits. Even parity is expected. In other words, the DINVALID output is the XOR of all 16 parallel data bits and the PARITY input. If the Exclusive-OR gate fails to confirm even parity, the DINVALID output will be asserted. DINVALID becomes available t_{DV} after the falling edge of CLK16. DINVALID is a NRZ pulse that is updated every 6.4 ns, i.e., the period of CLK16. The timing relationship of DINVALID to CLK16 is shown in Figure 6.

The DINVALID pins may be left open if parity is unused.

Laser Driver

The laser driver contained in the VSC8161 provides up to 50mA of DC bias current and 60 mA of modulation current. Direct control of the laser bias and modulation current is provided. Laser bias and modulation current levels are monitored and controlled using external components.

A schematic representation of the laser driver output stage showing the relationship between the external controls signals and the internal circuitry is provided in Figure 3.

Figure 3: Laser Driver Output

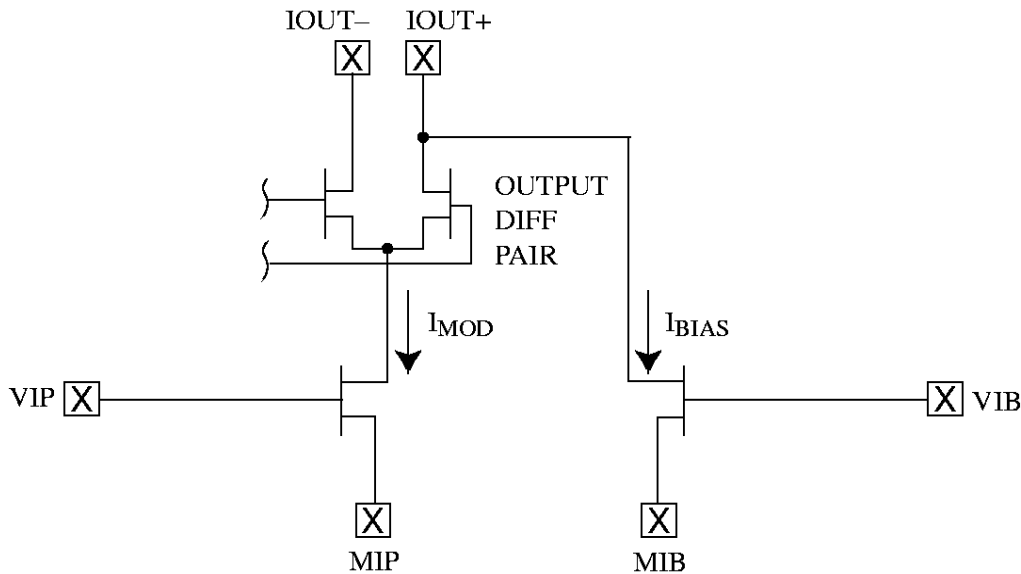

IOUT+, IOUT- Outputs

The IOUT+ and IOUT- pins are designed to interface to a laser diode. A logic “0” appears as less current (higher voltage) at the IOUT+ pin, and less light from a series laser diode. A logic “1” appears as more current (lower voltage) at the IOUT+ pin, and more light from a series laser diode. The polarity can be reversed through use of the DINVERT signal pin. The current difference depends upon the voltage (VIP - MIP) applied at the VIP pin. Applying (VIP - MIP) = 0V will turn off the modulation current. Applying (VIP - MIP) = approximately 2V will maximize the modulation current. Applying (VIP - MIP) up to 5.2V is allowed, but not likely to be useful. Use caution to avoid exceeding the absolute maximum current ratings (see table). Operation of the bias current is independent of, and similar to, the operation of the modulation current. Pins MIB and VIB are used to monitor and control the bias current.

It is recommended that feed back circuits be utilized to regulate the desired modulation and bias currents. This is illustrated with examples in figure 4. Separate circuits are used, since the modulation and bias currents are independent.

Advance Product Information

VSC8161

2.488Gb/s SONET / SDH
16:1 Mux with Clock Generator and Laser Driver

Figure 4: Recommended Modulation and Bias Current Control Circuits

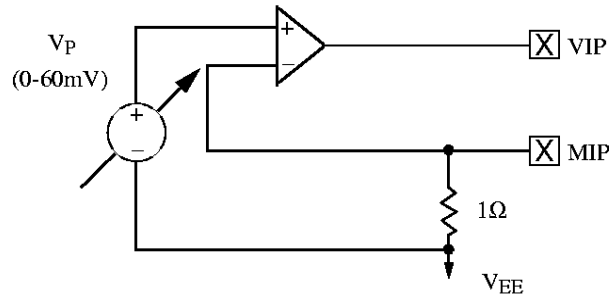

Modulation Current Control Circuit

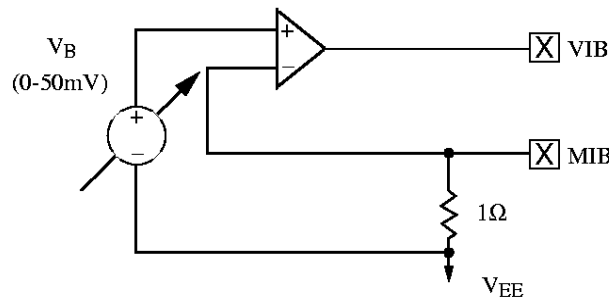

Bias Current Control Circuit

For Example to get 40mA of modulation current, V_p is set to 40mV ($40mA \times 1\Omega = 40mV$)

Supplies

The VSC8161 is designed to operate with $V_{EE} = -5.2V$, $V_{TT} = -2.0V$ and $V_{CC} = GND (0.0V)$. However, the part can be operated in an all positive supply environment, or a mixed positive and negative supply environment.

To operate in an all positive supply environment, each of the supply voltages must be shifted up by 5.2V such that V_{EE} will now be GND, $V_{TT} = +3.2V$ and $V_{CC} = +5.2V$. To operate in a mixed positive and negative supply environment, each of the supply voltages must be shifted up by 2.0V such that V_{TT} will now be GND, $V_{EE} = -3.2V$ and $V_{CC} = +2.0V$.

Bear in mind that termination voltages must be adjusted to reflect any shift in supply voltages.

VSC8161 Electrical Characteristics

Table 1: Multiplexer AC Characteristics (Over recommended operating range)

Parameter	Description	Min	Typ	Max	Units
t_D	CLK16 period	-	6.4	-	ns
t_{DSU}	Parallel data set-up time (wrt CLK16 falling edge)	1.7	-	-	ns
t_{DH}	Data hold time (wrt CLK16 falling edge)	0.3	-	-	ns
t_{DC}	CLK16 duty cycle	45	-	55	%
t_r t_f	REFCK+/- rise and fall times (10%-90%)	-	-	1.5	ns
t_r t_f	D(0..15)+/- rise and fall times (10%-90%)	-	-	2.0	ns
t_r t_f	CLK16+/- rise and fall times (10%-90%)	-	0.7	1	ns
t_{DINV}	Duration of Data Invalid Pulse	-	6.4	-	ns
t_{DV}	Parallel Data to DINVALID	-	$3t_D + 0.3ns$	-	ns

Figure 5: VSC8161 Parallel Interface AC Characteristics

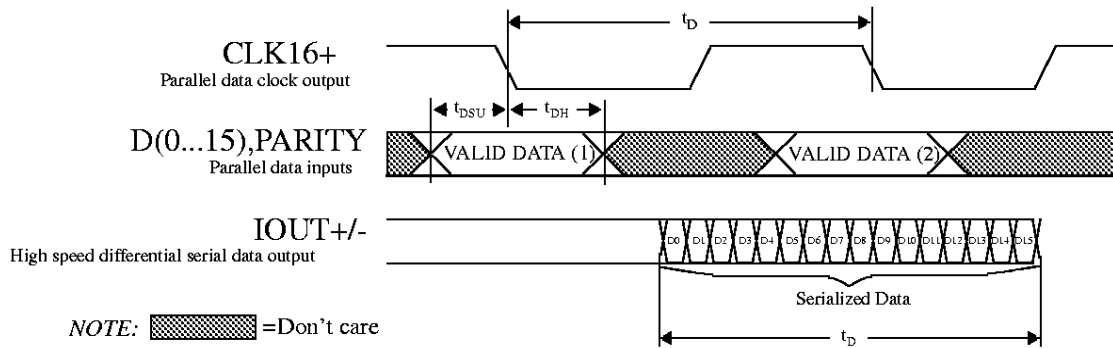
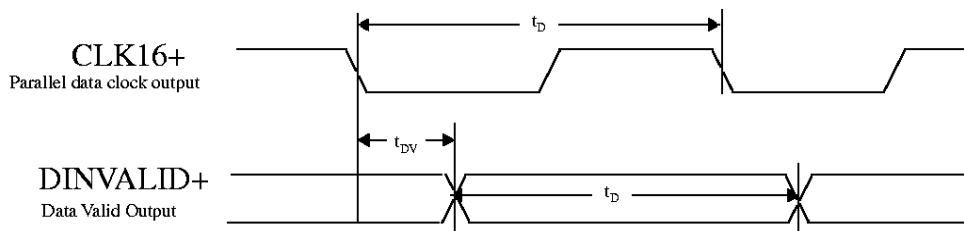

Figure 6: VSC8161 Parity Interface



Advance Product Information

VSC8161

2.488Gb/s SONET / SDH
16:1 Mux with Clock Generator and Laser Driver

Table 2: Low-speed Inputs and Outputs

Parameter	Description	Min	Typ	Max	Units	Conditions
V_{IH}	Input HIGH voltage	-1040	-	-600	mV	Guaranteed HIGH signal for all inputs
V_{IL}	Input LOW voltage	V_{TT}	-	-1600	mV	Guaranteed LOW signal for all inputs
$\Delta DIFF_{IN}$	Differential input voltage swing	0.400	0.800	1.4	V	AC coupled
$\Delta DIFF_{OUT}$	Differential output voltage swing	0.600	-	-	V	See Figure 7
ΔCM_{OUT}	Differential common mode output voltage		$V_{CC} - 1.2V$			See Figure 7

Figure 7: Differential Output Termination Methods

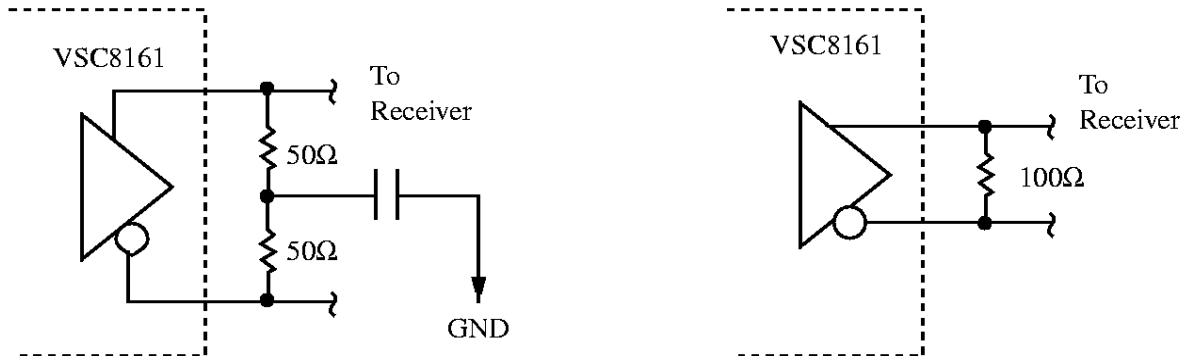

a) Two 50Ω resistors to a common AC ground

b) 100Ω pad-pad termination

Termination Method (a) is preferred for improved noise immunity.

Table 3: Clock Multiplier Unit Performance

Name	Description	Min	Typ	Max	Units
RC_d	Reference clock duty cycle	45		55	%
RC_f	Reference clock frequency		155.52		MHz
Δf_{RC}	Reference clock frequency range	-100		+100	ppm
t_{jitter}	Jitter generation (12 KHz to 20 MHz)			0.01	UI_{RMS}
g_{JT}	Jitter transfer peaking		1.0		dB
f_{-3dB}	Jitter transfer -3dB bandwidth		1800		kHz

Table 4: Laser Driver AC Electrical Specifications

Symbol	Parameter	Min	Typ	Max	Units	Conditions
t_r, t_f	Output Rise and Fall Times		100		ps	25 Ohm Load, 10%-90% 15 mA < I_{MOD} < 60 mA $I_{BIAS} = 40$ mA

Table 5: Laser Driver DC Electrical Specifications

Symbol	Parameter	Min	Typ	Max	Units	Conditions
I_{BIAS}	Programmable Laser Bias Current ^a			50	mA	
I_{MOD}	Programmable Modulation Current ^b			60	mA	
V_{IB}	Laser Bias Control Voltage			$V_{EE} + 2.1$	V	$I_{BIAS} = 50$ mA with 25Ω load
V_{IP}	Laser Modulation Control Voltage			$V_{EE} + 2.1$	V	$I_{MOD} = 60$ mA
V_{OCM}	Output Voltage Compliance	$V_{CC} - 2.5V$			V	$V_{EE} = -5.2V$

- a. I_{BIAS} will be less than 2mA when $(V_{IB} - M_{IB})$ is less than 100mV.
b. I_{MOD} will be less than 2mA when $(V_{IP} - M_{IP})$ is less than 100mV

Power Dissipation

Table 6: Power Supply Currents and Power Dissipation

Parameter	Description	Typ	Max	Units
I_{EE}	Power supply current from V_{EE} , max laser driver current	380	600	mA
I_{TT}	Power supply current from V_{TT} , max laser driver current	210	300	mA
P_D	Power dissipation, max laser driver current	2.5	3.9	W
P_D	Power dissipation, min laser driver current	2.0	3.3	W

Note: Over recommended operating conditions, $V_{CC} = GND$, outputs open-circuit)

Advance Product Information
VSC8161

2.488Gb/s SONET / SDH
 16:1 Mux with Clock Generator and Laser Driver

Absolute Maximum Ratings⁽¹⁾

Power Supply Voltage (V_{TT})	$V_{CC}-3.0V$ to $V_{CC}+0.5V$
Power Supply Voltage (V_{EE})	$V_{CC}-7.0V$ to $V_{CC} + 0.5V$
Input Voltage Applied (V_{VIN})	$V_{TT}-0.5V$ to $V_{CC}+0.5V$
Output Current, I_{OUT} (Modulation)	60 mA
Output Current, I_{OUT} (DC bias)	50 mA
Case Temperature Under Bias (T_C)	-55° to 125°C
Junction Temperature (T_j)	-55°C to + 125°C
Storage Temperature (T_{STG})	-65°C to +150°C

Notes: (1) Caution: Stresses listed under “Absolute Maximum Ratings” may be applied to devices one at a time without causing permanent damage. Functionality at or exceeding the values listed is not implied. Exposure to these values for extended periods may affect device reliability.

(2) V_{TT} must be applied before the magnitude of any input signal voltage ($|V_{IN}|$, $|V_{HSIN}|$) can be greater than $|V_{TT} - 0.5V|$

Recommended Operating Conditions

Power Supply Voltage (V_{TT})	-2.0V ±5 %
Power Supply Voltage (V_{EE})	-5.2V ±5 %
Commercial Operating Temperature Range* (T)	0° to 85°C

* Specification limits are based upon case temperature.

VSC8161 Package Pin Diagram

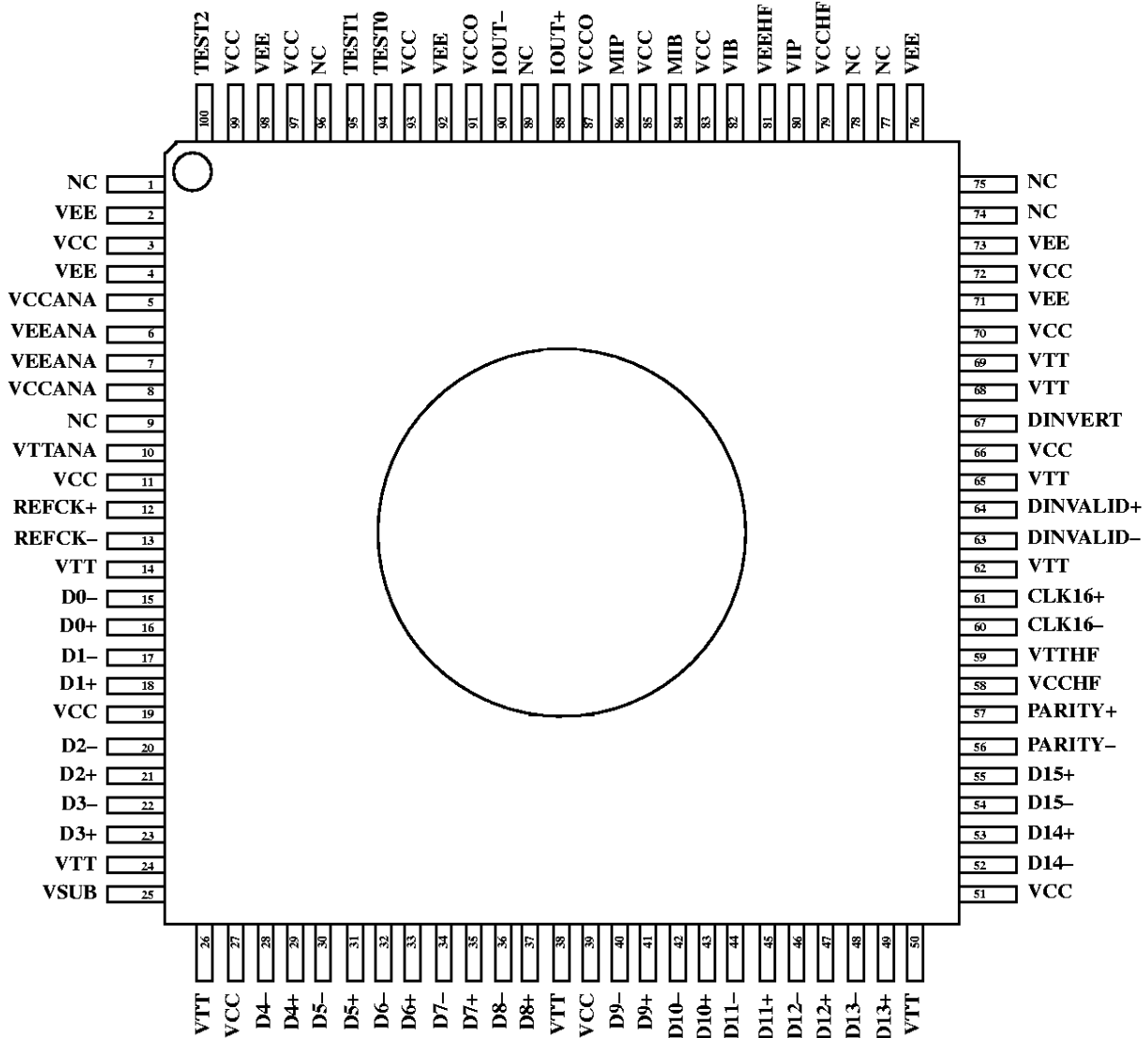

Advance Product Information
VSC8161

2.488Gb/s SONET / SDH
 16:1 Mux with Clock Generator and Laser Driver

Package Pin Description

Table 7: Pin Identification

<i>Signal Name</i>	<i>Pin #</i>	<i>I/O</i>	<i>Description</i>
NC	1	-	Do not connect, leave open
VEE	2	-	SCFL negative supply (-5.2V typ.)
VCC	3	-	Most positive supply (GND typ.)
VEE	4	-	SCFL negative supply (-5.2V typ.)
VCCANA	5	-	Most positive supply for analog circuits (GND typ.)
VEEANA	6	-	SCFL negative supply for analog circuits (-5.2 typ.)
VEEANA	7	-	SCFL negative supply for analog circuits (-5.2 typ.)
VCCANA	8	-	Most positive supply for analog circuits (GND typ.)
NC	9	-	Do not connect, leave open
VTTANA	10	-	DCFL negative supply for analog circuits (-2.0V typ.)
VCC	11	-	Most positive supply (GND typ.)
REFCK+	12	I	155 MHz Reference Clock (true)
REFCK-	13	I	155 MHz Reference Clock (complement)
VTT	14	-	DCFL negative supply (-2.0V typ.)
D0-	15	I	Low-speed Differential Parallel Data
D0+	16	I	Low-speed Differential Parallel Data
D1-	17	I	Low-speed Differential Parallel Data
D1+	18	I	Low-speed Differential Parallel Data
VCC	19	-	Most positive supply (GND typ.)
D2-	20	I	Low-speed Differential Parallel Data
D2+	21	I	Low-speed Differential Parallel Data
D3-	22	I	Low-speed Differential Parallel Data
D3+	23	I	Low-speed Differential Parallel Data
VTT	24	-	DCFL negative supply (-2.0V typ.)
VSUB	25	-	Substrate Voltage (connect to lowest supply voltage, i.e., VEE)
VTT	26	-	DCFL negative supply (-2.0V typ.)
VCC	27	-	Most positive supply (GND typ.)
D4-	28	I	Low-speed Differential Parallel Data
D4+	29	I	Low-speed Differential Parallel Data
D5-	30	I	Low-speed Differential Parallel Data
D5+	31	I	Low-speed Differential Parallel Data
D6-	32	I	Low-speed Differential Parallel Data
D6+	33	I	Low-speed Differential Parallel Data
D7-	34	I	Low-speed Differential Parallel Data
D7+	35	I	Low-speed Differential Parallel Data
D8-	36	I	Low-speed Differential Parallel Data

Signal Name	Pin #	I/O	Description
D8+	37	I	Low-speed Differential Parallel Data
VTT	38	-	DCFL negative supply (-2.0V typ.)
VCC	39	-	Most positive supply (GND typ.)
D9-	40	I	Low-speed Differential Parallel Data
D9+	41	I	Low-speed Differential Parallel Data
D10-	42	I	Low-speed Differential Parallel Data
D10+	43	I	Low-speed Differential Parallel Data
D11-	44	I	Low-speed Differential Parallel Data
D11+	45	I	Low-speed Differential Parallel Data
D12-	46	I	Low-speed Differential Parallel Data
D12+	47	I	Low-speed Differential Parallel Data
D13-	48	I	Low-speed Differential Parallel Data
D13+	49	I	Low-speed Differential Parallel Data
VTT	50	-	DCFL negative supply (-2.0V typ.)
VCC	51	-	Most positive supply (GND typ.)
D14-	52	I	Low-speed Differential Parallel Data
D14+	53	I	Low-speed Differential Parallel Data
D15-	54	I	Low-speed Differential Parallel Data
D15+	55	I	Low-speed Differential Parallel Data
PARITY-	56	I	Parity Bit (complement)
PARITY+	57	I	Parity Bit (true)
VCCHF	58	-	Most positive supply for high frequency outputs (GND typ.)
VTTHF	59	-	DCFL negative supply for high frequency outputs (-2.0V typ.)
CLK16-	60	O	Low-speed clock f = 155.52 MHz (complement)
CLK16+	61	O	Low-speed clock f = 155.52 MHz (true)
VTT	62	-	DCFL negative supply (-2.0V typ.)
DINVALID-	63	O	Data Not Valid (complement)
DINVALID+	64	O	Data Not Valid (true)
VTT	65	-	DCFL negative supply (-2.0V typ.)
VCC	66	-	Most positive supply (GND typ.)
DINVERT	67	I	Invert Data Output (Logic High = Invert)
VTT	68	-	DCFL negative supply (-2.0V typ.)
VTT	69	-	DCFL negative supply (-2.0V typ.)
VCC	70	-	Most positive supply (GND typ.)
VEE	71	-	SCFL negative supply (-5.2V typ.)
VCC	72	-	Most positive supply (GND typ.)
VEE	73	-	SCFL negative supply (-5.2V typ.)
NC	74	-	Do not connect, leave open
NC	75	-	Do not connect, leave open

Advance Product Information

VSC8161

2.488Gb/s SONET / SDH

16:1 Mux with Clock Generator and Laser Driver

<i>Signal Name</i>	<i>Pin #</i>	<i>I/O</i>	<i>Description</i>
VEE	76	-	SCFL negative supply (-5.2V typ.)
NC	77	-	Do not connect, leave open
NC	78	-	Do not connect, leave open
VCCHF	79	-	Most positive supply for high frequency outputs (GND typ.)
VIP	80	I	Laser Driver Modulation Current Control Node
VEEHF	81	-	SCFL negative supply for high frequency outputs (-5.2 typ.)
VIB	82	I	Laser Driver Bias Current Control Node
VCC	83	-	Ext. current return path for bias and modulation control (GND typ.)
MIB	84	-	Laser Driver Bias Current Source Monitor Node
VCC	85	-	Ext. current return path for bias and modulation control (GND typ.)
MIP	86	-	Laser Driver Modulation Current Source Monitor Node
VCCO	87	-	Ext. current return path for IOOUT+/- (GND typ.)
IOOUT+	88	O	High-speed Data Out (true)
NC	89	-	Do not connect, leave open
IOOUT-	90	O	High-speed Data Out (complement)
VCCO	91	-	Ext. current return path for IOOUT+/- (GND typ.)
VEE	92	-	SCFL negative supply (-5.2V typ.)
VCC	93	-	Most positive supply (GND typ.)
TEST0	94	-	Connect to most positive supply (GND typ.)
TEST1	95	-	Connect to most positive supply (GND typ.)
NC	96	-	Do not connect, leave open
VCC	97	-	Most positive supply (GND typ.)
VEE	98	-	SCFL negative supply (-5.2V typ.)
VCC	99	-	Most positive supply (GND typ.)
TEST2	100	-	Connect to most positive supply (GND typ.)

Table 8: Power Supply Summary

<i>Signal Name</i>	<i>Pin #</i>	<i>Description</i>
VEE	2,4,71,73,76,92,98	SCFL negative supply (-5.2V typ.)
VEEANA	6,7	SCFL negative supply for analog circuits (-5.2 typ.)
VEEHF	81	SCFL negative supply for high frequency outputs (-5.2 typ.)
VTT	14,24,26,38,50,62,65, 68,69	DCFL negative supply (-2.0V typ.)
VTTANA	10	DCFL negative supply for analog circuits (-2.0V typ.)
VTTHF	59	DCFL negative supply for high frequency outputs (-2.0V typ.)
VCC	3,11,19,27,39,51,66,70, 72,83,85,93,97,99	Most positive supply (GND typ.)
VCCANA	5,8	Most positive supply for analog circuits (GND typ.)
VCCHF	58,79	Most positive supply for high frequency outputs (GND typ.)
VCCO	87,91	Ext. current return path for IOUT+/- (GND typ.)
VSUB	25	Substrate Voltage (connect to lowest supply voltage, i.e., VEE)
TEST[0:2]	94,95,100	Connect to most positive supply (GND typ.)

All supplies which reference the same voltage may be connected to the same power supply plane. The VCCANA, VTTANA, and VEEANA are noise sensitive supplies, while the VCCHF, VCCO, VTTHF, and VEEHF are noise generating supplies. Appropriate power supply noise suppression should be applied to optimize the performance of the device.

Advance Product Information

VSC8161

2.488Gb/s SONET / SDH
16:1 Mux with Clock Generator and Laser Driver

Package Information

100 PQFP: (14 x 14 x 2.0 mm) Package Drawing (Top View)
Body +3.2mm Footprint

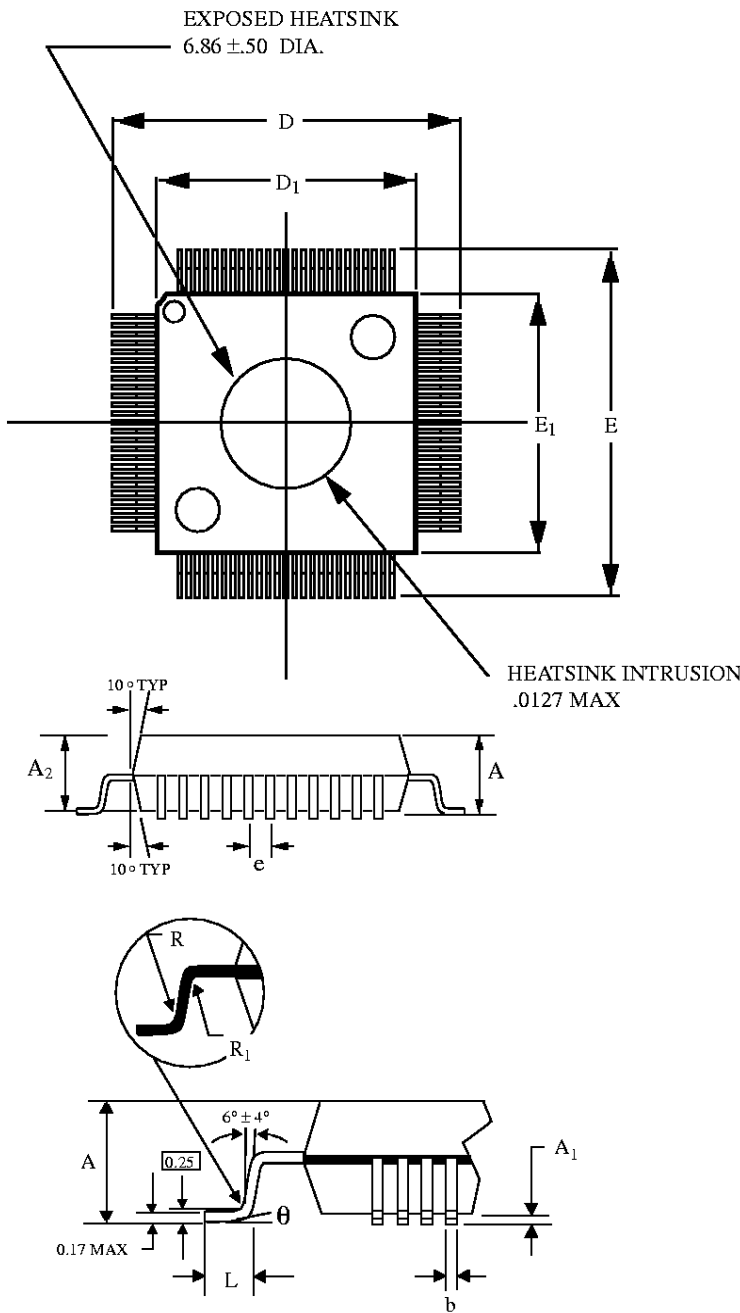

Key	mm	Tolerance
A	2.35	MAX
A1	0.25	MAX
A2	2.00	+ .10 / -.05
D	17.20	±.25
D1	14.00	±.10
E	17.20	±.25
E1	14.00	±.10
L	.88	+ .15 / -.10
e	.50	BASIC
b	.22	±.05
θ	0°-7°	
R	.30	TYP
R1	.20	TYP

NOTES:
(1) Drawings not to scale.
(2) All units in millimeters unless otherwise noted
Package #: 101-318-3
Issue #: 2

Notice

This document contains information about a product during its fabrication or early sampling phase of development. The information contained in this document is based on design targets, simulation results or early prototype test results. Characteristic data and other specifications are subject to change without notice. Therefore the reader is cautioned to confirm that this datasheet is current prior to design or order placement.

Warning

Vitesse Semiconductor Corporation's product are not intended for use in life support appliances, devices or systems. Use of a Vitesse product in such applications without written consent is prohibited.