

# TSL215 128 × 1 INTEGRATED OPTO SENSOR

SOES005A – JUNE 1992 – REVISED AUGUST 1993

- Contains Two 64-Bit Static Shift Registers
- Offers Extendable Data I/O for Expanding the Number of Sensors
- Contains Analog Buffer With Sample-and-Hold for Analog Output Over Full Clock Period
- Single-Supply Operation
- Operates With 500-kHz Shift Clock
- 14-Pin Encapsulated Clear Plastic Package
- Advanced LinCMOS™ Technology

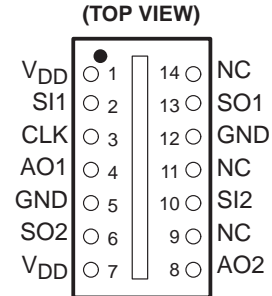

NC – No internal connection

## description

The TSL215 integrated opto sensor consists of two sections of 64 charge-mode pixels arranged in a 128 × 1 linear array. Each pixel measures 120 μm × 70 μm with 125-μm center-to-center spacing. Operation is simplified by internal logic requiring only clock and start-integration-pulse signals.

The TSL215 is intended for use in a wide variety of applications including linear and rotary encoding, bar-code reading, edge detection and positioning, and contact imaging.

The TSL215 is supplied in a 14-pin dual-in-line clear plastic package.



Caution. These devices have limited built-in gate protection. The leads should be shorted together or the device placed in conductive foam during storage or handling to prevent electrostatic damage to the MOS gates.

Advanced LinCMOS is a trademark of Texas Instruments Incorporated.

PRODUCTION DATA information is current as of publication date. Products conform to specifications per the terms of Texas Instruments standard warranty. Production processing does not necessarily include testing of all parameters.

 **TEXAS  
INSTRUMENTS**

POST OFFICE BOX 655303 • DALLAS, TEXAS 75265

Copyright © 1993, Texas Instruments Incorporated

# TSL215

## 128 × 1 INTEGRATED OPTO SENSOR

SOES005A – JUNE 1992 – REVISED AUGUST 1993

### functional block diagram of each section

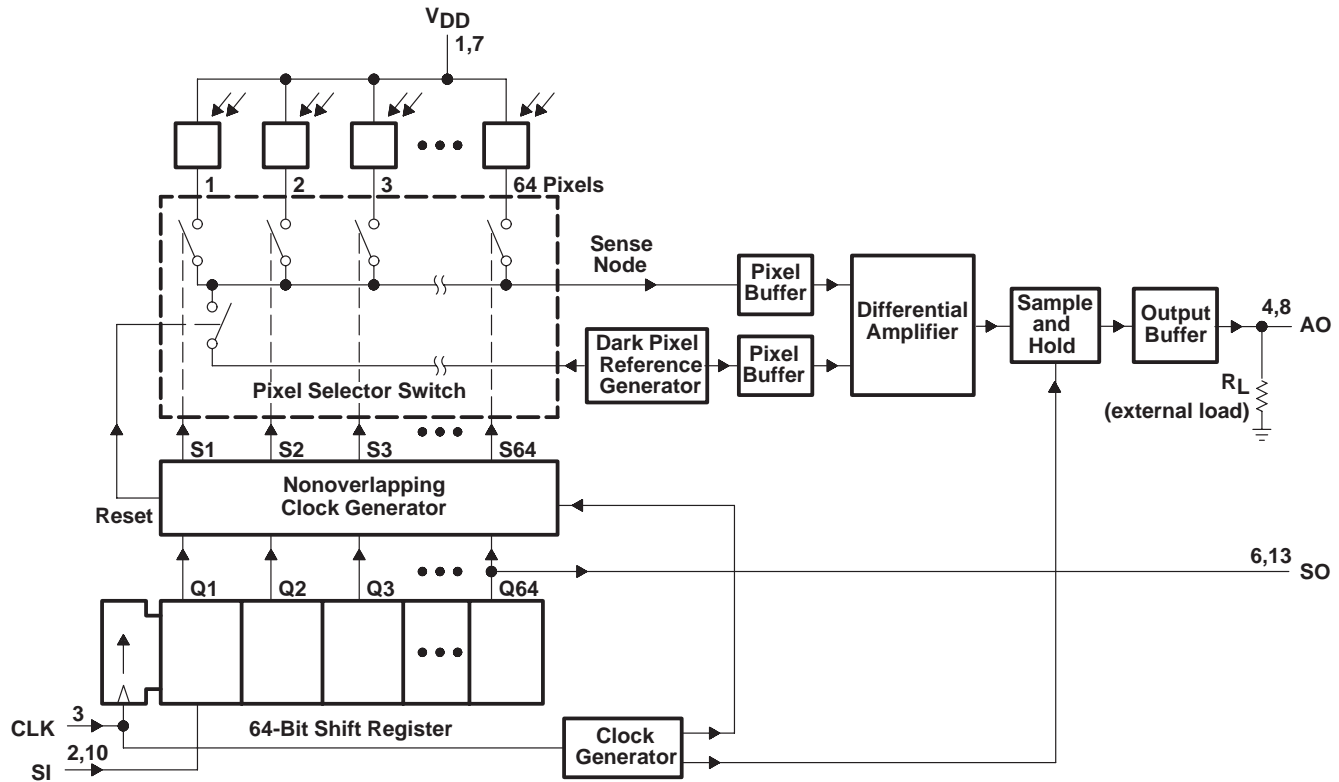

### Terminal Functions

PIN NAME	PIN NO.	DESCRIPTION
AO1	4	Analog output of section 1
AO2	8	Analog output of section 2
CLK	3	Clock. The clock controls charge transfer, pixel output, and reset.
GND	5, 12	Ground (substrate). All voltages are referenced to the substrate.
NC	9, 11, 14	No internal connection
SI1	2	Serial input (section 1). The serial input defines the end of the integration period and initiates the pixel output sequence.
SI2	10	Serial input (section 2). The serial input defines the end of the integration period and initiates the pixel output sequence.
SO1	13	Serial output (section 1). The serial output provides a signal to drive the SI2 input.
SO2	6	Serial output (section 2). The serial output provides a signal to drive the SI1 input of another TSL215 sensor for cascading.
VDD	1, 7	Supply voltage. These supply power to the analog and digital circuits.

---

## detailed description

### sensor elements

The line of sensor elements, called pixels, consists of 128 discrete photosensing areas. Light energy striking a pixel generates electron-hole pairs in the region under the pixel. The field generated by the bias on the pixel causes the electrons to collect in the element while the holes are swept into the substrate. The amount of charge accumulated in each element is directly proportional to the amount of incident light and the integration time.

### device operation

Operation of the 128 × 1 array sensor is a function of two time periods: an integration period during which a charge is accumulated in the pixels and an output period during which signals are transferred to the output. The integration period is defined by the interval between the externally supplied (SI) pulses and includes the output period (see Figure 1). The required length of the integration period depends on the amount of incident light and the desired output signal level. A single TSL215 can be connected in either a serial or parallel configuration.

### serial configuration

The serial connection shown in Figure 1 is accomplished by connecting the analog outputs (AO1 and AO2) together and connecting the SO1 output to the SI2 input. As shown in Figure 1, the external SI signal is supplied to only the SI1 input. This causes the first section of 64 pixels to be clocked out in synchronization with CLK. In conjunction with the 64th pixel, the SI pulse is shifted out on the SO1 output. This SO1 pulse is then fed to the SI2 input. The 65th clock cycle terminates the output of the last pixel from the first section and clears the shift register of that section in preparation for the next SI pulse to that section. The rising edge of the 65th cycle also puts AO1 into the high-impedance state. The appearance of the SI2 signal and the 65th clock cycle initiates the output cycle of the second section. The second section of 64 pixels appears at AO2, and the SO2 signal is shifted out on the 128th clock cycle. The rising edge of the 129th clock cycle resets the second section and puts AO2 into the high-impedance state. Both AO1 and AO2 remain in this high-impedance state until a new external SI pulse appears on SI1. When the TSL215 is connected as shown in Figure 1, the analog output appears as a continuous string representing the 128 pixels.

### parallel configuration

Parallel operation of the TSL215 (see Figure 2) is accomplished by connecting the serial input lines (SI1 and SI2) together and connecting each AO line (AO1 and AO2) to its own load resistor ( $R_L$ ). This supplies the external serial input pulse to both SI1 and SI2 simultaneously. Each AO line must be independent of the other line since both sections are active simultaneously. Pixels 1 through 64 appear on AO1, while pixels 65 through 128 appear on AO2. These two sections of 64 pixels begin clocking out concurrently, each on its respective output. On the 64th clock cycle, both SO1 and SO2 are shifted out of each respective register. The rising edge of the 65th cycle terminates the output of the 64th pixel from each section and also resets both section's shift registers. Both AO lines then go to the high-impedance state until the next external SI signal appears.

### sense node

On completion of the integration period, the charge contained in each pixel is transferred in turn to the sense node under the control of the clock (CLK) and serial-input (SI) signals. The signal voltage generated at this node is directly proportional to the amount of charge and inversely proportional to the capacitance of the sense node.

### reset

An internal reset signal is generated by the nonoverlapping clock generator (NOCG) and occurs every clock cycle. Reset establishes a known voltage on the sense node in preparation for the next charge transfer. This voltage is used as a reference level for the differential signal amplifier.

# TSL215

## 128 × 1 INTEGRATED OPTO SENSOR

SOES005A – JUNE 1992 – REVISED AUGUST 1993

---

### detailed description (continued)

#### shift register

Both 64-bit shift registers control the transfer of charge from the pixels to the output stages and provide timing signals for the NOCG. The serial input (SI) signal provides the input to the shift register and is shifted under direct control of CLK out to the serial output (SO) on the 64th clock cycle. This SO pulse can then be used as the SI pulse for the next section or next device.

The output period for each section is initiated by the presence of the SI input pulse coincident with a rising edge of CLK (see Figures 1, 2, and 3). The analog output voltage corresponds to the level of the first pixel after settling time ( $t_s$ ) and remains constant for a minimum time ( $t_v$ ). A voltage corresponding to each succeeding pixel is available at each rising edge of CLK. The output period of a section ends when the active section sees the rising edge of the 65th clock cycle, at which time the output assumes the high-impedance state. Once the output period has been initiated by an SI pulse, CLK must be allowed to complete  $[(n \times 64) + 1]$  (where  $n$  is the number of sections running in series) positive-going transitions in order to reset the internal logic to a known state. To achieve minimum integration time, the SI pulse may be present on the  $[(n \times 64) + 2]$  rising clock to immediately restart the output phase.

#### sample-and-hold

The sample-and-hold signal generated by the NOCG is used to hold the analog output voltage of each pixel constant until the next pixel is clocked out. The signal is sampled while CLK is high and held constant while CLK is low.

#### nonoverlapping clock generators

The NOCG circuitry provides internal control signals for the sensor, including reset and pixel-charge sensing. The signals are synchronous and are controlled by the outputs of the shift register.

#### initialization

Initialization of the sensor elements may be necessary on power up or during operation after any period of CLK or SI inactivity exceeding the integration time. The initialization phase consists of 12 to 15 consecutively performed output cycles and clears the pixels of any charge that may have accumulated during the inactive period.

#### multiple-unit operation

Multiple-sensor devices can be connected together in a serial or parallel configuration. The serial connection is accomplished by connecting analog outputs (AO) together and connecting the SO output of each sensor device to the SI input of the next device. The SI signal is applied to only the first device. Each succeeding device receives its SI input from the SO output of the preceding device. For  $m$ -cascaded devices, the SI pulse is applied to the first device after every  $m \cdot 128$ th positive-going CLK transitions. A common clock signal is applied to all the devices simultaneously. Parallel operation of multiple devices is accomplished by supplying CLK and SI signals to all the devices simultaneously. The output of each device is then separately used for processing.

#### output enable

The internally generated output-enable signal enables the output stage of each section during the output period (64 clock cycles). During the remainder of the integration period, the output stage is in the high-impedance state that allows output interconnections of multiple devices without interference.



**absolute maximum ratings,  $T_A = 25^\circ\text{C}$  (unless otherwise noted) (see Note 1)†**

Supply voltage range, $V_{DD}$ (see Note 1)	–0.5 V to 7 V
Digital output voltage range, $V_O$	–0.5 V to $V_{DD} + 0.5$ V
Digital output current, $I_O$	3 mA
Digital input current range, $I_I$	–20 mA to 20 mA
Operating case temperature range, $T_C$ (see Note 2)	–10°C to 85°C
Storage temperature range	–25°C to 85°C
Lead temperature 1,6 mm (1/16 inch) from case for 10 seconds	260°C

† Stresses beyond those listed under absolute maximum ratings may cause permanent damage to the device. These are stress ratings only, and functional operation of the device at these or any other conditions beyond those indicated under “recommended operating conditions” is not implied. Exposure to absolute-maximum-rated conditions for extended periods may affect device reliability.

- NOTES: 1. Voltage values are with respect to the network GND.  
2. Case temperature is the surface temperature of the plastic measured directly over the integrated circuit.

**recommended operating conditions**

	MIN	NOM	MAX	UNIT
Supply voltage, $V_{DD}$	4.5		5.5	V
Input voltage, $V_I$	0		$V_{DD}$	V
High-level input voltage, $V_{IH}$	$V_{DD} \times 0.7$		$V_{DD}$	V
Low-level input voltage, $V_{IL}$	0		$V_{DD} \times 0.3$	V
Analog output external resistive load, $R_L$		330		$\Omega$
Wavelength of light source, $\lambda$		750		nm
Clock input frequency, $f_{clock}$	10		500	kHz
Pulse duration, CLK low, $t_w(\text{CLKL})$	1			$\mu\text{s}$
Sensor integration time, $t_{int}$ (see Figures 1 and 2)		5		ms
Setup time, SI before $\text{CLK}\uparrow$ , $t_{su}(\text{SI})$	50			ns
Hold time, SI after $\text{CLK}\uparrow$ , $t_h(\text{SI})$	50			ns
Total number of TSL215 outputs connected together			8	
Operating free-air temperature, $T_A$	0		70	$^\circ\text{C}$

# TSL215

## 128 × 1 INTEGRATED OPTO SENSOR

SOES005A – JUNE 1992 – REVISED AUGUST 1993

**electrical characteristics,  $V_{DD} = 5\text{ V}$ ,  $T_A = 25^\circ\text{C}$ ,  $f_{\text{clock}} = 180\text{ kHz}$ ,  $\lambda_p = 565\text{ nm}$ ,  $R_L = 330\ \Omega$ ,  $C_L = 330\text{ pF}$ ,  $t_{\text{int}} = 5\text{ ms}$ ,  $E_e = 20\ \mu\text{W}/\text{cm}^2$  (unless otherwise noted) (see Note 3)**

PARAMETER	TEST CONDITIONS	MIN	TYP†	MAX	UNIT
Low-level output voltage	$I_O = 0$			0.1	V
High-level output voltage		4.4			V
Analog output voltage, saturation level	$E_e = 60\ \mu\text{W}/\text{cm}^2$	3	3.4		V
Analog output voltage (white, average over 64 pixels)		1.75	2.2		V
Analog output voltage (dark, each pixel)	$E_e = 0$		0.25	0.4	V
Output voltage (white) change with change in $V_{DD}$	$V_{DD} = 5\text{ V} \pm 5\%$ , See Note 4		$\pm 2\%$		
Dispersion of analog output voltage	See Note 5			$\pm 10\%$	
Linearity of analog output voltage	$t_{\text{int}} = 2\text{ ms to } 5\text{ ms}$ , See Note 6	0.85		1.15	
Pixel recovery time	See Note 7		25	40	ms
Supply current	$I_{DD}$ (average), See Note 4		4	12	mA
High-level input current	$V_I = V_{DD}$			0.5	$\mu\text{A}$
Low-level input current	$V_I = 0$			0.5	$\mu\text{A}$
Input capacitance			5		pF

† All typical values are at  $V_{DD} = 5\text{ V}$  and  $T_A = 25^\circ\text{C}$ .

NOTES: 3. The input irradiance ( $E_e$ ) is supplied by an LED array with  $\lambda_p = 565\text{ nm}$ .

4. Device tested in parallel mode with only one section active

5. Dispersion of analog output voltage is the maximum difference between the voltage from any single pixel and the average output voltage from all pixels of the device under test.

6. Linearity of analog output voltage is calculated by averaging over 64 pixels and measuring the maximum deviation of the voltage at 2 ms and 3.5 ms from a line drawn between the voltage at 2.5 ms and 5 ms.

7. Pixel recovery time is the time required for a pixel to go from the analog-output-voltage (white, average over 64 pixels) level to analog-output-voltage (dark, each pixel) level or vice versa after a step change in light input.

**operating characteristics,  $R_L = 330\ \Omega$ ,  $C_L = 330\text{ pF}$ ,  $V_{DD} = 5\text{ V}$ ,  $T_A = 25^\circ\text{C}$ ,  $t_{\text{int}} = 5\text{ ms}$ ,  $E_e = 20\ \mu\text{W}/\text{cm}^2$ ,  $f_{\text{clock}} = 500\text{ kHz}$  (unless otherwise noted)**

PARAMETER	TEST CONDITIONS	MIN	TYP	MAX	UNIT	
$t_r(\text{SO})$ Rise time, SO	See Figure 3 and Note 8		25		ns	
$t_f(\text{SO})$ Fall time, SO			25		ns	
$t_{pd}(\text{SO})$ Propagation delay time, SO				70		ns
$t_s$ Settling time				1		$\mu\text{s}$
$t_v$ Valid time				$1/2 f_{\text{clock}}$		$\mu\text{s}$

NOTE 8: Clock duty cycle is assumed to be 50%.

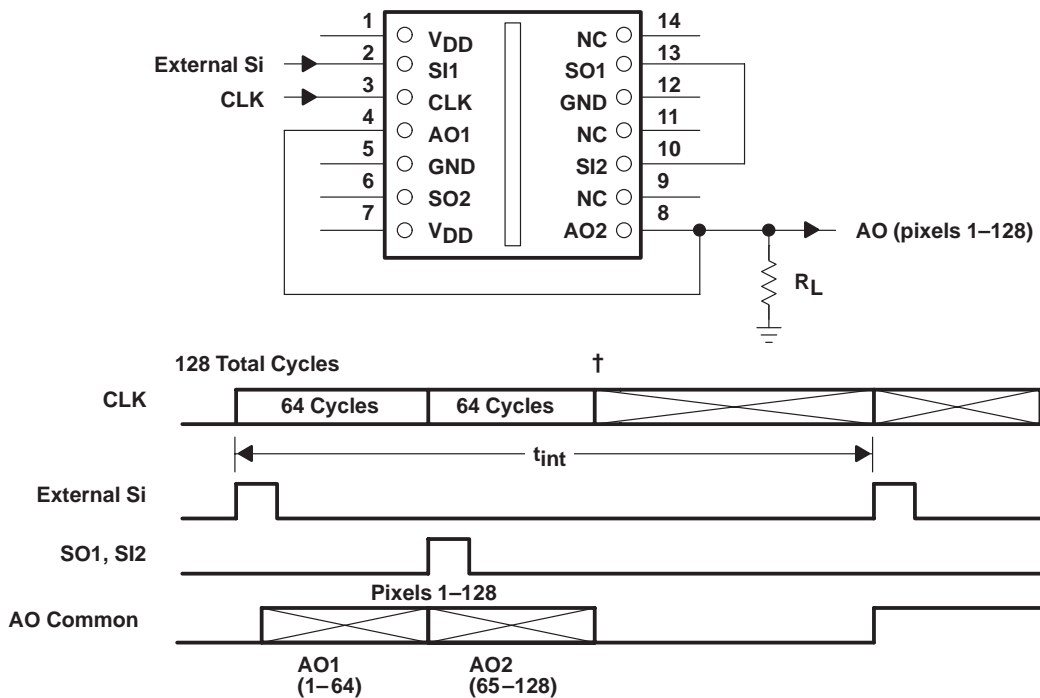

† CLK continues or goes low after 129 cycles.

Figure 1. Serial Configuration

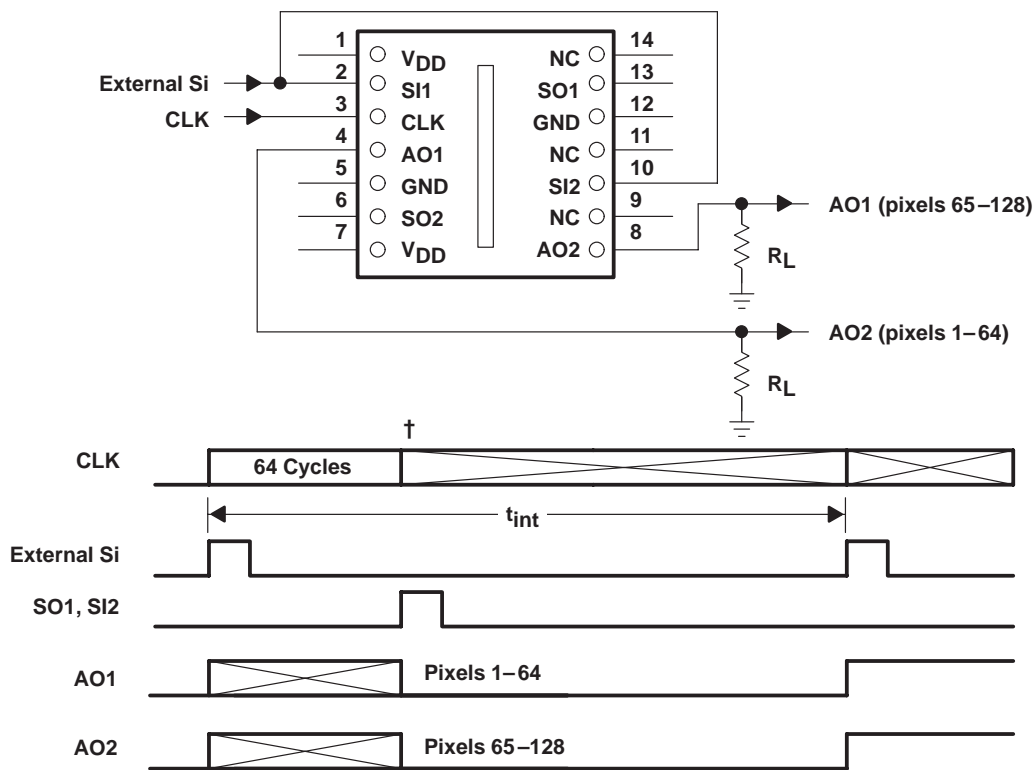

† CLK continues or goes low after 65 cycles.

Figure 2. Parallel Configuration

# TSL215 128 × 1 INTEGRATED OPTO SENSOR

SOES005A – JUNE 1992 – REVISED AUGUST 1993

## PARAMETER MEASUREMENT INFORMATION

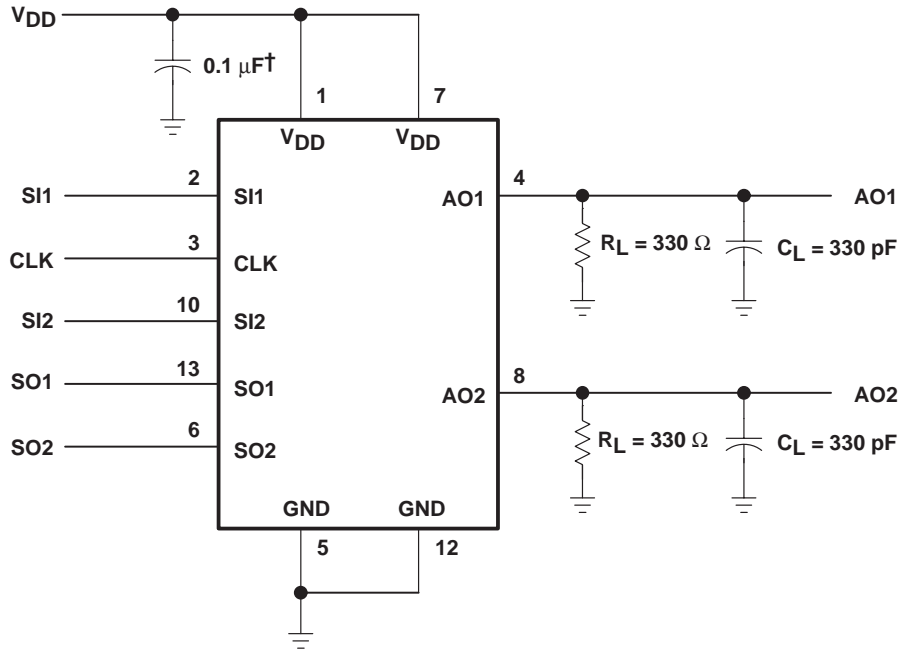

† Supply bypass capacitor with short leads should be placed as close to the device as possible.

### TEST CIRCUIT

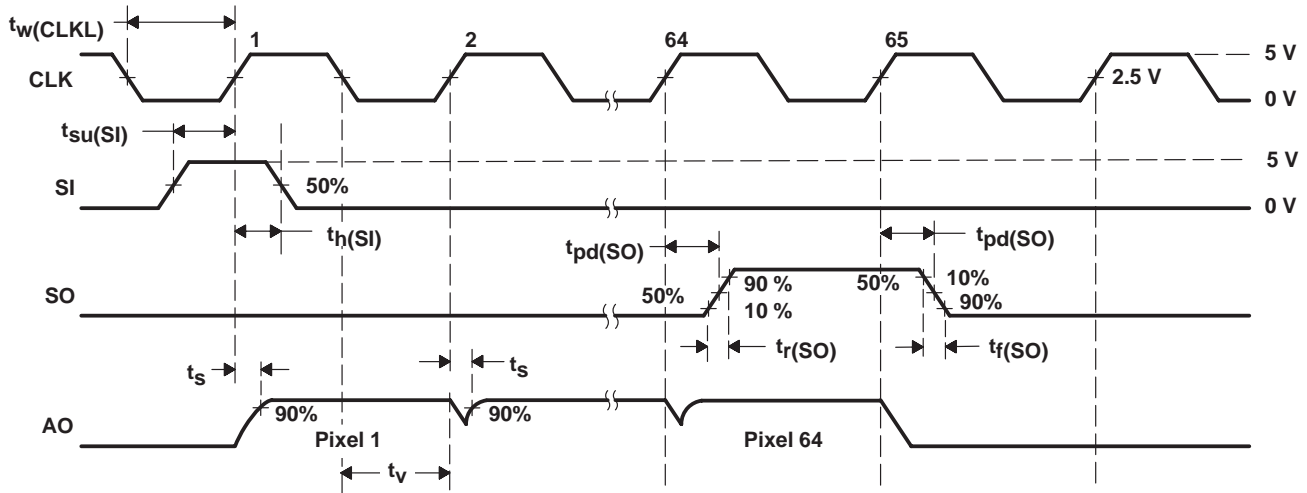

### OPERATIONAL WAVEFORMS

Figure 3. Test Circuit and Operational Waveforms

TYPICAL CHARACTERISTICS

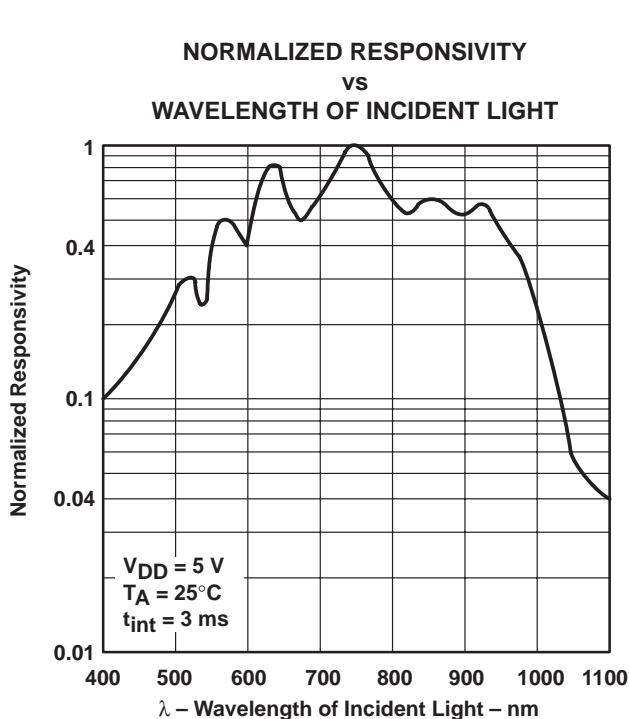

Figure 4

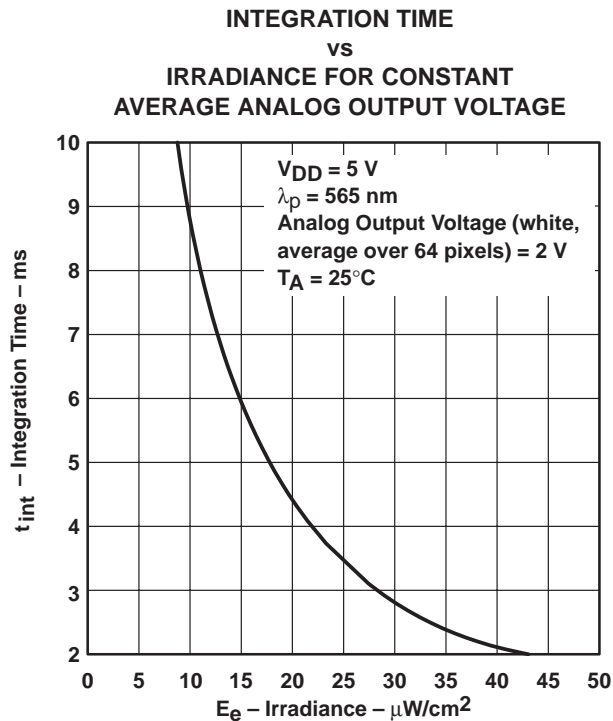

Figure 5

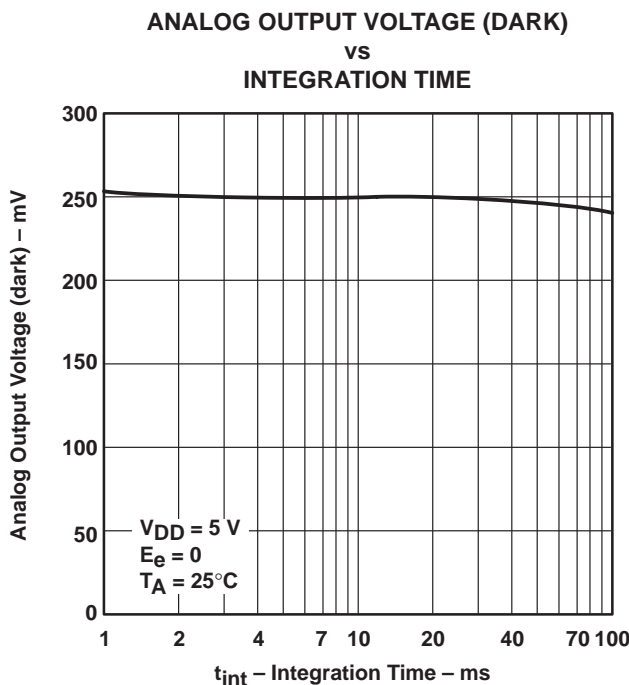

Figure 6

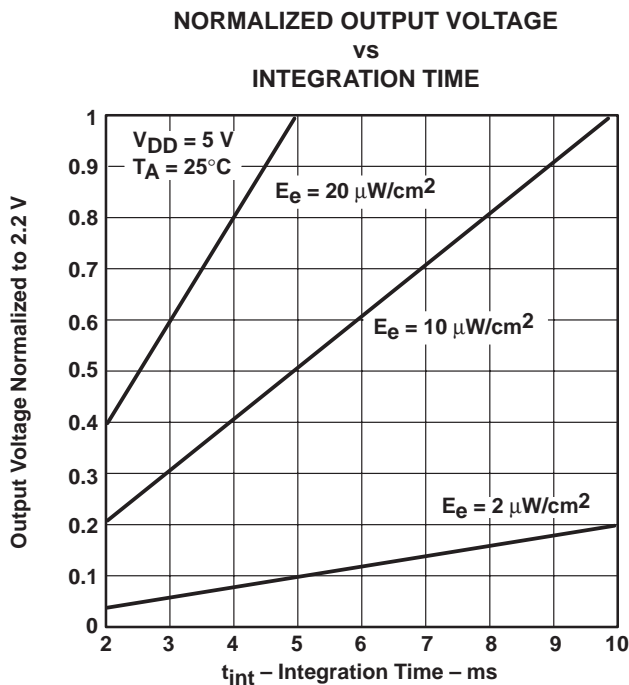

Figure 7

# TSL215

## 128 × 1 INTEGRATED OPTO SENSOR

SOES005A – JUNE 1992 – REVISED AUGUST 1993

### MECHANICAL DATA

This assembly consists of a sensor chip mounted on a printed-circuit board in a clear molded plastic package. The distance between the top surface of the package and the surface of the sensor is nominally 1 mm (0.040 inch).

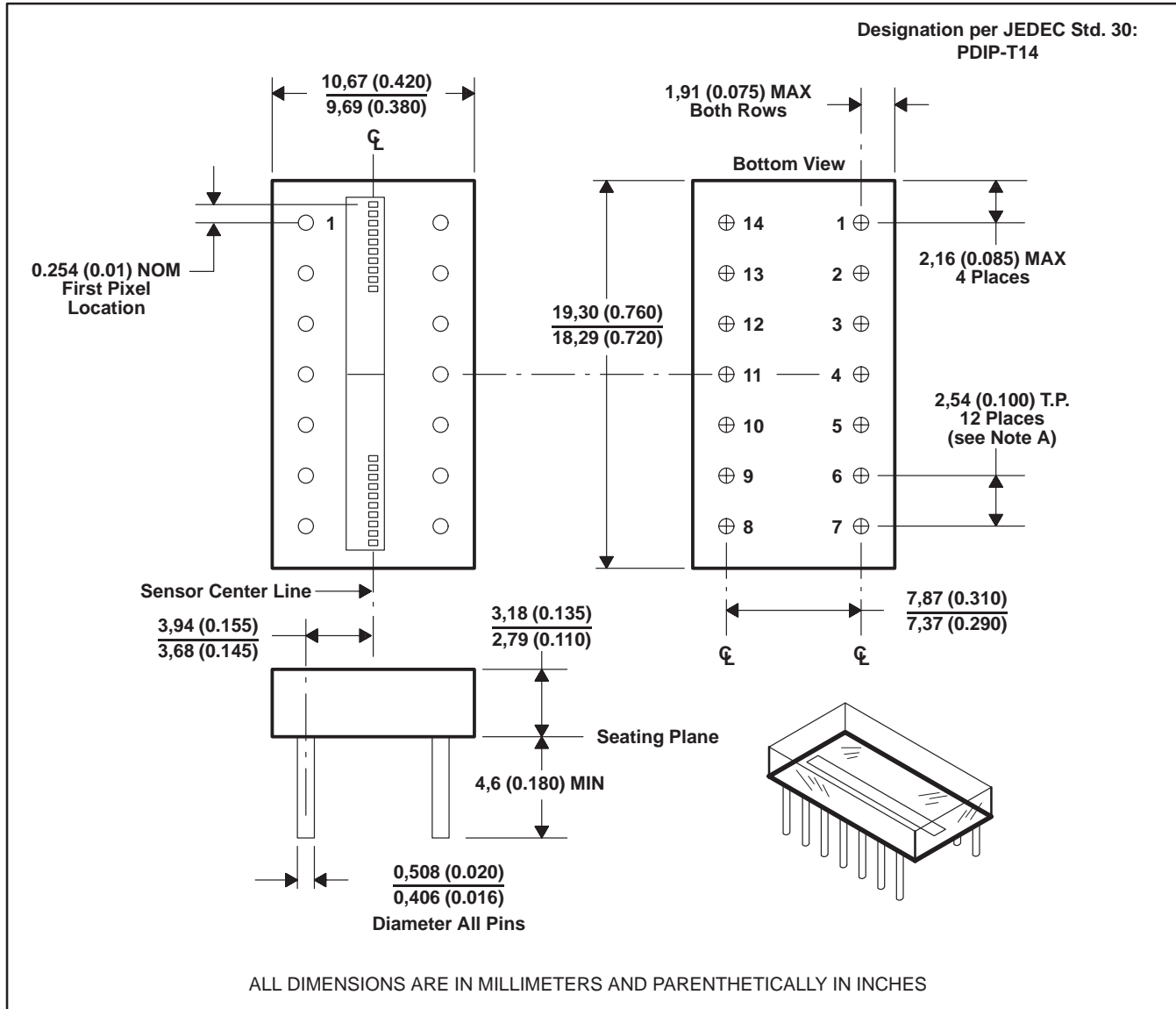

NOTE A: The true-position spacing is 2,54 mm (0.100 inch) between lead centerlines. Each pin centerline is located within 0,25 mm (0.010 inch) of its true longitudinal positions.

**PACKAGING INFORMATION**

Orderable Device	Status <sup>(1)</sup>	Package Type	Package Drawing	Pins	Package Qty	Eco Plan <sup>(2)</sup>	Lead/Ball Finish	MSL Peak Temp <sup>(3)</sup>
TSL215	OBSOLETE	XCEPT	COB	14		TBD	Call TI	Call TI

<sup>(1)</sup> The marketing status values are defined as follows:

**ACTIVE:** Product device recommended for new designs.

**LIFEBUY:** TI has announced that the device will be discontinued, and a lifetime-buy period is in effect.

**NRND:** Not recommended for new designs. Device is in production to support existing customers, but TI does not recommend using this part in a new design.

**PREVIEW:** Device has been announced but is not in production. Samples may or may not be available.

**OBSOLETE:** TI has discontinued the production of the device.

<sup>(2)</sup> Eco Plan - The planned eco-friendly classification: Pb-Free (RoHS) or Green (RoHS & no Sb/Br) - please check <http://www.ti.com/productcontent> for the latest availability information and additional product content details.

**TBD:** The Pb-Free/Green conversion plan has not been defined.

**Pb-Free (RoHS):** TI's terms "Lead-Free" or "Pb-Free" mean semiconductor products that are compatible with the current RoHS requirements for all 6 substances, including the requirement that lead not exceed 0.1% by weight in homogeneous materials. Where designed to be soldered at high temperatures, TI Pb-Free products are suitable for use in specified lead-free processes.

**Green (RoHS & no Sb/Br):** TI defines "Green" to mean Pb-Free (RoHS compatible), and free of Bromine (Br) and Antimony (Sb) based flame retardants (Br or Sb do not exceed 0.1% by weight in homogeneous material)

<sup>(3)</sup> MSL, Peak Temp. -- The Moisture Sensitivity Level rating according to the JEDEC industry standard classifications, and peak solder temperature.

**Important Information and Disclaimer:**The information provided on this page represents TI's knowledge and belief as of the date that it is provided. TI bases its knowledge and belief on information provided by third parties, and makes no representation or warranty as to the accuracy of such information. Efforts are underway to better integrate information from third parties. TI has taken and continues to take reasonable steps to provide representative and accurate information but may not have conducted destructive testing or chemical analysis on incoming materials and chemicals. TI and TI suppliers consider certain information to be proprietary, and thus CAS numbers and other limited information may not be available for release.

In no event shall TI's liability arising out of such information exceed the total purchase price of the TI part(s) at issue in this document sold by TI to Customer on an annual basis.

## IMPORTANT NOTICE

Texas Instruments Incorporated and its subsidiaries (TI) reserve the right to make corrections, modifications, enhancements, improvements, and other changes to its products and services at any time and to discontinue any product or service without notice. Customers should obtain the latest relevant information before placing orders and should verify that such information is current and complete. All products are sold subject to TI's terms and conditions of sale supplied at the time of order acknowledgment.

TI warrants performance of its hardware products to the specifications applicable at the time of sale in accordance with TI's standard warranty. Testing and other quality control techniques are used to the extent TI deems necessary to support this warranty. Except where mandated by government requirements, testing of all parameters of each product is not necessarily performed.

TI assumes no liability for applications assistance or customer product design. Customers are responsible for their products and applications using TI components. To minimize the risks associated with customer products and applications, customers should provide adequate design and operating safeguards.

TI does not warrant or represent that any license, either express or implied, is granted under any TI patent right, copyright, mask work right, or other TI intellectual property right relating to any combination, machine, or process in which TI products or services are used. Information published by TI regarding third-party products or services does not constitute a license from TI to use such products or services or a warranty or endorsement thereof. Use of such information may require a license from a third party under the patents or other intellectual property of the third party, or a license from TI under the patents or other intellectual property of TI.

Reproduction of information in TI data books or data sheets is permissible only if reproduction is without alteration and is accompanied by all associated warranties, conditions, limitations, and notices. Reproduction of this information with alteration is an unfair and deceptive business practice. TI is not responsible or liable for such altered documentation.

Resale of TI products or services with statements different from or beyond the parameters stated by TI for that product or service voids all express and any implied warranties for the associated TI product or service and is an unfair and deceptive business practice. TI is not responsible or liable for any such statements.

Following are URLs where you can obtain information on other Texas Instruments products and application solutions:

<b>Products</b>		<b>Applications</b>	
Amplifiers	<a href="http://amplifier.ti.com">amplifier.ti.com</a>	Audio	<a href="http://www.ti.com/audio">www.ti.com/audio</a>
Data Converters	<a href="http://dataconverter.ti.com">dataconverter.ti.com</a>	Automotive	<a href="http://www.ti.com/automotive">www.ti.com/automotive</a>
DSP	<a href="http://dsp.ti.com">dsp.ti.com</a>	Broadband	<a href="http://www.ti.com/broadband">www.ti.com/broadband</a>
Interface	<a href="http://interface.ti.com">interface.ti.com</a>	Digital Control	<a href="http://www.ti.com/digitalcontrol">www.ti.com/digitalcontrol</a>
Logic	<a href="http://logic.ti.com">logic.ti.com</a>	Military	<a href="http://www.ti.com/military">www.ti.com/military</a>
Power Mgmt	<a href="http://power.ti.com">power.ti.com</a>	Optical Networking	<a href="http://www.ti.com/opticalnetwork">www.ti.com/opticalnetwork</a>
Microcontrollers	<a href="http://microcontroller.ti.com">microcontroller.ti.com</a>	Security	<a href="http://www.ti.com/security">www.ti.com/security</a>
		Telephony	<a href="http://www.ti.com/telephony">www.ti.com/telephony</a>
		Video & Imaging	<a href="http://www.ti.com/video">www.ti.com/video</a>
		Wireless	<a href="http://www.ti.com/wireless">www.ti.com/wireless</a>

Mailing Address: Texas Instruments  
Post Office Box 655303 Dallas, Texas 75265