

This document is the property of Amphenol Corporation and is delivered on the express condition that it is not to be disclosed, reproduced or used, in whole or in part, for manufacture or sale by anyone other than Amphenol Corporation without its prior consent, and that no right is granted to disclose or to use any information in this document.

* THIS PRODUCT DIDN'T HAVE ENVIRONMENT- RELATED SUBSTANCES PER MATERIALS SPECIFICATION #MS-S001, LEVEL 1. WHEN THE TIME SET SCHEDULE OF LEVEL 2 IS EXPIRY, THE SUBSTANCES SHALL NOT BE CONTAINED WITH THIS PRODUCT.

MFG CODE: VEDAL1

CUSTOMER DRAWING

ORIGINAL

REVISIONS				
SYM	ECN No.	DESCRIPTION	DATE	APPROVED
A		RELEASE TO PRODUCTION	11/17/2004	Bodhi Chih

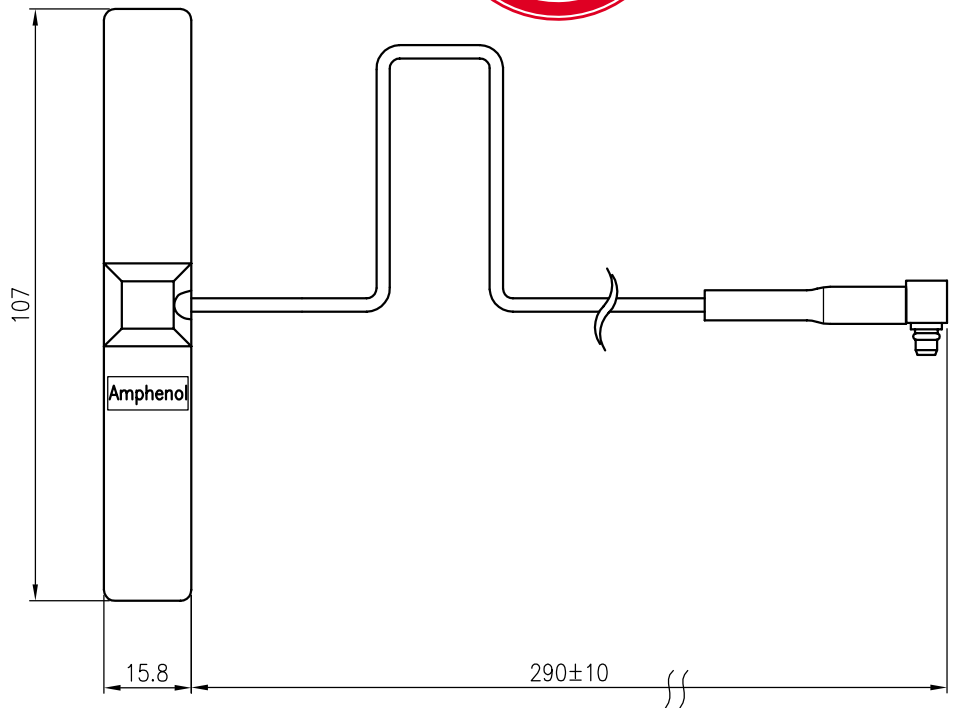
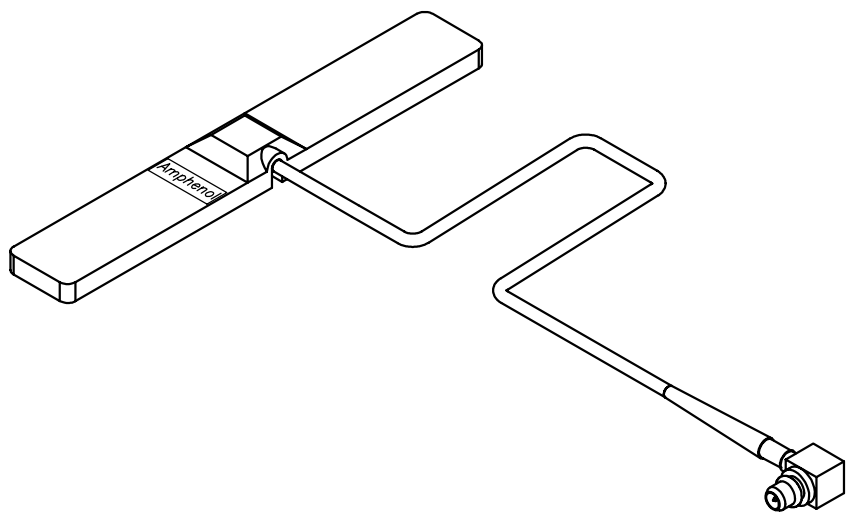

NOTES:

- BODY: BRASS, GOLD PLATED
CONTACT: BERYLLIUM COPPER, 30u" GOLD PLATED
INSULATION: TEFLON / NATURE
COVER: BRASS, GOLD PLATED
- CABLE: RG174U COAXIAL CABLE, COLOR- BLACK
- CONNECTOR: MMCX, R/A PLUG CONNECTOR
- SURFACE CLEANER: 3M VHB
- TAPER: PE FOAM

ELECTRICAL SPEC:

- IMPEDANCE: 50 OHMS
- FREQUENCY BAND: G.S.M.= 880~960 MHZ
1710~1880 MHZ
- GAIN: 0 dB
1880~2100 MHZ
- V.S.W.R.< 2.0

TOLERANCE m/m x. ±1.0 x.x ±0.50 x.xx ±0.15 x.xxx ±0.08 ANGULAR ±2° UNLESS OTHERWISE SPECIFIED	APPROVALS	DATE	TITLE GSM FLAT ANTENNA TRIPLE BAND, MMCX CONNECTOR 50 OHMS	 Amphenol Corporation Amphenol Taiwan Corporation
	DRAWN Ivy Hsu	11/17/04		
	CHECKED <input type="checkbox"/> Sondra Sang	11/17/04		
	APPROVED <input type="checkbox"/> Alex Chiu	11/17/04		
	UNIT MM	SIZE A4	PART NO. GAN 30071	SCALE N.A. SHEET 1 OF 1
			DRAWING NO. OTHER-GAN30071-29	REV. A