

SN54BCT646, SN74BCT646
OCTAL BUS TRANSCEIVERS AND REGISTERS
WITH 3-STATE OUTPUTS

SCBS037C – AUGUST 1989 – REVISED NOVEMBER 1993

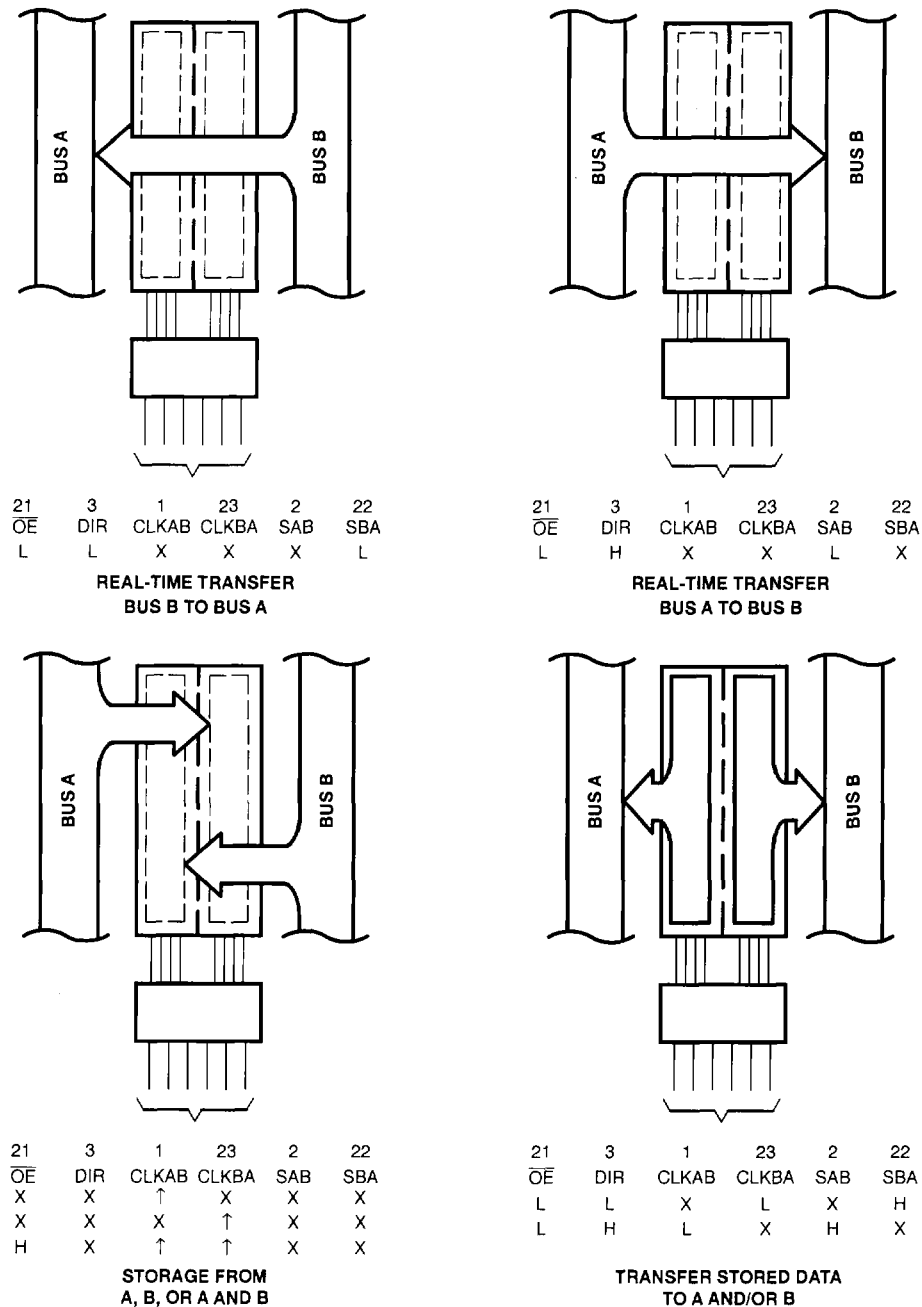

Figure 1. Bus-Management Functions

Pin numbers shown are for the DW, JT, NT, and W packages.



POST OFFICE BOX 655303 • DALLAS, TEXAS 75265

SN54BCT646, SN74BCT646 OCTAL BUS TRANSCEIVERS AND REGISTERS WITH 3-STATE OUTPUTS

SCBS037C – AUGUST 1989 – REVISED NOVEMBER 1993

FUNCTION TABLE

INPUTS						DATA I/O		OPERATION OR FUNCTION
OE	DIR	CLKAB	CLKBA	SAB	SBA	A1 THRU A8	B1 THRU B8	
X	X	↑	X	X	X	Input	Unspecified†	Store A, B unspecified†
X	X	X	↑	X	X	Unspecified†	Input	Store B, A unspecified†
H	X	↑	↑	X	X	Input	Input	Store A and B data
H	X	H or L	H or L	X	X	Input disabled	Input disabled	Isolation, hold storage
L	L	X	X	X	L	Output	Input	Real-time B data to A bus
L	L	X	H or L	X	H	Output	Input	Stored B data to A bus
L	H	X	X	L	X	Input	Output	Real-time A data to B bus
L	H	H or L	X	H	X	Input	Output	Stored A data to B bus

† The data output functions may be enabled or disabled by various signals at the OE and DIR inputs. Data input functions are always enabled; i.e., data at the bus pins will be stored on every low-to-high transition of the clock inputs.

logic symbol‡

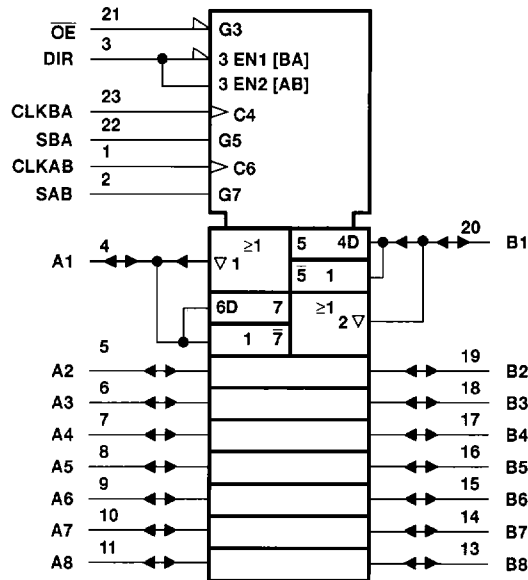

‡ This symbol is in accordance with ANSI/IEEE Std 91-1984 and IEC Publication 617-12. Pin numbers shown are for the DW, JT, NT, and W packages.

SN54BCT646, SN74BCT646
OCTAL BUS TRANSCEIVERS AND REGISTERS
WITH 3-STATE OUTPUTS

SCBS037C - AUGUST 1989 - REVISED NOVEMBER 1993

logic diagram (positive logic)

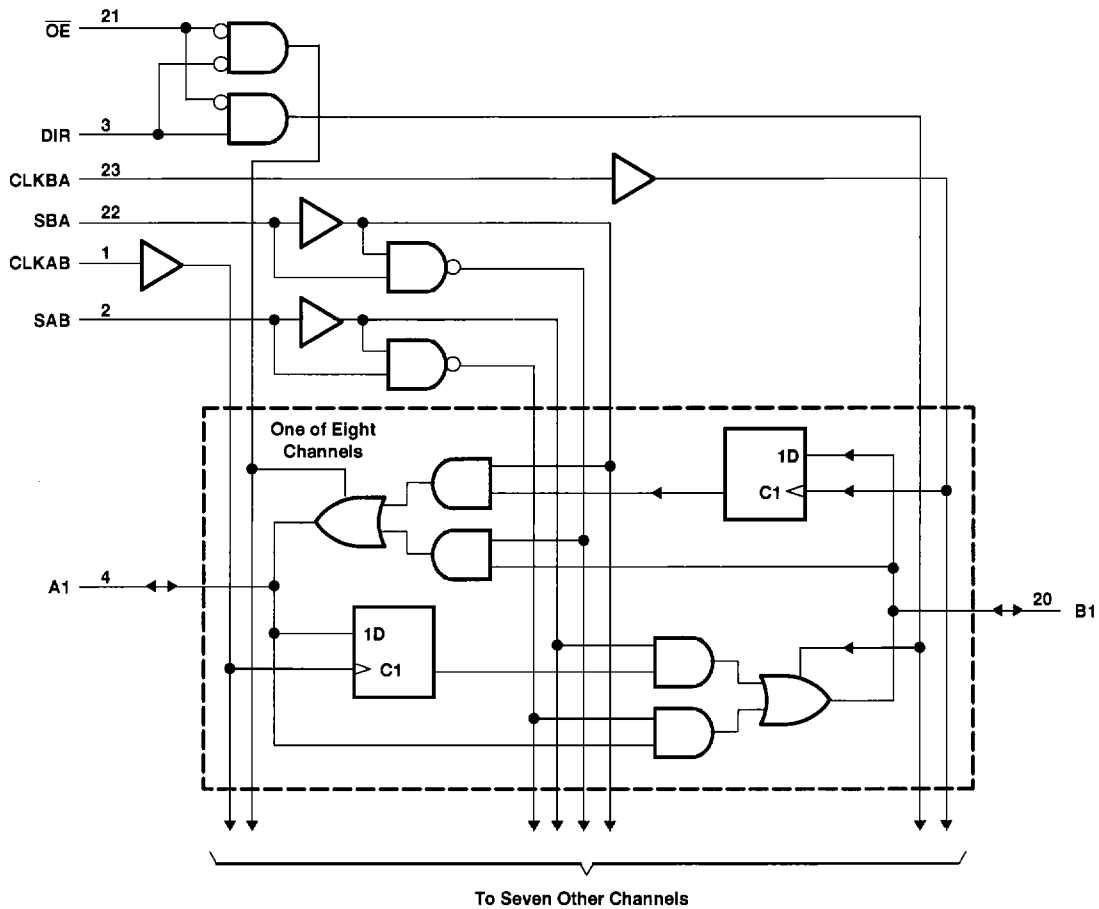

Pin numbers shown are for the DW, JT, NT, and W packages.



POST OFFICE BOX 655303 • DALLAS, TEXAS 75265

SN54BCT646, SN74BCT646
OCTAL BUS TRANSCEIVERS AND REGISTERS
WITH 3-STATE OUTPUTS

SCBS037C – AUGUST 1989 – REVISED NOVEMBER 1993

absolute maximum ratings over operating free-air temperature range (unless otherwise noted)†

Supply voltage range, V_{CC}	– 0.5 V to 7 V
Input voltage range: Control inputs (see Note 1)	– 0.5 V to 7 V
I/O ports (see Note 1)	– 0.5 V to 5.5 V
Voltage range applied to any output in the disabled or power-off state, V_O	– 0.5 V to 7 V
Voltage range applied to any output in the high state, V_O	– 0.5 V to V_{CC}
Current into any output in the low state: SN54BCT646	96 mA
SN74BCT646	128 mA
Operating free-air temperature range: SN54BCT646	– 55°C to 125°C
SN74BCT646	0°C to 70°C
Storage temperature range	– 65°C to 150°C

† Stresses beyond those listed under “absolute maximum ratings” may cause permanent damage to the device. These are stress ratings only, and functional operation of the device at these or any other conditions beyond those indicated under “recommended operating conditions” is not implied. Exposure to absolute-maximum-rated conditions for extended periods may affect device reliability.

NOTE 1: The input and output voltage ratings may be exceeded if the input and output current ratings are observed.

recommended operating conditions

		SN54BCT646			SN74BCT646			UNIT
		MIN	NOM	MAX	MIN	NOM	MAX	
V_{CC}	Supply voltage	4.5	5	5.5	4.5	5	5.5	V
V_{IH}	High-level input voltage	2			2			V
V_{IL}	Low-level input voltage			0.8			0.8	V
I_{IK}	Input clamp current			–18			–18	mA
I_{OH}	High-level output current			–12			–15	mA
I_{OL}	Low-level output current			48			64	mA
T_A	Operating free-air temperature	–55		125	0		70	°C



POST OFFICE BOX 655303 • DALLAS, TEXAS 75265

SN54BCT646, SN74BCT646
OCTAL BUS TRANSCEIVERS AND REGISTERS
WITH 3-STATE OUTPUTS

SCBS037C – AUGUST 1989 – REVISED NOVEMBER 1993

electrical characteristics over recommended operating free-air temperature range (unless otherwise noted)

PARAMETER	TEST CONDITIONS	SN54BCT646		SN74BCT646		UNIT		
		MIN	TYP†	MAX	MIN		TYP†	MAX
V_{IK}	$V_{CC} = 4.5\text{ V}$, $I_I = -18\text{ mA}$			-1.2		-1.2	V	
V_{OH}	$V_{CC} = 4.5\text{ V}$	$I_{OH} = -3\text{ mA}$	2.4	3.3	2.4	3.3	V	
		$I_{OH} = -12\text{ mA}$	2	3.2				
		$I_{OH} = -15\text{ mA}$			2	3.1		
V_{OL}	$V_{CC} = 4.5\text{ V}$	$I_{OL} = 48\text{ mA}$	0.38	0.55			V	
		$I_{OL} = 64\text{ mA}$			0.42	0.55		
I_I	A or B port	$V_{CC} = 5.5\text{ V}$, $V_I = 5.5\text{ V}$			1	1	mA	
	Control inputs				1	1		
$I_{IH}‡$	A or B port	$V_{CC} = 5.5\text{ V}$, $V_I = 2.7\text{ V}$			70	70	μA	
	Control inputs				20	20		
$I_{IL}‡$	A or B port	$V_{CC} = 5.5\text{ V}$, $V_I = 0.5\text{ V}$			-0.7	-0.7	mA	
	Control inputs				-0.7	-0.7		
$I_{OS}§$	$V_{CC} = 5.5\text{ V}$, $V_O = 0$			-100	-225	-100	-225	mA
I_{CCL}	A or B port $V_{CC} = 5.5\text{ V}$, $V_I = \text{GND}$			42	67	42	67	mA
I_{CCH}	A or B port $V_{CC} = 5.5\text{ V}$, $V_I = 4.5\text{ V}$			5.6	9	5.6	9	mA
I_{CCZ}	A or B port $V_{CC} = 5.5\text{ V}$, $V_I = \text{GND}$			10	16	10	16	mA
C_i	Control inputs $V_{CC} = 5\text{ V}$, $V_I = 2.5\text{ V or }0.5\text{ V}$			6		6		pF
C_{io}	A or B port $V_{CC} = 5\text{ V}$, $V_O = 2.5\text{ V or }0.5\text{ V}$			12		14		pF

† All typical values are at $V_{CC} = 5\text{ V}$, $T_A = 25^\circ\text{C}$.

‡ For I/O ports, the parameters I_{IH} and I_{IL} include the off-state output current.

§ Not more than one output should be tested at a time, and the duration of the test should not exceed one second.

timing requirements over recommended ranges of supply voltage and operating free-air temperature (unless otherwise noted)

		$V_{CC} = 5\text{ V}$, $T_A = 25^\circ\text{C}$		SN54BCT646		SN74BCT646		UNIT
		MIN	MAX	MIN	MAX	MIN	MAX	
f_{clock}	Clock frequency	0	83	0	83	0	83	MHz
t_w	Pulse duration, CLK high or low	6		6		6		ns
t_{su}	Setup time, A or B before CLKAB† or CLKBA†	6		7		6		ns
t_h	Hold time, A or B after CLKAB† or CLKBA†	0.5		0.5		0.5		ns



SN54BCT646, SN74BCT646
OCTAL BUS TRANSCEIVERS AND REGISTERS
WITH 3-STATE OUTPUTS

SCBS037C – AUGUST 1989 – REVISED NOVEMBER 1993

switching characteristics over recommended ranges of supply voltage and operating free-air temperature, $C_L = 50$ pF (unless otherwise noted) (see Note 2)

PARAMETER	FROM (INPUT)	TO (OUTPUT)	$V_{CC} = 5$ V, $T_A = 25^\circ$ C			SN54BCT646		SN74BCT646		UNIT
			MIN	TYP	MAX	MIN	MAX	MIN	MAX	
f_{max}			83			83		83		MHz
t_{PLH}	CLKBA or CLKAB	A or B	3.6	7	9.4	3.6	12.4	3.6	11.2	ns
t_{PHL}			3.9	7	9.2	3.9	11.5	3.9	10.6	
t_{PLH}	A or B	B or A	3.1	6	8.1	3.1	11.1	3.1	9.5	ns
t_{PHL}			3.7	6.8	8.9	3.7	12.1	3.7	10.5	
t_{PLH}	SAB or SBA† (with A or B high)	A or B	4.5	8.8	11.2	4.5	15.2	4.5	13.8	ns
t_{PHL}			3.3	6	8.1	3.3	9.8	3.3	9.1	
t_{PLH}	SAB or SBA† (with A or B low)	A or B	3.9	7.7	10.2	3.9	13.3	3.9	12	ns
t_{PHL}			4.7	8.3	10.8	4.7	13.7	4.7	12.9	
t_{PZH}	\overline{OE}	A or B	4	7.9	10.7	4	14	4	13.2	ns
t_{PZL}			4.6	8.8	11.8	4.6	15.4	4.6	14.4	
t_{PHZ}	\overline{OE}	A or B	4	7.2	9.4	4	12	4	10.9	ns
t_{PLZ}			3.4	7	9.3	3.4	11.6	3.4	10.5	
t_{PZH}	DIR	A or B	2.8	7.8	10.7	2.8	14	2.8	13.1	ns
t_{PZL}			3.8	8.9	11.9	3.8	15.6	3.8	14.6	
t_{PHZ}	DIR	A or B	3.8	8.4	10.7	3.8	13.2	3.8	12.6	ns
t_{PLZ}			3.2	7.3	9.9	3.2	12.6	3.2	11.8	

† These parameters are measured with the internal output state of the storage register opposite to that of the bus input.

NOTE 2: Load circuits and voltage waveforms are shown in Section 1.

