

PL-SxR-00-S43-Cx

850nm 10G ROSA

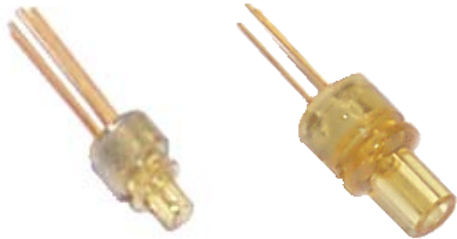

The Picolight 850nm PL-SxR-00-S43-Cx connectorized ROSA product (Receiver Optical Sub-Assembly) is designed for high-speed data communication applications. The product utilizes a GaAs PIN/TIA integrated in a custom hermetic TO package. Each device is actively aligned to a precision OSA housing using a proprietary alignment algorithm and tested to precise requirements. A controlled impedance flex circuit provides the user with optimum performance.

Features

- Data Rates up to 10 Gbps
- 3.3V Operation
- -40°C to 85°C Operation
- Differential Output
- Isolated Case
- Received Signal Strength Indicator (RSSI)
- LC or SC Connectorized PIN Plus Preamplifier

The PL-SxR-00-S43-Cx converts optical power into an electrical signal at data rates up to 10 Gbps and is engineered for performance over extended operating temperature and power conditions with high reliability.

Each part is electro-optically tested to insure optimum performance and sensitivity.

Benefits

- Optional Controlled Impedance Flex from OSA to PCBA for Excellent 10 Gbps Product Performance
- Industrial Operational Temperature
- Industry Standard Form Factor and Size
- Modulation Performance Verification

Ordering information

Part Number:	Description:	Contact Information
PL-SSR-00-S43-C1	850nm 10G ROSA w/SC Housing, RSSI Option 1	Picolight Incorporated 1480 Arthur Ave. Louisville, CO 80027 Tel: 303.530.3189 Web site: www.picolight.com
PL-SLR-00-S43-C1	850nm 10G ROSA w/LC Housing, RSSI Option 1	
PL-FSR-00-S43-C3	850nm 10G ROSA w/SC Housing, Flex Circuit, and RSSI Option 1	
PL-FLR-00-S43-C3	850nm 10G ROSA w/LC Housing, Flex Circuit, and RSSI Option 1	
PL-FSR-00-S43-C4	850nm 10G ROSA w/SC Housing, Flex Circuit, and RSSI Option 2	
PL-FLR-00-S43-C4	850nm 10G ROSA w/LC Housing, Flex Circuit, and RSSI Option 2	

Absolute maximum ratings

(T_{case} = 30°C, Continuous Wave (CW) operation unless otherwise stated)

Parameter	Symbol	Ratings	Unit	Notes
Storage Temperature	T _{st}	-40 to +100	°C	
Incident Optical Power	P _{in}	+5	dBm	
Lead Solder Temperature	T _s	260°C for 10 sec. 2mm from case		
Flex Attach Temperature	T _F	370°C for 10 sec.		
Power Supply Voltage	V _p	4.0	V	

Notice

Conditions exceeding those listed may cause permanent damage to the device. Devices subjected to conditions beyond the limits specified for extended periods of time may adversely affect reliability.

Electro-optical characteristics

(T_{case} = 30°C, V_{cc} = 3.3V unless otherwise stated)

Parameter	Symbol	Min.	Typ.	Max.	Unit	Notes
Wavelength Responsivity	λ	840	850	860	nm	
Case Operating Temperature	T _{op}	-40		85	°C	
Supply Voltage	V _{cc}	2.97	3.3	3.63	V	
Supply Current	I _{cc}	43	55	73	mA	
Bandwidth	BW	8.0			GHz	
Low Freq Cutoff			30	52	KHz	
Responsivity (@50 MHz)	R	1200		3000	V/W	
Sensitivity (OMA)	S		-13	-12	dBm	
Output Resistance	R _o		100		Ω	
Optical Overload		1.5			dBm	
Differential Output Voltage	V _{out}	150		330	mV	
Duty Cycle Distortion			1	10	%	
Rise/Fall Time	T _R /T _F	20		45	ps	
Slope of RSSI vs P _{in}	RSSI slope		1			
RSSI Current with Zero Input	RSSI offset			100	uA	RSSI Option1
				0		RSSI Option2
RSSI Linearity Range	RSSI range	5		1100	uA	

ROSA Without Flex Dimensions (SC)

UNITS: MM

.X = ±0.2
.XX = ±0.10
.XXX = ±0.050

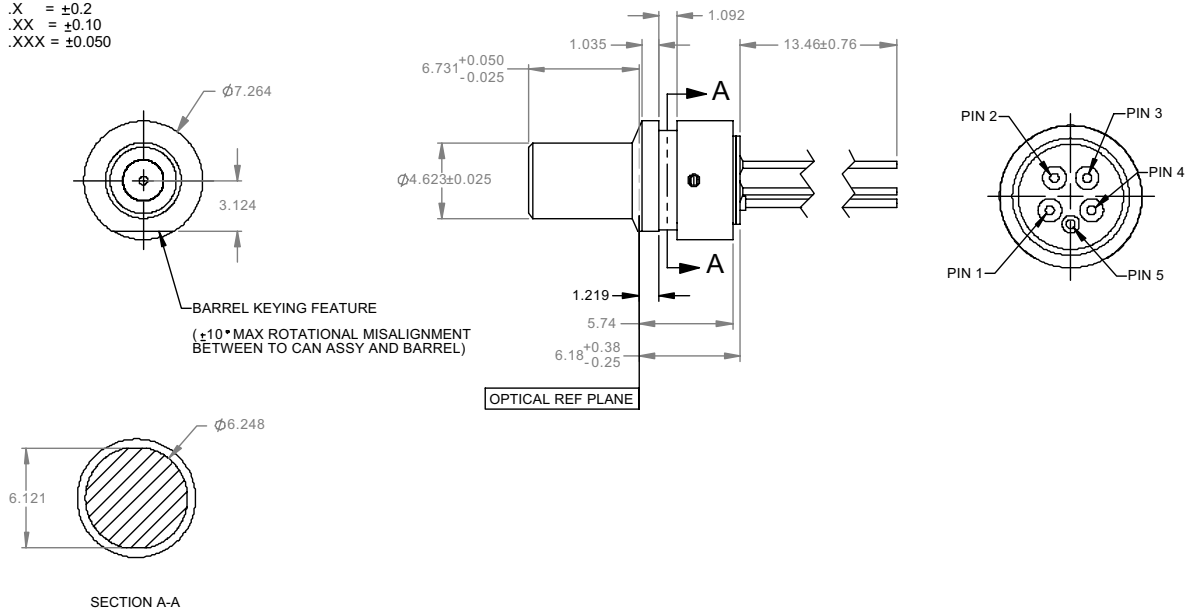

ROSA Without Flex Dimensions (LC)

UNITS: MM

.X = ±0.2
.XX = ±0.10
.XXX = ±0.050

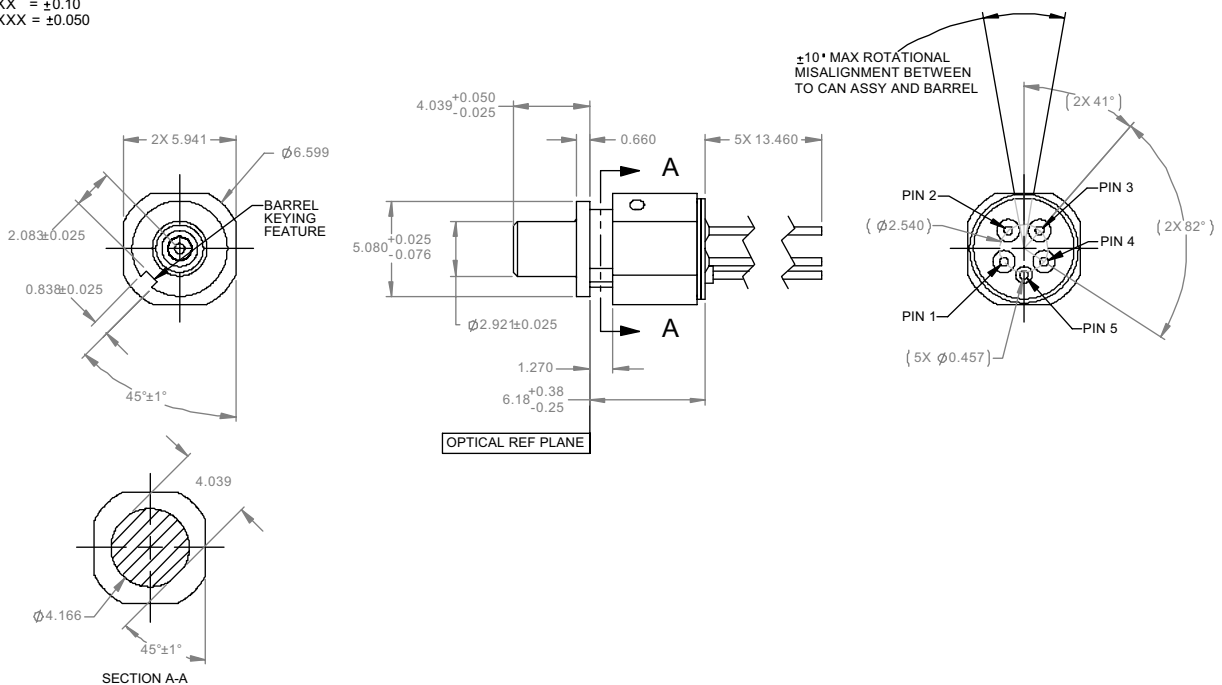

ROSA with Flex Dimensions (SC)

UNITS: MM

.X = ±0.2
.XX = ±0.10
.XXX = ±0.050

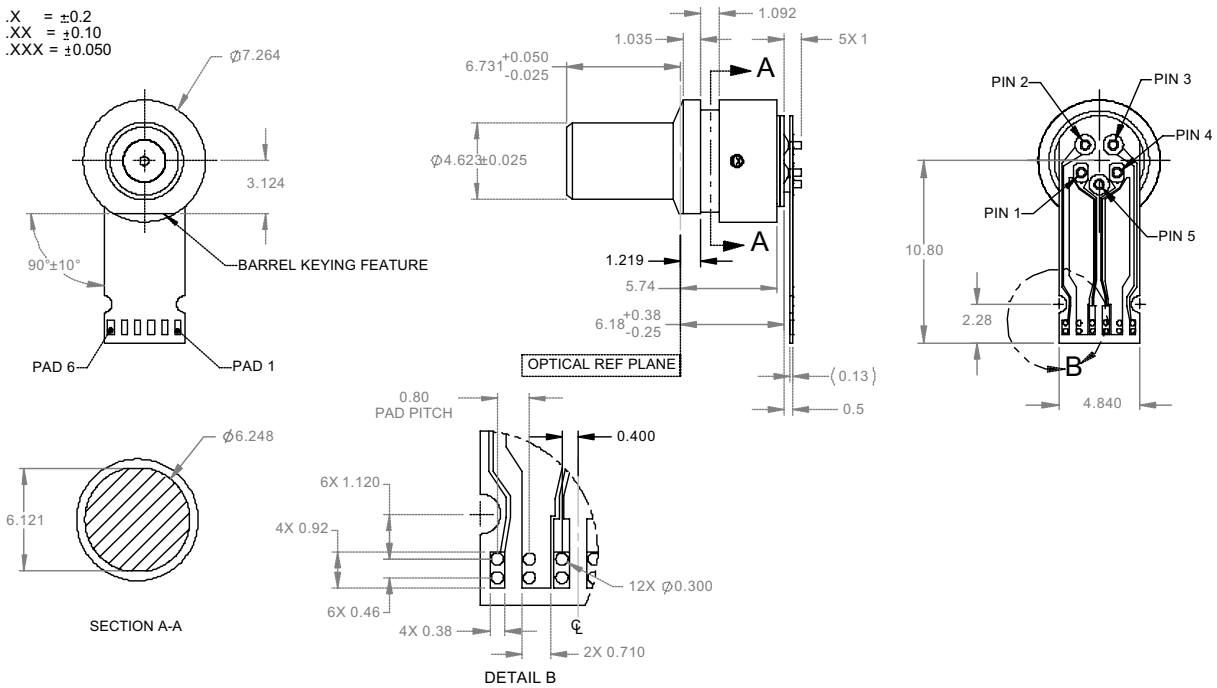

ROSA with Flex Dimensions (LC)

UNITS: MM

.X = ±0.2
.XX = ±0.10
.XXX = ±0.050

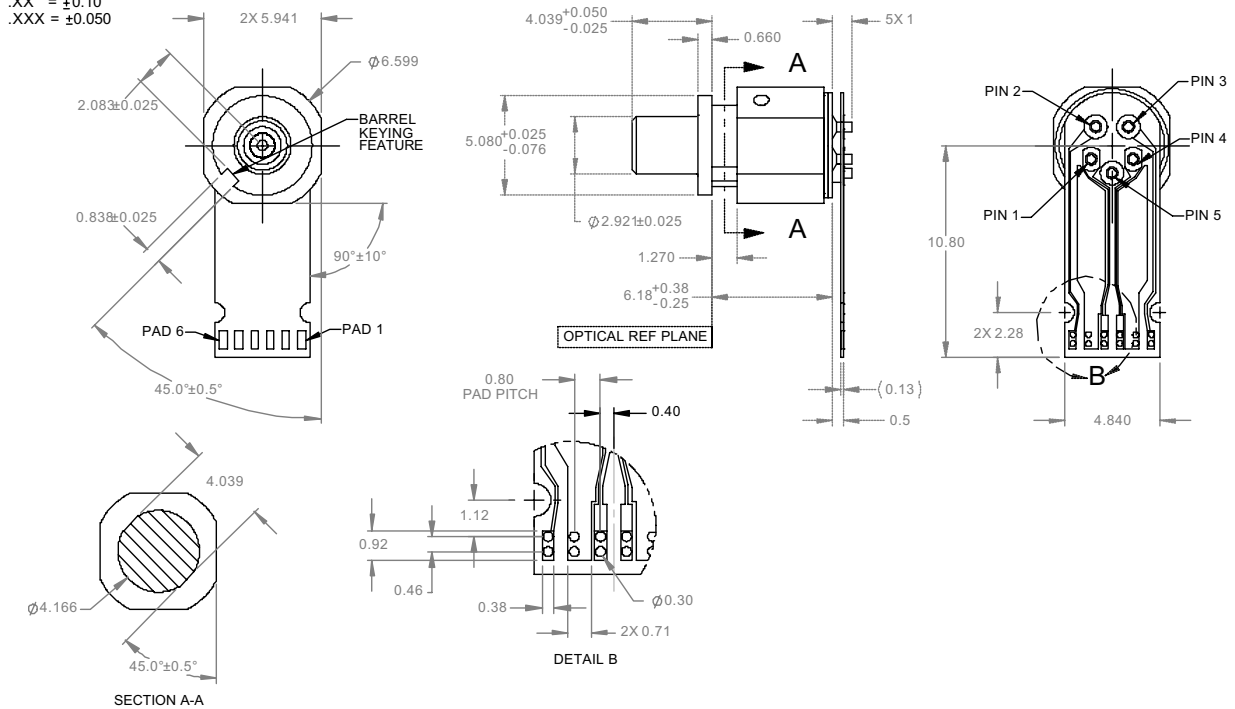

Pinout Options

PL-SxR-00-S43-C1 (no flex)		
Pin	Symbol	Function
1	Vout P	TIA Output Voltage (Non-Inverted)
2	Vdd	Positive Supply Voltage
3*	RSSI	Receive Signal Power, Avg. Current
4	Vout N	TIA Output Voltage (Inverted)
5	GND	Ground

PL-FxR-00-S43-C3 and PL-FxR-00-S43-C4 (with flex)		
Pad	Symbol	Function
1	Vcc	Vcc
2	GND	Ground
3	Vout P	TIA Output Voltage (Non-Inverted)
4	Vout N	TIA Output Voltage (Inverted)
5	GND	Ground
6*	RSSI	Receive Signal Power, Avg. Current

*RSSI Pin Connection Options

Option	Part Number	RSSI Connection
1	PL-SxR-00-S43-C1 PL-FxR-00-S43-C3	Connect RSSI to ground with a resistor <2500 ohms
2	PL-FxR-00-S43-C4	Connect RSSI to Vcc with a resistor <2500 ohms

Shipping information

Shipped in anti-static stackable trays.