

4-Channel 933 Mbit/s to 1.25 Gbit/s Transceiver

FEATURES

GENERAL

- Four independent 933 Mbit/s to 1.25 Gbit/s IEEE 802.3-2000 Gigabit Ethernet and Fibre Channel Physical Interfaces (FC-PI) System Compliant Transceivers.
- Integrated clock synthesis, clock recovery, serializer/deserializer, built-in self-test, 8B/10B codec.
- IEEE 802.3-2000 Gigabit Ethernet Physical Coding Sublayer (PCS) logic.
- Rate matching via IDLE character insertion and deletion capable of compensating up to ± 200 ppm of clock difference between channels.
- Pin programmable or software configurable operation using 2-pin IEEE 802.3 MDC/MDIO serial management interface.
- Supports pin-programmable hardware-only device configuration.

- Minimal external components required.
- 1.5 V and 1.8 V RGMII/RTBI interface.
- 1.8 V and 2.5 V LVCMOS interoperable for all other digital I/O.

SERIAL INTERFACE

- High-speed outputs feature programmable output current to optimize drive distance and power - directly drives 50 Ω (100 Ω differential) systems.
- Integrated 100 Ω differential resistive termination for a smaller solution footprint, easier layout and improved signal integrity.
- Direct AC coupled interface to copper serial backplanes, optics and coaxial cable.

PARALLEL INTERFACE

- 5-bit Dual Data Rate Interface compliant with RGMII/RTBI v2.0 standard.
- Receive channel output clocks eliminate the need for PLLs in interface ASICs.
- 1.5 V and 1.8 V HSTL interoperable on RGMII/RTBI digital I/O.

TEST FEATURES

- IEEE 1149.1 JTAG Boundary Scan support.
- Built-in self-test (BIST) via internal packet generator/checker.
- Per-channel control of serial and parallel loopbacks.
- 8B/10B error counters.

BLOCK DIAGRAM

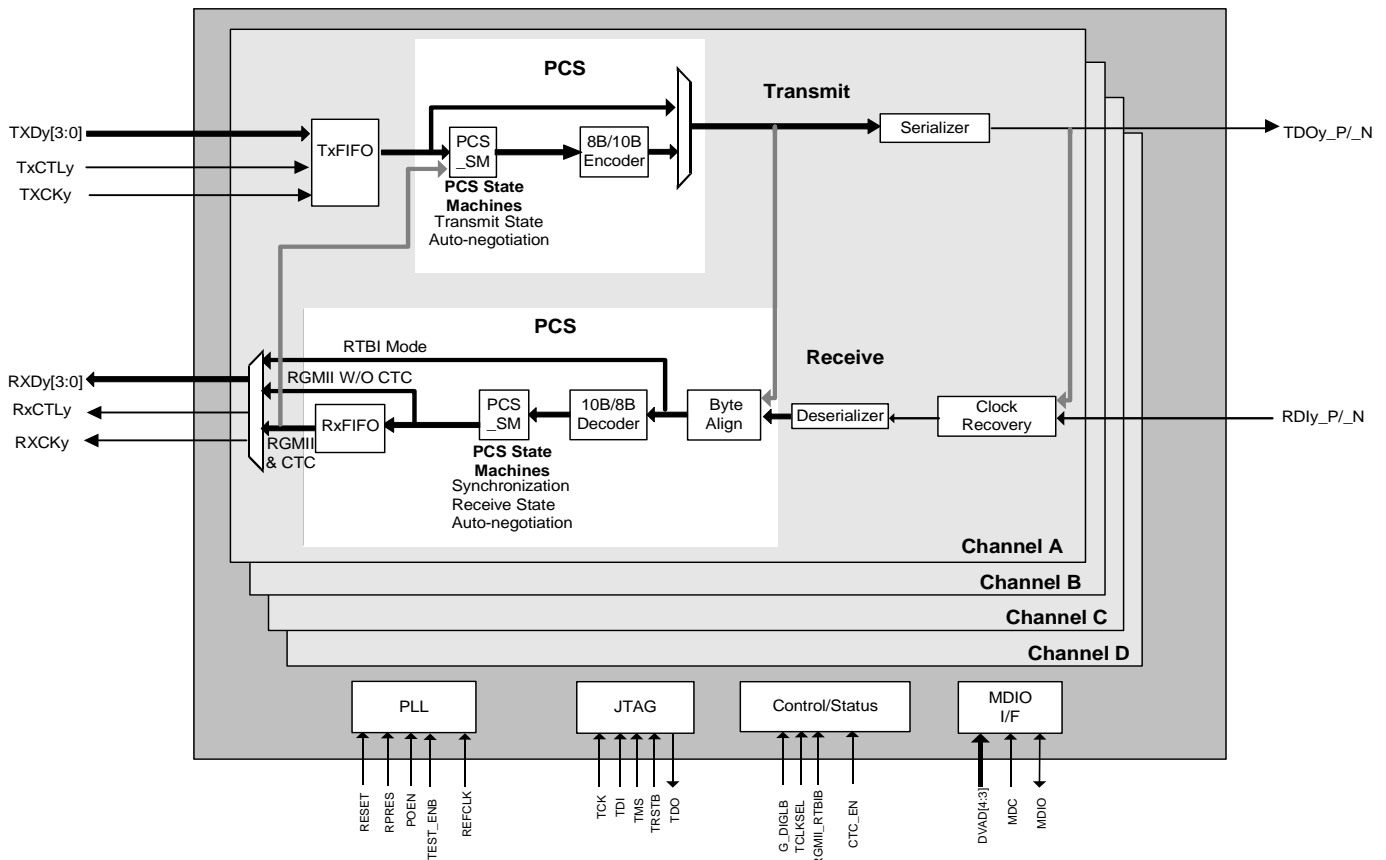

4-Channel 933 Mbit/s to 1.25 Gbit/s Transceiver

PHYSICAL

- Ultra-low power operation using 0.18 μ CMOS technology.
- 196-pin, 15 mm x 15 mm BGA package.
- 1.8 V core and analog power.
- 1.5 V and 1.8 V interoperable HSTL signals.
- 1.8 V and 2.5 V interoperable LVCMOS Signals.
- Designed to operate over a wide temperature range (-40 to +85 °C) and is suited for central office and outside plant equipment.

APPLICATIONS

- High-speed serial backplanes.
- IEEE 802.3-2000 Gigabit Ethernet dense line cards.
- ANSI X3T11 Fibre Channel dense line cards.
- Link Aggregation.
- Intra-system and inter-system interconnect.
- Chassis Extender.

TYPICAL APPLICATIONS

GIGABIT ETHERNET & FIBRE CHANNEL SWITCH APPLICATION

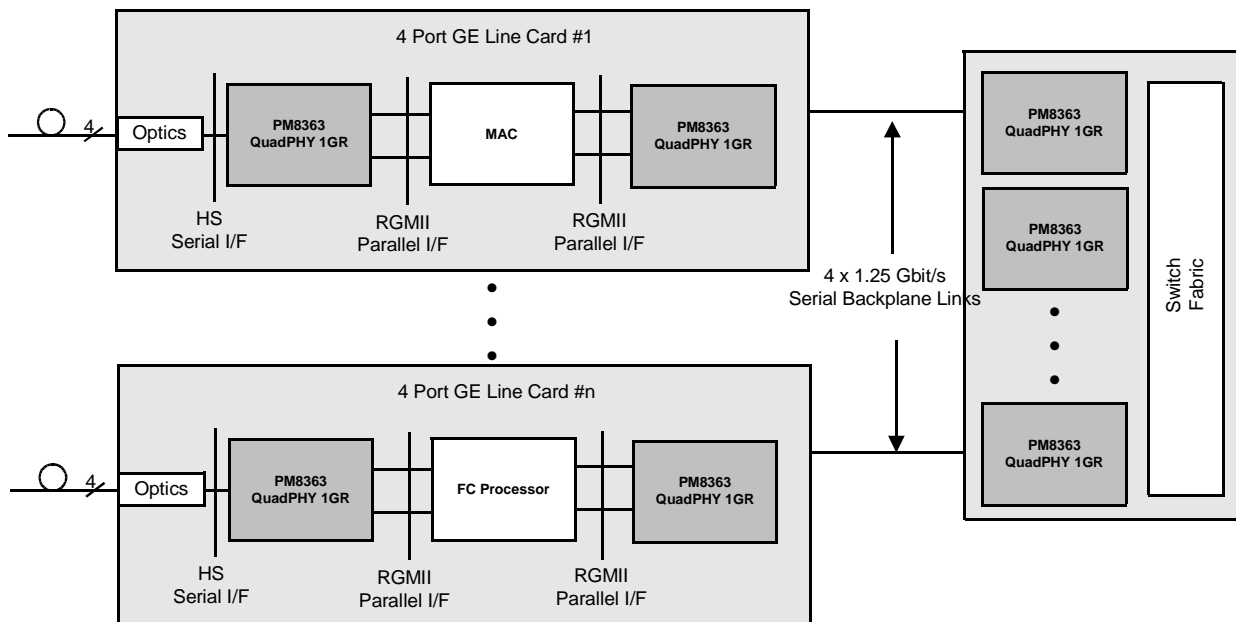

Head Office:
 PMC-Sierra, Inc.
 8555 Baxter Place
 Burnaby, B.C. V5A 4V7
 Canada
 Tel: 1.604.415.6000
 Fax: 1.604.415.6200

To order documentation,
 send email to:
 document@pmc-sierra.com
 or contact the head office,
 Attn: Document Coordinator

All product documentation is available
 on our web site at:
<http://www.pmc-sierra.com>
 For corporate information,
 send email to:
 info@pmc-sierra.com

PMC-2030883 (r2)
 PMC, PMCS, and PMC-Sierra are
 trademarks of PMC-Sierra, Inc.
 Other product and company names
 mentioned herein may be the trademarks of
 their respective owners.