

TOSHIBA FIELD EFFECT TRANSISTOR
GaAs N CHANNEL SINGLE GATE MODULATION DOPE TYPE

2SK2331

SHF BAND LOW NOISE AMPLIFIER APPLICATIONS

Unit in mm

- Low Noise Figure : $NF=0.45\text{dB}$ ($f=12\text{GHz}$)
- High Gain : $G_a=11\text{dB}$ ($f=12\text{GHz}$)

MAXIMUM RATINGS ($T_a = 25^\circ\text{C}$)

CHARACTERISTIC	SYMBOL	RATING	UNIT
Gate-Drain Voltage	V_{GDO}	-3	V
Gate-Source Voltage	V_{GSO}	-3	V
Drain Current	I_D	120	mA
Power Dissipation	P_D	150	mW
Channel Temperature	T_{ch}	125	$^\circ\text{C}$
Storage Temperature Range	T_{stg}	-55~125	$^\circ\text{C}$

Marking

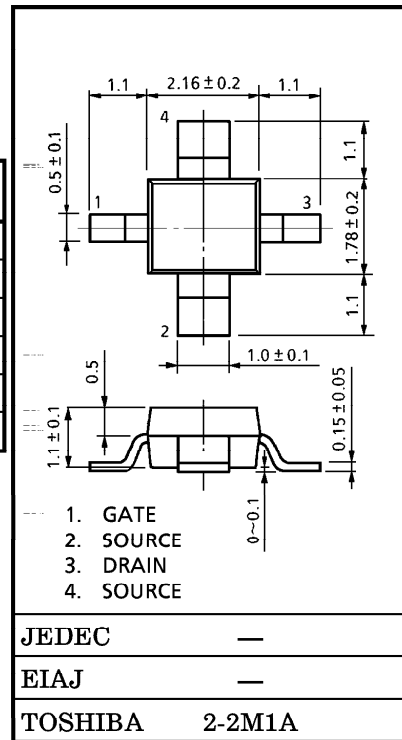
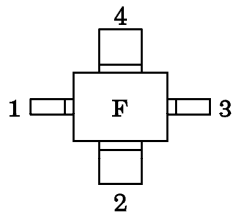

JEDEC	—
EIAJ	—
TOSHIBA	2-2M1A

Weight : 0.016g (Typ.)

ELECTRICAL CHARACTERISTICS ($T_a = 25^\circ\text{C}$)

CHARACTERISTIC	SYMBOL	TEST CONDITION	MIN.	TYP.	MAX.	UNIT
Gate Leakage Current	I_{GSS}	$V_{DS}=0, V_{GS}=-2\text{V}$	—	—	-20	μA
Drain Current	I_{DSS}	$V_{DS}=1\text{V}, V_{GS}=0$	25	70	120	mA
Gate-Source Cut-off Voltage	$V_{GS(OFF)}$	$V_{DS}=1\text{V}, I_D=100\mu\text{A}$	-0.2	-0.8	-2	V
Forward Transfer Admittance	$ Y_{fs} $	$V_{DS}=1\text{V}, I_D=20\text{mA}, f=1\text{kHz}$	—	100	—	mS
Noise Figure	NF	$V_{DS}=1\text{V}, I_D=20\text{mA}, f=12\text{GHz}$	—	0.45	0.6	dB
Associated Gain	G_a	$V_{DS}=1\text{V}, I_D=20\text{mA}, f=12\text{GHz}$	10	11	—	dB

CAUTION

GaAs (Gallium Arsenide) is used in this product. The dust or vapor can be dangerous to humans. Do not break, cut, crush or dissolve chemically. Dispose of this product properly according to law. Do not intermingle with normal industrial or domestic waste.

This device electrostatic sensitivity. Please handle with caution.

961001EAC2

- TOSHIBA is continually working to improve the quality and the reliability of its products. Nevertheless, semiconductor devices in general can malfunction or fail due to their inherent electrical sensitivity and vulnerability to physical stress. It is the responsibility of the buyer, when utilizing TOSHIBA products, to observe standards of safety, and to avoid situations in which a malfunction or failure of a TOSHIBA product could cause loss of human life, bodily injury or damage to property. In developing your designs, please ensure that TOSHIBA products are used within specified operating ranges as set forth in the most recent products specifications. Also, please keep in mind the precautions and conditions set forth in the TOSHIBA Semiconductor Reliability Handbook.
- Gallium arsenide (GaAs) is a substance used in the products described in this document. GaAs dust and fumes are toxic. Do not break, cut or pulverize the product, or use chemicals to dissolve them. When disposing of the products, follow the appropriate regulations. Do not dispose of the products with other industrial waste or with domestic garbage.
- The information contained herein is presented only as a guide for the applications of our products. No responsibility is assumed by TOSHIBA CORPORATION for any infringements of intellectual property or other rights of the third parties which may result from its use. No license is granted by implication or otherwise under any intellectual property or other rights of TOSHIBA CORPORATION or others.
- The information contained herein is subject to change without notice.

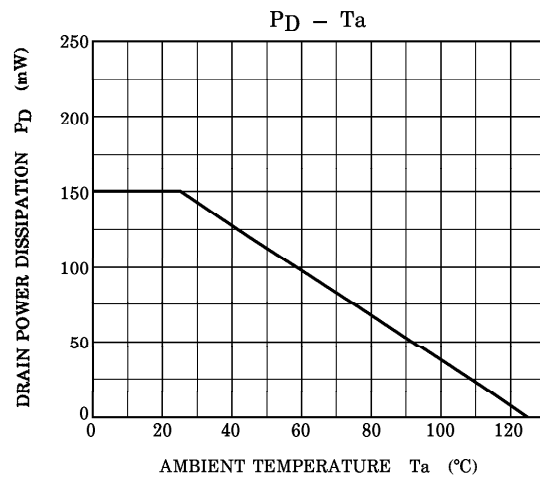
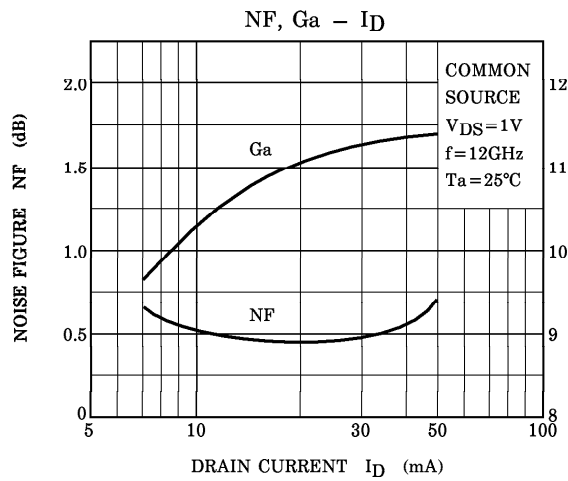
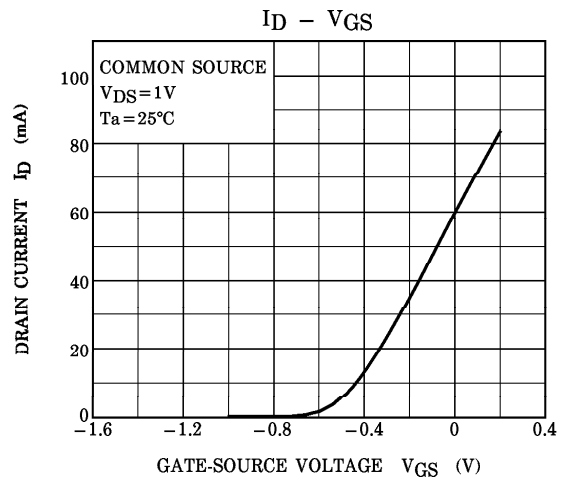
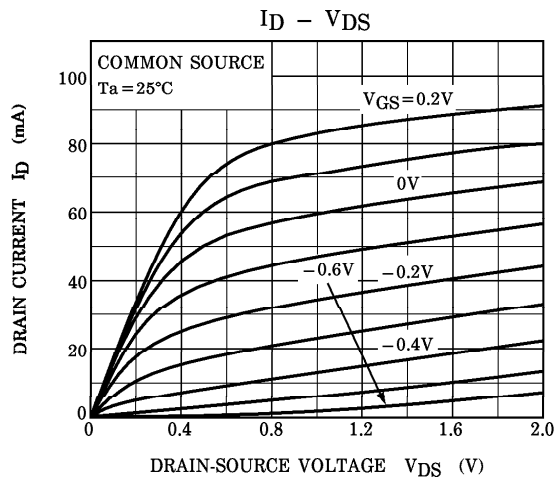

S-PARAMETER

COMMON SOURCE

($V_{DS}=1V$, $I_D=20mA$, $T_a=25^\circ C$, $Z_0=50\Omega$)

FREQ. (MHz)	S ₁₁		S ₂₁		S ₁₂		S ₂₂	
	MAG	ANG	MAG	ANG	MAG	ANG	MAG	ANG
2000	0.935	-32	5.581	148	0.037	77	0.143	-11
3000	0.871	-51	5.352	133	0.054	71	0.117	-26
4000	0.803	-70	5.050	117	0.070	61	0.084	-40
5000	0.734	-90	4.741	98	0.087	51	0.042	-81
6000	0.670	-110	4.377	84	0.098	43	0.047	-166
7000	0.622	-128	3.969	71	0.108	34	0.071	166
8000	0.570	-147	3.637	57	0.117	25	0.086	139
9000	0.525	-168	3.310	42	0.120	13	0.133	114
10000	0.518	172	3.062	29	0.128	5	0.177	104
11000	0.526	156	2.874	17	0.136	-4	0.206	95
12000	0.541	135	2.696	-1	0.143	-18	0.245	81
13000	0.564	115	2.523	-15	0.146	-29	0.287	69
14000	0.588	95	2.401	-32	0.150	-42	0.318	57
15000	0.637	71	2.200	-52	0.156	-59	0.384	41
16000	0.688	48	1.887	-70	0.146	-74	0.469	25

S₁₁
COMMON SOURCE
V_{DS}=1V
I_D=20mA
T_a=25°C
(UNIT : Ω)

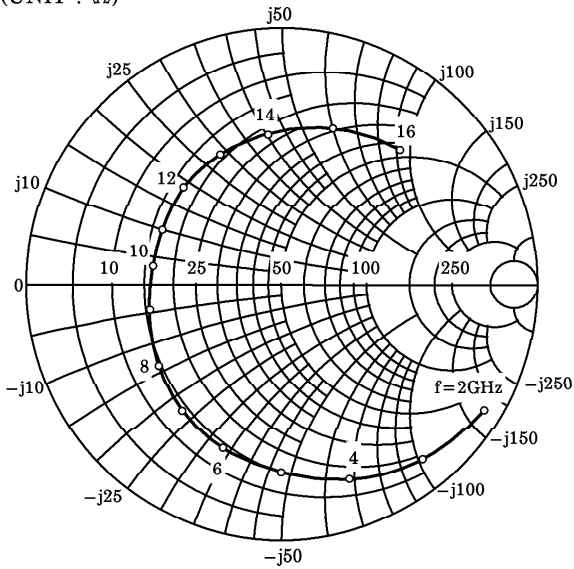

S₂₁
COMMON SOURCE
V_{DS}=1V
I_D=20mA
T_a=25°C

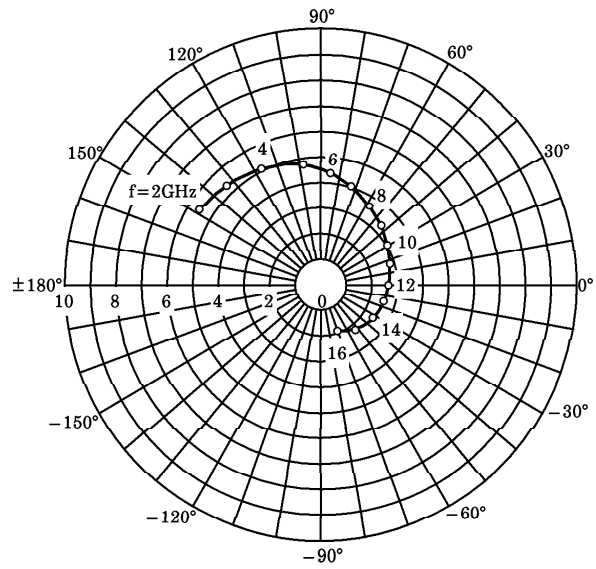

S₁₂
COMMON SOURCE
V_{DS}=1V
I_D=20mA
T_a=25°C

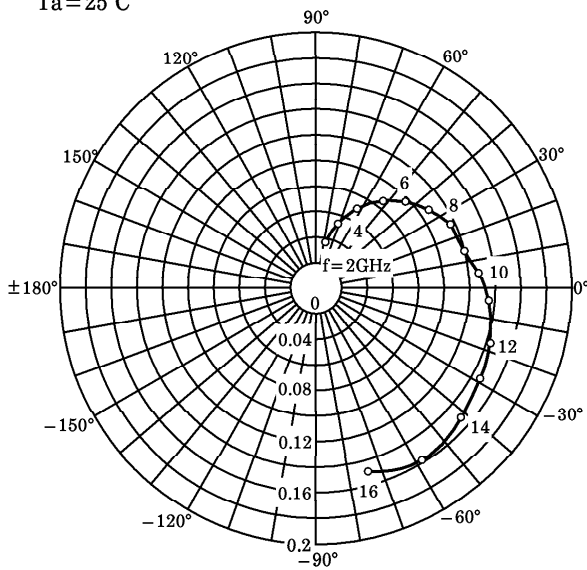

S₂₂
COMMON SOURCE
V_{DS}=1V
I_D=20mA
T_a=25°C
(UNIT : Ω)

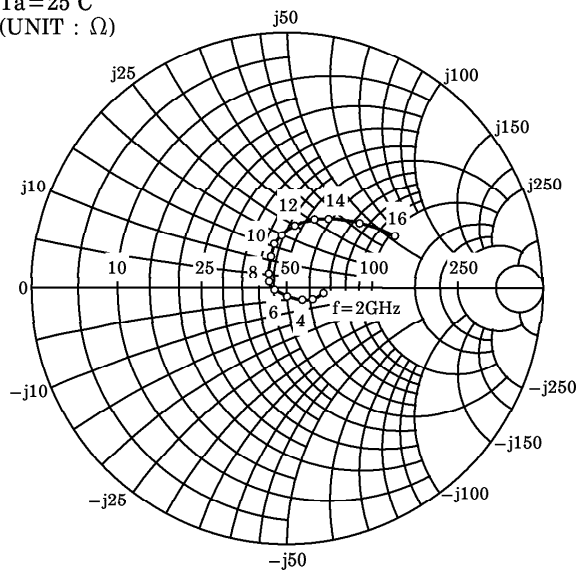

CONSTANT NOISE FIGURE

NF min = 0.45dB, $\Gamma_{opt} = 0.33 \angle -167$, $R_n = 1.7\Omega$

@ $V_{DS} = 1V$, $I_D = 20mA$, $f = 12GHz$

$Z_0 = 50\Omega$, $T_a = 25^\circ C$

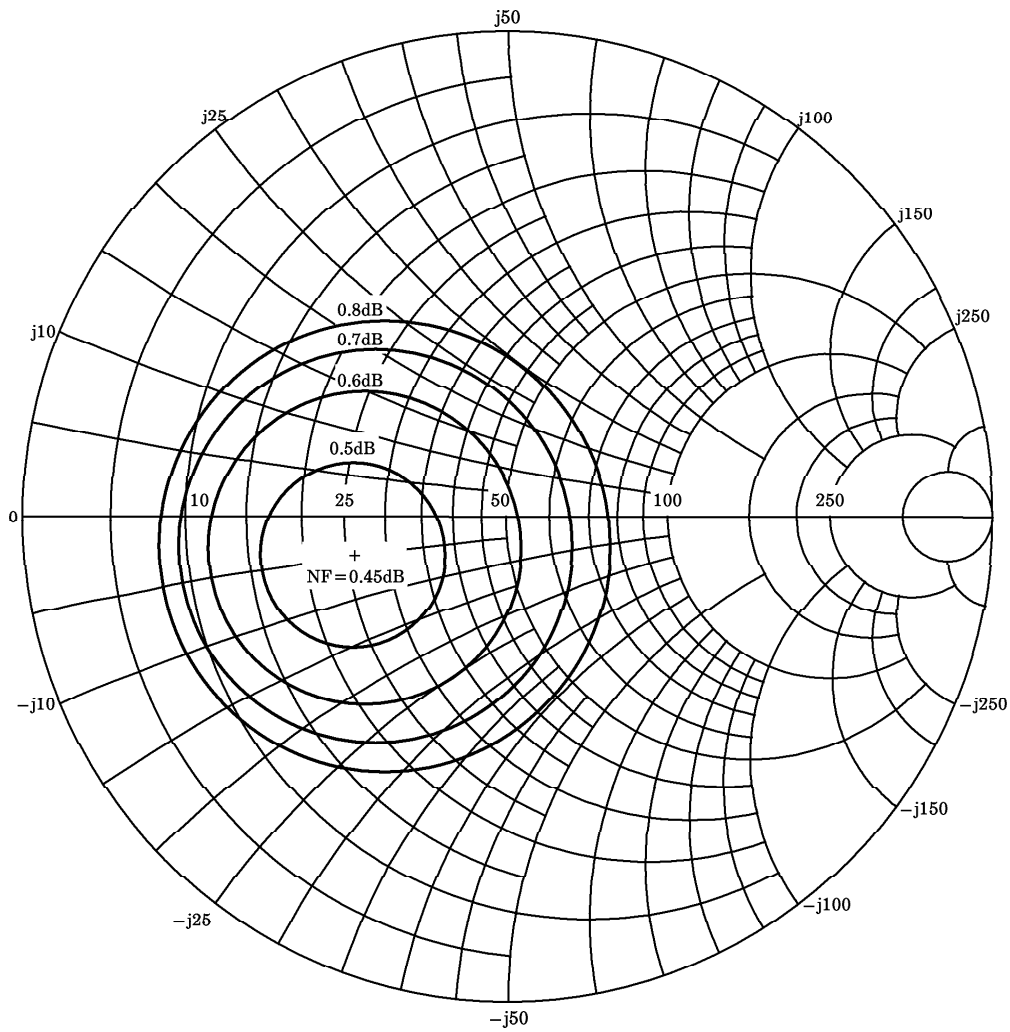

Recommended Methods of Mounting for This Device

Mounting method				
Solder flow	Nearinfrared reflow	Farinfrared reflow	VPS & hot air reflow	Soldering iron
×	○	◎	◎	○

◎ : Applicable

○ : Applicable only once

× : Not applicable; other methods are recommended.

Note 1 : For either method of mounting, the above table shows whether applicable or not under Toshiba's recommended mounting conditions.

Note 2 : When mounted a number of times, those marked by ◎ can only be used. In this case, mounting is allowed up to three times, with the interval from the first to the third mounting completed within 24 hours.