

**KS54HCTLS
KS74HCTLS 533**

**Octal D-Type Transparent Latches
with 3-State Outputs T-46-07-05**

FEATURES

- 8 latches in a single package
- Full parallel access for loading
- Function, pin-out, speed and drive compatibility with 54/74LS logic family
- Low power consumption characteristic of CMOS
- 3-State outputs with high drive current (I_{OL} = 24 mA @ V_{OL} = 0.5V) for direct bus interface
- Inputs and outputs interface directly with TTL, NMOS and CMOS devices
- Wide operating voltage range: 4.5V to 5.5V
- Characterized for operation over industrial and military temperature ranges:
KS74HCTLS: -40°C to +85°C
KS54HCTLS: -55°C to +125°C
- Package options include plastic "small outline" packages, standard plastic and ceramic 300-mil DIPs

DESCRIPTION

The '533 consists of 8 high-speed D-type latches coupled to 3-state output buffers with high drive current capability. It can be used in implementing buffer registers, I/O ports, bidirectional bus drivers and working registers.

The latches are transparent: when the enable (C) is high, the Q outputs follow the complements of the data (D) inputs. When the enable is low, the outputs latch at the levels that were set up at the D inputs.

The output buffers are controlled by a common signal (\overline{OC}) which places the outputs at high-impedance state when it is taken high. The \overline{OC} signal does not affect the internal operations of the latches. Old data can be retained or new data can be entered while outputs are off.

These devices provide speeds and drive capability equivalent to their LSTTL counterparts and yet maintain CMOS power levels. The input and output voltage levels allow direct interface with TTL, NMOS and CMOS devices without any external components.

All inputs and outputs are protected from damage due to static discharge by internal diode clamps to V_{cc} and ground.

PIN CONFIGURATION

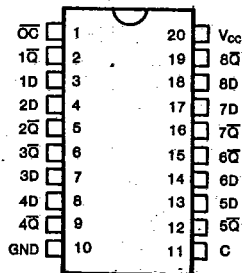

FUNCTION TABLE

(Each Latch)

Inputs			Output
\overline{OC}	Enable C	D	Q
L	H	H	L
L	H	L	H
L	L	X	Q ₀
H	X	X	Z

LOGIC DIAGRAM

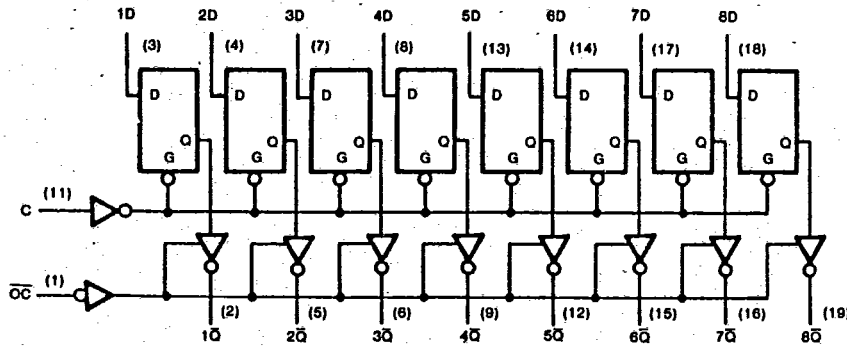

KS54HCTLS 533
KS74HCTLS

Octal D-Type Transparent Latches
with 3-State Outputs T-46-07-05

Absolute Maximum Ratings*

Supply Voltage Range V_{CC} , -0.5V to +7V
 DC Input Diode Current, I_{IK}
 ($V_I < -0.5V$ or $V_I > V_{CC} + 0.5V$) ± 20 mA
 DC Output Diode Current, I_{OK}
 ($V_O < -0.5V$ or $V_O > V_{CC} + 0.5V$) ± 20 mA
 Continuous Output Current Per Pin, I_O
 ($-0.5V < V_O < V_{CC} + 0.5V$) ± 70 mA
 Continuous Current Through
 V_{CC} or GND pins ± 250 mA
 Storage Temperature Range, T_{stg} -65°C to $+150^\circ\text{C}$
 Power Dissipation Per Package, P_{d1} 500 mW

* Absolute Maximum Ratings are those values beyond which permanent damage to the device may occur. These are stress ratings only and functional operation of the device at or beyond them is not implied. Long exposure to these conditions may affect device reliability.

† Power Dissipation temperature derating:
 Plastic Package (N): $-12\text{mW}/^\circ\text{C}$ from 65°C to 85°C
 Ceramic Package (J): $-12\text{mW}/^\circ\text{C}$ from 100°C to 125°C

Recommended Operating Conditions

Supply Voltage, V_{CC} 4.5V to 5.5V
 DC Input & Output Voltages*, V_{IN} , V_{OUT} ... 0V to V_{CC}
 Operating Temperature
 Range KS74HCTLS: -40°C to $+85^\circ\text{C}$
 KS54HCTLS: -55°C to $+125^\circ\text{C}$
 Input Rise & Fall Times, t_r , t_f * Max 500 ns
 * Unused inputs must always be tied to an appropriate logic voltage level (either V_{CC} or GND)

DC ELECTRICAL CHARACTERISTICS ($V_{CC}=5V \pm 10\%$ Unless Otherwise Specified)

Characteristic	Symbol	Test Conditions	$T_a = 25^\circ\text{C}$			Unit	
			Typ	KS74HCTLS $T_a = -40^\circ\text{C}$ to $+85^\circ\text{C}$	KS54HCTLS $T_a = -55^\circ\text{C}$ to $+125^\circ\text{C}$		Guaranteed Limits
Minimum High-Level Input Voltage	V_{IH}			2.0	2.0	2.0	V
Maximum Low-Level Input Voltage	V_{IL}			0.8	0.8	0.8	V
Minimum High-Level Output Voltage	V_{OH}	$V_{IN}=V_{IH}$ or V_{IL} $I_O = -20\mu\text{A}$ $I_O = -6\text{mA}$	V_{CC} 4.2	$V_{CC} - 0.1$ 3.98	$V_{CC} - 0.1$ 3.84	$V_{CC} - 0.1$ 3.7	V
Maximum Low-Level Output Voltage	V_{OL}	$V_{IN}=V_{IH}$ or V_{IL} $I_O = 20\mu\text{A}$ $I_O = 12\text{mA}$ $I_O = 24\text{mA}$	0	0.1 0.26 0.39	0.1 0.33 0.5	0.1 0.4	V
Maximum Input Current	I_{IN}	$V_{IN}=V_{CC}$ or GND		± 0.1	± 1.0	± 1.0	μA
Maximum 3-State Leakage Current	I_{OZ}	Output Enable = V_{IH} $V_{OUT}=V_{CC}$ or GND		± 0.5	± 5.0	± 10.0	μA
Maximum Quiescent Supply Current	I_{CC}	$V_{IN}=V_{CC}$ or GND $I_{OUT}=0\mu\text{A}$		8.0	80.0	160.0	μA
Additional Worst Case Supply Current	ΔI_{CC}	per input pin $V_I = 2.4V$ other inputs: at V_{CC} or GND $I_{OUT}=0\mu\text{A}$		2.7	2.9	3.0	mA

5

KS54HCTLS
KS74HCTLS **533****Octal D-Type Transparent Latches
with 3-State Outputs T-46-07-05****AC ELECTRICAL CHARACTERISTICS** (Input $t_r, t_f \leq 6$ ns; HCTLS533)

Characteristic	Symbol	Conditions†	$T_a = 25^\circ\text{C}$ $V_{CC} = 5.0\text{V}$		KS74HCTLS	KS54HCTLS	Unit	
			Typ	Guaranteed Limits				
					$T_a = -40^\circ\text{C to } +85^\circ\text{C}$ $V_{CC} = 5.0\text{V} \pm 10\%$	$T_a = -55^\circ\text{C to } +125^\circ\text{C}$ $V_{CC} = 5.0\text{V} \pm 10\%$		
Maximum Propagation Delay, D to Q	t_{PLH}	$C_L = 50\text{pF}$ $C_L = 150\text{pF}$	14 17	18 21	23 28	27 33	ns	
	t_{PHL}	$C_L = 50\text{pF}$ $C_L = 150\text{pF}$	14 17	18 21	23 28	27 33		
Maximum Propagation Delay C to Q	t_{PLH}	$C = 50\text{pF}$ $C_L = 150\text{pF}$	22 25	30 33	37 43	45 41	ns	
	t_{PHL}	$C_L = 50\text{pF}$ $C_L = 150\text{pF}$	22 25	30 33	37 43	48 54		
Maximum Output Enable Time, \overline{OC} to any Q	t_{PZH}	$R_L = 1\text{k}\Omega$	$C_L = 50\text{pF}$ $C_L = 150\text{pF}$	24 27	32 35	40 45	48 54	ns
	t_{PZL}		$C_L = 50\text{pF}$ $C_L = 150\text{pF}$	24 27	32 35	40 45	48 54	
Maximum Output Disable Time, \overline{OC} to any Q	t_{PHZ}	$R_L = 1\text{k}\Omega$	19	25	31	37	ns	
	t_{PIZ}	$C_L = 50\text{pF}$	19	25	31	37		
Minimum Pulse Width, C High	t_w		6	10	12	15	ns	
Minimum Setup Time, D before C†	t_{su}		2	3	4	5	ns	
Minimum Hold Time, D after C†	t_h		6	10	12	15	ns	
Maximum Input Capacitance	C_{IN}		5				pF	
Maximum Output Capacitance	C_{OUT}	Output Disabled	10				pF	
Power Dissipation Capacitance* (per stage)	C_{PD}	$\overline{OC} = V_{CC}$	5				pF	
		$\overline{OC} = \text{GND}$	30					

* C_{PD} determines the no-load dynamic power dissipation: $P_D = C_{PD} V_{CC}^2 f + I_{CC} V_{CC}$.

† For AC switching test circuits and timing waveforms see section 2.



PACKAGE DIMENSIONS

T-90-20

1. PLASTIC PACKAGES

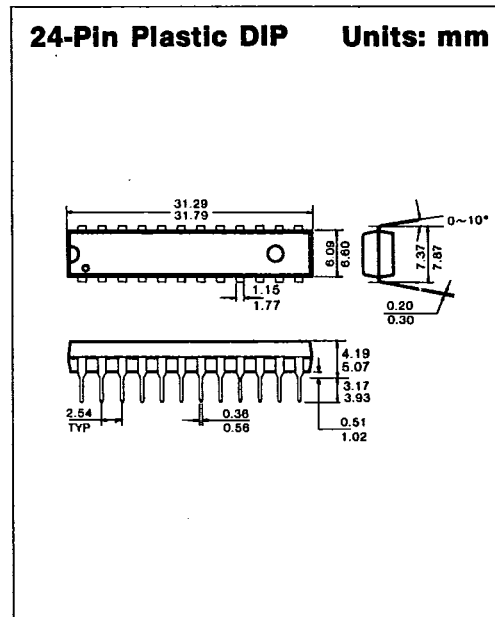
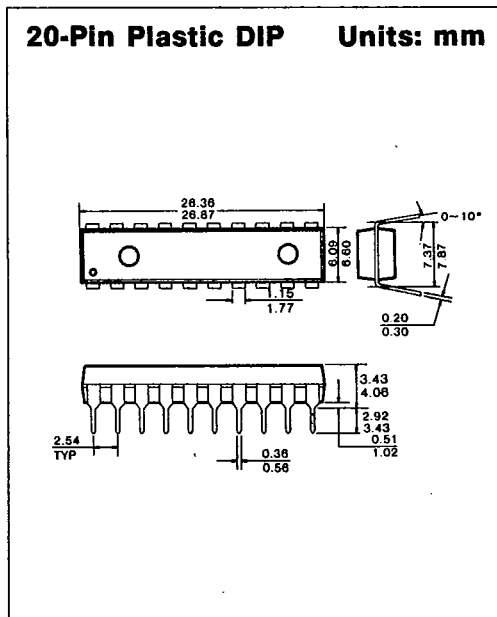
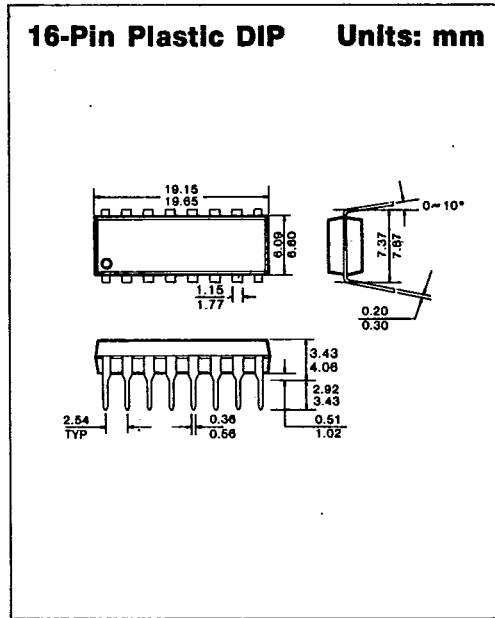
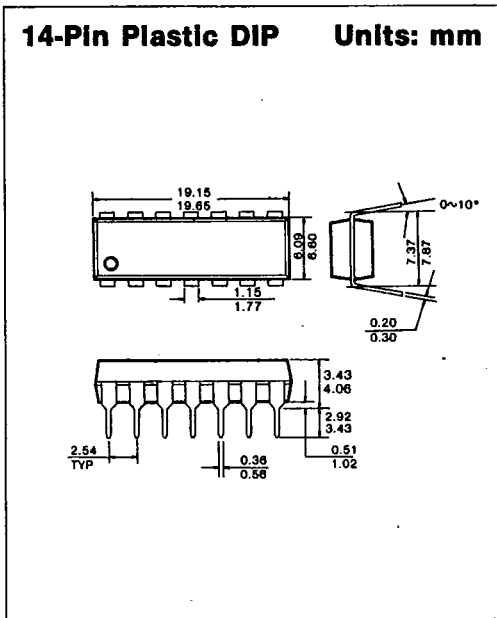

7



SAMSUNG SEMICONDUCTOR

1675

A-04

PACKAGE DIMENSIONS

T-90-20

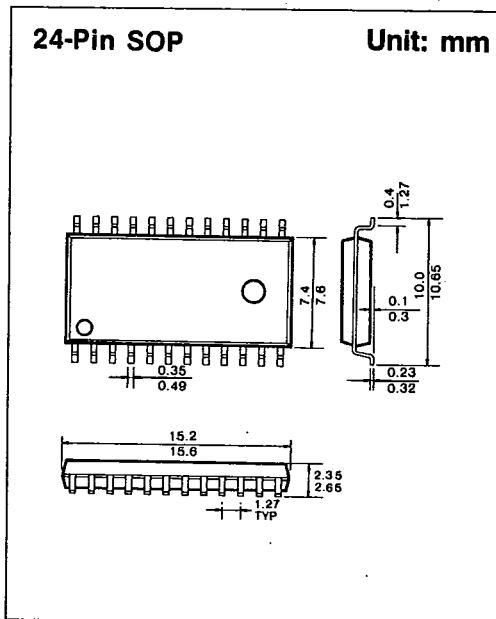
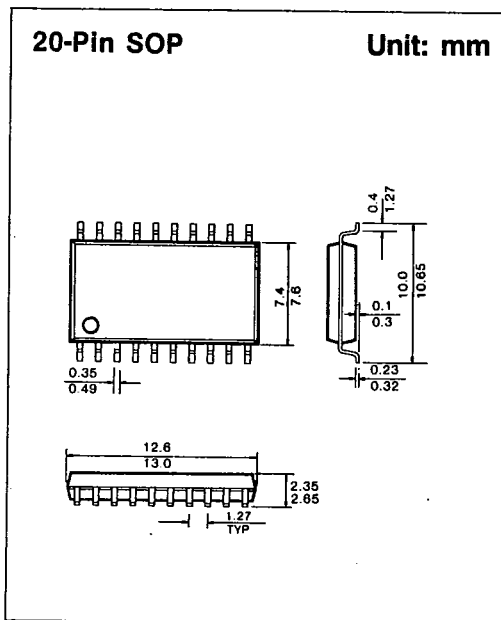
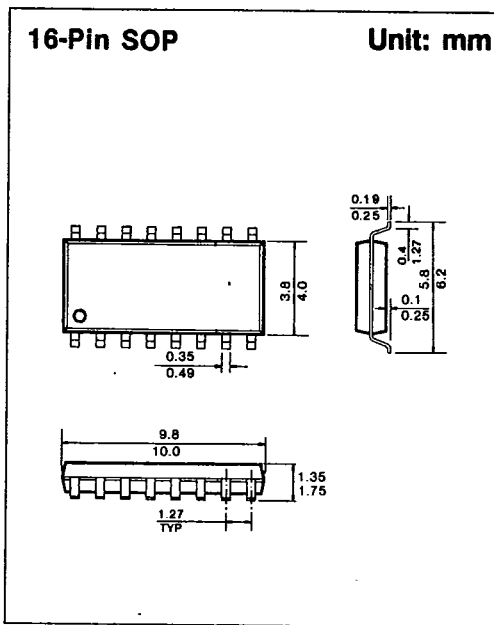
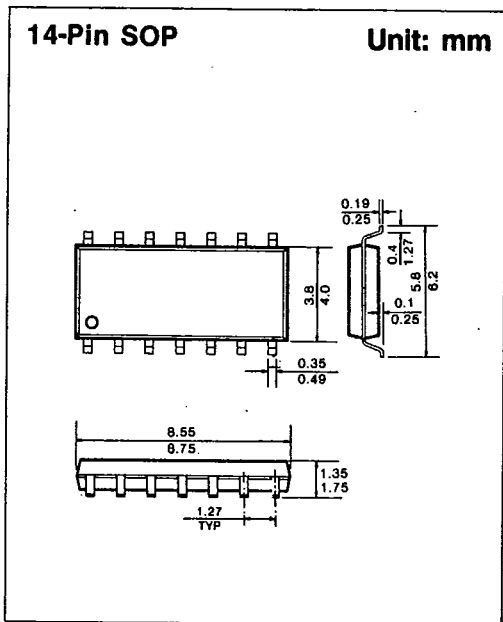

PACKAGE DIMENSIONS

T-90-20

2. CERAMIC PACKAGES

14-Pin Ceramic DIP Units: mm

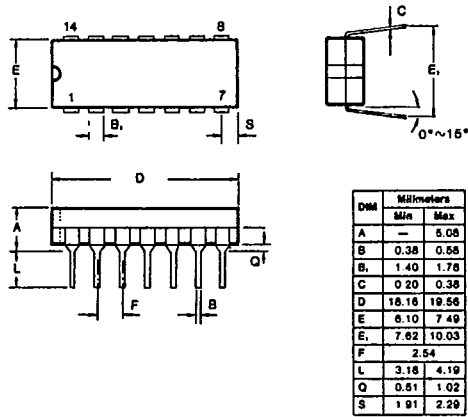

16-Pin Ceramic DIP Units: mm

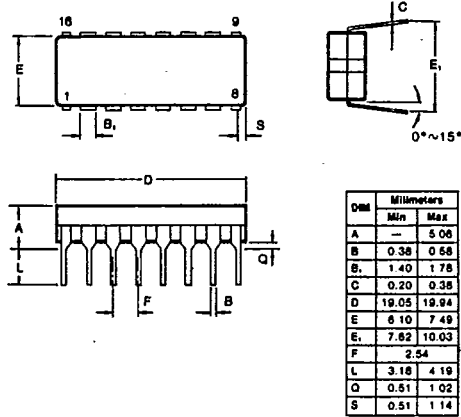

20-Pin Ceramic DIP Units: mm

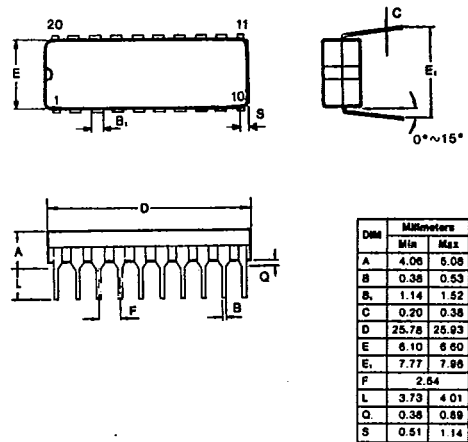

24-Pin Ceramic DIP Units: mm

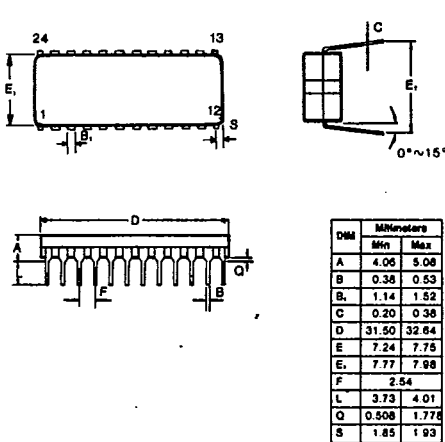

7