

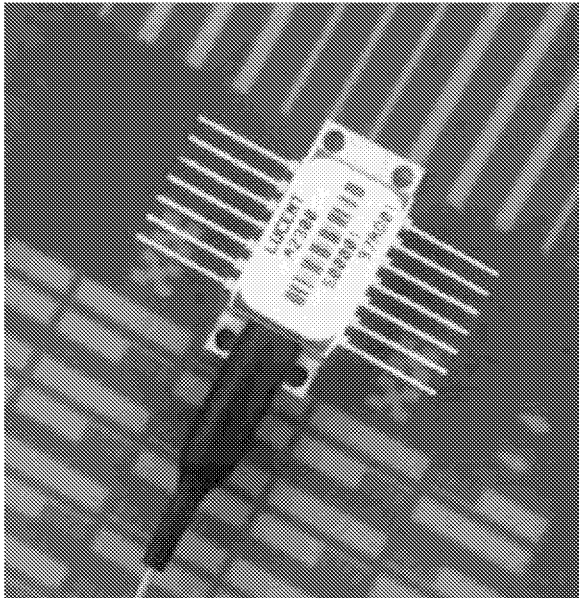

A2300-Type Laser 2000 Analog DFB Laser Module

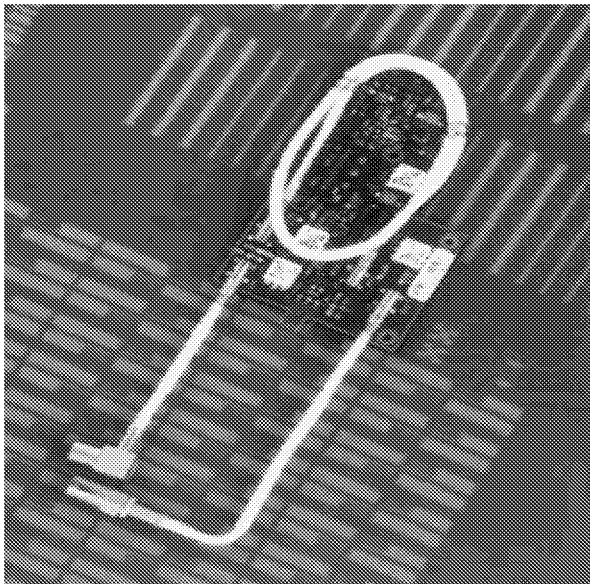

The A2300-Type, Analog, Isolated, Cooled, DFB Laser Module provides enhanced performance in analog transmission systems, with a variety of product options.



A separate predistortion board provides both CSO and CTB correction enhancements to the A2300-Type Laser Module performance, for 110 NTSC as well as 42 CENELEC channels.

Features

- High-performance, multiquantum-well (MQW), distributed-feedback (DFB), semiconductor laser.
- 14-pin, hermetic, butterfly-type package provides internal isolation and thermoelectric cooling/heating functions.
- Stable, accurate, PIN photodetector for laser back-facet optical output power monitoring/control.
- Operation at the low dispersion, 1310 nm wavelength.
- Stable performance over the wide temperature range of -20°C to $+65^{\circ}\text{C}$.
- Multiple product options available:
 - Stand-alone or predistorted.
 - 77/110 NTSC or 42 CENELEC test channel loading.
 - Simulated system testing available in a variety of fiber link budget losses.
 - $25\ \Omega$ resistive-matched or $75\ \Omega$ transformer-matched input impedances.
- Superior signal quality and system performance compared to present coaxial-based analog systems.

Applications

- Video surveillance
- CATV
- Wireless/personal communications networks and systems

Description

The Laser 2000, A2300-Type Analog, DFB Laser Module contains a high-performance, Indium Gallium Arsenide Phosphide, multi-quantum-well, distributed-feedback laser chip designed for 1310 nm, single-mode fiber-optic applications. The module is an industry-standard, 14-pin butterfly-type, hermetic, metal/ceramic package and houses the laser chip as well as an integral thermoelectric cooling/heating device, a thermistor, an integral optical isolator, and a laser back-faceted optical monitor. The module is also equipped with a 900 μm Hytrel* jacketed, 8.8 μm core, single-mode fiber and Lucent Technologies Microelectronics Group standard SC-type connector.

The integral thermoelectric cooler (TEC) provides stable thermal characteristics for the laser chip, as well as the optical isolator and back-faceted monitor. The TEC allows for heating and cooling of these internal optical components and can maintain their temperature at a constant 25 °C over the entire ambient operating temperature range of -20 °C to +65 °C. The thermistor monitors the internal module temperatures and provides feedback control for the TEC. This gives the A2300-Type Laser 2000 superior, stable optical characteristics.

When used in a fiber-optic system, reflected light entering the laser module is attenuated a minimum of 25 dB by the optical isolator. The internal PIN photodiode monitors the optical power emitted from the rear facet of the laser diode, and when used in conjunction with exterior module circuitry, it can monitor and control the optical output power launched into the fiber.

Lucent Technologies offers two different pinout types and RF drive impedance. The first is the Optoelectronics unit standard analog isolated laser module (ILM) pinout, formerly the ASTROTEC® 257-type, and has an input impedance of 75 Ω . The 75 Ω input impedance eliminates the need for external

matching circuits and is achieved using an RF transformer internal to the package. This allows the RF drive level into the laser to be typically 4 dB less than if resistive matching were used. The second pinout type, formerly the ASTROTEC 247-type, has a resistive input impedance of 25 Ω and matches the pinout of the optoelectronic industry's standard 2.5 Gbits/s package. This module offers the advantage of being a replacement for current competitive analog laser modules.

Lucent Technologies analog laser modules feature the ability to have enhanced performance and value through the addition of the Optoelectronics unit's exclusive predistortion board. The separate predistortion board provides both CSO and CTB correction enhancements to the laser module performance, for 110 NTSC as well as 42 CENELEC channels. While maintaining extremely low electrical power dissipation and low insertion loss, the predistortion board allows 1000 MHz of RF bandwidth.

Every A2300-type Laser 2000 module is tested to meet the customer's analog performance specifications, over the specified fiber link budget loss and test channel plan. This measurement method ensures proper system performance of the product. Lucent Technologies Optoelectronics unit components and products are qualified to the rigorous requirements of Bellcore Standards, ensuring that the optoelectronic performance will meet the needs of the application over the lifetime of the product.

* Hytrel is a registered trademark of E.I. DuPont de Nemours and Company.

Pin Information

Type 2

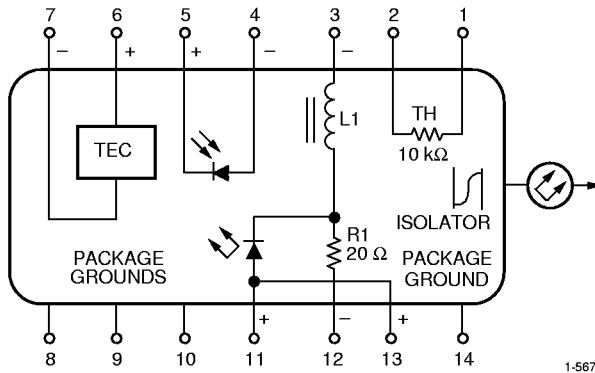

Figure 1. Circuit Schematic (Top View)
Industry-Standard (2.5 Gbits/s) Pinout,
25 Ω Resistive Input Impedance

Table 1. Type 2 Pin Descriptions

Pin	Connection
1	Thermistor.
2	Thermistor.
3	Laser (dc Bias) Cathode (-).
4	Back-facet Monitor Anode (-).
5	Back-facet Monitor Cathode (+).
6	Thermoelectric Cooler (+).*
7	Thermoelectric Cooler (-).*
8	Case Ground.†
9	Case Ground.†
10	Case Ground.†
11	Laser Anode (+).‡
12	RF Input; 25 Ω.§
13	Laser Anode (+).‡
14	Case Ground.†

* A positive current through the thermoelectric cooler cools the laser.
† Pins 8—10 and 14 must be grounded to RF ground.
‡ Both leads should be grounded for optimum performance.
§ For proper operation, pin 12 (RF input) must be dc decoupled.

- Benefits:
 - Pinout allows drop-in replacement for industry-competitive modules.

Type 3

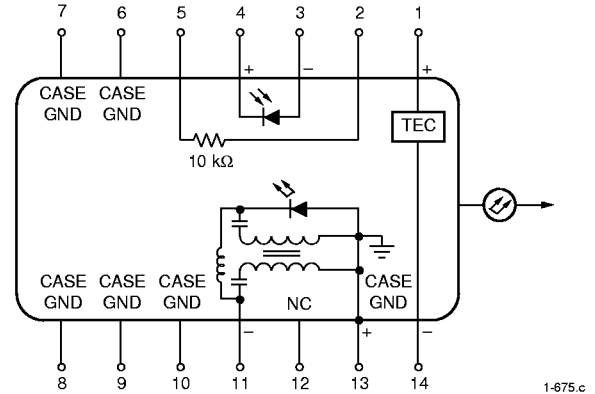

Figure 2. Circuit Schematic (Top View)
Lucent Technologies Standard Pinout,
75 Ω Transformer-Matched Input
Impedance

Table 2. Type 3 Pin Descriptions

Pin	Connection
1	Thermoelectric Cooler (+).*
2	Thermistor.
3	Back-facet Monitor Anode (-).
4	Back-facet Monitor Cathode (+).
5	Thermistor.
6	Case Ground.†
7	Case Ground.†
8	Case Ground.†
9	Case Ground.†
10	Case Ground.†
11	Laser (dc Bias) Cathode (-) and RF Input; 75 Ω Input.
12	No Connect.
13	Laser Anode (+), Case Ground.†
14	Thermoelectric Cooler (-).*

* A positive current through the thermoelectric cooler cools the laser.
† Pins 6—10 and 13 must be grounded to RF ground.

- Benefits:
 - Transformer allows for 4.0 dB reduction in required RF drive per channel.
 - No impedance matching circuitry required between output of hybrid amplifier and Lucent laser.

Predistortion Function Information

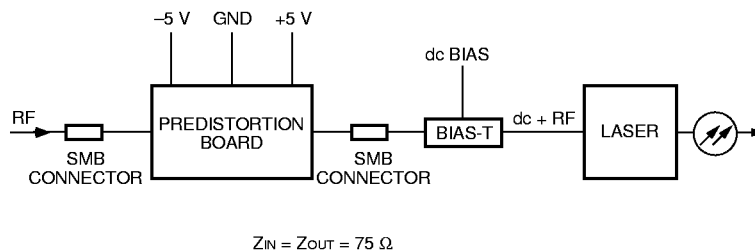

1-831

Figure 3. Laser and Predistortion PCB Solution Block Diagram

■ **Benefits:**

- Preselected laser matched to separate predistortion board optimizes customer system-level performance.
- Lucent Technologies provides predistortion circuitry, no customer design required.
- Compatible with Type 3.
- CSO and CTB distortion enhancements.

Part Numbering for the Laser 2000 A2300-Type

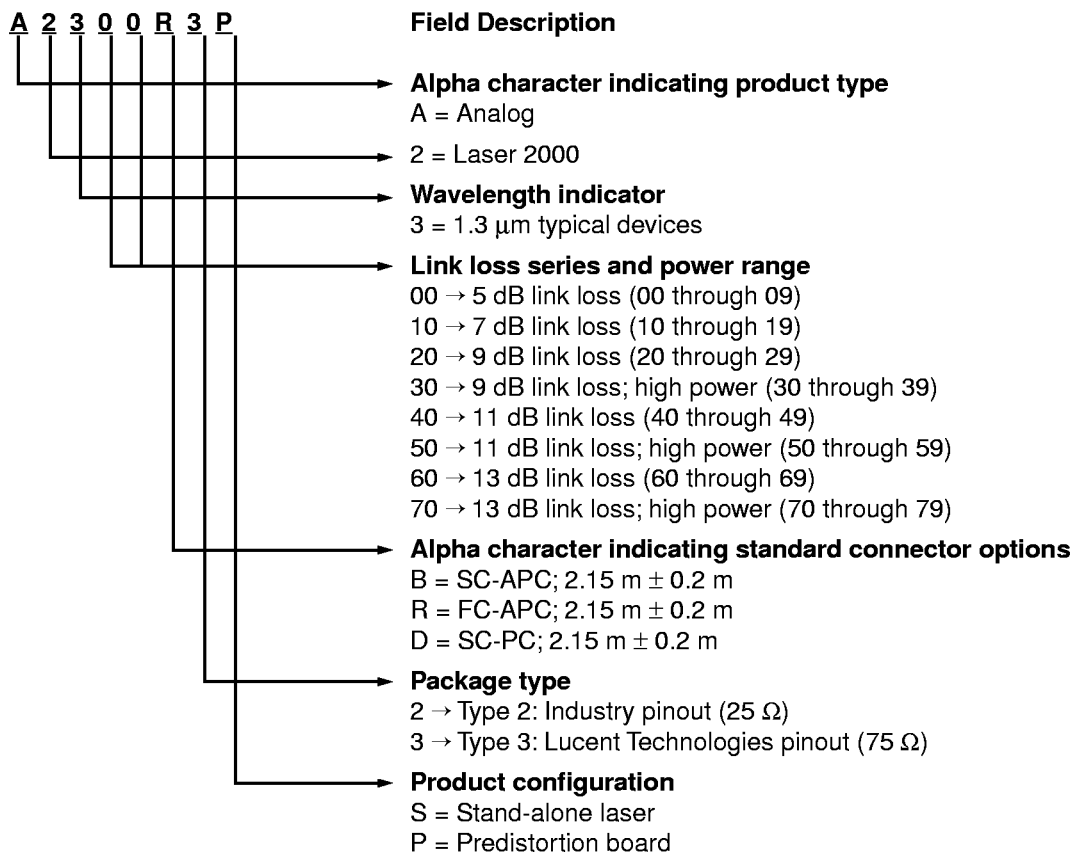

Handling Precautions

Mounting Instructions for Laser Module

The minimum fiber bend radius is 1.25 in. To avoid degradation in performance, mount the module on the board as follows:

1. Place the bottom flange of the module on a flat heat sink at least 0.5 in. x 1.180 in. (12.7 mm x 30 mm) in size. The surface finish of the heat sink should be better than 32 μm . (0.8 μm), and the surface flatness must be better than 0.001 in. (25.4 μm). The use of thermal conductive grease is optional; however, thermal performance can be improved by up to 5% if conductive grease is applied between the bottom flange and the heat sink.
2. Mount four #2-56 screws with Fillister heads (M2-3 mm) (see Figure 4) at the four screw-hole locations (see Outline Diagram). The Fillister head diameter must not exceed 0.140 in. (3.55 mm). Do not apply more than 1 in.-lb. of torque to the screws.

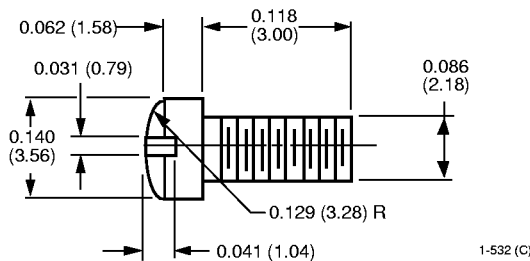

Note: Dimensions are in inches and (millimeters).

Figure 4. Fillister Head Screw

Power Sequencing

Adopt the following sequence for turn-on as a matter of good practice to avoid the possibility of damage to the laser module from power supply switching transients.

1. All ground connections.
2. Most negative supply.
3. Most positive supply.
4. All remaining connections.

Reverse the above order for the proper turn-off sequence.

Electrostatic Discharge

CAUTION: This device is susceptible to damage as a result of electrostatic discharge. Take proper precautions during both handling and testing. Follow guidelines such as JEDEC Publication No. 108-A (Dec. 1988).

Lucent employs a human-body model (HBM) for ESD-susceptibility testing and protection-design evaluation. ESD voltage thresholds are dependent on the critical parameters used to define the model. A standard HBM (resistance = 1.5 k Ω , capacitance = 100 pF) is widely used and, therefore, can be used for comparison purposes. The HBM ESD threshold presented here was obtained using these circuit parameters:

Parameter	Value	Unit
Human-body Model	400	V

Absolute Maximum Ratings

Stresses in excess of the absolute maximum ratings can cause permanent damage to the device. These are absolute stress ratings only. Functional operation of the device is not implied at these or any other conditions in excess of those given in the operations sections of the data sheet. Exposure to absolute maximum ratings for extended periods can adversely affect device reliability.

Parameter	Symbol	Min	Max	Unit
Laser Reverse Voltage	—	—	2	V
Laser dc Forward Current	—	—	150	mA
Predistortion Board dc Supply Voltage:				
Positive	—	—	+7	V
Negative	—	—	-7	V
RF Modulation per Channel (75 Ω)	—	—	0	dBm
Operating Temperature Range	T _A	-20	65	°C
Storage Case Temperature Range	T _{stg}	-40	85*	°C

* 2000 hours maximum.

Characteristics

Minimum and maximum values are testing requirements. Typical values are for informational purposes only and are not part of the testing requirements. Each device is provided with recommended operating conditions to achieve specified performance. $T_L = 25\text{ }^\circ\text{C}$, unless noted otherwise. Predistortion board supply voltage is $\pm 5\text{ V}$, $\pm 10\%$.

Table 3. Electrical Characteristics

Parameter	Symbol	Test Conditions	Min	Typ	Max	Unit
Laser Forward Voltage	V_{LF}	At rated power	—	1.3	1.8	V
Operating Current	I_{OP}	—	—	50	100	mA
Threshold Current	I_{TC}	*	—	10	40	mA
Monitor Reverse-bias Voltage	V_{MON}	—	3	—	10	V
Monitor Current	I_{MON}	At I_{OP}	0.2	—	2.0	mA
Monitor Dark Current	I_D	$I_F = 0$, $V_{MON} = 5\text{ V}$	—	—	0.10	μA
Thermistor Current	I_{TH}	—	10	—	100	μA
Thermistor Resistance	R_{TH}	$T_L = 25\text{ }^\circ\text{C}$, $I_{TH} \leq 0.1\text{ mA}$	9.5	—	10.5	$\text{k}\Omega$
Thermistor Thermal Characteristic	$\Delta R_{TH}/\Delta T_L$	$-25\text{ }^\circ\text{C} \leq T_L \leq 65\text{ }^\circ\text{C}^\dagger$	—	-4.4	—	$\%/^\circ\text{C}$
Thermistor Temperature Coefficient	B	—	3700	3900	4100	K
TEC Current	I_{TEC}	$\Delta T = 40\text{ }^\circ\text{C}$	—	—	1.0	A
TEC Voltage	V_{TEC}	$\Delta T = 40\text{ }^\circ\text{C}$	—	—	1.8	V
TEC Cooling Capacity	ΔT	—	40	—	—	$^\circ\text{C}$

* The laser threshold current is the current at which the first derivative of the laser light vs. forward current is at one-half of its maximum.

† The thermistor thermal characteristic will be monotonic.

Table 4. Optical Characteristics

Parameter	Symbol	Test Conditions	Min	Typ	Max	Unit
Optical Output Power	P_O	—	3.0	—	20.0	mW
Center Wavelength	λ_C	—	1290	1310	1330	nm
Optical Isolation	—	$-20\text{ }^\circ\text{C}$ to $+65\text{ }^\circ\text{C}$	25	—	—	dB
Side-mode Suppression Ratio	SMSR	Modulated	30	—	—	dB

Predistortion Board

Dimensions are in inches and (millimeters). Tolerances are ± 0.005 in. unless noted otherwise.

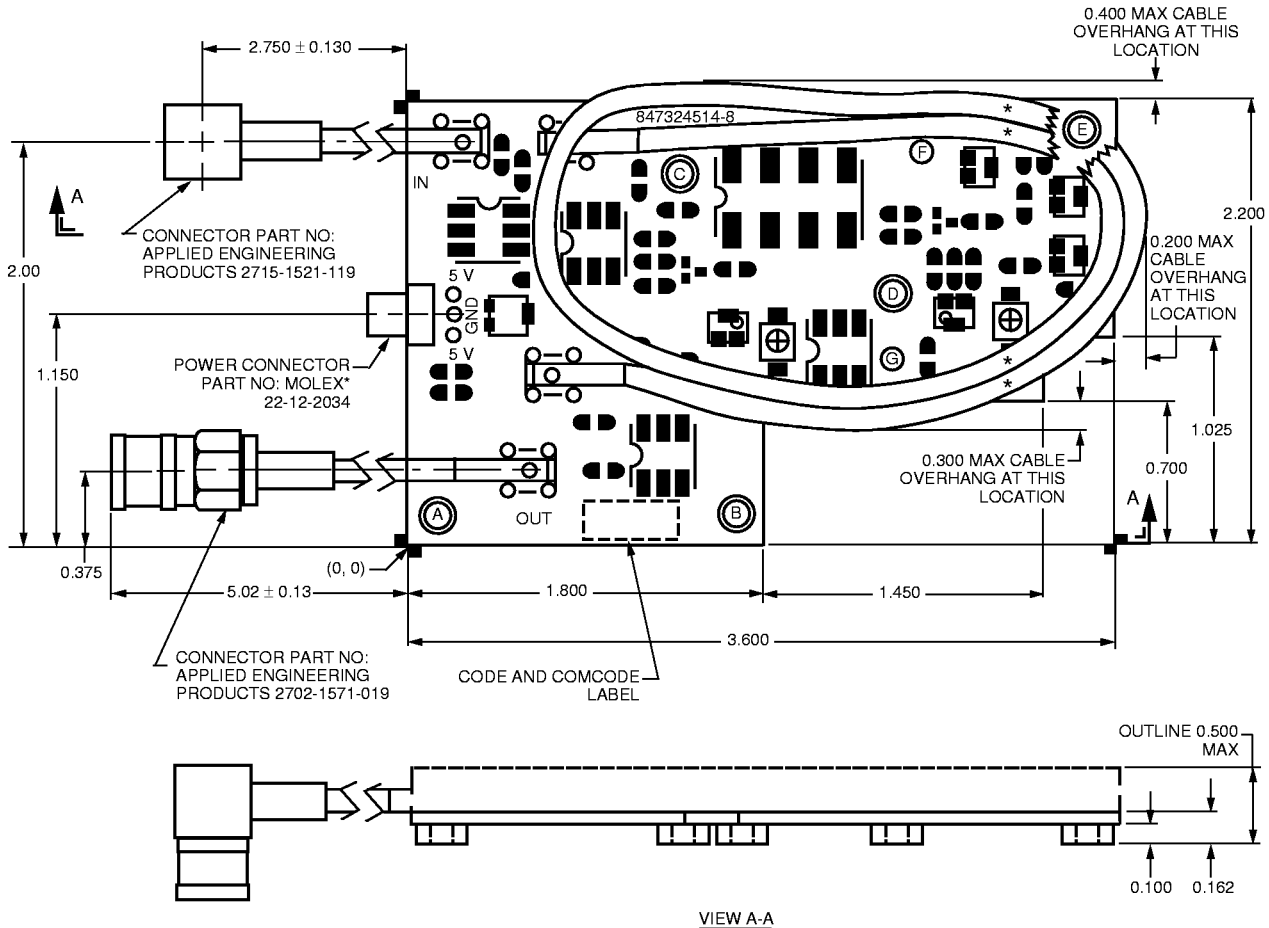

VIEW A-A

1-830 (C)

* Molex is a registered trademark of Molex, Inc.

Notes:

Mating connectors from Applied Engineering Products:

PWB mounted straight—2709-1511-001

PWB mounted right angle—2710-1511-000

Cable connector—2701-1571-019

Centerline hole position from (0,0). All holes are unplated.

Designation	Inner Diameter	X	Y
A	0.116	0.150	0.150
B	0.116	1.650	0.150
C	0.116	1.380	1.850
D	0.116	2.450	1.250
E	0.116	3.450	2.050
F	—	2.600	1.955
G	—	2.450	0.925

A spacer is inserted in holes A, B, C, D, and E. The diameter listed is the inner diameter of the spacer.

Laser Safety Information

Class IIIb Laser Product

This product complies with 21 CFR 1040.10 and 1040.11.

Single-mode connector

Wavelength = 1.3 μm

Maximum power = 40 mW

Because of size constraints, laser safety labeling is not affixed to the module but is contained on the shipping carton.

Product is not shipped with power supply.

CAUTION: Use of controls, adjustments, and procedures other than those specified herein may result in hazardous laser radiation exposure.

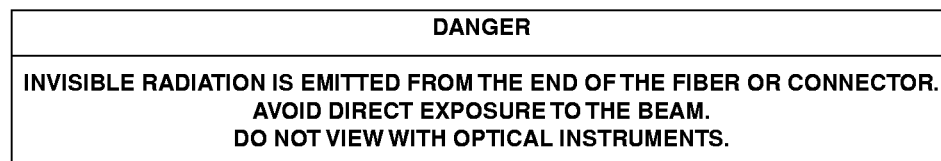
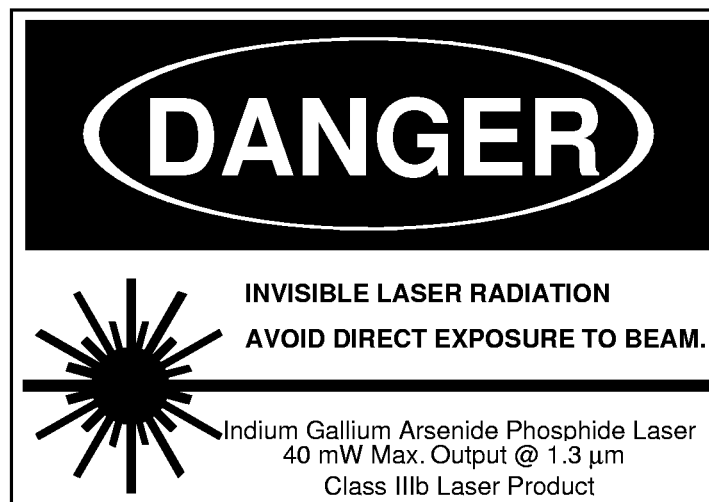

Ordering Information

Table 5. Analog Product Availability

Old ILM Code	L2000 Part No.	Comcode	Tested Loss*	Optical Power	Channel Capacity	CNR (dBc)	CSO (dBc)	CTB (dBc)	Product Configuration†	
Stand-Alone Short-Haul Lasers										
257EH	A2320D75	108116708	5 dB	<6 mW	77 NTSC	52	-62	-67	—	Type 3
257RH	A2333D75	108116690	5 dB	2 mW— 3 mW	77 NTSC	4	-61	-50	—	Type 3
257ABH	A2303D75	108116740	7 dB	2.5 mW— 6.5 mW	77 NTSC	43	-61	-67	—	Type 3
—	A2312R3S	108235706	7 dB	<6 mW	77 NTSC	51	-61	-67	—	Type 3
A57AFH	A2307D75	108116732	7 dB	4 mW — 6.5 mW	77 NTSC	51	-63	-67	—	Type 3
Stand-Alone Long-Haul Lasers										
257CH	A2315D75	108116716	11 dB	>4 mW	77 NTSC	48	-61	-67	—	Type 3
—	A2351B2S	108161365	11 dB	>10 mW	42 CENELEC	50	-62	-67	Type 2	—
Predistorted Short-Haul Lasers										
—	A2313B3P	108075326	7 dB	5mW— 7 mW	42 CENELEC	52	-63	-67	—	Type 3
—	A2336B3P	108161373	9 dB	7 mW— 9 mW	42 CENELEC	52	-63	-67	—	Type 3
Predistorted Long-Haul Lasers										
257KP (>10 mW)	A2352R3P	108066739	11 dB	>10 mW	77 NTSC	52	-61	-67	—	Type 3
257PP	A2334D7P	108116724	11 dB	>6 mW	77 NTSC	52	-62	-67	—	Type 3
257RP	A2335D7P	108116682	11 dB	>4 mW	77 NTSC	51	-62	-67	—	Type 3
—	A2343B3P	108168220	11 dB	>6 mW	42 CENELEC	52	-63	-67	—	Type 3
—	A2353B3P	108132382	11 dB	9 mW— 11 mW	42 CENELEC	52	-63	-67	—	Type 3
—	A2354B3P	108132390	11 mW	10 mW— 12 mW	42 CENELEC	52	-63	-67	—	Type 3
—	A2357B3P	108230541	11 dB	12 mW— 14 mW	42 CENELEC	52	-63	-67	—	Type 3
—	A2365R3P	108028044	13 dB	>8 mW	77 NTSC	52	-63	-69	—	Type 3
—	A2366R3P	108028390	13 dB	>8 mW	110 NTSC	51	-63	-69	—	Type 3
—	A2363B3P	108230558	13 dB	15 mW— 17 mW	42 CENELEC	52	-63	-67	—	Type 3

* 5 dB, all fiber; 7 dB, all fiber; 9 dB includes 2 dB passive loss; 11 dB includes 2 dB passive loss; 13 dB includes 4 dB passive loss.

† Type 2: industry-standard pinout (2.5 Gbits/s type) and a 25 Ω input impedance (resistive). Type 3: Lucent pinout and a 75 Ω input impedance (transformer matched).

Note: Some codes do not conform to the standard ADN configuration scheme. An ADN that ends with D75 denotes a stand-alone module, Type-3 pinout.