

**TYPES SN5496, SN54L96, SN54LS96,
SN7496, SN74L96, SN74LS96
5-BIT SHIFT REGISTERS**

BULLETIN NO. DL-S 7611821, MARCH 1974—REVISED OCTOBER 1976

- N-Bit Serial-To-Parallel Converter
- N-Bit Parallel-To-Serial Converter
- N-Bit Storage Register

TYPE	TYPICAL	
	PROPAGATION DELAY TIME	POWER DISSIPATION
'96	25 ns	240 mW
'L96	50 ns	120 mW
'LS96	25 ns	60 mW

description

These shift registers consist of five R-S master-slave flip-flops connected to perform parallel-to-serial or serial-to-parallel conversion of binary data. Since both inputs and outputs for all flip-flops are accessible, parallel-in/parallel-out or serial-in/serial-out operation may be performed.

All flip-flops are simultaneously set to a low output level by applying a low-level voltage to the clear input while the preset is inactive (low). Clearing is independent of the level of the clock input.

The register may be parallel loaded by using the clear input in conjunction with the preset inputs. After clearing all stages to low output levels, data to be loaded is applied to the individual preset inputs (A, B, C, D, and E) and a high-level load pulse is applied to the preset enable input. Presetting like clearing is independent of the level of the clock input.

Transfer of information to the outputs occurs on the positive-going edge of the clock pulse. The proper information must be set up at the R-S inputs of each flip-flop prior to the rising edge of the clock input waveform. The serial input provides this information to the first flip-flop, while the outputs of the subsequent flip-flops provide information for the remaining R-S inputs. The clear input must be high and the preset or preset enable inputs must be low when clocking occurs.

SN5496, SN54L96 . . . J OR W PACKAGE
SN54L96 . . . J PACKAGE
SN7496, SN74L96, SN74LS96 . . . J OR N PACKAGE
(TOP VIEW)

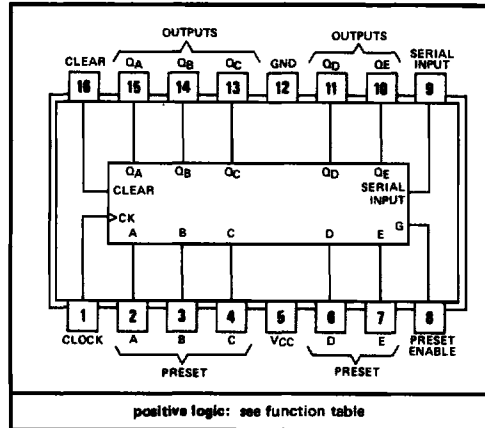

positive logic: see function table

FUNCTION TABLE

CLEAR	PRESET ENABLE	INPUTS					CLOCK	SERIAL	OUTPUTS				
		PRESET							QA	QB	QC	QD	QE
		A	B	C	D	E							
L	L	X	X	X	X	X	X	L	L	L	L	L	
L	X	L	L	L	L	L	X	X	L	L	L	L	
H	H	H	H	H	H	H	X	X	H	H	H	H	
H	H	L	L	L	L	L	L	X	QA0	QB0	QC0	QD0	QE0
H	H	H	L	H	L	H	L	X	H	QB0	H	QD0	H
H	L	X	X	X	X	X	L	X	QA0	QB0	QC0	QD0	QE0
H	L	X	X	X	X	X	↑	H	H	QA _n	QB _n	QC _n	QD _n
H	L	X	X	X	X	X	↑	L	L	QA _n	QB _n	QC _n	QD _n

H = high level (steady state), L = low level (steady state)
 X = irrelevant (any input, including transitions)
 ↑ = transition from low to high level
 QA0, QB0, etc = the level of QA, QB, etc, respectively before the indicated steady-state input conditions were established.
 QA_n, QB_n, etc = the level of QA, QB, etc, respectively before the most-recent ↑ transition of the clock.

TYPES SN5496, SN54L96, SN54LS96, SN7496, SN74L96, SN74LS96 5-BIT SHIFT REGISTERS

typical clear, shift, preset, and shift sequences

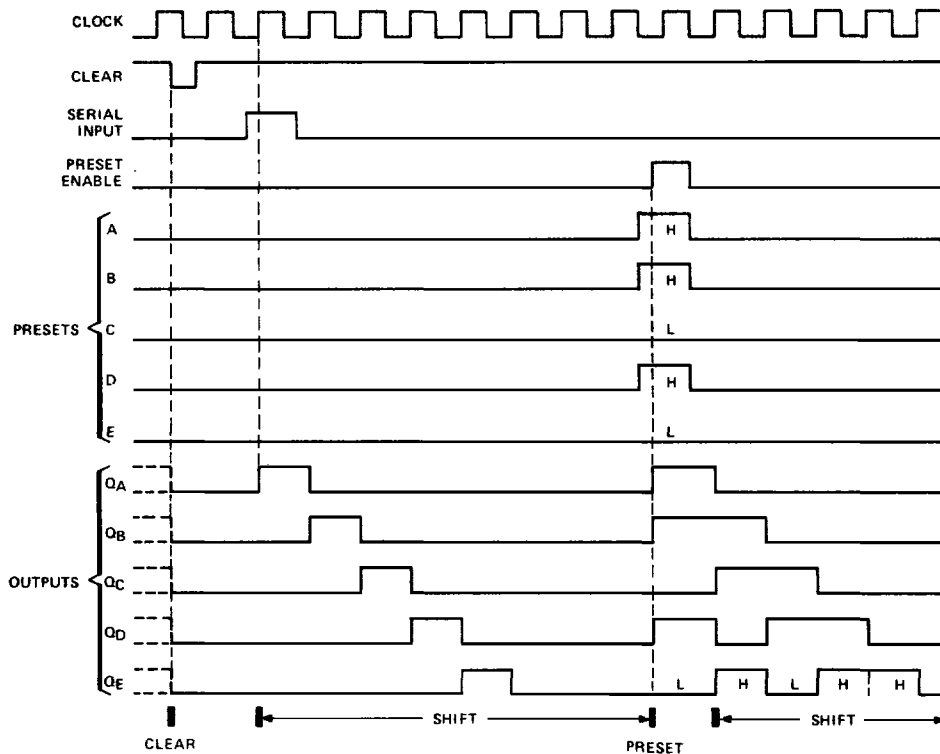

functional block diagram

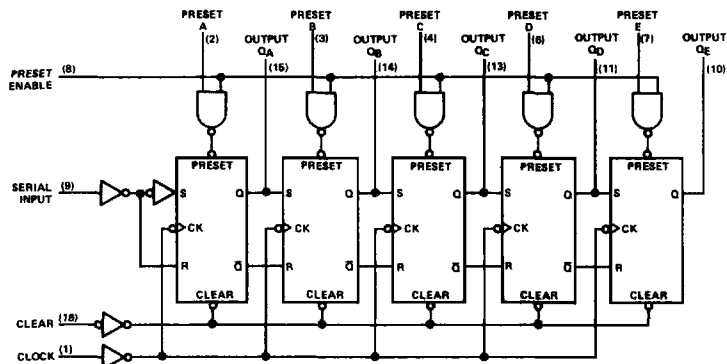

. . . dynamic input activated by transition from a high level to a low level.

**TYPES SN5496, SN54L96, SN54LS96,
SN7496, SN74L96, SN74LS96
5-BIT SHIFT REGISTERS**

REVISED OCTOBER 1976

schematics of inputs and outputs

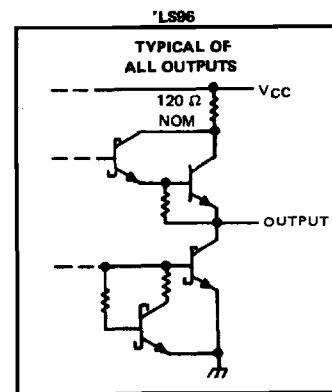
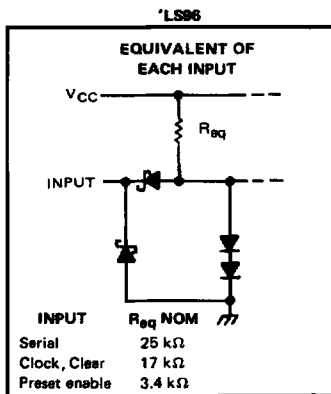
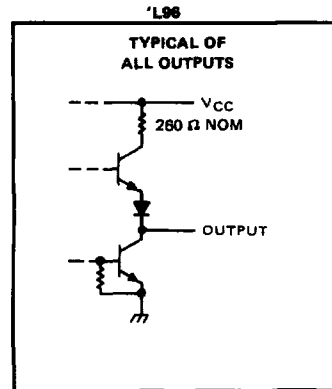
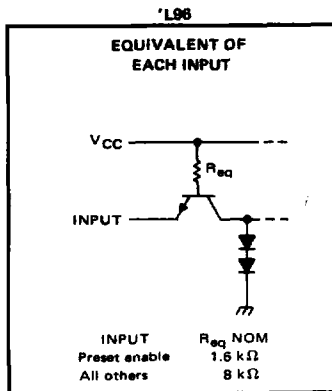
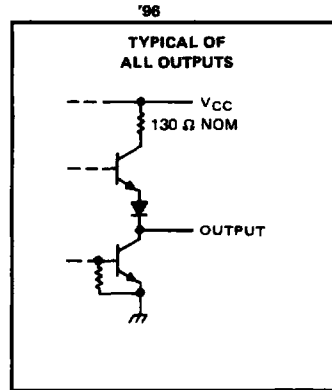
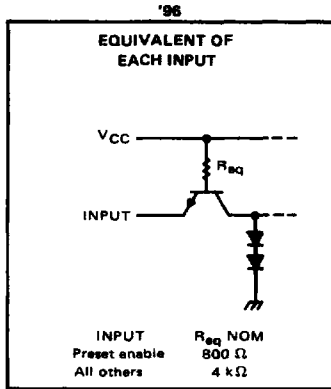

TYPES SN5496, SN7496

5-BIT SHIFT REGISTERS

absolute maximum ratings over operating free-air temperature range (unless otherwise noted)

Supply voltage, V_{CC} (see Note 1)	7 V
Input voltage (see Note 2)	5.5 V
Operating free-air temperature range: SN5496	-55°C to 125°C
SN7496	0°C to 70°C
Storage temperature range	-65°C to 150°C

NOTES: 1. Voltage values are with respect to network ground terminal.
2. Input voltages must be zero or positive with respect to network ground terminal.

recommended operating conditions

	SN5496			SN7496			UNIT
	MIN	NOM	MAX	MIN	NOM	MAX	
Supply voltage, V_{CC}	4.5	5	5.5	4.75	5	5.25	V
High-level output current, I_{OH}			-400			-400	μ A
Low-level output current, I_{OL}			16			16	mA
Clock frequency, f_{clock}	0	10	0	10	10	10	MHz
Width of clock input pulse, $t_{w(clock)}$	35			35			ns
Width of preset and clear input pulse, t_w	30			30			ns
Serial input setup time, t_{SU} (see Figure 1)	30			30			ns
Serial input hold time, t_H (see Figure 1)	0			0			ns
Operating free-air temperature, T_A	-55	125	0	70			°C

electrical characteristics over recommended operating free-air temperature range (unless otherwise noted)

PARAMETER		TEST CONDITIONS†	SN5496			SN7496			UNIT
			MIN	TYP‡	MAX	MIN	TYP‡	MAX	
V_{IH}	High-level input voltage		2			2			V
V_{IL}	Low-level input voltage				0.8			0.8	V
V_{OH}	High-level output voltage	$V_{CC} = \text{MIN}$, $V_{IH} = 2 \text{ V}$, $V_{IL} = 0.8 \text{ V}$, $I_{OH} = -400 \mu\text{A}$	2.4	3.4		2.4	3.4		V
V_{OL}	Low-level output voltage	$V_{CC} = \text{MIN}$, $V_{IH} = 2 \text{ V}$, $V_{IL} = 0.8 \text{ V}$, $I_{OL} = 16 \text{ mA}$		0.2	0.4		0.2	0.4	V
I_I	Input current at maximum input voltage	$V_{CC} = \text{MAX}$, $V_I = 5.5 \text{ V}$			1			1	mA
I_{IH}	High-level input current	any input except preset enable			40			40	μ A
		preset enable			200			200	
I_{IL}	Low-level input current	any input except preset enable			-1.6			-1.6	mA
		preset enable			-8			-8	
I_{OS}	Short-circuit output current§	$V_{CC} = \text{MAX}$	-20	-57	-18	-57		mA	
I_{CC}	Supply current	$V_{CC} = \text{MAX}$, See Note 3	48	68	48	79		mA	

† For conditions shown at MIN or MAX, use the appropriate value specified under recommended operating conditions.

‡ All typical values are at $V_{CC} = 5 \text{ V}$, $T_A = 25^\circ\text{C}$.

§ Not more than one output should be shorted at a time.

NOTE 3: I_{CC} is measured with the clear input grounded and all other inputs and outputs open.

switching characteristics, $V_{CC} = 5 \text{ V}$, $T_A = 25^\circ\text{C}$

PARAMETER	TEST CONDITIONS	MIN	TYP	MAX	UNIT
t_{PLH}	Propagation delay time, low-to-high-level output from clock		25	40	ns
t_{PHL}	Propagation delay time, high-to-low-level output from clock	$C_L = 15 \text{ pF}$,	25	40	ns
t_{PLH}	Propagation delay time, low-to-high-level output from preset or preset enable	$R_L = 400 \Omega$,	28	35	ns
t_{PHL}	Propagation delay time, high-to-low-level output from clear	See Figure 1		55	ns

TYPES SN54L96, SN74L96 5-BIT SHIFT REGISTERS

absolute maximum ratings over operating free-air temperature range (unless otherwise noted)

Supply voltage, V_{CC} (see Note 1)	7 V
Input voltage (see Note 2)	5.5 V
Operating free-air temperature range: SN54L96	-55°C to 125°C
SN74L96	0°C to 70°C
Storage temperature range	-65°C to 150°C

NOTES: 1. Voltage values are with respect to network ground terminal.
2. Input voltage must be zero or positive with respect to network ground terminal.

recommended operating conditions

	SN54L96			SN74L96			UNIT
	MIN	NOM	MAX	MIN	NOM	MAX	
Supply voltage, V_{CC}	4.5	5	5.5	4.75	5	5.25	V
High-level output current, I_{OH}			-200			-200	μ A
Low-level output current, I_{OL}			8			8	mA
Clock frequency, f_{clock}	0		5	0		5	MHz
Width of clock, preset, or clear input pulse, t_w	100			100			ns
Serial input setup time, t_{su} (see Figure 1)	100			100			ns
Serial input hold time, t_h (see Figure 1)	0			0			ns
Operating free-air temperature, T_A	-55		125	0		70	°C

electrical characteristics over recommended operating free-air temperature range (unless otherwise noted)

PARAMETER		TEST CONDITIONS†	SN54L96			SN74L96			UNIT
			MIN	TYP‡	MAX	MIN	TYP‡	MAX	
V_{IH}	High-level input voltage		2			2			V
V_{IL}	Low-level input voltage				0.8			0.8	V
V_{OH}	High-level output voltage	$V_{CC} = \text{MIN}$, $V_{IH} = 2 \text{ V}$, $V_{IL} = 0.8 \text{ V}$, $I_{OH} = -200 \mu\text{A}$	2.4	3.2		2.4	3.2		V
V_{OL}	Low-level output voltage	$V_{CC} = \text{MIN}$, $V_{IH} = 2 \text{ V}$, $V_{IL} = 0.8 \text{ V}$, $I_{OL} = 8 \text{ mA}$		0.2	0.4		0.2	0.4	V
I_I	Input current at maximum input voltage	$V_{CC} = \text{MAX}$, $V_I = 5.5 \text{ V}$			1			1	mA
I_{IH}	High-level input current	any input except preset enable			20			20	μ A
		preset enable			100			100	
I_{IL}	Low-level input current	any input except preset enable			-0.8			-0.8	mA
		preset enable			-4			-4	
		preset enable			-29			-29	
I_{OS}	Short-circuit output current §	$V_{CC} = \text{MAX}$	-10		-29			-9	mA
I_{CC}	Supply current	$V_{CC} = \text{MAX}$, See Note 3		24	34		24	40	mA

† For conditions shown at MIN or MAX, use the appropriate value specified under recommended operating conditions.

‡ All typical values are at $V_{CC} = 5 \text{ V}$, $T_A = 25^\circ\text{C}$.

§ Not more than one output should be shorted at a time.

NOTE 3: I_{CC} is measured with the clear input grounded and all other inputs and outputs open.

switching characteristics, $V_{CC} = 5 \text{ V}$, $T_A = 25^\circ\text{C}$

PARAMETER	TEST CONDITIONS	MIN	TYP	MAX	UNIT
t_{PLH}	Propagation delay time, low-to-high-level output from clock		50	80	ns
t_{PHL}	Propagation delay time, high-to-low-level output from clock		50	80	ns
t_{PLH}	Propagation delay time, low-to-high-level output from preset or preset enable		56	70	ns
t_{PHL}	Propagation delay time, high-to-low-level output from clear			110	ns

$C_L = 15 \text{ pF}$,
 $R_L = 800 \Omega$,
See Figure 1

TYPES SN54LS96, SN74LS96

5-BIT SHIFT REGISTERS

REVISED AUGUST 1977

absolute maximum ratings over operating free-air temperature range (unless otherwise noted)

Supply voltage, V_{CC} (see Note 1)	7 V
Input voltage	7 V
Operating free-air temperature range: SN54LS96	-55°C to 125°C
SN74LS96	0°C to 70°C
Storage temperature range	-65°C to 150°C

NOTE 1: Voltage values are with respect to network ground terminal.

recommended operating conditions

	SN54LS96			SN74LS96			UNIT
	MIN	NOM	MAX	MIN	NOM	MAX	
Supply voltage, V_{CC}	4.5	5	5.5	4.75	5	5.25	V
High-level output current, I_{OH}			-400			-400	μ A
Low-level output current, I_{OL}			4			8	mA
Clock frequency, f_{clock}	0		25	0		25	MHz
Width of clock input pulse, $t_w(clock)$			20			20	ns
Width of preset and clear input pulse, t_w			30			30	ns
Serial input setup time, t_{setup} (see Figure 1)			30			30	ns
Serial input hold time, t_{hold} (see Figure 1)			0			0	ns
Operating free-air temperature, T_A	-55		125	0		70	°C

electrical characteristics over recommended operating free-air temperature range (unless otherwise noted)

PARAMETER		TEST CONDITIONS†	SN54LS96			SN74LS96			UNIT	
			MIN	TYP‡	MAX	MIN	TYP‡	MAX		
V_{IH}	High-level input voltage		2			2			V	
V_{IL}	Low-level input voltage				0.7			0.8	V	
V_{IK}	Input clamp voltage	$V_{CC} = \text{MIN}$, $I_I = -18 \text{ mA}$			-1.5			-1.5	V	
V_{OH}	High-level output voltage	$V_{CC} = \text{MIN}$, $V_{IH} = 2 \text{ V}$, $V_{IL} = V_{IL \text{ max}}$, $I_{OH} = -400 \mu\text{A}$	2.5	3.5		2.7	3.5		V	
V_{OL}	Low-level output voltage	$V_{CC} = \text{MIN}$, $V_{IH} = 2 \text{ V}$, $V_{IL} = V_{IL \text{ max}}$			0.25	0.4		0.25	0.4	V
		$I_{OL} = 4 \text{ mA}$						0.35	0.5	
I_I	Input current at maximum input voltage	Preset enable			0.5			0.5	mA	
		All others	$V_{CC} = \text{MAX}$, $V_I = 7 \text{ V}$			0.1		0.1		
I_{IH}	High-level input current	Preset enable			100			100	μ A	
		All others	$V_{CC} = \text{MAX}$, $V_I = 2.7 \text{ V}$			20		20		
I_{IL}	Low-level input current	Preset enable			-2			-2	mA	
		All others	$V_{CC} = \text{MAX}$, $V_I = 0.4 \text{ V}$			-0.4		-0.4		
I_{OS}	Short-circuit output current§	$V_{CC} = \text{MAX}$	-20		-100	-20		-100	mA	
I_{CC}	Supply current	$V_{CC} = \text{MAX}$, See Note 3		12	20		12	20	mA	

† For conditions shown at MIN or MAX, use the appropriate value specified under recommended operating conditions.

‡ All typical values are at $V_{CC} = 5 \text{ V}$, $T_A = 25^\circ\text{C}$.

§ Not more than one output should be shorted at a time, and duration of the short-circuit should not exceed one second.

NOTE 3: I_{CC} is measured with the clear input grounded and all other inputs and outputs open.

switching characteristics, $V_{CC} = 5 \text{ V}$, $T_A = 25^\circ\text{C}$

PARAMETER		TEST CONDITIONS	MIN	TYP	MAX	UNIT
t_{PLH}	Propagation delay time, low-to-high-level output from clock		$C_L = 15 \text{ pF}$, $R_L = 2 \text{ k}\Omega$, See Figure 1		25	40
t_{PHL}	Propagation delay time, high-to-low-level output from clock			25	40	ns
t_{PLH}	Propagation delay time, low-to-high-level output from preset or preset enable			28	36	ns
t_{PHL}	Propagation delay time, high-to-low-level output from clear				55	ns

**TYPES SN5496, SN54L96, SN54LS96,
SN7496, SN74L96, SN74LS96
5-BIT SHIFT REGISTERS**

PARAMETER MEASUREMENT INFORMATION

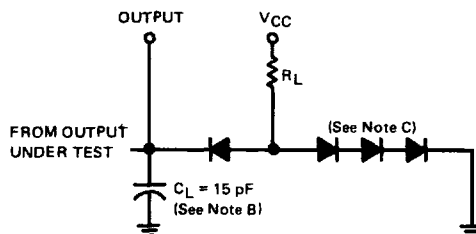

LOAD CIRCUIT

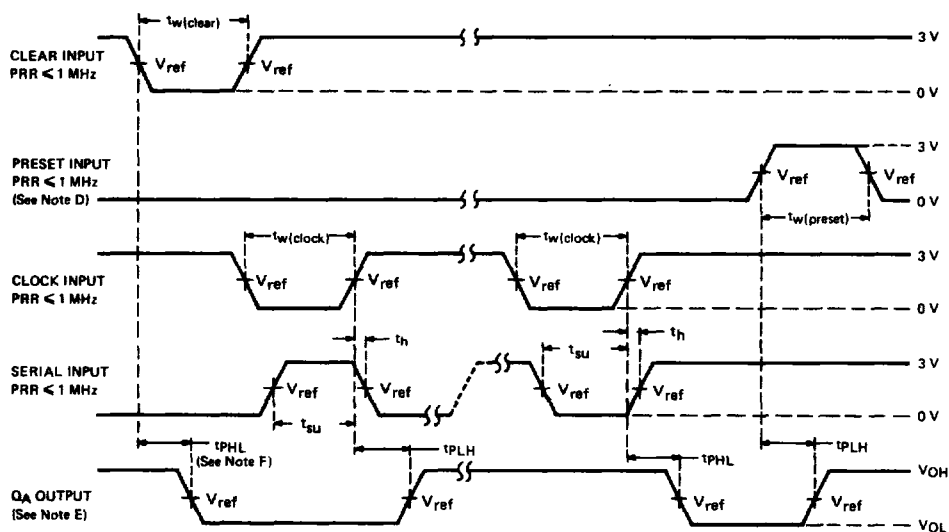

VOLTAGE WAVEFORMS

- NOTES:**
- A. Input pulses are supplied by pulse generators having the following characteristics: duty cycle $\leq 50\%$, $Z_{out} \approx 50 \Omega$; for '96 and 'L96, $t_r \leq 10$ ns, $t_f \leq 10$ ns, and for 'LS96 $t_r = 15$ ns, $t_f = 6$ ns.
 - B. C_L includes probe and jig capacitance.
 - C. All diodes are 1N3064 or 1N918.
 - D. Preset may be tested by applying a high-level voltage to the individual preset inputs and pulsing the preset enable or by applying a high-level voltage to the preset enable and pulsing the individual preset inputs.
 - E. Q_A output is illustrated. Relationship of serial input to other Q outputs is illustrated in the typical shift sequence.
 - F. Outputs are set to the high level prior to the measurement of t_{PHL} from the clear input.
 - G. For '96 and 'L96, $V_{ref} = 1.5$ V; for 'LS96 $V_{ref} = 1.3$ V.

FIGURE 1—SWITCHING TIMES