

Description

The μPD98501 has a high-performance 100 MHz MIPS® CPU as its host processor, an ATM cell processor for DSL access, a communication device class USB controller, and dual 10/100 Mbps Ethernet controllers. The ATM cell processor supports ATM adaptation layer (AAL) 0/2/5 and can handle 16 voice channels in parallel with Internet data access. The dual-channel Ethernet controller can be used in a variety of applications, such as in a SOHO router application where one channel is used for the WAN web server outside a firewall and the other channel is for the firewall-protected LAN.

Features

- ❑ High-performance V_R4120A™ 64-bit MIPS RISC processor
- ❑ Real-time operating system and network middleware on chip
- ❑ Direct connection to 16 Mb, 64 Mb, and 128 Mb SDRAM as external memory
- ❑ PROM and flash ROM interface for storing boot program
- ❑ 32-bit RISC controller as ATM cell processor
- ❑ Software SAR processing by RISC controller for flexible specification update (can support AAL 0/2/5)
- ❑ Four service classes: CBR, VBR, ABR, and UBR
- ❑ Two-channel 10/100 Mbps Ethernet controllers compliant with IEEE 802.3, 802.3u, and 802.3x
- ❑ Direct connection to external Ethernet PHY device through 3.3-volt M11 interface
- ❑ USB full-speed function controller compliant with USB specification 1.1
- ❑ Conformance to USB Communication Device Class Specification
- ❑ 8-bit, 33 MHz UTOPIA level 2 interface compliant with ATM Forum AF-PHY-003
- ❑ Micro wire interface
- ❑ 2-channel, general-purpose timers and 1-channel UART
- ❑ Serial/N-wire interface for field debugging
- ❑ Boundary scan function (JTAG) compliant with IEEE 1149.1
- ❑ 0.25 μm, 3.3-volt I/O operation
- ❑ 2.5-volt core operation
- ❑ 352-pin TBGA package

Figure 1. Internal Block Diagram

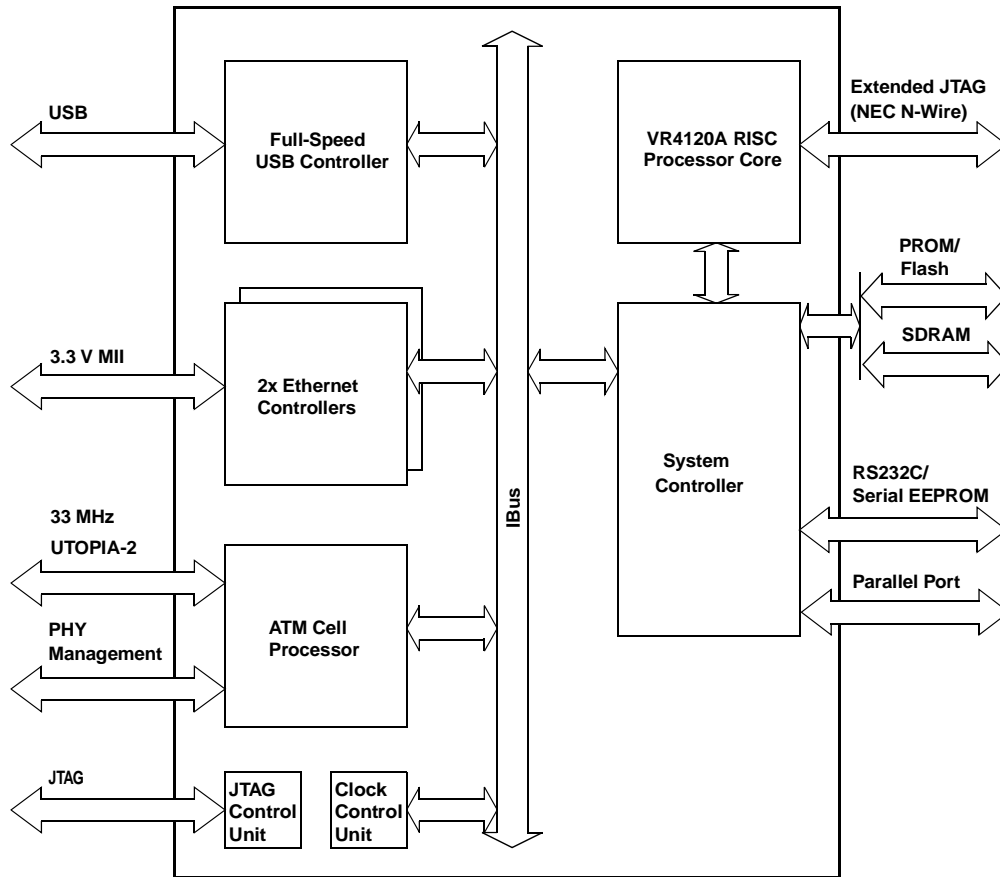
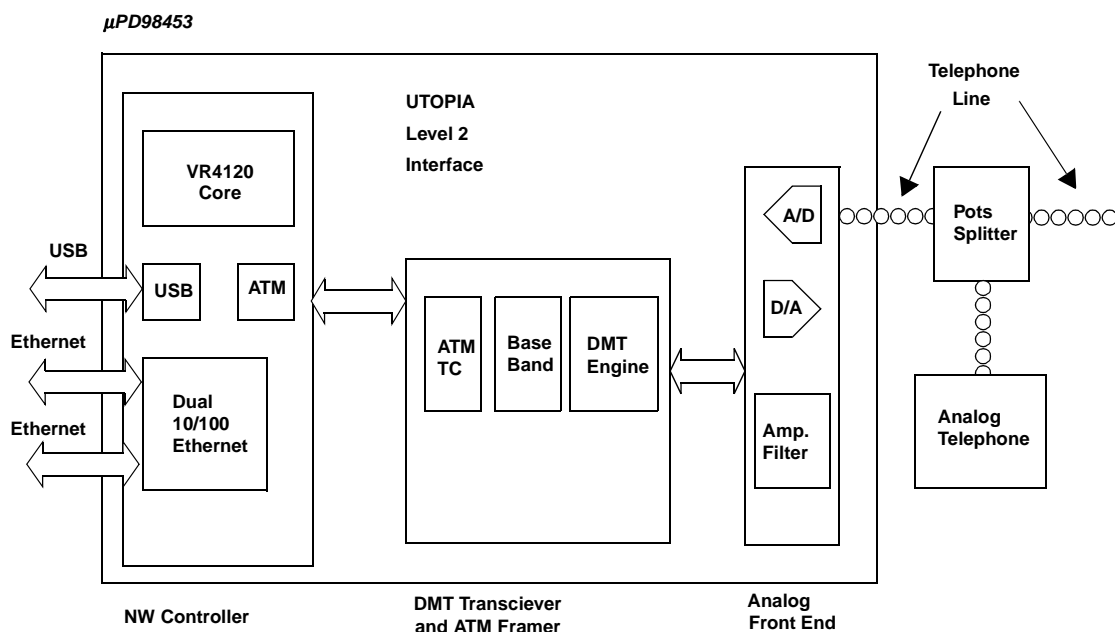

Figure 2. ADSL Chip Set Solution





For literature, call **1-800-366-9782** 7 a.m. to 6 p.m. Pacific time
or FAX your request to **1-800-729-9288**
or visit our web site at **www.necel.com**

The information in this document is current as of June 2000. The information is subject to change without notice. For actual design-in, refer to the latest publications of NEC's data sheets or data books, etc., for the most up-to-date specifications of NEC semiconductor products. Not all products and/or types are available in every country. Please check with an NEC sales representative for availability and additional information. No part of this document may be copied or reproduced in any form or by any means without prior written consent of NEC. NEC assumes no responsibility for any errors that may appear in this document. NEC does not assume any liability for infringement of patents, copyrights or other intellectual property rights of third parties by or arising from the use of NEC semiconductor products listed in this document or any other liability arising from the use of such products. No license, express, implied or otherwise, is granted under any patents, copyrights or other intellectual property rights of NEC or others. Descriptions of circuits, software and other related information in this document are provided for illustrative purposes in semiconductor product operation and application examples. The incorporation of these circuits, software and information in the design of customer's equipment shall be done under the full responsibility of customer. NEC assumes no responsibility for any losses incurred by customers or third parties arising from the use of these circuits, software and information. While NEC endeavours to enhance the quality, reliability and safety of NEC semiconductor products, customers agree and acknowledge that the possibility of defects thereof cannot be eliminated entirely. To minimize risks of damage to property or injury (including death) to persons arising from defects in NEC semiconductor products, customers must incorporate sufficient safety measures in their design, such as redundancy, fire-containment and anti-failure features. NEC semiconductor products are classified into the following three quality grades: "Standard," "Special" and "Specific." The "Specific" quality grade applies only to semiconductor products developed based on a customer-designated quality assurance program for a specific application. The recommended applications of a semiconductor product depend on its quality grade, as indicated below. Customers must check the quality grade of each semiconductor product before using it in a particular application. "Standard": Computers, office equipment, communications equipment, test and measurement equipment, audio and visual equipment, home electronic appliances, machine tools, personal electronic equipment and industrial robots. "Special": Transportation equipment (automobiles, trains, ships, etc.), traffic control systems, anti-disaster systems, anti-crime systems, safety equipment and medical equipment (not specifically designed for life support). "Specific": Aircraft, aerospace equipment, submersible repeaters, nuclear reactor control systems, life support systems and medical equipment for life support, etc. The quality grade of NEC semiconductor products is "Standard" unless otherwise expressly specified in NEC's data sheets or data books, etc. If customers wish to use NEC semiconductor products in applications not intended by NEC, they must contact an NEC sales representative in advance to determine NEC's willingness to support a given application.

(Notes)

- (1) "NEC" as used in this statement means NEC Corporation and also includes its majority-owned subsidiaries.
- (2) "NEC semiconductor products" means any semiconductor product developed or manufactured by or for NEC (as defined above).