

DASH NO.	DESCRIPTION	MADE FROM
----------	-------------	-----------

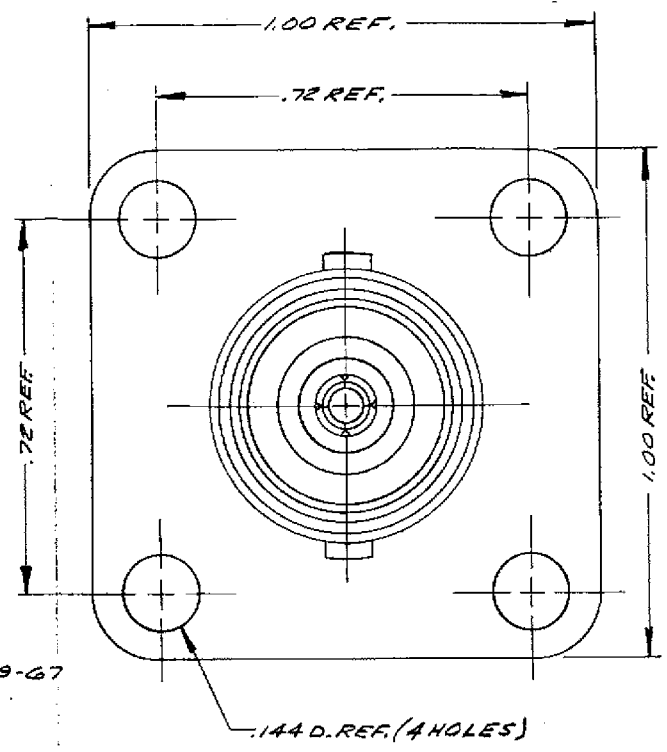
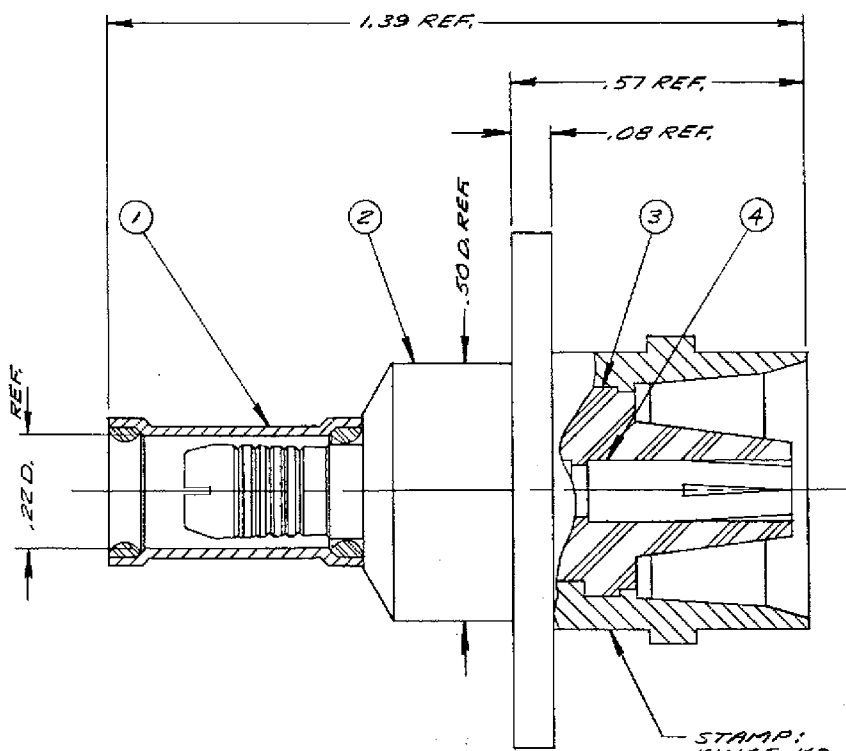

STAMP:
KINGS KD-19-67

- NOTES:
 1. FOR USE WITH RG-142 B, 223 & 400/U CABLE
 2. FOR CABLE TRIMMING USE KTS-160 & KTD 208.
 3. FOR FORMING USE CRIMP DIE SIZE 101.
 4. FOR CABLING INSTRUCTIONS SEE CP-5406.
 5. ITEMS ① & ② TO HAVE TR-5 FINISH.

UNLESS OTHERWISE SPECIFIED:

- | | |
|--|--|
| 1. TOLERANCES: FRACTIONS & 2 PLACE DECIMALS ± .010
3 PLACE DECIMALS ± .004
ANGLES ± 0° 30' | 2. REMOVE ALL BURRS. BREAK SHARP EDGES .005 MAX. |
| 3. NO FILLETS PERMITTED. | 4. SURFACE ROUGHNESS 63 MICROINCHES RMS MAX. |
| T. I. R. CONCENTRICITY OF ANY 2 DIAMETERS MAY NOT EXCEED HALF THE SUM OF THEIR TOLERANCES. | 5. ALL DIMENSIONS PRIOR TO PLATING. |

ITEM	REQ'D	DESCRIPTION	PART NO.
4	1	CAPTIVE CRIMP CONTACT F	1-842-BMA9
3	1	INSULATOR	
2	1	K-GRIP BODY	
1	1	W/P K-GRIP SLEEVE	C-59-218-2-106

REVISIONS	
ISSUE	CHANGES
0	ER 14986 MJB 19 NOV 75
1.	CN 15689A JHP 29 APR 76
2.	CN 16182E GB 9 AUG 76 RG-223 ADDED
3	CN 26163 C EAJ 24 MAY 84
4	CN 29130 C AMD 17 AUG 84

KD-19-67

USED ON:	
REF:	
FINISH	
SPEC.	
MATL.	
SPEC.	
C PANEL JACK	
DRAWN MJB	DATE 21 NOV 75
APPR.	DATE 21 NOV 75

KINGS ELECTRONICS
40 MARBLEDALE ROAD
TUCKAHOE, N. Y. 10707

KD-19-67

S-D