

# DAB L-Band Down-Converter

## Description

The U2755B-B is a monolithic integrated L-band down-converter circuit, fabricated with TEMIC's advanced UHF5S technology. The functionality of this circuit, suitable for applications in a DAB receiver, consists of a gain-controlled amplifier, a gain-controlled mixer, an

output buffer, a gain-control block and an L-band oscillator.

Electrostatic sensitive device.  
Observe precautions for handling.



## Features

- 8.5 V supply voltage
- RF frequency range: 1400 MHz to 1550 MHz
- IF frequency range: 150 MHz to 250 MHz
- Overall IM3 rejection: > 40 dB
- Overall gain-control range: typ. 30 dB
- DSB noise figure: typ. 9.5 dB
- Gain-controlled amplifier

- Gain-controlled L-band mixer
- On-chip gain-control circuitry
- On-chip VCO, typical frequency: 1261.568 MHz
- Balanced oscillator output for PLL
- Internal VCO can be overdriven by an external LO

## Application

Amplifier, mixer and VCO for DAB L-band down-converter

## Block Diagram

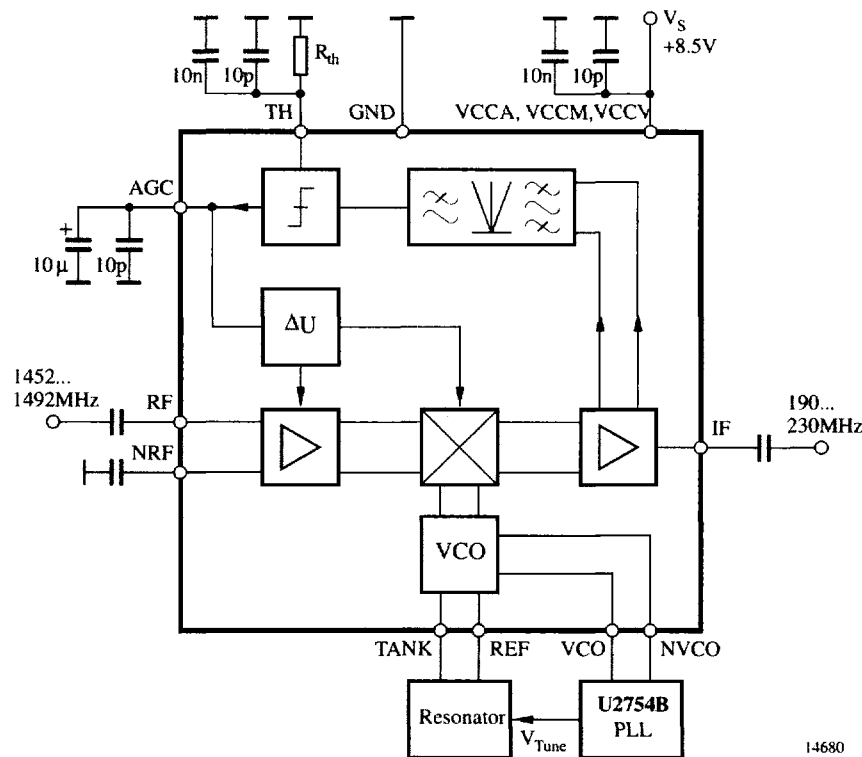

Figure 1. Block diagram

## Ordering Information

Extended Type Number	Package	Remarks
U2755B-BFS	SSO20	

## Pin Description

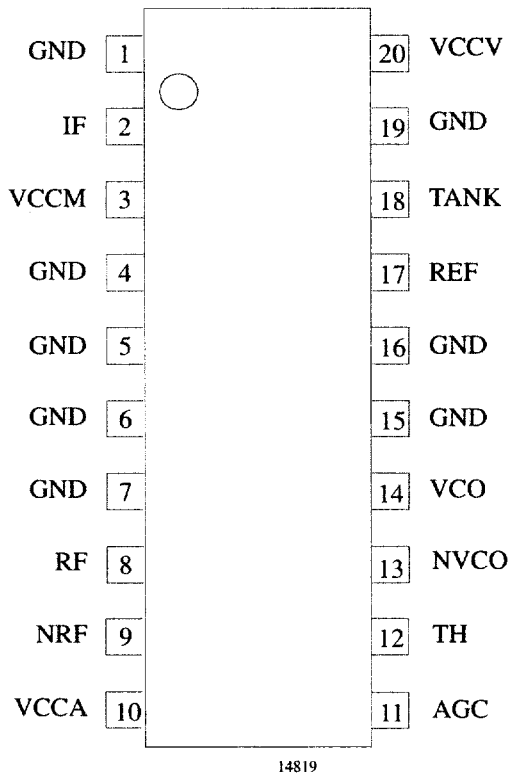

Figure 2. Pinning

Pin	Symbol	Function
1	GND	Ground
2	IF	Intermediate frequency output
3	VCCM	Positive supply voltage for mixer and IF output
4, 5, 6, 7	GND	Ground
8	RF	Radio frequency input
9	NRF	Radio frequency reference input
10	VCCA	Positive supply voltage for amplifier and AGC circuitry
11	AGC	Charge-pump output of comparator, AGC input for amplifier and mixer
12	TH	Threshold input of comparator
13	NVCO	Inverted VCO output for PLL
14	VCO	VCO output for PLL
15, 16	GND	Ground (VCO)
17	REF	Reference pin of VCO
18	TANK	Tank pin of VCO
19	GND	Ground (VCO)
20	VCCV	Positive supply voltage for VCO

## Functional Description

The U2755B-B is an L-band down-converter circuit covering a gain-controlled amplifier, a gain-controlled mixer, an output buffer, a gain-control circuitry and an L-band oscillator. Designed for applications in a DAB receivers, the purpose of this circuit is to down-convert incoming L-band signals in the frequency range between 1452 MHz and 1492 MHz to an IF frequency in the range between about 190 MHz and 230 MHz which can be handled by a subsequent DAB tuner. A block diagram of this circuit is shown in figure 1.

### Gain-Controlled Amplifier

RF signals applied to the input Pin RF are amplified by a gain-controlled amplifier. Although the complementary Pin NRF is internally blocked, it is recommended to block this pin additionally using an external capacitor. The gain-control voltage is generated by internal gain-control circuit. The output signal of this amplifier is fed to a gain-controlled mixer. Figure 12 shows the impedance of the Pin RF in a Smith chart for minimum and maximum gain.

### Gain-Controlled Mixer and Output Buffer

The purpose of this mixer is to down-convert the L-band signal in the frequency range between 1452 MHz and 1492 MHz to an IF frequency in the approximate range 190 MHz to 230 MHz. As in the case of the amplifier, the gain of the mixer is controlled by the gain-control circuit. Before the IF signal is fed to the single-ended output Pin IF it is buffered and filtered by a one-pole lowpass filter at a 3 dB frequency of about 500 MHz. The impedance of the IF port is shown in figure 12.

## Gain-Control Circuitry

The purpose of the gain-control circuitry is to measure the signal power, to compare it with a certain power level and to generate control voltages for the gain-controlled amplifier and mixer, see figure 4.

In order to meet this functionality, the output signal of the buffer amplifier is weakly bandpass filtered (transition range approximate 60 MHz to 550 MHz), rectified, low-pass filtered and fed to a comparator whose threshold can be defined by an external resistor,  $R_{TH}$ , at the Pin TH. By varying the value of this resistor, a power threshold between about  $-35$  dBm and  $-25$  dBm can be selected.

In order to achieve a good intermodulation ratio, it is recommended to keep the power threshold below  $-30$  dBm. An appropriate application is shown in figure 3. Depending on the decision of the comparator, a charge pump charges or discharges a capacitor which is applied to the Pin AGC. By variation of this capacitor, different time constants of the AGC loop can be realized. The voltage arising at the Pin AGC is used to control the setting of the gain of the gain-controlled amplifier and mixer. Figures 7 and 8 show the IF-output power and the gain-control voltage at the Pin AGC as a function of the RF input power for two different values of  $R_{TH}$ .

By applying an external voltage to the Pin AGC, the internal AGC loop can be overdriven. Variations of the

overall gain of this circuit by a change of the gain-control voltage at the Pin AGC cause variations of the total supply current. Figure 10 shows this dependency for two different supply voltages at closed AGC loop.

## Voltage-Controlled Oscillator

A voltage-controlled oscillator supplies an LO signal to the mixer, see figure 5. In the application circuits, figures 3 and 5, a ceramic coaxial resonator is applied to the oscillator's Pins TANK and REF. It should be noted that the Pin REF has to be blocked carefully. Figure 6 shows a different application where the oscillator is overdriven by an external oscillator. In any case a DC path at a low impedance must be established between the Pins TANK and REF. A buffered output signal of the oscillator appearing at the differential output Pins VCO and NVCO is intended to be fed to the frequency synthesizer circuit U2754B which generates a tuning voltage in order to lock the oscillators frequency to a reference frequency.

## Overall Properties

The overall gain of this circuit amounts to 21 dB, the gain-control range is about 30 dB. Figure 11 demonstrates the influence of the supply voltage to the overall gain. The intermodulation properties of this circuit can be taken from figure 9.

## Absolute Maximum Ratings

Parameters	Symbol	Value	Unit
Supply voltage Pins 3, 10 and 20	$V_S$	$-0.3$ to $+9.5$	V
RF input voltage Pin 8	$V_{RF}$	750	mV <sub>pp</sub>
Voltage at Pin AGC Pin 11	$V_{AGC}$	0.5 to 6	V
Voltage at Pin TH Pin 12	$V_{TH}$	$-0.3$ to $+4.0$	V
Input voltage at Pin TANK (internal oscillator overdriven) Pin 18	$V_{TANK}$	1	V <sub>pp</sub>
Current at IF output Pin 2	$I_{IF}$	4.0	mA
Junction temperature	$T_j$	125	°C
Storage temperature	$T_{stg}$	$-40$ to $+125$	°C

## Thermal Resistance

Parameters	Symbol	Value	Unit
Junction ambient SSO20 (mod.)	$R_{thJA}$	65	K/W

## Operating Range

Parameters	Symbol	Value	Unit
Supply voltage Pins 3, 10 and 20	$V_S$	8.0 to 9.35	V
Ambient temperature	$T_{amb}$	$-40$ to $+85$	°C

## Electrical Characteristics

Operating conditions:  $V_S = 8.5\text{ V}$ ,  $T_{amb} = 25^\circ\text{C}$ , application circuit see figure 3, unless otherwise specified

Parameters	Test Conditions / Pins	Symbol	Min.	Typ.	Max.	Unit
<b>Supply current</b>						
Maximum gain	$PRF = -60\text{ dBm}$ , $R_{TH} = 12\text{ k}\Omega$	$I_{S,max}$	35	44	53	mA
Minimum gain	$PRF = -10\text{ dBm}$ , $R_{TH} = 12\text{ k}\Omega$	$I_{S,min}$	41.5	52	62.5	mA
<b>Overall characteristics</b> <span style="float:right">Pin 8 → 2</span>						
Maximum conversion gain	$PRF = -60\text{ dBm}$ , $R_{TH} = 12\text{ k}\Omega$	$g_{c,max}$	18	21	24	dB
Minimum conversion gain	$PRF = -10\text{ dBm}$ , $R_{TH} = 12\text{ k}\Omega$	$g_{c,min}$	-14	-11	-8	dB
AGC range		$\Delta g_c$		32		dB
Third-order 2-tone intermodulation ratio	$R_{TH} = 12\text{ k}\Omega$ $f_{RF1} = 1450\text{ MHz}$ $f_{RF2} = 1451\text{ MHz}$ $PRF1 = PRF2 = -15\text{ dBm}$ $PRF1 = PRF2 = -6\text{ dBm}$	dim3	30	40 20		dB dB
DSB noise figure (50- $\Omega$ system)	Maximum gain	NF		9.5		dB
	Minimum gain			30		dB
<b>RF input</b> <span style="float:right">Pin 8</span>						
Frequency range		$f_{in,RF}$	1400		1550	MHz
Maximum input power	dim3 $\geq 40\text{ dB}$ dim3 $\geq 20\text{ dB}$	$P_{in,max,RF}$		-15 -6		dBm dBm
<b>IF output</b> <span style="float:right">Pin 2</span>						
Frequency range		$f_{out,IF}$	150		250	MHz
Output impedance		$Z_{out,IF}$		50		$\Omega$
Voltage standing wave ratio		VSWR <sub>IF</sub>		2.0		
<b>Gain control</b>						
Threshold adjustment	External resistor Pin 12	$R_{TH}$		12		k $\Omega$
Charge-pump current	$V_{AGC} = 3.25\text{ V}$ $PRF = -10\text{ dBm}$ $PRF = -60\text{ dBm}$	$I_{CP,P}$	90	125	160	$\mu\text{A}$
		$I_{CP,N}$	-90	-125	-160	$\mu\text{A}$
Typical AGC control voltage range	Pin 11	$V_{AGC}$	0.85		5.25	V
<b>VCO</b>						
Frequency		$f_{LO}$	1000	1261.568	1500	MHz
Phase noise	100 kHz dist., see figure 5, Pin 14	$L_{100kHz}$		-100		dBc/Hz
Output power (single ended)	50- $\Omega$ load, VCO overdriven, see figure 6, $P_{LO} = -10\text{ dBm}$ $f_{LO} = 1260\text{ MHz}$	Pin 14 Pin 13	$p_{VCO}$ $p_{NVCO}$	-19 -17	-17 -13	dBm dBm
Minimum input power	VCO overdriven, see figure 6	$P_{LO,min}$		-11		dBm
Maximum input power	VCO overdriven, see figure 6	$P_{LO,max}$		-5		dBm
<b>Isolation</b>						
LO spurious at RF	Pin 8	$P_{LO,RF}$		-64		dBm
LO spurious at IF	Pin 2	$P_{LO,IF}$		-46		dBm
Isolation RF → IF	Pin 8 → 2	$IS_{RF-IF}$		>38		dB

### Application Circuit

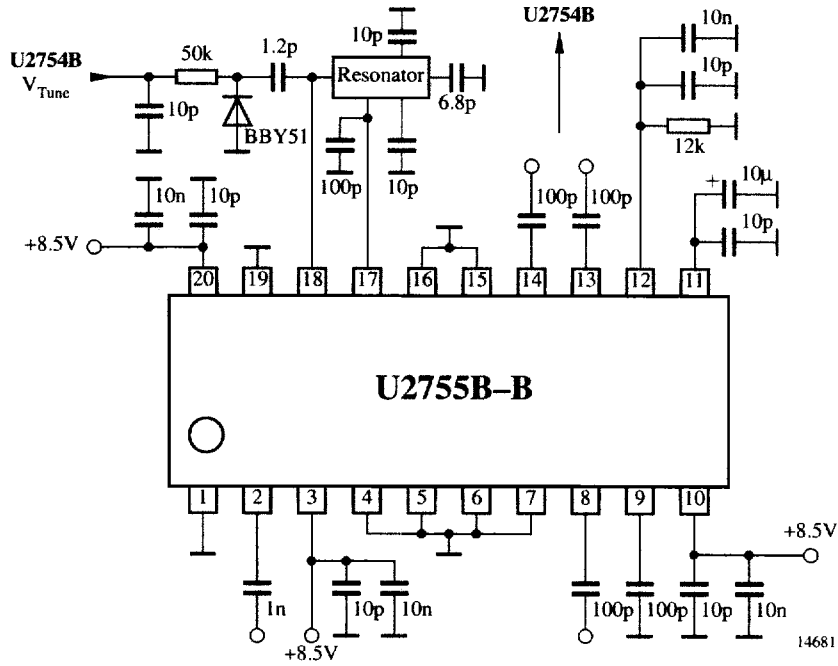

Figure 3. Application circuit

### AGC Control Circuit

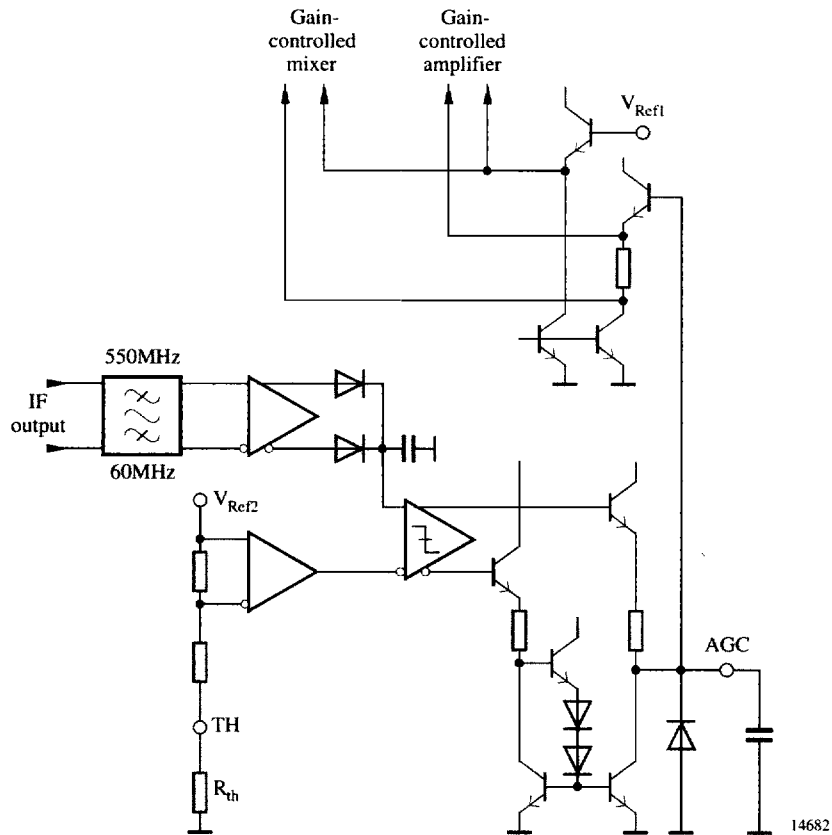

Figure 4. AGC control circuit

### VCO Circuit

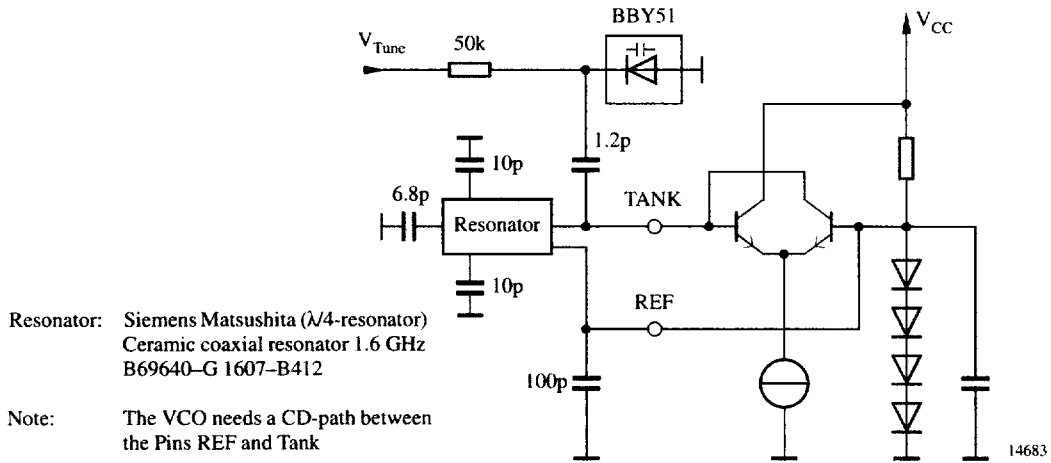

Figure 5. VCO circuit

### Application Circuit for External LO Signal

With an external LO signal, it is possible to overdrive the VCO. In this case, the internal VCO acts as an LO buffer.

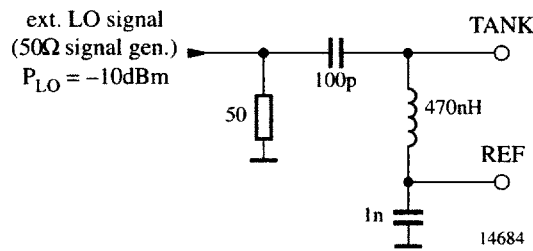

Figure 6. Application circuit for external LO signal

### Gain-Control Characteristics

Operating conditions:

$V_S = 8.5\text{ V}$ ,  $T_{amb} = 25^\circ\text{C}$ ,  $R_{TH} = 12\text{ k}\Omega$  unless otherwise specified, see figure 3, AGC loop closed

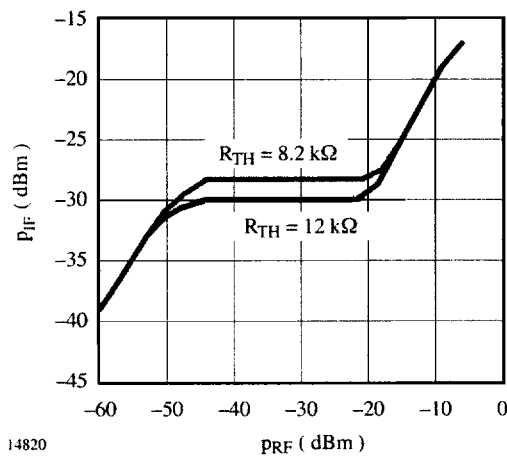

Figure 7. IF output power (Pin 2)

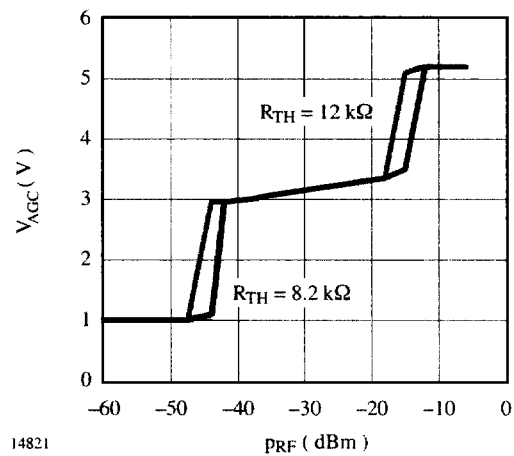
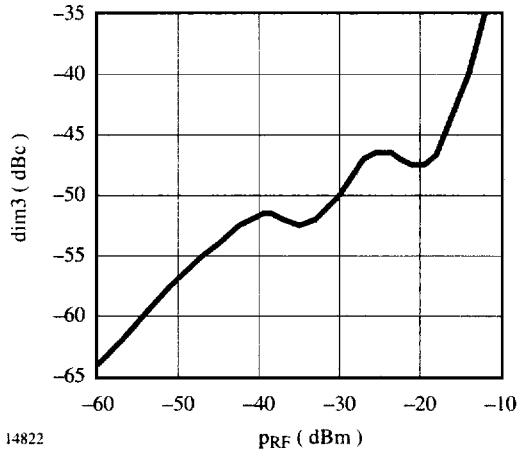

Figure 8. Gain-control voltage (Pin 11)

### Third-Order 2-Tone Intermodulation Ratio (dim3)

Operating conditions:

$V_S = 8.5\text{ V}$ ,  $T_{\text{amb}} = 25^\circ\text{C}$ ,  $R_{\text{TH}} = 12\text{ k}\Omega$ , see figure 3,  $f_{\text{RF1}} = 1490\text{ MHz}$ ,  $f_{\text{RF2}} = 1491\text{ MHz}$ ,  $\text{PRF1} = \text{PRF2} = \text{PRF}$



14822

Figure 9. Third-order 2-tone intermodulation ratio (dim3)

### Conversion Gain vs. Supply Voltage

Operating conditions:

$T_{\text{amb}} = 25^\circ\text{C}$ ,  $R_{\text{TH}} = 12\text{ k}\Omega$ , see figure 3,  $f_{\text{RF}} = 1490\text{ MHz}$ ,  $f_{\text{LO}} = 1262\text{ MHz}$ , AGC loop closed

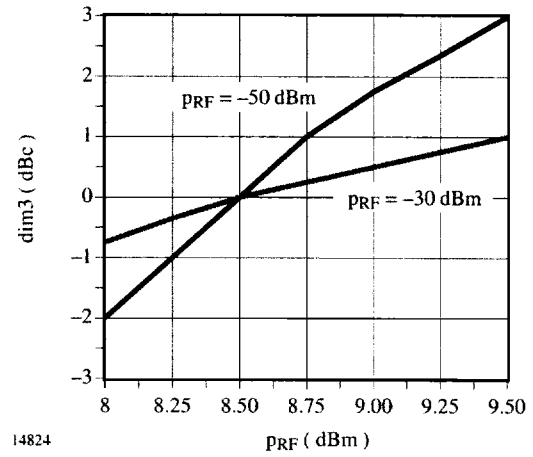

14824

Figure 11. Conversion gain vs. voltage

### Total Supply Current

Operating conditions:

$T_{\text{amb}} = 25^\circ\text{C}$ ,  $R_{\text{TH}} = 12\text{ k}\Omega$ , see figure 3,  $f_{\text{RF}} = 1490\text{ MHz}$ ,  $f_{\text{LO}} = 1262\text{ MHz}$ , AGC loop closed

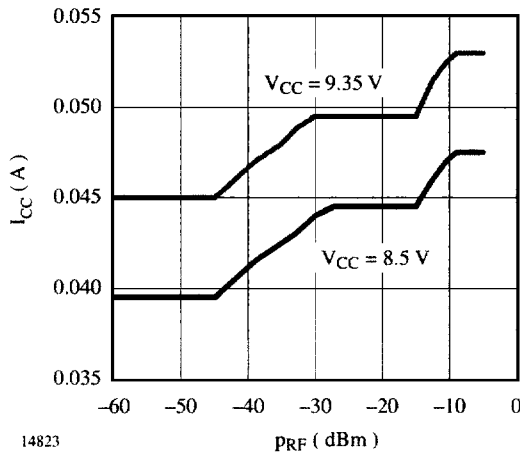

14823

Figure 10. Total supply current

### Port Impedances

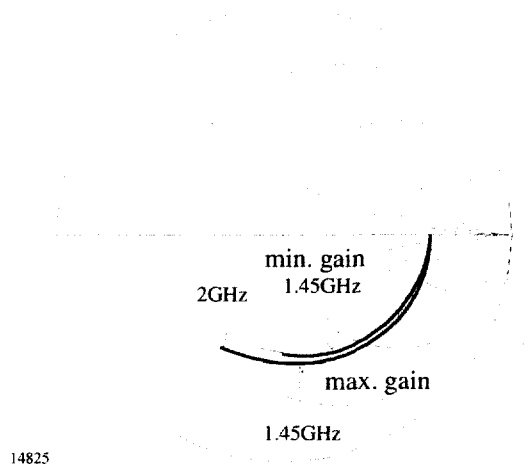

Figure 12.

Min. gain:  $Z(f = 1.45 \text{ GHz}) = 37 \Omega - j 58 \Omega$   
 Max. gain:  $Z(f = 1.45 \text{ GHz}) = 28 \Omega - j 49 \Omega$

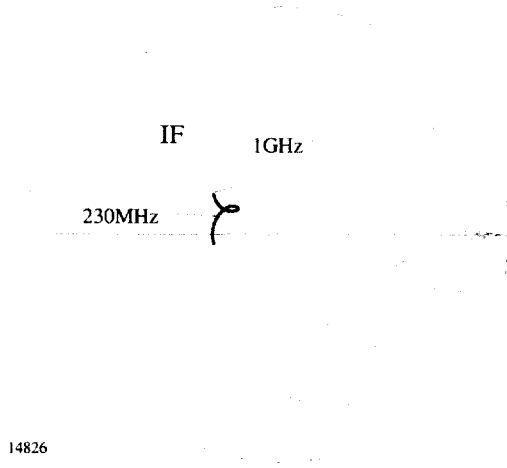
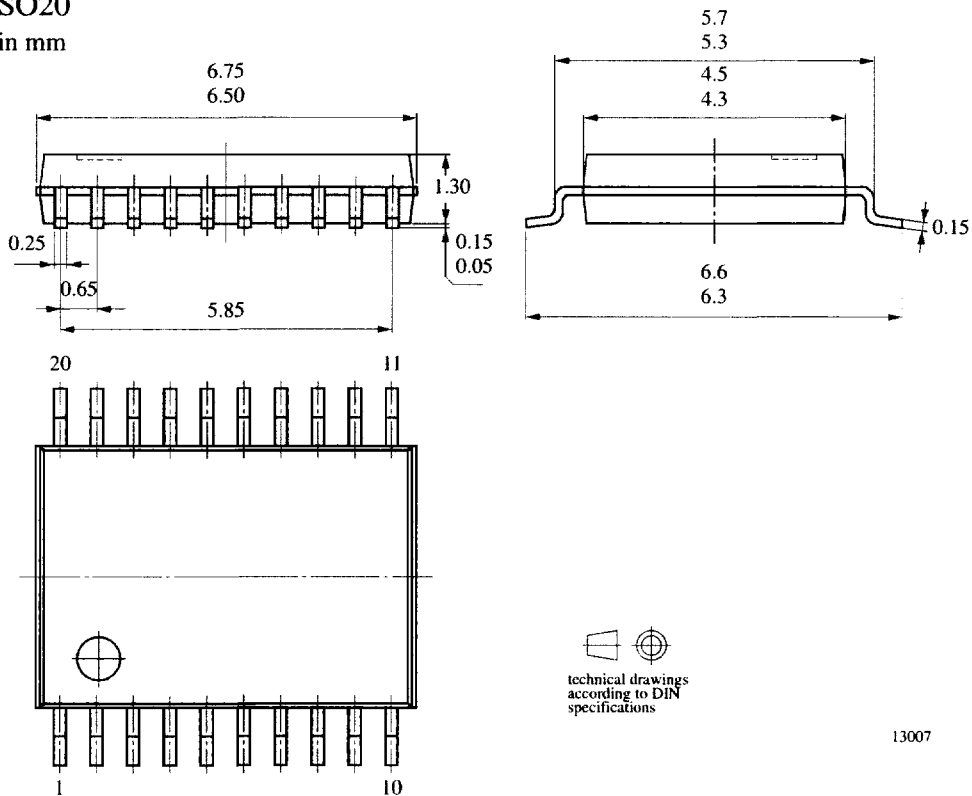

Figure 13.

IF:  $Z(f = 230 \text{ MHz}) = 28 \Omega + j 6 \Omega$

### Package Information

Package SSO20  
 Dimensions in mm



## Ozone Depleting Substances Policy Statement

It is the policy of **TEMIC TELEFUNKEN microelectronic GmbH** to

1. Meet all present and future national and international statutory requirements.
2. Regularly and continuously improve the performance of our products, processes, distribution and operating systems with respect to their impact on the health and safety of our employees and the public, as well as their impact on the environment.

It is particular concern to control or eliminate releases of those substances into the atmosphere which are known as ozone depleting substances (ODSs).

The Montreal Protocol (1987) and its London Amendments (1990) intend to severely restrict the use of ODSs and forbid their use within the next ten years. Various national and international initiatives are pressing for an earlier ban on these substances.

**TEMIC TELEFUNKEN microelectronic GmbH** semiconductor division has been able to use its policy of continuous improvements to eliminate the use of ODSs listed in the following documents.

1. Annex A, B and list of transitional substances of the Montreal Protocol and the London Amendments respectively
2. Class I and II ozone depleting substances in the Clean Air Act Amendments of 1990 by the Environmental Protection Agency (EPA) in the USA
3. Council Decision 88/540/EEC and 91/690/EEC Annex A, B and C (transitional substances) respectively.

**TEMIC** can certify that our semiconductors are not manufactured with ozone depleting substances and do not contain such substances.

**We reserve the right to make changes to improve technical design and may do so without further notice.**

Parameters can vary in different applications. All operating parameters must be validated for each customer application by the customer. Should the buyer use TEMIC products for any unintended or unauthorized application, the buyer shall indemnify TEMIC against all claims, costs, damages, and expenses, arising out of, directly or indirectly, any claim of personal damage, injury or death associated with such unintended or unauthorized use.

TEMIC TELEFUNKEN microelectronic GmbH, P.O.B. 3535, D-74025 Heilbronn, Germany  
Telephone: 49 (0)7131 67 2831, Fax number: 49 (0)7131 67 2423