

TSB12LV01A / TSB12LV01AI ***Data Manual***

IEEE 1394-1995
High-Speed Serial-Bus
Link-Layer Controller

Sourced from: SLLS332A
February 2000



IMPORTANT NOTICE

Texas Instruments and its subsidiaries (TI) reserve the right to make changes to their products or to discontinue any product or service without notice, and advise customers to obtain the latest version of relevant information to verify, before placing orders, that information being relied on is current and complete. All products are sold subject to the terms and conditions of sale supplied at the time of order acknowledgement, including those pertaining to warranty, patent infringement, and limitation of liability.

TI warrants performance of its semiconductor products to the specifications applicable at the time of sale in accordance with TI's standard warranty. Testing and other quality control techniques are utilized to the extent TI deems necessary to support this warranty. Specific testing of all parameters of each device is not necessarily performed, except those mandated by government requirements.

CERTAIN APPLICATIONS USING SEMICONDUCTOR PRODUCTS MAY INVOLVE POTENTIAL RISKS OF DEATH, PERSONAL INJURY, OR SEVERE PROPERTY OR ENVIRONMENTAL DAMAGE ("CRITICAL APPLICATIONS"). TI SEMICONDUCTOR PRODUCTS ARE NOT DESIGNED, AUTHORIZED, OR WARRANTED TO BE SUITABLE FOR USE IN LIFE-SUPPORT DEVICES OR SYSTEMS OR OTHER CRITICAL APPLICATIONS. INCLUSION OF TI PRODUCTS IN SUCH APPLICATIONS IS UNDERSTOOD TO BE FULLY AT THE CUSTOMER'S RISK.

In order to minimize risks associated with the customer's applications, adequate design and operating safeguards must be provided by the customer to minimize inherent or procedural hazards.

TI assumes no liability for applications assistance or customer product design. TI does not warrant or represent that any license, either express or implied, is granted under any patent right, copyright, mask work right, or other intellectual property right of TI covering or relating to any combination, machine, or process in which such semiconductor products or services might be or are used. TI's publication of information regarding any third party's products or services does not constitute TI's approval, warranty or endorsement thereof.

Contents

<i>Section</i>	<i>Title</i>	<i>Page</i>
1	Overview	1-1
1.1	Description	1-1
1.2	Features	1-2
1.2.1	Link	1-2
1.2.2	Physical-Link Interface	1-2
1.2.3	Host Bus Interface	1-2
1.2.4	General	1-2
1.3	Terminal Assignments	1-3
1.4	Terminal Functions	1-4
2	Architecture	2-1
2.1	Functional Block Diagram	2-1
2.1.1	Physical Interface	2-1
2.1.2	Transmitter	2-1
2.1.3	Receiver	2-2
2.1.4	Transmit and Receive FIFOs	2-2
2.1.5	Cycle Timer	2-2
2.1.6	Cycle Monitor	2-3
2.1.7	Cyclic Redundancy Check (CRC)	2-3
2.1.8	Internal Registers	2-3
2.1.9	Host Bus Interface	2-3
3	Internal Registers	3-1
3.1	General	3-1
3.2	Internal Register Definitions	3-1
3.2.1	Version/Revision Register (@00h)	3-3
3.2.2	Node-Address/Transmitter Acknowledge Register (@04h)	3-3
3.2.3	Control Register (@08h)	3-4
3.2.4	Interrupt and Interrupt-Mask Registers (@0Ch, @10h)	3-6
3.2.5	Cycle-Timer Register (@14h)	3-8
3.2.6	Isochronous Receive-Port Number Register (@18h)	3-9
3.2.7	FIFO Control Register (@1Ch)	3-9
3.2.8	Diagnostic Control Register (@20h)	3-10
3.2.9	Phy-Chip Access Register (@24h)	3-10
3.2.10	Asynchronous Transmit-FIFO (ATF) Status Register (@30h)	3-11
3.2.11	ITF Status Register (@34h)	3-12
3.2.12	GRF Status Register (@3Ch)	3-12

3.3	FIFO Access	3-13
3.3.1	General	3-13
3.3.2	ATF Access	3-14
3.3.3	ITF Access	3-15
3.3.4	General-Receive FIFO (GRF)	3-17
3.3.5	RAM Test Mode	3-18
4	TSB12LV01A Data Formats	4-1
4.1	Asynchronous Transmit (Host Bus to TSB12LV01A)	4-1
4.1.1	Quadlet Transmit	4-1
4.1.2	Block Transmit	4-2
4.1.3	Quadlet Receive	4-3
4.1.4	Block Receive	4-4
4.2	Isochronous Transmit (Host Bus to TSB12LV01A)	4-6
4.3	Isochronous Receive (TSB12LV01A to Host Bus)	4-6
4.4	Snoop Receive	4-7
4.5	Phy Configuration Transmit	4-8
4.6	Link-On Transmit	4-9
4.7	Receive Self-ID	4-10
4.8	Received Phy Configuration and Link-On Packet	4-10
5	Electrical Characteristics	5-1
5.1	Absolute Maximum Ratings Over Free-Air Temperature Range	5-1
5.2	Recommended Operating Conditions	5-2
5.3	Electrical Characteristics Over Recommended Ranges of Supply Voltage and Operating Free-Air Temperature	5-2
5.4	Host-Interface Timing Requirements	5-3
5.5	Host-Interface Switching Characteristics Over Operating Free-Air Temperature Range	5-3
5.6	Phy-Interface Timing Requirements Over Operating Free-Air Temperature Range	5-3
5.7	Phy-Interface Switching Characteristics Over Operating Free-Air Temperature Range	5-4
5.8	Miscellaneous Timing Requirements Over Operating Free-Air Temperature Range	5-4
5.9	Miscellaneous Signal Switching Characteristics Over Operating Free-Air Temperature Range	5-4
6	Parameter Measurement Information	6-1

7	TSB12LV01A to 1394 Phy Interface Specification	7-1
7.1	Introduction	7-1
7.2	Assumptions	7-1
7.3	Block Diagram	7-1
7.4	Operational Overview	7-1
	7.4.1 Phy Interface Has Control of the Bus	7-2
	7.4.2 TSB12LV01A Has Control of the Bus	7-2
7.5	Request	7-2
	7.5.1 LREQ Transfer	7-2
	7.5.2 Bus Request	7-4
	7.5.3 Read/Write Requests	7-4
7.6	Status	7-4
	7.6.1 Status Request	7-5
	7.6.2 Transmit	7-5
	7.6.3 Receive	7-6
7.7	TSB12LV01A to Phy Bus Timing	7-6
8	Mechanical Data	8-1

List of Illustrations

<i>Figure</i>	<i>Title</i>	<i>Page</i>
1-1	TSB12LV01A Terminal Functions	1-4
2-1	TSB12LV01A Block Diagram	2-1
3-1	Internal Register Map	3-2
3-2	Interrupt Logic Diagram Example	3-6
3-3	TSB12LV01A Controller-FIFO-Access Address Map	3-13
4-1	Quadlet-Transmit Format	4-1
4-2	Block-Transmit Format	4-2
4-3	Quadlet-Receive Format	4-3
4-4	Block-Receive Format	4-4
4-5	Isochronous-Transmit Format	4-6
4-6	Isochronous-Receive Format	4-6
4-7	Snoop Format	4-7
4-8	Phy Configuration Format	4-8
4-9	Link-On Format	4-9
4-10	Receive Self-ID Format	4-10
6-1	BCLK Waveform	6-1
6-2	Host-Interface Write-Cycle Waveforms (Address: 00h – 2Ch)	6-1
6-3	Host-Interface Read-Cycle Waveforms (Address: 00h – 2Ch)	6-2
6-4	Host-Interface Quick Write-Cycle Waveforms (ADDR0 – ADDR7 . 30h)	6-2
6-5	Host-Interface Quick Read-Cycle Waveforms (ADDR0 – ADDR7 . 30h)	6-3
6-6	Burst Write Waveforms	6-4
6-7	Burst Read Waveforms	6-4
6-8	SCLK Waveform	6-5
6-9	TSB12LV01A-to-Phy-Layer Transfer Waveforms	6-5
6-10	Phy Layer-to-TSB12LV01A Transfer Waveforms	6-6
6-11	TSB12LV01A Link-Request-to-Phy-Layer Waveforms	6-6
6-12	Interrupt Waveform	6-6
6-13	CYCLEIN Waveform	6-7
6-14	CYCLEIN and CYCLEOUT Waveforms	6-7
7-1	Functional Block Diagram of the TSB12LV01A to Phy Layer	7-1
7-2	LREQ Timing	7-6
7-3	Status-Transfer Timing	7-6
7-4	Transmit Timing	7-7
7-5	Receiver Timing	7-7

List of Tables

<i>Table</i>	<i>Title</i>	<i>Page</i>
1-1	Terminal Functions	1-4
3-1	Version/Revision Register Field Descriptions	3-3
3-2	Node-Address/Transmitter Acknowledge Register Field Descriptions	3-3
3-3	Control-Register Field Descriptions	3-4
3-4	Interrupt- and Mask-Register Field Descriptions	3-7
3-5	Cycle-Timer Register Field Descriptions	3-8
3-6	Isochronous Receive-Port Number Register Field Descriptions	3-9
3-7	Node-Address/ Transmitter Acknowledge Register Field Descriptions	3-9
3-8	Diagnostic Control and Status-Register Field Descriptions	3-10
3-9	Phy-Chip Access Register	3-10
3-10	ATF Status Register	3-11
3-11	ITF Status Register	3-12
3-12	GRF Status Register	3-12
3-13	Control Bit Value	3-19
4-1	Quadlet-Transmit Format	4-1
4-2	Block-Transmit Format Functions	4-2
4-3	Quadlet-Receive Format Functions	4-3
4-4	Block-Receive Format Functions	4-5
4-5	Isochronous-Transmit Functions	4-6
4-6	Isochronous-Receive Functions	4-7
4-7	Snoop Functions	4-7
4-8	Phy Configuration Functions	4-8
4-9	Link-On Functions	4-9
4-10	Isochronous-Receive Functions	4-10
7-1	Phy Interface Control of Bus Functions	7-2
7-2	TSB12LV01A Control of Bus Functions	7-2
7-3	Request Functions	7-2
7-4	Bus-Request Functions (Length of Stream: 7 Bits)	7-2
7-5	Read-Register Request Functions (Length of Stream: 9 Bits)	7-3
7-6	Write-Register Request (Length of Stream: 17 Bits)	7-3
7-7	TSB12LV01A Request Functions	7-3
7-8	TSB12LV01A Request-Speed Functions	7-3
7-9	Status-Request Functions (Length of Stream: 16 Bits)	7-5
7-10	Speed Code for Receive	7-6

1 Overview

1.1 Description

The TSB12LV01A is an IEEE 1394-1995 standard (from now on referred to only as 1394) high-speed serial-bus link-layer controller that allows for easy integration into an I/O subsystem. The TSB12LV01A provides a high-performance IEEE 1394-1995 interface with the capability of transferring data between the 32-bit host bus, the 1394 PHY-link interface, and external devices connected to the local bus interface. The 1394 PHY-link interface provides the connection to the 1394 physical (PHY) layer device and is supported by the link-layer controller (LLC). The LLC provides the control for transmitting and receiving 1394 packet data between the FIFO and PHY-link interface at rates of 100Mbit/s, 200Mbit/s, and 400Mbit/s. The TSB12LV01A transmits and receives correctly-formatted 1394 packets and generates and inspects the 32-bit cyclic redundancy check (CRC). The TSB12LV01A is capable of being cycle master and supports reception of isochronous data on two channels or all isochronous channels. TSB12LV01A has a generic 32-bit host bus interface, which connects to most 32-bit hosts. The LLC also provides the capability to receive status from the physical layer device and to access the physical layer control and status registers by the application software. An internal 2K-byte memory can be configured as multiple variable-size FIFOs and eliminates the need for external FIFOs. Separate FIFOs can be user-configured to support general 1394 receive, asynchronous transmit, and isochronous transmit transfer operations. These functions are accomplished by appropriately sizing the general receive FIFO (GRF), asynchronous transmit FIFO (ATF), and isochronous transmit FIFO (ITF).

The TSB12LV01A provides bus holding buffers on the PHY interface for simple and cost effective single-capacitor isolation.

The TSB12LV01A is a revision of the TSB12C01A, with feature enhancements and corrections. All errata items to the TSB12C01A have been corrected, and the following feature enhancements have been made:

- Cycle start packets can be stored in the GRF.
- Isochronous and asynchronous packet transmit and receive can be enabled/disabled independently. Asynchronous transmit is disabled upon reset, while isochronous transmit and receive is unaffected.
- One, two, or all isochronous channels can be received.
- When receiving packets, RxData can be programmed to interrupt the host processor on programmable block boundaries, so the host can retrieve data from the GRF when each block is available.

This is especially useful if the GRF is smaller than the expected receive packet size. RxData can also be programmed to interrupt the host processor when each packet is received.

- Host bus burst mode data transfer is supported, at the peak rate of one quadlet (four bytes) per BCik cycle for ATF write, ITF write, and GRF read.
- A FIFO status read can be accomplished in three BCik cycles: 1. Address cycle 2. Data cycle 3. Idle cycle
- Several changes in the register map have been made to improve host bus data throughput and reduce status read and interrupt overhead. ATF status (30h), ITF status (34h) and GRF status (3Ch) contains only status information. FIFO control (1Ch) is defined to control ATF size, ITF size, clear FIFO function, and block size for GRF received packet. ATF status register and ITF status register will report flags: full, empty and available space for host bus burst write. GRF status register will report flags: empty, total stored data count, and next received block size.

- Maximum data burst throughput on the host bus interface is 200 Mbyte/s, if Bclk is run at 50 MHz.
- Received packet formats now include the packet error status in the first quadlet of the packet in the receive FIFO.
- Provides bus-hold buffers on physical interface for low-cost single capacitor isolation

This document is not intended to serve as a tutorial on 1394; users are referred to the IEEE 1394-1995 serial bus standard for detailed information regarding the 1394 high-speed serial bus.

1.2 Features

The following are features of the TSB12LV01A.

1.2.1 Link

- Supports Provision of IEEE 1394-1995 (1394) Standard for High-Performance Serial Bus
- Transmits and Receives Correctly Formatted 1394 Packets
- Supports Isochronous Data Transfer
- Performs Function of 1394 Cycle Master
- Generates and Checks 32-Bit CRC
- Detects Lost Cycle-Start Messages
- Contains Asynchronous, Isochronous, and General-Receive FIFOs Totaling 2K Bytes

1.2.2 Physical-Link Interface

- Interfaces Directly to the TSB11LV01, TSB14C01, TSB21LV03A, and TSB41LV0x PHY Chips
- Supports Speeds of 100 Mbits/s, 200 Mbits/s, and 400 Mbits/s
- Implements the Physical-Link Interface Described in Annex J of the IEEE 1394-1995 Standard
- Supports TI Bus Holder Isolation External Implementation

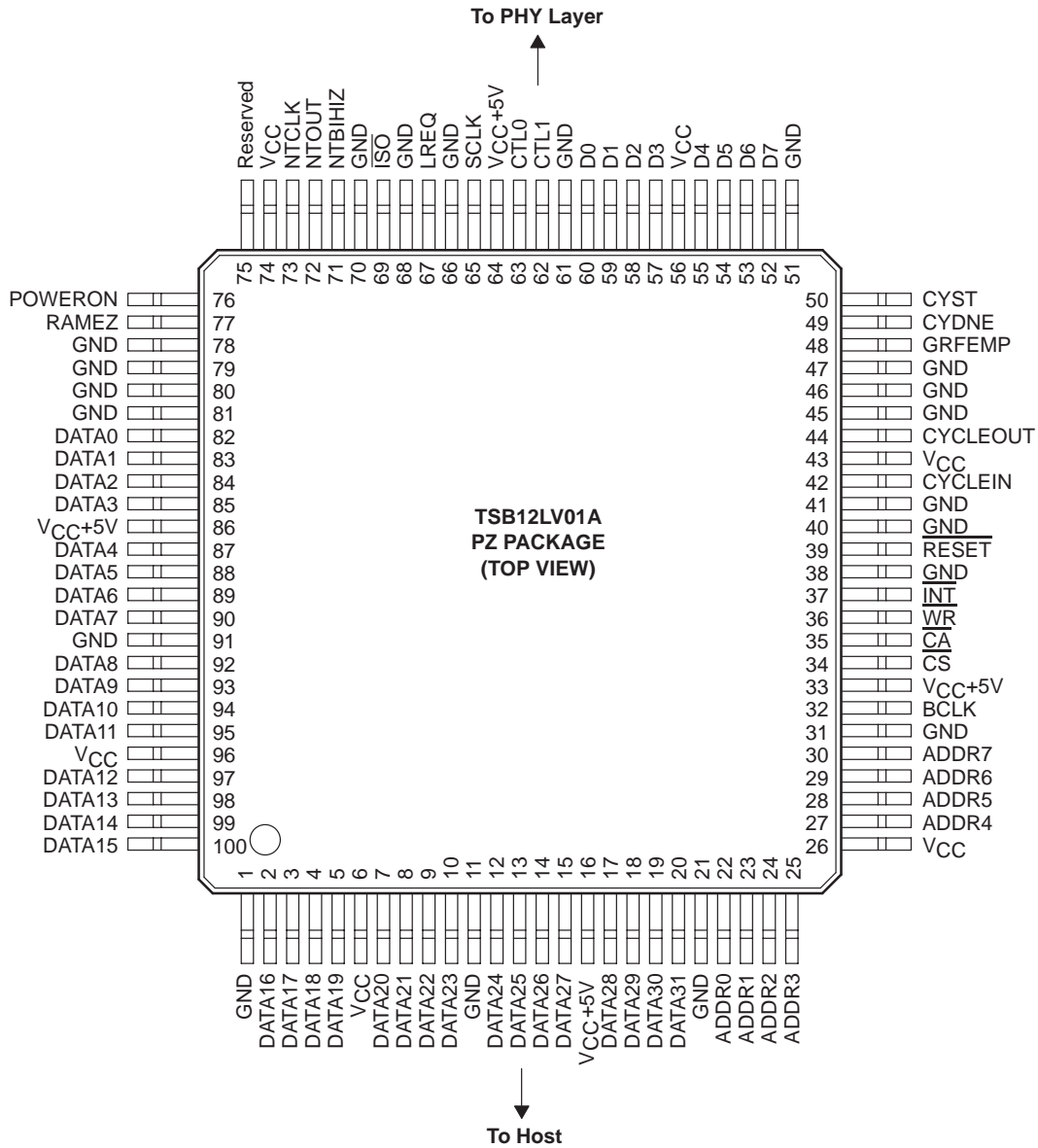
1.2.3 Host Bus Interface

- Provides Chip Control With Directly Addressable Registers
- Is Interrupt Driven to Minimize Host Polling
- Has a Generic 32-Bit Host Bus Interface

1.2.4 General

- Operates from a 3.3-V Power Supply While Maintaining 5-V Tolerant Inputs
- Manufactured with Low-Power CMOS Technology
- Packaged in a 100-Pin Thin Quad Flat Package (TQFP) (PZ Package) for 0°C to 70°C and –40°C to 85°C Operation

1.3 Terminal Assignments



- NOTES: A. Tie reserved terminals to GND.
 B. Bit 0 is the most significant bit (MSB).

1.4 Terminal Functions

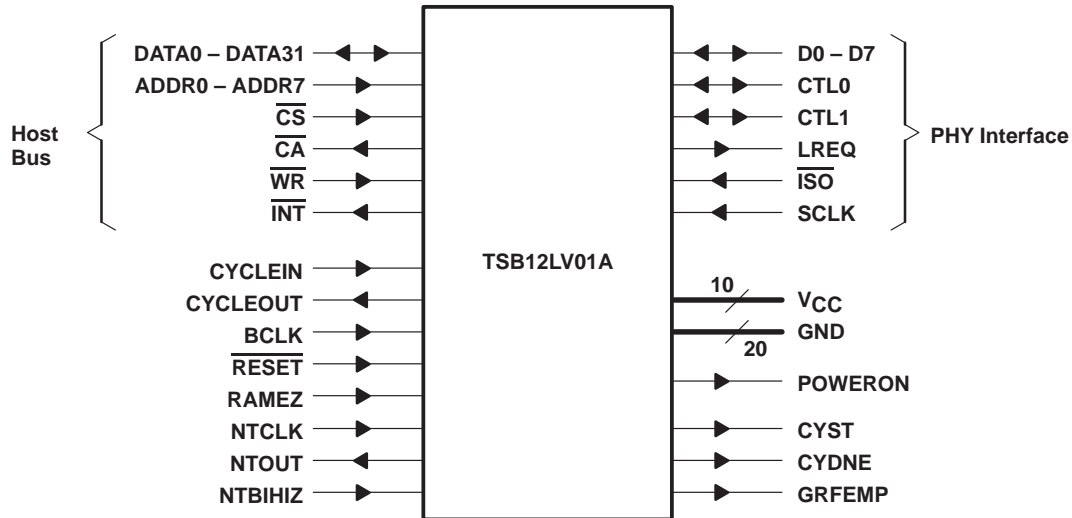


Figure 1–1. TSB12LV01A Terminal Functions

Table 1–1. Terminal Functions

TERMINAL NAME	NO.	I/O	DESCRIPTION
Host Bus Interface			
ADDR0 – ADDR7	22–25 27–30	I	Address 0 through address 7. Host bus address bus bits 0 through 7 that address the quadlet-aligned FIFOs and configuration registers. The two least significant address lines, 6 and 7, must be grounded. Bit 0 is the most significant bit.
$\overline{\text{CA}}$	35	O	Cycle acknowledge (active low). $\overline{\text{CA}}$ is a TSB12LV01A control signal to the host bus. When asserted (low), access to the configuration registers or FIFO is complete.
$\overline{\text{CS}}$	34	I	Cycle start (active low). $\overline{\text{CS}}$ is a host bus control signal to initiate access to the configuration registers or FIFO.
DATA0 – DATA31	2–5 7–10 12–15 17–20 82–85 87–90 92–95 97–100	I/O	Data 0 through 31. DATA is a host bus data bus bits 0 through 31. Bit 0 is the most significant bit. Byte 0 is the most significant byte.
$\overline{\text{INT}}$	37	O	Interrupt (active low). When $\overline{\text{INT}}$ is asserted (low), the TSB12LV01A notifies the host bus that an interrupt has occurred. $\overline{\text{INT}}$ is cleared when all the bits INT bits are cleared in the INT register (or the mask is set false).
$\overline{\text{WR}}$	36	I	Read/write enable. When $\overline{\text{WR}}$ is deasserted (high) in conjunction with $\overline{\text{CS}}$, a read from the TSB12LV01A is requested. When $\overline{\text{WR}}$ is asserted (low) in conjunction with $\overline{\text{CS}}$, a write to the TSB12LV01A is requested.

Table 1–1. Terminal Functions (Continued)

TERMINAL NAME	NO.	I/O	DESCRIPTION
PHY Interface			
CTL1, CTL0	62, 63	I/O	Control 1 and control 0 of the PHY-link control bus. CTL1 and CTL0 indicate the four operations that can occur in this interface (see Section 7 of this document or Annex J of the IEEE 1394-1995 standard for more information about the four operations). These terminals have bus holder functionality built in. When $\overline{\text{RESET}}$ is asserted, CTL0 and CTL1 are initialized to 0 (low) for one SCLK cycle and then released. The bus holders then hold CTL0 and CTL1 at 0 (low) until a transition is driven.
D0 – D7	52–55 57–60	I/O	Data 0 through data 7 of the PHY-link data bus. Data is expected on D0 – D1 for 100 Mb/s packets, D0 – D3 for 200 Mb/s, and D0 – D7 for 400 Mb/s transfers. These terminals have bus holder functionality built in. When $\overline{\text{RESET}}$ is asserted, D0 – D7 are initialized to 0 (low) for one SCLK cycle and then released. The bus holders then hold D0 – D7 at 0 (low) until a transition is driven.
$\overline{\text{ISO}}$	69	I	Isolation barrier (active low). $\overline{\text{ISO}}$ is asserted (low) when an isolation barrier is present. This terminal only supports bus holder type isolation.
LREQ	67	O	Link request. LREQ is a TSB12LV01A output that makes bus requests and access requests to the PHY layer. On the first rising edge of SCLK when $\overline{\text{RESET}}$ is asserted, LREQ is driven to 0 (low).
POWERON	76	O	Power on indicator to PHY interface. When active, POWERON has a clock output with 1/16 of the BCLK frequency and indicates to the PHY interface that the TSB12LV01A is powered. This terminal can be connected to the link power status (LPS) terminal on the TI PHY devices to provide an indication of the LLC power condition. When $\overline{\text{RESET}}$ is asserted, POWERON is driven to 0 (low).
SCLK	65	I	System clock. SCLK is a 49.152-MHz clock from the PHY, that generates the internal 24.576-MHz clock used internally in the TSB12LV01A.
Miscellaneous Signals			
BCLK	32	I	Bus clock. BCLK is the host bus clock used for the host-interface module of the TSB12LV01A. It is asynchronous to SCLK.
CYCLEIN	42	I	Cycle in. CYCLEIN is an optional external 8,000-Hz clock used to time the isochronous cycle clock, and it should only be used when attached to the cycle-master node. It is enabled by the cycle source bit and should be tied high when not used.
CYCLEOUT	44	O	Cycle out. CYCLEOUT is the version of the isochronous cycle clock used by the TSB12LV01A. It is based on the internal timer controls and received cycle-start messages.
CYDNE	49	O	Status of CyDne bit. CYDNE indicates the value of the CyDne bit of the interrupt register. This terminal is asserted for as long as the interrupt bit is assigned.
CYST	50	O	Status of CySt bit. CYST indicates the value of the CySt bit of the interrupt register. This terminal is asserted for as long as the interrupt bit is set.

Table 1–1. Terminal Functions (Continued)

TERMINAL NAME	NO.	I/O	DESCRIPTION
GND	1, 11, 21, 31, 38, 40, 41, 45–47, 51, 61, 66, 68, 70, 78–81, 91		Ground reference
GRFEMP	48	O	Status of Empty bit. This terminal is asserted for as long as the GRFEMP bit is set.
RAMEZ	77	I	RAM 3-state enable. When RAMEZ is deasserted (low), FIFOs are enabled. When RAMEZ is asserted, the FIFOs are 3-state outputs. (This is a manufacturing test-mode condition and should be grounded under normal operating conditions.)
NTBIHIZ	71	I	NAND-tree bidirectional 3-state output. When NTBIHIZ is deasserted (low), the bidirectional I/Os operate in a normal state. When NTBIHIZ is asserted (high), the bidirectional I/Os are in the 3-state output mode. (This is a manufacturing test-mode condition and should be grounded under normal operating conditions.)
NTCLK	73	I	NAND clock input. The NAND-tree clock is used for V_{IH} and V_{IL} manufacturing tests. (This input should be grounded under normal operating conditions.)
NTOUT	72	O	NAND-tree output. This output should remain open under normal operating conditions.
$\overline{\text{RESET}}$	39	I	Reset (active low). $\overline{\text{RESET}}$ is the asynchronous reset to the TSB12LV01A.
VCC	6, 26, 43, 56, 74, 96		3.3-V $\pm 5\%$ power supplies
VCC+5V	16, 33 64, 86		5-V $\pm 5\%$ power supplies

2 Architecture

2.1 Functional Block Diagram

The functional block architecture of the TSB12LV01A is shown in Figure 2–1.

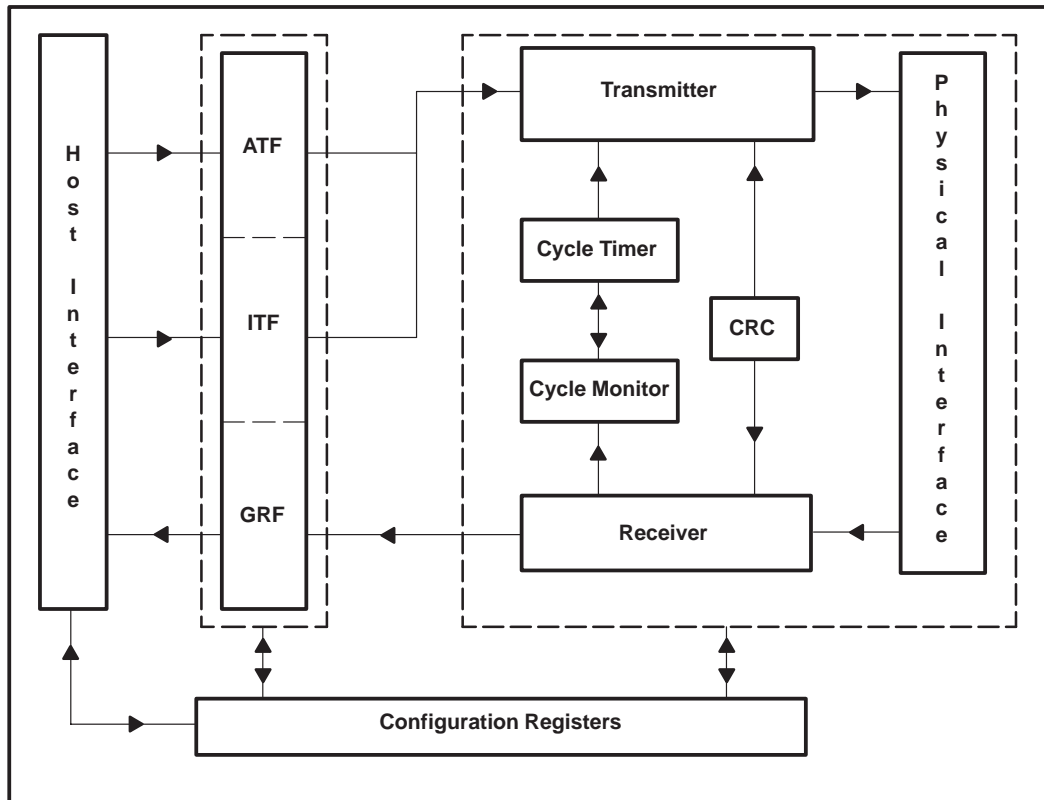


Figure 2–1. TSB12LV01A Block Diagram

2.1.1 Physical Interface

The physical (PHY) interface provides PHY-level services to the transmitter and receiver. This includes gaining access to the serial bus, sending packets, receiving packets, sending and receiving acknowledge packets, and reading and writing PHY registers.

The PHY interface module also interfaces to the PHY chip and conforms to the PHY-link interface specification described in Annex J of the IEEE 1394-1995 standard (refer to Section 7 of this document for more information).

2.1.2 Transmitter

The transmitter retrieves data from either the ATF or the ITF and creates correctly formatted serial-bus packets to be transmitted through the PHY interface. When data is present at the ATF interface to the transmitter, the TSB12LV01A PHY interface requests the serial bus and upon receiving a grant, sends a packet. When data is present at the ITF interface to the transmitter, the TSB12LV01A arbitrates for the serial bus during the next isochronous cycle. The transmitter autonomously sends the cycle-start packets when the chip is the cycle master. The PHY interface provides PHY-level services to the transmitter and receiver. This includes gaining access to the serial bus, sending packets, receiving packets, and receiving status from the physical layer.

2.1.3 Receiver

The receiver takes incoming data from the PHY interface and determines if the incoming data is addressed to this node. If the incoming packet is addressed to this node, the CRC of the packet header is checked. If the header CRC is good, the header is stored in the GRF. For block and isochronous packets, the remainder of the packet is stored one quadlet at a time. The receiver places a status quadlet in the GRF after the last quadlet of the packet is checked in the GRF. The status quadlet contains the error code for the packet. The error code is the acknowledge code that was or could have been sent for that packet. For broadcast packets that do not need an acknowledge packet, the error code is the acknowledge code that would have been sent. This acknowledge code tells the transaction layer whether or not the data CRC is good or bad. When the header CRC is bad, the header is flushed and the rest of the packet is ignored. Bad packets are automatically flushed by the receiver.

When a cycle-start message is received, it is detected and the cycle-start message data is sent to the cycle timer. The cycle-start messages can be placed in the GRF like other quadlet packets.

2.1.4 Transmit and Receive FIFOs

The TSB12LV01A contains two transmit FIFOs (ATF and ITF) and one receive FIFO (GRF). Each of these FIFOs is one quadlet wide and their length is software selectable. These software-selectable FIFOs allow customization of the size of each FIFO for individual applications. The sum of all FIFOs cannot be larger than 512 quadlets. The transmit FIFOs are write only from the host bus interface, and the receive FIFO is read only from the host bus interface. FIFO sizes must not be changed on the fly. All transactions must be ignored and FIFOs cleared before changing the FIFO sizes.

An example of how to use software-adjustable FIFOs follows:

In applications where isochronous packets are large and asynchronous packets are small, the implementers can set the ITF to a large size, 200 quadlets, and set the ATF to a smaller size, 100 quadlets. This means 212 quadlets are allocated to the GRF. Notice that the sum of all FIFOs is equal to 512 quadlets. Only the ATF size and the ITF size can be programmed, the remaining space is assigned to the GRF.

2.1.5 Cycle Timer

The cycle timer is used by nodes that support isochronous data transfer. The cycle timer is a 32-bit cycle-timer register. Each node with isochronous data-transfer capability has a cycle-timer register as defined in the IEEE 1394-1995 standard. In the TSB12LV01A, the cycle-timer register is implemented in the cycle timer and is located in IEEE-1212 initial register space at location 200h. It can also be accessed through the host bus at address 14h. The cycle timer contains the cycle-timer register. The cycle-timer register consists of three fields; cycle offset, cycle-count, and seconds count. The low-order 12 bits of the timer are a modulo 3072 counter, which increments once every 24.576-MHz clock periods (or 40.69 ns). The next 13 higher-order bits are a count of 8,000-Hz (or 125 μ s) cycles, and the highest 7 bits count seconds. The timer can be disabled using the cycle-timer-enable bit in the control register.

The cycle timer has two possible sources. The first cycle-source option is when the cycle source (CySrc) bit in the configuration register is set, then the CYCLEIN input causes the cycle-count field to increment for each positive transition of the CYCLEIN input (8 kHz) and the cycle offset resets to all zeros. CYCLEIN should only be the source when the node is cycle master. When the cycle-count field increments, CYCLEOUT is generated.

The second cycle-source option is when the CySrc bit is cleared. In this state, the cycle-offset field of the cycle-timer register is incremented by the internal 24.576-MHz clock. The cycle timer is updated by the reception of the cycle-start packet for the noncycle master nodes. Each time the cycle-offset field rolls over, the cycle-count field is incremented and the CYCLEOUT signal is generated. The cycle-offset field in the cycle-start packet is used by the cycle-master node to keep all nodes in phase and running with a nominal isochronous cycle of 125 μ s.

The CTCLEOUT signal indicates whenever the cycle-count field of the cycle timer register increments. Therefore, for a cyclemaster node CYCLEOUT indicates that it is time to send a cycle-start packet. And, on noncyclemaster nodes, CYCLEOUT indicates that it is time to expect a cycle-start packet. The cycle-start interrupt bit is set when the cycle-start packet is sent from the cyclemaster node or received by a noncyclemaster node.

2.1.6 Cycle Monitor

The cycle monitor is only used by nodes that support isochronous data transfer. The cycle monitor observes chip activity and handles scheduling of isochronous activity. When a cycle-start message is received or sent, the cycle monitor sets the cycle-started interrupt bit. It also detects missing cycle-start packets and sets the cycle-lost interrupt bit when this occurs. When the isochronous cycle is complete, the cycle monitor sets the cycle-done-interrupt bit. The cycle monitor instructs the transmitter to send a cycle-start message when the cycle-master bit is set in the control register.

2.1.7 Cyclic Redundancy Check (CRC)

The CRC module generates a 32-bit CRC for error detection. This is done for both the header and data. The CRC module generates the header and data CRC for transmitting packets and checks the header and data CRC for received packets. See the IEEE 1394-1995 standard for details on the generation of the CRC.

NOTE:This is the same CRC used by the IEEE802 LANs and the X3T9.5 FDDI.

2.1.8 Internal Registers

The internal registers control the operation of the TSB12LV01A.

2.1.9 Host Bus Interface

The host bus interface allows the TSB12LV01A to be easily connected to most host processors. This host bus interface consists of a 32-bit data bus and an 8-bit address bus. The TSB12LV01A utilizes cycle-start and cycle-acknowledge handshake signals to allow the local bus clock and the 1394 clock to be asynchronous to one another. The TSB12LV01A is interrupt driven to reduce polling.

3 Internal Registers

3.1 General

The host-bus processor directs the operation of the TSB12LV01A through a set of registers internal to the TSB12LV01A itself. These registers are read or written by asserting CS with the proper address on ADDR0 – ADDR7 and asserting or deasserting WR depending on whether a read or write is needed. Figure 3–1 lists the register addresses; subsequent sections describe the function of the various registers.

3.2 Internal Register Definitions

The TSB12LV01A internal registers control the operation of the TSB12LV01A. The bit definitions of the internal registers are shown in Figure 3–1 and are described in subsections 3.2.1 through 3.2.12.

There are three modes to access the internal TSB12LV01A registers; normal mode, quick mode, and burst mode. The registers from address 00h to 2Ch are accessed using normal mode as shown in Figures 6–2 and 6–3.

The registers 30h, 34h, 3Ch, and C0h may be accessed using quick mode reads as shown in Figure 6–5.

The registers 30h and 80h through 9Ch may be accessed using quick mode writes as shown in Figure 6–4.

NOTE:

The protocols for normal mode and quick mode are exactly the same. The only difference being that quick mode simply returns CA quicker.

The registers 84h, 8Ch, 94h, 9Ch, A0h, and B0h may be accessed using burst mode writes as shown in Figure 6–6.

The register C0h may be accessed using burst mode reads as shown in Figure 6–7.

	0	1	2	3	4	5	6	7	8	9	10	11	12	13	14	15	16	17	18	19	20	21	22	23	24	25	26	27	28	29	30	31	3031-3042	
00h	Version																Revision										Version							
04h	Bus Number								Node Number							Root	ATAck							AckV	Node Address									
08h	IdVal	RxSlid	BsyCtrl	RAI	RcvCyst	TxAEn	RxAEn	TxEh	RxEh	AckCen	RstTx	RstRx										CyMas	CySrc	CyTEh	TrgEn	IRP1En	IRP2En					FhBad	Control	
0Ch	Int	PhInt	PhRRx	PhRst	SIDCom	TxRdy	RxDia	RxAEn	CmdRst	ACKRCV			ITBadF	ATBadF		SntRj	HdrEr	TCErr				CyTm0	CySec	CySt	CyDne	CyPnd	CyLst	CArbFI			ArbGp	FrGp	IArbFI	Interrupt
10h	Int	PhInt	PhRRx	PhRst	SIDCom	TxRdy	RxDia	RxAEn	CmdRst	ACKRCV			ITBadF	ATBadF		SntRj	HdrEr	TCErr				CyTm0	CySec	CySt	CyDne	CyPnd	CyLst	CArbFI			ArbGp	FrGp	IArbFI	Interrupt Mask
14h	7 Bits				Rollover @ 8000							13 Bits			Rollover @ 3072						12 Bits			Cycle Timer										
	Seconds Count				Cycle Count							Cycle Offset																						
18h	TAG1		IR Port1				TAG2		IR Port2														MonTag	Isoch Port Number										
1Ch	CLrATF	CirITF	CirGRF		Trigger Size				ATFSize				ITFSize							FIFO Control														
20h	ENSp			regRW																											Diagnostics			
24h	RdPhy	WrPhy		PhyRgAd				PhyRgData								PhyRxAd		PhyRxData							Phy Chip Access									
28h																																Reserved		
2Ch																																Reserved		
30h	Full	Empty	ConErr	AdrCir	Control	RAMTest	AdrCounter														ATFSpaceCount			ATF Status (R/W)										
34h	Full	Empty																													ITFSpaceCount			ITF Status (Read Only)
38h																																Reserved		
3Ch	Empty	cd	PacCom	GRFTotalCnt							GRFSize							WriteCount										GRF Status (Read Only)						
40h																																Reserved		

NOTE A: All gray areas (bits) are reserved bits.

Figure 3–1. Internal Register Map

3.2.1 Version/Revision Register (@00h)

The version/revision register allows software to be written that supports multiple versions of the high-speed serial-bus link-layer controllers. This register is at address 00h and is read only. The initial value is 3031_3042h.

Table 3–1. Version/Revision Register Field Descriptions

BITS	ACRONYM	FUNCTION NAME	DESCRIPTION
0–15	Version	Version	Version of the TSB12LV01A
16–31	Revision	Revision	Revision of the TSB12LV01A

3.2.2 Node-Address/Transmitter Acknowledge Register (@04h)

The node-address/transmitter acknowledge register controls which packets are accepted/rejected, and it presents the last acknowledge received for packets sent from the ATF. This register is at offset 04h. The bus number and node number fields are read/write. The AT acknowledge (ATAck) received is normally read only. Setting the regRW bit in the diagnostic register makes these fields read/write. The initial value is FFFF_0000h. The node number field and the root field are automatically updated by every PHY register 0 status transfer to the TSB12LV01A.

Table 3–2. Node-Address/Transmitter Acknowledge Register Field Descriptions

BITS	ACRONYM	FUNCTION NAME	DESCRIPTION
0–9	BusNumber	Bus number	BusNumber is the 10-bit IEEE 1212 bus number that the TSB12LV01A uses with the node number in the SOURCE address for outgoing packets and to accept or reject incoming packets. The TSB12LV01A always accepts packets with a bus number equal to 3FFh.
10–15	NodeNumber	Node number	NodeNumber is the 6-bit node number that the TSB12LV01A uses with the bus number in the source address for outgoing packets and to accept or reject incoming packets. The TSB12LV01A always accepts packets with the node address equal to 3Fh. After bus reset, the node number is automatically set to the node's Physical_ID by a PHY register 0 transfer.
16 [†]	Root	Root	If Root =1 this node is root, read only
17–22 [‡]	Reserved	Reserved	Reserved
23–27 [‡]	ATAck	Address transmitter acknowledge received	ATAck is the last acknowledge received by the transmitting node in response to a packet sent from the asynchronous transmit-FIFO. ATAck=0_XXXX the low order 4 bits present normal ack code receive from the receiving node. ATAck=1_0000 an acknowledge timeout occurred ATAck=1_0011 ack packet error (ack parity error, or ack pPending too long or ack pending too short)
28–30	Reserved	Reserved	Reserved

[†] This bit is new to the TSB12LV01A and does not exist in the TSB12C01A.

[‡] The bit number of these bits is different than the bit number listed for the TSB12C01A.

Table 3–2. Node-Address/Transmitter Acknowledge Register Field Descriptions (Continued)

BITS	ACRONYM	FUNCTION NAME	DESCRIPTION
31†	AckV	Acknowledge valid	Whenever an ack packet is received, AckValid is set to 1. After the node-address/transmitter acknowledge register is read, AckValid is automatically reset to 0. This bit is also used to indicate arbitration failure. If a non-broadcast asynchronous packet is in the ATF ready to transmit and a TxRdy interrupt occurs, and AckValid is 0, this indicates no ack packet was received and no ack time-out occurred. The packet is still in the ATF and the TSB12LV01A automatically arbitrates for the bus again. Under normal conditions AckValid=0 means ATAck contains last received ack code information.

† This bit is new to the TSB12LV01A and does not exist in the TSB12C01A.

3.2.3 Control Register (@08h)

The control register dictates the basic operation of the TSB12LV01A. This register is at address 08h and is read/write. The initial value is 0000_0000h.

Table 3–3. Control-Register Field Descriptions

BITS	ACRONYM	FUNCTION NAME	DESCRIPTION
0	IdVal	ID valid	When IdVal is set, the TSB12LV01A accepts packets addressed to the IEEE 1212 address set (Node Number) in the node-address register. When IdVal is cleared, the TSB12LV01A accepts only broadcast packets.
1	RxSId	Received self-ID packets	When RxSId is set, the self-identification packets generated by phy chips during bus initialization are received and placed into the GRF as a single packet. Each self-identification packet is composed of two quadlets, where the second quadlet is the logical inverse of the first. If ACK (4 bits) equals 1h, then the data is good. If ACK equals Dh, then the data is wrong. When the RxSId is set to 1, it also receives and places Link-on-packet and PHY Configuration packet into the GRF. For Link-on-packet and PHY Configuration packet only the first quadlet of each packet is stored in the GRF.
2	BsyCtrl	Busy control	When this bit is set, this node sends an ack_busy_x acknowledge in response to all received non-broadcast asynchronous packets. When this bit is clear, this node sends ack_busy_x acknowledge only if the GRF is full.
3†	RAI	Received all isochronous packets	If RAI = 1, RxIE = 1, TSB12LV01A receives all Isochronous packets and stores in the GRF.
4†	RcvCySt	Receive cycle start	If RcvCySt = 1, it stores the received cycle start packet in the GRF.
5	TxAEn	Transmitter enable	When TxAEn is cleared, the transmitter does not arbitrate or send asynchronous packets. After bus reset, TxAEn is cleared since the node number may have changed.
6	RxAEn	Receiver enable	When RxAEn is cleared, the receiver does not receive any asynchronous packets. After bus reset, RxAEn is cleared since the node number may have changed.
7†	TxIE	Transmit isochronous enable	When TxIE is cleared, the transmitter does not arbitrate to send isochronous packets

† This bit is new to the TSB12LV01A and does not exist in the TSB12C01A.

Table 3–3. Control-Register Field Descriptions (Continued)

BITS	ACRONYM	FUNCTION NAME	DESCRIPTION
8†	RxIEn	Receive isochronous enable	When RxIEn is cleared, the receiver does not receive isochronous packets.
9†	AckCEn	Ack complete enable	When AckCEn is set, the 12LV01A sends the Ack_complete code to the transmit node for receiving a non-broadcast write request packet if GRF is not full and there is no error in the packet. When AckCEn is cleared, TSB12LV01A sends an Ack_pending code for the above condition.
10	RstTx	Reset transmitter	When RstTx is set, the entire transmitter resets synchronously. This bit clears itself.
11	RstRx	Reset receiver	When RstRx is set, the entire receiver resets synchronously. This bit clears itself.
12–19†	Reserved	Reserved	Reserved
20	CyMas	Cycle master	When CyMas is set and the TSB12LV01A is attached to the root phy, the cyclemaster function is enabled. When the cycle_count field of the cycle timer register increments, the transmitter sends a cycle-start packet. This bit is not cleared upon bus reset. When another node is selected as root during a bus reset, the transaction layer in the now nonroot TSB12LV01A node must clear this bit and the transaction layer in the TSB12LV01A node selected as root must set this bit.
21	CySrc	Cycle source	When CySrc is set, the cycle_count field increments and the cycle_offset field resets for each positive transition of CYCLEIN. When CySrc is cleared, the cycle_count field increments when the cycle_offset field rolls over.
22	CyTEn	Cycle-timer enable	When CyTEn is set, the cycle_offset field increments. This bit must be set to transmit cycle start packets for cycle master node. This bit must be set to receive or transmit isochronous packets.
23	TrgEn	Trigger size function enable	If TrgEn is set, the receiver partitions the received packet into trigger size blocks. Trigger size is defined in FIFO Control register. For example: if trigger size=8 and total received packet size (excluding header CRC and data CRC)=20 quadlets. The receiver creates 3 blocks of data in GRF. Each block starts with a packet token quadlet to indicate how many quadlets follow this packet token. The first and the second block have 9 quadlets (including the packet token quadlet). The third block has 5 quadlets(including a packet token quadlet). Each block triggers one RxDta interrupt. The purpose of the trigger size function is to allow the receiver to receive a packet larger than GRF size and host bus can read the received data when each block is available without waiting till the whole packet is loaded into GRF, so the host bus latency is reduced.
24	IRP1En	IR port 1 enable	When IRP1En is set, the receiver accepts isochronous packets when the channel number matches the value in the IR Port1 field.
25	IRP2En	IR port 2 enable	When IRP2En is set, the receiver accepts isochronous packets when the channel number matches the value in the IR Port2 field.
26–30	Reserved	Reserved	Reserved
31†	FhBad	Flush bad packets	When the FhBad is set, the receiver flushes any received bad packets (including a partial packet due to GRF full)and it does not generate a RxDta interrupt. When FhBad is set, it disables the TrgEn function.

† This bit or bits are new to the TSB12LV01A and do not exist in the TSB12C01A.

3.2.4 Interrupt and Interrupt-Mask Registers (@0Ch, @10h)

The interrupt and interrupt-mask registers work in tandem to inform the host bus interface when the state of the TSB12LV01A changes. The interrupt register is at address 0Ch. The interrupt mask register is at address 10h. The interrupt mask register is read/write. Its initial value is 0000_0000h. When regRW is cleared to 0, the interrupt register (except for the Int bit) is cleared. When regRW (in diagnostics register @20h) is set to 1, the interrupt register (including the Int bit) is read/write. Its initial value is 1000_0000h.

The interrupt bits all work the same. For example, when a phy interrupt occurs, the PhInt bit is set. If the PhIntMask bit is set, the Int bit is set. If the IntMask is set, the INT signal is asserted. The logic for the interrupt bits is shown in Figure 3–2. Table 3–4 defines the interrupt and interrupt-mask register field descriptions. As shown in Figure 3–2, the INT bit is the OR of interrupt bits 1 – 31. When all the interrupt bits are cleared, INT equals 0. When any of the interrupt bits are set, INT is set to 1, even if the INT bit was just cleared.

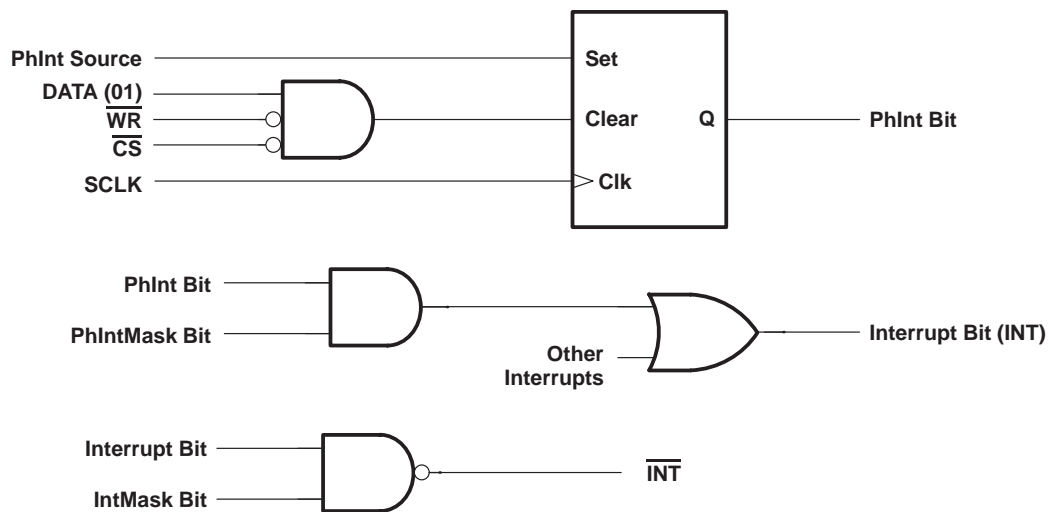


Figure 3–2. Interrupt Logic Diagram Example

Table 3–4. Interrupt- and Mask-Register Field Descriptions

BITS	ACRONYM	FUNCTION NAME	DESCRIPTION
0	Int	Interrupt	Int contains the value of all interrupt and interrupt mask bits ORed together.
1	PhInt	Phy chip interrupt	When PhInt is set, the phy chip has signaled an interrupt through the pPhy interface.
2	PhyRRx	Phy register information received	When PhyRRx is set, a register value has been transferred to the phy chip access register (offset 24h) from the phy interface.
3	PhRst	Phy reset started	When PhRst is set, a phy-layer reconfiguration has started (1394 bus reset).
4†	SIDComp	Self ID complete	When SIDComp is set, a complete bus reset process is finished. If the RxSid bit (bit 1) of the control register (08h) is set, the GRF contains all received self-ID packets.
5	TxRdy	Transmitter ready	When TxRdy is set, the transmitter is idle and ready. When TxRdy is set to 1 and AckV (bit 31 of node address register) remains 0 for a non-broadcast asynchronous packet, the transmitter fails arbitration and arbitrates for the bus again when the bus is idle.
6	RxDta	Receiver has data	In normal mode and when set, RxDta indicates that the receiver has accepted a block of data(if TrgEn=0, a block of data means a packet) into the GRF interface. However, during the self-ID portion of a bus reset, this bit is set after the bus reset process is done.
7	CmdRst	Command reset received	When CmdRst is set, the receiver has been sent a quadlet write request addressed to the RESET_START CSR register.
8	ACKRCV	Receive ACK Packet Interrupt	This interrupt is triggered when an acknowledge is received or a timeout has occurred after an asynchronous packet is sent. To enable this register, the mask interrupt should be set to 1.
9–10	Reserved	Reserved	Reserved
11†	ITBadF	Bad pPacket formatted in ITF	When ITBadF is set, the transmitter has detected invalid data at the isochronous transmit-FIFO interface.
12†	ATBadF	Bad packet formatted in ATF	When ATBadF is set, the transmitter has detected invalid data at the asynchronous transmit-FIFO interface. If the first quadlet of a packet is not written to the ATF_First or ATF_First & Update, the transmitter enters a state denoted by an ATBadF interrupt. An underflow of the ATF also causes an ATBadF interrupt. If this state is entered, no asynchronous packets can be sent until the ATF is cleared by way of the CLR ATF control bit. Isochronous packets can be sent while in this state.
13	Reserved	Reserved	Reserved
14	SntRj	Busy acknowledge sent by receiver	SntRj is set when there is a GRF overflow. The receiver is then forced to send a busy acknowledge to a packet addressed to this node because the GRF overflowed.
15	HdrEr	Header error	When HdrEr is set, the receiver detected a header CRC error on an incoming packet that may have been addressed to this node. The packet will be discarded.
16	TCErr	Transaction code error	When TCErr is set, the transmitter detected an invalid transaction code in the data at the transmit FIFO interface.
17–18	Reserved	Reserved	Reserved
19†	CyTmOut	Cycle timer out	Isochronous cycle lasts more than 125 μ s.

† This bit is new to the TSB12LV01A and does not exist in the TSB12C01A.

Table 3–4. Interrupt- and Mask-Register Field Descriptions (Continued)

BITS	ACRONYM	FUNCTION NAME	DESCRIPTION
20	CySec	Cycle second incremented	When CySec is set, the cycle-second field in the cycle-timer register is incremented. This occurs approximately every second when the cycle timer is enabled.
21	CySt	Cycle started	When CySt is set, the transmitter has sent or the receiver has received a cycle-start packet.
22	CyDne	Cycle done	When CyDne is set, a subaction gap has been detected on the bus after the transmission or reception of a cycle-start packet. This indicates that the isochronous cycle is over.
23	CyPnd	Cycle pending	When CyPnd is set, the cycle-timer offset is set to 0 (rolled over or reset) and remains set until the isochronous cycle ends.
24	CyLst	Cycle lost	When CyLst is set, the cycle timer has rolled over twice without the reception of a cycle-start packet. This occurs only when this node is not the cycle master.
25	CArbFI	Cycle arbitration failed	When CArbFI is set, the arbitration to send the cycle-start packet failed.
26–28	Reserved	Reserved	Reserved
29†	ArbGp	Arbitration gap	Arbitration gap occurred.
30†	FrGp	Subaction gap	Subaction gap occurred.
31	IArbFI	Isochronous arbitration failed	When IArbFI is set, the arbitration to send an isochronous packet failed.

† This bit is new to the TSB12LV01A and does not exist in the TSB12C01A.

3.2.5 Cycle-Timer Register (@14h)

The cycle-timer register contains the seconds_count, cycle_count and cycle_offset fields of the cycle timer. The register is at address 14h and is read/write. This field is controlled by the cycle master, cycle source, and cycle timer enable bits of the control register. Its initial value is 0000_0000h.

Table 3–5. Cycle-Timer Register Field Descriptions

BITS	ACRONYM	FUNCTION NAME	DESCRIPTION
0–6	seconds_count	Seconds count	1-Hz cycle-timer counter
7–19	cycle_count	Cycle count	8,000-Hz cycle-timer counter
20–31	cycle_offset	Cycle offset	24.576-MHz cycle-timer counter

3.2.6 Isochronous Receive-Port Number Register (@18h)

The isochronous receive-port number register controls which isochronous channels are received by this node. If RAI of Control register is set, this register value is don't care since all channels are received. This register is at address 18h. The register is read/write, and its initial value is 0000_0000h.

Table 3–6. Isochronous Receive-Port Number Register Field Descriptions

BITS	ACRONYM	FUNCTION NAME	DESCRIPTION
0–1†	TAG1	Tag bit 1	Isochronous data format tag. See IEEE 1394-1995 6.2.3 and IEC 61883.
2–7	IRPort1	Isochronous receive TAG bits and port 1 channel number	IRPort1 contains the channel number of the isochronous packets the receiver accepts when IRP1En is set. See Table 4–5 and Table 4–6 for more information.
8–9†	Tag2	Tag bit 2	Isochronous data format tag. See IEEE 1394-1995 6.2.3
10–15	IRPort2	Isochronous receive TAG bits and port 2 channel number	IRPort2 contains the channel number of the isochronous packets the receiver accepts when IRP2En is set (bits 8 and 9 are reserved as TAG bits). See Table 4–5 and Table 4–6 for more information.
16–30	Reserved	Reserved	Reserved
31†	Mon Tag	Tag enable	When set, it enables the tag bit comparison. If both Tagx and IR-PORTx match for port number x, the matching receive Iso packet is stored in the GRF.

† This bit or bits are new to the TSB12LV01A and do not exist in the TSB12C01A.

3.2.7 FIFO Control Register (@1Ch)‡

FIFO Control register is used to clear ATF, ITF, GRF and set up the trigger size for the trigger-size function. ATF size and ITF size are all in the quadlet. GRF size = 512–(ATF Size)– (ITF size)

Table 3–7. Node-Address/ Transmitter Acknowledge Register Field Descriptions

BITS	ACRONYM	FUNCTION NAME	DESCRIPTION
0	ClrATF	Clear asynchronous transfer FIFO	Writing 1 to this bit automatically clears the ATF to 0. This bit is self clearing.
1	ClrITF	Clear isochronous transfer FIFO	Writing 1 to this bit automatically clears the ITF to 0. This bit is self clearing.
2	ClrGRF	Clear general receive FIFO	Writing 1 to this bit automatically clears the GRF to 0. This bit is self clearing.
3–4	Reserved	Reserved	Reserved
5–13	Trigger Size	Trigger size	Trigger size is used to split a big receive packet into several smaller blocks of data, so the host bus does not have to wait the whole packet cycle before it can read the GRF, When TrgEn=0 or FhBad=1 in the control register, trigger size is don't care. The trigger size is specified in quadlets.
14–22	ATFSize	Asynchronous transmitter FIFO size	ATFSize allocates ATF size in the quadlets. The limitations for ATFSize are ATFSize<=512 and (ATFSize+ITFSize) <=512.
23–31	ITFSize	Isochronous transmitter FIFO size	Same as above except for ITF

‡ This register is new to the TSB12LV01A and does not exist in the TSB12C01A.

3.2.8 Diagnostic Control Register (@20h)

The diagnostic control and status register allows for the monitoring and control of the diagnostic features of the TSB12LV01A. The register is at address 20h. The regRW and enable snoop bits are read/write. When regRW is cleared, all other bits are read only. When regRW is set, all bits are read/write. Its initial value is 0000_0000h.

Table 3–8. Diagnostic Control and Status-Register Field Descriptions

BITS	ACRONYM	FUNCTION NAME	DESCRIPTION
0	ENSp	Enable snoop	When ENSp is set, the receiver accepts all packets on the bus regardless of address or format. The receiver uses the snoop data format defined in Section 4.4.
1–3†	Reserved	Reserved	Reserved
4	regR/W	Register read/write access	When regR/W is set, most registers are fully read/write.
5–31†	Reserved	Reserved	Reserved

† This bit or bits are new to the TSB12LV01A and do not exist in the TSB12C01A.

3.2.9 Phy-Chip Access Register (@24h)

The phy-chip access register allows access to the registers in the attached phy chip. The most significant 16 bits send read and write requests to the phy-chip registers. The least significant 16 bits are for the phy chip to respond to a read request sent by the TSB12LV01A. The phy-chip access register also allows the phy interface to send important information back to the TSB12LV01A. When the phy interface sends new information to the TSB12LV01A, the phy register-information-receive (PhyRRx) interrupt is set. The register is at address 24h and is read/write. Its initial value is 0000_0000h. All gap counts (set in the phy device registers) on all nodes of a 1394 bus must be identical. This can be accomplished by using the phy configuration packets to set a specific gap count or by using two bus resets, which resets the gap counts to the default 3Fh. See Section 4.6 for the format of the phy configuration packets.

Table 3–9. Phy-Chip Access Register

BITS	ACRONYM	FUNCTION NAME	DESCRIPTION
0	RdPhy	Read phy-chip register	When RdPhy is set, the TSB12LV01A sends a read register request with address equal to phyRgAd to the phy interface. This bit is cleared when the request is sent.
1	WrPhy	Write phy-chip register	When WrPhy is set, the TSB12LV01A sends a write register request with an address equal to phyRgAd on to the phy interface. This bit is cleared when the request is sent.
2–3	Reserved	Reserved	Reserved
4–7	PhyRgAd	Phy-chip-register address	PhyRgAd is the address of the phy-chip register that is to be accessed.
8–15	PhyRgData	Phy-chip-register data	PhyRgData is the data to be written to the phy-chip register indicated in PhyRgAd.
16–19	Reserved	Reserved	Reserved
20–23	PhyRxAd	Phy-chip-register-received address	PhyRxAd is the address of the register from which PhyRxData came.
24–31	PhyRxData	Phy-chip-register-received data	PhyRxData contains the data from register addressed by PhyRxAd.

3.2.10 Asynchronous Transmit-FIFO (ATF) Status Register (@30h)

The ATF status register allows access to the registers that control or monitor the ATF. The register is at address 30h. All the FIFO flag bits are read only, and the FIFO control bits are read/write. Its initial value is 0000_0000h. This register provides RAM test mode control and status signals.

Table 3–10. ATF Status Register

BITS	ACRONYM	FUNCTION NAME	DESCRIPTION
0	Full	ATF full flag	When Full is set, the FIFO is full. Write operations are ignored.
1†	Empty	ATF–empty flag	When Empty is set, the FIFO is empty.
2†	ConErr	Control bit error	Each location in the FIFO contains 33-bit data, the MSB is called the Control bit, which is used to indicate the first quadlet of each packet for ATF and ITF. In the GRF the control bit is used to indicate whether the low order 32 bits contain a packet token. If control bit is 1, it indicates that the low order bits at that location are the first quadlet of the packet in ATF or ITF, or a packet token in GRF. During RAM test mode, the entire FIFO becomes a RAM. Control bits can be verified indirectly. If ConErr is 1, read value of control bit does not match write value, which is defined by control (bit 4 of ATF status register). ConErr is clear to 0 by writing 1 to AdrClr or 0 to RAM test.
3†	AdrClr	Adder clear control	Set AdrClr to 1 to clear AdrCounter and ConErr to 0, during the next RAM access. The RAM test mode accesses location 0. AdrClr clears itself to 0.
4†	Control	Control bit	The value of control bit is used to relate the MSB of access RAM location in RAM test mode. For RAM test mode WRITE– control bit value concatenated with DATA0 – DATA31, writes to the location pointed by the AdrCounter. For RAM test mode READ– the read location is pointed to by the current AdrCounter. The read Control counter bit is compared with Control bit (bit 4) of ATF status register, if it does not match, it sets ConErr to 1.
5†	RAMTest	Ram test mode	When RAM test is set to 1, all FIFO function are disabled. Write to or read from address 80h writes to or reads from the location pointed to by AdrCounter. After each write or read, AdrCounter is incremented by 1. AdrCounter address range is from 0 to 511. For normal FIFO operation , clear RAMTest to 0, and AdrClr, control, AdrCounter are don't care.
6–14†	AdrCounter	Address counter	Gives the address location
15–22†	Reserved	Reserved	Reserved
23–31†	ATFSpace-Count	ATF space count in quadlets	ATF available space for loading next packet into ATF. If ATFSpace-Count is larger than the next packet, then the software can burst write the next packet into ATF. It only requires two host bus transactions: One ATF Status read and one burst write to ATF

† This bit or bits are new to the TSB12LV01A and do not exist in the TSB12C01A.

3.2.11 ITF Status Register (@34h)

The ITF status register allows access to the registers that control or monitor the ITF. The register is at address 34h. All the FIFO flag bits are read only, and the FIFO control bits are read/write. Its initial value is 0000_0000h.

Table 3–11. ITF Status Register

BITS	ACRONYM	FUNCTION NAME	DESCRIPTION
0	Full	ITF full flag	When Full is set, the FIFO is full and all writes are ignored.
1†	Empty	Empty	When Empty is set, ITF is empty.
2–22†	Reserved	Reserved	Reserved
23–31†	ITFSpace Count	ITF space count in quadlets	ITF available space for loading the next packet to the ITF. If ITFSpaceCount is larger than the next packet quadlet, then the software can burst write the next packet into ITF. It only requires two host bus transactions: One ITF Status read and one burst write to ITF

† This bit or bits are new to the TSB12LV01A and do not exist in the TSB12C01A.

3.2.12 GRF Status Register (@3Ch)

The GRF status register allows access to the registers that control or monitor the GRF. The register is at address 3Ch. All the FIFO flag bits are read only, and the FIFO control bits are read/write. Its initial value is 0000_0000h.

Table 3–12. GRF Status Register

BITS	ACRONYM	FUNCTION NAME	DESCRIPTION
0†	Empty	GRF empty flag	When Empty is set, the GRF is empty.
1†	cd	GRF controller bit	If cd is 1, a packet token is on the top of GRF. The next GRF read returns the packet token.
2†	PacCom	Packet complete	When cd=1 and PacComp=1 then the next block of data from the GRF is the last one for the packet. When cd=1 and PacComp=0, then the next block of data from the GRF is just one block of the current receive packet. If the trigger size function is disabled or flush bad packet function is enabled, cd=1 and PacComp is 1. This means each received packet only contains one block of GRF data. When cd=0 PacCom is not valid.
3–12†	GRFTotal Count	Total GRF data count stored in quadlet	GRF stored data count which includes all stored received packets and internally-generated packet tokens.
13–22†	GRFSize	GRF size	GRF Size=512–(ATFSize+ITFSize) GRF Size is total assigned space for GRF
23–31†	WriteCount	Received data quadlet count of next block in GRF	This number is valid when cd bit is 1. It indicates the received data quadlet count of next block. Write count also contains the packet token. The packet token is always stored on the top of each receive data block to provide status report, so software can burst read the next block from GRF. For the case of disable trigger size function or enable flush bad receive packets: To read each received packet from GRF, first read GRF status register and make sure cd=1 so the packet token is on the top of GRF. Next do burst read from GRF to read (WriteCount+1) quadlet, which includes the packet token. In cases when the trigger size function enable and FhBad is 0 : read each block of received data as above, until PacCom is 1, which indicates that the block is the ending block of the current packet.

† This bit or bits are new to the TSB12LV01A and do not exist in the TSB12C01A.

3.3 FIFO Access

Access to all the transmit FIFOs is fundamentally the same; only the address to where the write is made changes.

3.3.1 General

The TSB12LV01A controller FIFO-access address map shown in Figure 3–3 illustrates how the FIFOs are mapped. The suffix `_First` denotes a write to the FIFO location where the first quadlet of a packet should be written when the writer wants to transmit the packet. The first quadlet is held in the FIFO until a quadlet is written to an update location.

The suffix `_Continue` denotes a write to the FIFO location where the second through $n-1$ quadlets of a packet should be written.

The second through $n-1$ quadlets are held in the FIFO until a quadlet is written to an update location.

The suffix `Continue & Update` denotes a write to the FIFO location where the last quadlet of a multiple quadlet packet should be written. Another method allows the second through n quadlets of a packet to be written to an address with this suffix when the writer wants the packet to be transmitted as soon as possible. However, in this case the writes to the FIFO must be put into the FIFO faster than data is removed from the FIFO and placed on the 1394 bus or an error will result.

	0	1	2	3	4	5	6	7	8	9	10	11	12	13	14	15	16	17	18	19	20	21	22	23	24	25	26	27	28	29	30	31
80h	ATF_First																															
84h	ATF_Continue																															
88h	Reserved																															
8Ch	ATF_Continue & Update																															
90h	ITF_First																															
94h	ITF_Continue																															
98h	Reserved																															
9Ch	ITF_Continue & Update																															
A0h	ATF Burst Write (see Note A)																															
A4h	Reserved																															
A8h	Reserved																															
ACh	Reserved																															
B0h	ITF Burst Write (see Note A)																															
B4h	Reserved																															
B8h	Reserved																															
BCh	Reserved																															
C0h	GRF Data																															
C4h	Reserved																															
C8h	Reserved																															
CCh	Reserved																															

NOTE A. These are new to the TSB12LV01A and do not exist in the TSB12C01A.

Figure 3–3. TSB12LV01A Controller-FIFO-Access Address Map

3.3.2 ATF Access

The procedure to access to the ATF is as follows:

1. Write the first quadlet of the packet to ATF location 80h: the data is not confirmed for transmission.
2. Write the second to n-1 quadlets of the packet to ATF location 84h: Can use burst write to write (n-2) quadlets into ATF, which requires only one host write transaction, the data is not confirmed for transmission.
3. Write the final quadlet of the packet to ATF location 8Ch: The data is confirmed for transmission. This location supports burst write.

If the first quadlet of a packet is not written to the ATF_First address, the transmitter enters a state denoted by an ATBadF interrupt. An underflow of the ATF also causes an ATBadF interrupt. When this state is entered, no asynchronous packets can be sent until the ATF is cleared via the CLR ATF control bit. Isochronous packets can be sent while in this state. For example, if an asynchronous write request packet is addressed to a nonexistent address, the TSB12LV01A waits until a time out occurs and then sets ATAck (in the node address register) to 1_0000b. After the asynchronous command is sent, the sender reads ATAck. If ATAck = 1_0000b, then a time out has occurred (i.e., no response from any node was received).

ATF access example:

The first quadlet of n quadlets is written to ATF location 80h. Quadlets (2 to n-1) are written to ATF location 84h. The last quadlet (nth) is written to ATF location 8Ch. If the ATFEmpty bit is true, it is set to false and the TSB12LV01A requests the phy layer to arbitrate for the bus. To ensure that an ATF underflow condition does not occur, loading of the ATF in this manner is suggested.

After loading the ATF with an asynchronous packet and sending it, the software driver needs to wait until the TxRdy bit (bit 5) of the Interrupt register is set to 1 before reading ATAck. When TxRdy is set to 1, this indicates that the transmitter has received an ACK or time out. So the correct ATAck can then be read from the node address register. In order to receive the next Ack code, the TxRdy bit needs to be cleared to 0.

Writing to 80h (ATF_First) causes DATA0–DATA31 to be written into the ATF and sets the control bit to 1 to indicate the first quadlet of the packet, but the data is not confirmed for transmission.

It is allowed to burst write to 84h(ATF_Continue), which allows multiple quadlets to load into ATF, but the data is not confirmed for transmission.

It is allowed to burst write to 8Ch (ATF_Continue & Update), which allows multiple quadlets to load into ATF, and the data is confirmed for transmission. If consecutive writes to ATF_Continue & Update do not keep up with data being put on the 1394 bus, an ATF underflow error will occur.

Write to address A0h (ATF burst write) writes the whole packet into ATF. The first quadlet written into ATF has the control bit set to 1 to indicate this is the first quadlet of the packet, and the rest of the quadlets have the control bit set to 0. The last quadlet written into ATF confirms the packet for transmission.

To do burst write host bus master continuously drive CSZ low, TSB12LV01A loads DATA0–DATA31 to ATF during each rising edge of BCLK when CSZ is low and at the same time it asserts CAZ and CAZ is one cycle behind CSZ. The control bit is 0 for ATF_Continue and ATF_Continue & Update.

ATF access example:

Assume there are n quadlets need to write to ATF for transmission.

Example 3–1. Non-Burst Write

80h (ATF_First) DATA1[0:31]
84h (ATF_Continue) DATA2[0:31]
.
.
84h (ATF_Continue) DATA(n–1)[0:31]
8Ch (ATF_Continue & Update) DATAn[0:31]

Example 3–2. Allowable Burst Write

80h (ATF_First) DATA1[0:31]
84h (ATF_Continue) (burst write) DATA2[0:31], DATA3[0:31],, DATA(n–1)[0:31]
8Ch (ATF_Continue & Update) DATAn[0:31]

Example 3–3. Allowable Burst Write, But Riskier

80h (ATF_First) DATA1[0:31]
8Ch (ATF_Continue & Update) (burst write) DATA2[0:31], DATA3[0:31],, DATA(n–1)[0:31], DATAn[0:31]

NOTE:

If writes to ATF_Continued & update do not keep up with data being put on the 1394 bus, an ATF underflow error will occur.

Example 3–4. Allowable Burst Write

A0h (ATF burst write) DATA1[0:31], DATA2[0:31],, DATA(n–1)[0:31], DATAn[0:31]

Example 3–4 only requires one host bus write transaction. The packet is stored in the ATF in the following format:

{1, DATA1[0:31]}
{0, DATA2[0:31]}
{0, DATA3[0:31]}
.
.
{0, DATA(n–1)[0:31]}
{0, DATAn[0:31]}

3.3.3 ITF Access

The procedure to access to the ITF is as follows:

1. Write to ITF location 90h: the data is not confirmed for transmission (first quadlet of the packet).
2. Write to ITF location 94h: the data is not confirmed for transmission (second to n–1 quadlets of the packet). It is allowed to burst write to ITF_Continue.
3. Write to ITF location 9Ch: the data is confirmed for transmission (last quadlet of the packet). It is allowed to burst write to ITF_Continue & Update.

If the first quadlet of a packet is not written to the ITF_First, the transmitter enters a state denoted by an IFBadF interrupt. An underflow of the ITF also causes an IFBadF interrupt. When this state is entered, no isochronous packets can be sent until the ITF is cleared by the CLR ITF control bit. Asynchronous packets can be sent while in this state.

Example 3–5. ITF Access

The first quadlet of n quadlets is written to ITF location 90h. Quadlets (2 to n–1) are written to ITF location 94h. The last quadlet (nth) is written to ITF location 9Ch. If the ITFEmpty is true, it is set to false and the TSB12LV01A requests the phy layer to arbitrate for the bus. To ensure that an ITF underflow condition does not occur, loading of the ITF in this manner is suggested.

Writing to 90h(ITF_First) writes DATA0–DATA31 into the ITF and sets the control bit to 1 to indicate the first quadlet of the packet, but the data is not confirmed for transmission.

It is allowed to burst write to 94h(ITF_Continue), which allows multiple quadlets to load into ITF, but the data is not confirmed for transmission. If bursting writes to ITF_Continue & Update do not keep up with data being put on the 1394 bus, an ITF underflow error will occur.

Writing to 9Ch (ITF_Continue & Update), which allows multiple quadlets to load into ITF, the data is confirmed for transmission.

Writing to address B0h (ITF burst write) writes the whole packet into ITF. The first quadlet written into ITF has the control bit set to 1 to indicate this is the first quadlet of the packet. The termination of the burst write on the host interface confirms the packet for transmission.

ITF access example:

Assume there are n quadlets need to write to ITF for transmission.

Example 3–6. Non-Burst Write

```
90h (ITF_First)    DATA1[0:31]
94h (ITF_Continue) DATA2[0:31]
.
.
.
.
94h (ITF_Continue) DATA(n–1)[0:31]
9Ch (ITF_Continue & Update) DATAn[0:31]
```

Example 3–7. Allowable Burst Write

```
90h (ITF_First)    DATA1[0:31]
94h (ITF_Continue) (burst write) DATA2[0:31], DATA3[0:31], ..... , DATA(n–1)[0:31]
9Ch (ITF_Continue & Update) DATAn[0:31]
```

Example 3–8. Allowable Burst Write, But Riskier

```
90h (ITF_First)    DATA1[0:31]
9Ch (ITF_Continue & Update) (burst write) DATA2[0:31], DATA3[0:31], ....., DATA(n–1)[0:31],
DATAn[0:31].
```

NOTE:

If consecutive writes to ITF_Continue & Update do not keep up with data being put on the 1394 bus, an ITF underflow error will occur.

Example 3–9. Allowable Burst Write

```
B0h (ITF burst write) DATA1[0:31], DATA2[0:31], ....., DATA(n–1)[0:31], DATAn[0:31]
```

Example 3–9 only requires one host bus write transaction. The packet stores in ITF as following format:

```
{1, DATA1[0:31]}
{0, DATA2[0:31]}
{0, DATA3[0:31]}
.
.
.
{0, DATA(n–1)[0:31]}
{0, DATAn[0:31]}
```

3.3.4 General-Receive FIFO (GRF)

Access to the GRF is done with a read from the GRF, which requires a read from address C0h.

Read from the GRF can be done in burst mode. Before reading the GRF, check whether the RxDta interrupt is set, which indicates data stored in GRF is ready to read. The GRF status register may also be read and the cd bit checked if it is 1 and the write count is greater than 0. The cd bit is equal to 1 means the packet token is on top of GRF. The whole block of data contains one packet token followed by received quadlets equal to the write count.

When packet token is read, it has the following format:

- Bit 0–6 reserved
- Bit 7–10 ackSnpd. When snoop mode is enabled, this field indicates the acknowledge seen on the bus after the packet is received. If snoop mode is disabled, ackSnpd contains 4'b0.
- Bit 11 PacComp – same value as in the GRF status register when cd bit is 1. PacComp means packet complete. If PacComp is 1, this block is the last block of this packet or this block contains the whole receive packet.
- Bit 12 EnSp (bit0 of diagnostic register). If EnSp is 1, GRF contains snooped packets which includes asynchronous packets and isochronous packets. When snoop mode is enabled, all header and data CRC quadlets are stored in the GRF.
- Bit 13–14 RcvPktSpd – receive packet speed
 - 00 – 100 Mbits/s
 - 01 – 200 Mbits/s
 - 10 – 400 Mbits/s
- Bit 15–23 WriteCount – quadlet count in this block excluding packet token. WriteCount is the same number shown in GRF status register when cd bit is 1.
- Bit 24–27 Tcode – received packet tcode. For received self-ID packets, phy configuration and Link-on packets, the Tcode field contains 4'b1110 to indicate these special packets.
- Bit 28–31 Ack – Ack code sent to the transmit node for this packet when PacComp = 1. If PacComp = 0, this field is don't care. If EnSp is 1(snoop mode is enabled), this field indicates whether the entire packet snooped was correctly. For received Phy configuration and Link-on packets, this field is 4'b0000.

If trigger size function is enabled, RxDta interrupt triggers whenever each block in GRF is available for read for the same long received packet. To enable trigger size, TrgEn of control register should set to 1 , FhBad of control register should be cleared to 0 and trigger size of FIFO control register should be set to greater than 5. Therefore, the trigger size function does not apply to receive self-ID packets, phy configuration packets, link-on packets, or quadlet read or write packets.

As an example, if a read response for data block packet is received at 400 Mbits/s, total received data is 14 quadlets excluding header CRC and data CRC, trigger size function is enabled, and trigger size is 6. The packet token is shown in hex format.

The following example generates three RxDta interrupts.

The data is stored in GRF as follows:

```
{1, 0004_0670}    <- first packet token, PacComp = 0
{0, quadlet_1[0:31]}
{0, quadlet_2[0:31]}
{0, quadlet_3[0:31]}
```

```

{0, quadlet_4[0:31]}
{0, quadlet_5[0:31]}
{0, quadlet_6[0:31]}

{1, 0004_0670}    ← second packet token, PacComp = 0
{0, quadlet_7[0:31]}
{0, quadlet_8[0:31]}
{0, quadlet_9[0:31]}
{0, quadlet_10[0:31]}
{0, quadlet_11[0:31]}
{0, quadlet_12[0:31]}
{1, 0014_0271}    ← the last packet token, PacComp = 1, Ack = 4'0001
{0, quadlet_13[0:31]}
{0, quadlet_14[0:31]}

```

This following example generates one RxDta interrupt. If the trigger size function is disabled, the data is stored in the GRF as follows:

```

{1, 0014_0E71}    ← packet token, PacComp = 1, WriteCount = 14, Ack = 4'0001
{0, quadlet_1[0:31]}
{0, quadlet_2[0:31]}
{0, quadlet_3[0:31]}
{0, quadlet_4[0:31]}
{0, quadlet_5[0:31]}
{0, quadlet_6[0:31]}
{0, quadlet_7[0:31]}
{0, quadlet_8[0:31]}
{0, quadlet_9[0:31]}
{0, quadlet_10[0:31]}
{0, quadlet_11[0:31]}
{0, quadlet_12[0:31]}
{0, quadlet_13[0:31]}
{0, quadlet_14[0:31]}

```

3.3.5 RAM Test Mode

The purpose of RAM test mode is to test the RAM with writes and reads. During RAM test mode, RAM, which makes up the ATF, ITF, and GRF, is accessed directly from the host bus. Different data is written to and read back from the RAM and compared with what was expected to be read back. ATF status, ITF status, and GRF status are not changed during RAM test mode, but the stored data in RAM is changed by any write transaction. To enable RAM test mode, set RAMTest bit of the ATF Status register. Before beginning any read or write to the RAM, the ADr_clr bit of the ATF Status register should be set to clear ConErr. This action also clears the ADr_clr bit.

During RAM test mode, the host bus address should be C0h. The first host bus transaction (either read or write) accesses location 0 of the RAM. The second host bus transaction accesses location 1 of the RAM. The nth host bus transaction accesses location n-1 of the RAM. After each transaction, the internal RAM address counter is incremented by one.

The RAM has 512 locations with each location containing 33 bits. The most significant bit is the control bit. When the control bit is set, that indicates the quadlet is the start of the packet. In order to set the control bit, control bit of the ATF status register has to be set. In order to clear the control bit, control bit of the ATF status register has to be cleared. When a write occurs, the 32 bits of data from the host bus is written to the low order 32 bits of the RAM and the value in control-bit1 is written to the control bit. When a read occurs, the low order 32 bits of RAM are sent to the host data bus and the control bit is compared to the control bit of the ATF Status register. If the control bit and control bit of the ATF status register, ConErr of ATF status

register is set. This does not stop operation and another read or write can immediately be transmitted. To clear Control_bit_err, set Adr_clr of the ATF status register.

Another way to access specific location in the RAM during RAM test mode is to write desired value to AdrCounter of ATF Status register. The next RAM test read or write accesses the location pointed by AdrCounter. AdrCounter contains current RAM address in RAM test mode

During RAM test mode any location inside FIFO can be accessed by writing the address to AdrCounter of ATF status register. Each read or write accesses the location pointed by AdrCounter and AdrCounter increments by 1 after each transaction. Set AdrClr of ATF status register clears the AdrCounter to 0 and clear ConErr of ATF status register to 0. Setting Control1 (bit 4) of ATF status register to 1 writes control bit with 1 for RAM test write transaction.

Set RAMTest (bit 5) of ATF Status register to 1 to enable RAM Test mode. A write to Address C0h writes {Control1, DATA0–DATA31} to the location pointed by AdrCounter. A read from Address C0h reads from the location pointed by AdrCounter. Control bit value can be determined by checking ConErr (bit 2) and Control1(bit 4) of ATF status register.

Table 3–13. Control Bit Value

ConErr	Control1	Control Bit Value
1	1	0
0	1	1
1	0	1
0	0	0

Another way to read the control bit value is to read the cd bit (bit 1) of the GRF status register before reading a quadlet from address C0h in RAM test mode. The cd bit contains the control bit value pointed to by the current address counter.

ATF start address is 0. ITF start address is equal to ATF size. GRF start address is equal to (ATF size + ITF size). FIFO operation temporarily stops during RAM test mode. Clear RAMTest (bit 5) of ATF status register to 0 resumes normal FIFO operation.

4 TSB12LV01A Data Formats

The data formats for transmission and reception of data are shown in the following sections. The transmit format describes the expected organization of data presented to the TSB12LV01A at the host–bus interface. The receive formats describe the data format that the TSB12LV01A presents to the host–bus interface.

4.1 Asynchronous Transmit (Host Bus to TSB12LV01A)

Asynchronous transmit refers to the use of the asynchronous–transmit FIFO (ATF) interface. The general–receive FIFO (GRF) is shared by asynchronous data and isochronous data. There are two basic formats for data to be transmitted and received: the first is for quadlet packets, and the second is for block packets. For transmits, the FIFO address indicates the beginning, middle, and end of a packet. For receives, the data length, which is found in the header of the packet, determines the number of bytes in the data of a block packet.

4.1.1 Quadlet Transmit

The quadlet-transmit format is shown in Figure 4–1. The first quadlet contains packet control information. The second and third quadlets contain the 64-bit, quadlet-aligned address. The fourth quadlet is data used only for write requests and read responses. For read requests and write responses, the quadlet data field is omitted.

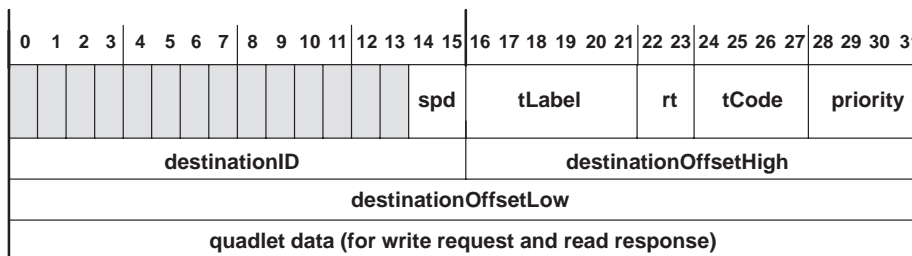


Figure 4–1. Quadlet-Transmit Format

Table 4–1. Quadlet-Transmit Format

FIELD NAME	DESCRIPTION
spd	This field indicates the speed at which this packet is to be sent. 00 = 100 Mbits/s, 01 = 200 Mbits/s, and 10 = 400 Mbits/s, and 11 is undefined for this implementation.
tLabel	This field is the transaction label, which is a unique tag for each outstanding transaction between two nodes. This is used to pair up a response packet with its corresponding request packet.
rt	The retry code for this packet is: 00 = new, 01 = retry_X, 10 = retryA, and 11 = retryB.
tCode	tCode is the transaction code for this packet (see Table 6–10 of IEEE 1394-1995 standard).
priority	The priority level for this packet. For cable implementation, the value of the bits must be 0. For backplane implementation, see clause 5.4.1.3 and 5.4.2.1 of the IEEE 1394-1995 standard.
destinationID	This is the concatenation of the 10-bit bus number and the 6-bit node number that forms the destination node address of this packet.
destination OffsetHigh, destination OffsetLow	The concatenation of these two fields addresses a quadlet in the destination nodes address space. This address must be quadlet aligned (modulo 4).
quadlet data	For write requests and read responses, this field holds the data to be transferred. For write responses and read requests, this field is not used and should not be written into the FIFO.

4.1.2 Block Transmit

The block-transmit format is shown in Figure 4–2. The first quadlet contains packet-control information. The second and third quadlets contain the 64-bit address.

The first 16 bits of the fourth quadlet contain the dataLength field. This is the number of bytes of data in the block data section of the packet. The remaining 16 bits represent the extended_tCode field. (See Table 6–11 of the IEEE 1394–1995 standard for more information on extended_tCodes.) The block data, if any, follows the extended_tCode. Block write responses are identical to the quadlet write response and use the format described in subsection 4.1.3.

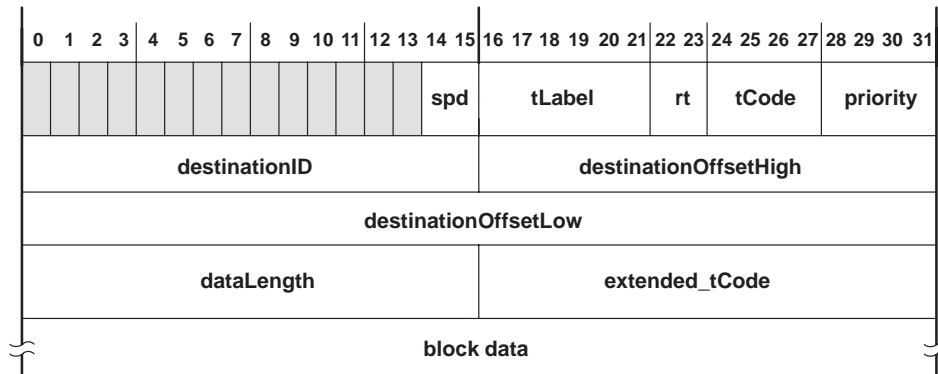


Figure 4–2. Block-Transmit Format

Table 4–2. Block-Transmit Format Functions

FIELD NAME	DESCRIPTION
spd	This field indicates the speed at which this packet is to be sent. 00 = 100 Mb/s, 01 = 200 Mb/s, and 10 = 400 Mb/s, and 11 is undefined for this implementation.
tLabel	This field is the transaction label, which is a unique tag for each outstanding transaction between two nodes. This is used to pair up a response packet with its corresponding request packet.
rt	The retry code for this packet is 00 = new, 01 = retry_X, 10 = retryA, and 11 = retryB.
tCode	tCode is the transaction code for this packet (see Table 6–10 of IEEE 1394-1995 standard).
priority	The priority level for this packet. For cable implementation, the value of the bits must be 0. For backplane implementation, see clause 5.4.1.3 and 5.4.2.1 of the IEEE 1394-1995 standard.
destinationID	This is the concatenation of the 10-bit bus number and the 6-bit node number that forms the node address to which this packet is being sent.
destination OffsetHigh, destination OffsetLow	The concatenation of these two fields addresses a quadlet in the destination node's address space. This address must be quadlet aligned (modulo 4). The upper four bits of the destination OffsetHigh field are used as the response code for lock-response packets and the remaining bits are reserved.
dataLength	The number of bytes of data to be transmitted in the packet.
extended_tCode	This field is the block extended_tCode to be performed on the data in this packet. See Table 6–11 of the IEEE 1394-1995 standard.
block data	The data to be sent. If dataLength is 0, no data should be written into the FIFO for this field. Regardless of the destination or source alignment of the data, the first byte of the block must appear in byte 0 of the first quadlet.

4.1.3 Quadlet Receive

The quadlet-receive format is shown in Figure 4–3. The first quadlet read from the FIFO is the packet token described in Section 3.3.4. The first 16 bits of the second quadlet contain the destination node and bus ID, and the remaining 16 bits contain packet–control information. The first 16 bits of the third quadlet contain the node and bus ID of the source, and the remaining 16 bits of the third quadlet and the entire fourth quadlet contain the 48–bit, quadlet–aligned destination offset address. The fifth quadlet contains data used by write requests and read responses. For read requests and write responses, the quadlet data field is omitted. The first quadlet (the packet token) contains packet–reception status, added by the TSB12LV01A.

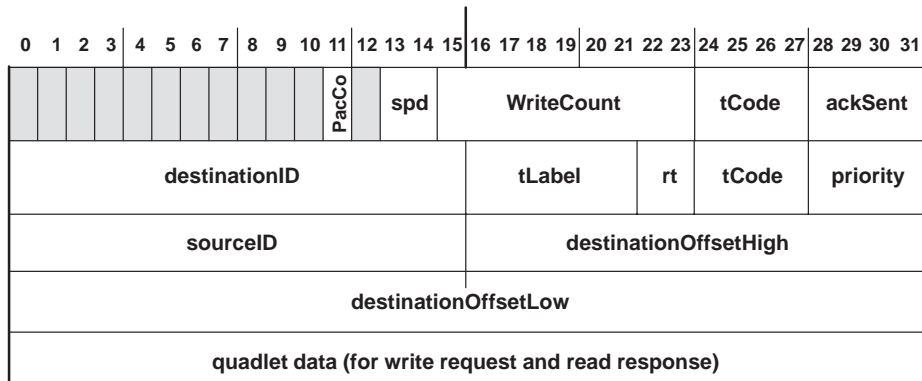


Figure 4–3. Quadlet-Receive Format

Table 4–3. Quadlet-Receive Format Functions

FIELD NAME	DESCRIPTION
PacCo	Packet complete. When PacCo = 1, the next block of data is the last one for the packet. When PacCo = 0, the next block of data is just another block of the current packet.
spd	This field indicates the speed at which this packet was sent. 00 = 100 Mbits/s, 01 = 200 Mbits/s, 10 = 400 Mbits/s, and 11 is undefined for this implementation.
WriteCount	WriteCount indicates the number of data quadlets in the packet.
tCode	tCode is the transaction code for this packet (See Table 6–10 of the IEEE 1394-1995 standard).
ackSent	This field holds the acknowledge sent by the receiver for this packet. (See Table 6–13 of the IEEE 1394-1995 standard).
destinationID	This is the concatenation of the 10-bit bus number and the 6-bit node number that forms the node address to which this packet is being sent.
tLabel	This field is the transaction label, which is a unique tag for each outstanding transaction between two nodes. This is used to pair up a response packet with its corresponding request packet.
rt	The retry code for this packet is 00 = new, 01 = retry_X, 10 = retryA, and 11 = retryB.
priority	The priority level for this packet. For cable implementation, the value of the bits must be zero. For backplane implementation, see clause 5.4.1.3 and 5.4.2.1 of the IEEE 1394-1995 standard.

Table 4–3. Quadlet-Receive Format Functions (Continued)

FIELD NAME	DESCRIPTION
sourceID	This is the node ID of the sender of this packet.
destination OffsetHigh, destination OffsetLow	The concatenation of these two fields addresses a quadlet in the destination nodes address space. This address must be quadlet aligned (modulo 4). (The upper four bits of the destination OffsetHigh field are used as the response code for lock-response packets, and the remaining bits are reserved.)
quadlet data	For write requests and read responses, this field holds the transferred data. For write responses and read requests, this field is not present.

4.1.4 Block Receive

The block-receive format is shown in Figure 4–4. The first quadlet read from the FIFO is the packet token described in Section 3.3.4. The first 16 bits of the second quadlet contain the destination node and bus ID, and the remaining 16 bits contain packet–control information. The first 16 bits of the third quadlet contain the node and bus ID of the source, and the remaining 16 bits of the third quadlet and the entire fourth quadlet contain the 48–bit, quadlet–aligned destination offset address. The first 16 bits of the fifth quadlet contain the dataLength field. This is the number of bytes of data in the block data section of the packet. The remaining 16 bits represent the extended_tCode field. (See Table 6–11 of the IEEE 1394–1995 standard for more information on extended_tCodes.) The block data, if any, follows the extended_tCode.

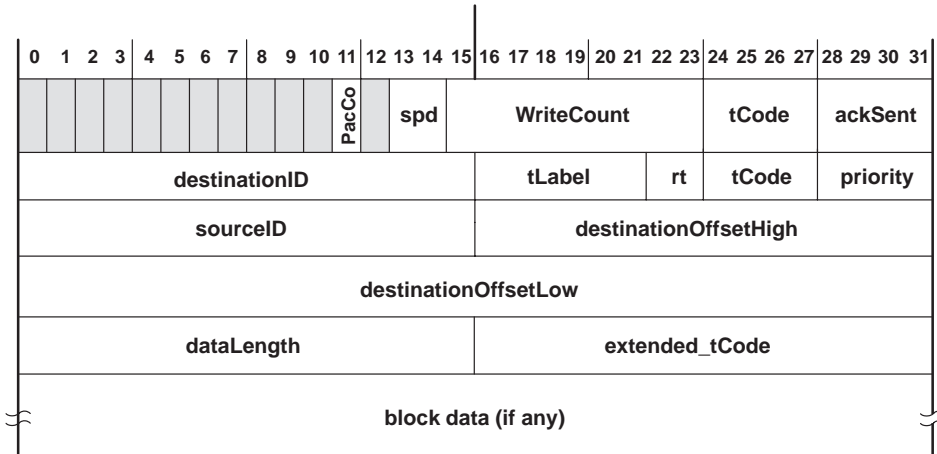


Figure 4–4. Block-Receive Format

Table 4–4. Block-Receive Format Functions

FIELD NAME	DESCRIPTION
PacCo	Packet complete. When PacCo = 1, the next block of data is the last one for the packet. When PacCo = 0, the next block of data is just another block of the current packet.
spd	This field indicates the speed at which this packet was sent. 00 = 100 Mbits/s, 01 = 200 Mbits/s, 10 = 400 Mbits/s, and 11 is undefined for this implementation.
WriteCount	WriteCount indicates the number of data quadlets in the packet.
tCode	tCode is the transaction code for this packet. (See Table 6–10 of the IEEE 1394-1995 standard).
ackSent	This field holds the acknowledge sent by the receiver for this packet (See Table 6–13 of the IEEE 1394-1995 standard).
destinationID	This is the concatenation of the 10-bit bus number and the 6-bit node number that forms the node address to which this packet is being sent.
tLabel	This field is the transaction label, which is a unique tag for each outstanding transaction between two nodes. This is used to pair up a response packet with its corresponding request packet.
rt	The retry code for this packet is 00 = new, 01 = retry_X, 10 = retryA, and 11 = retryB.
priority	This field contains the priority level for this packet. For cable implementation, the value of the bits must be zero. For backplane implementation, see clause 5.4.1.3 and 5.4.2.1 of the IEEE 1394-1995 standard.
sourceID	This is the node ID of the sender of this packet.
destination OffsetHigh, destination OffsetLow	The concatenation of these two fields addresses a quadlet in the destination nodes address space. This address must be quadlet aligned (modulo 4). The upper four bits of the destination OffsetHigh field are used as the response code for lock-response packets and the remaining bits are reserved.
dataLength	For write request, read responses, and locks, this field indicates the number of bytes being transferred. For read requests, this field indicates the number of bytes of data to be read. A write-response packet does not use this field. Note that the number of bytes does not include the header, only the bytes of block data.
extended_tCode	The block extended_tCode to be performed on the data in this packet. See Table 6–11 of the IEEE 1394-1995 standard.
block data	This field contains any data being transferred for this packet. Regardless of the destination address or memory alignment, the first byte of the data appears in byte 0 of the first quadlet of this field. If needed, the last quadlet of this field is padded with zeros out to four bytes.

4.2 Isochronous Transmit (Host Bus to TSB12LV01A)

The format of the isochronous-transmit packet is shown in Figure 4–5. The data for each channel must be presented to the isochronous-transmit FIFO interface in this format in the order that packets are to be sent. The transmitter requests the bus to send any packets available at the isochronous-transmit interface immediately following reception or transmission of the cycle-start message.

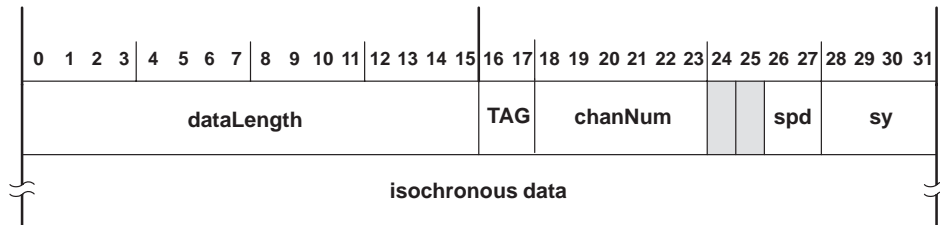


Figure 4–5. Isochronous-Transmit Format

Table 4–5. Isochronous-Transmit Functions

FIELD NAME	DESCRIPTION
dataLength	This field indicates the number of data bytes in this packet
TAG	This field indicates the format of data carried by the isochronous packet (00 = formatted, 01 = IEC 61883 CIP headers, 10 and 11 are reserved).
chanNum	This field carries the channel number with which this data is associated.
spd	This field contains the speed at which to send this packet.
sy	This field carries the transaction layer-specific synchronization bits.
isochronous data	This field contains the data to be sent with this packet. The first byte of data must appear in byte 0 of the first quadlet of this field. If the last quadlet does not contain four bytes of data, the unused bytes should be padded with zeros.

4.3 Isochronous Receive (TSB12LV01A to Host Bus)

The format of the isochronous-receive data is shown in Figure 4–6. The data length, which is found in the header of the packet, determines the number of bytes in an isochronous packet.

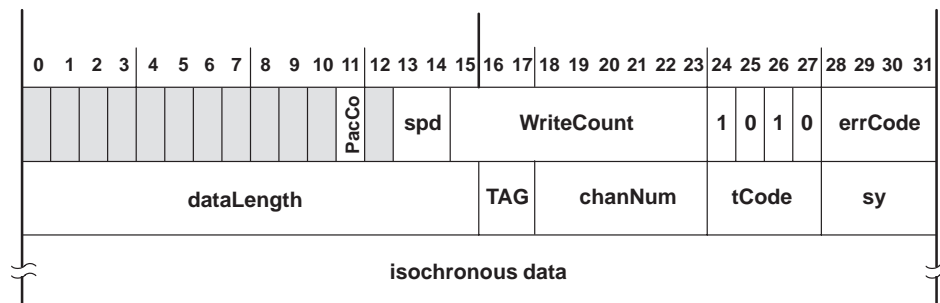


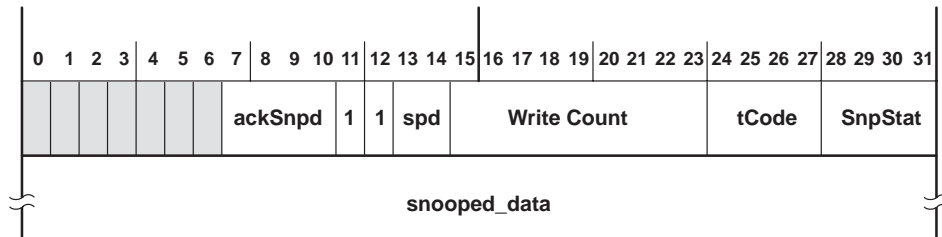
Figure 4–6. Isochronous-Receive Format

Table 4–6. Isochronous-Receive Functions

FIELD NAME	DESCRIPTION
PacCo	Packet complete. When PacCo = 1, the next block of data is the last one for the packet. When PacCo = 0, the next block of data is just another block of the current packet.
spd	This field indicates the speed at which this packet was sent. 00 = 100 Mbits/s, 01 = 200 Mbits/s, 10 = 400 Mbits/s, and 11 is undefined for this implementation.
WriteCount	WriteCount indicates the number of data quadlets in the packet.
errCode	This field indicates whether this packet was received correctly. The possibilities are Complete, DataErr, or CRCErr and have the same encoding as the corresponding acknowledge codes (see Table 6–13 in the IEEE Standard 1394–1995).
dataLength	This field indicates the number of bytes in this packet
TAG	This field indicates the format of data carried by isochronous packet (00 = formatted, 01 = IEC 61883 CIP headers, 10 and 11 are reserved).
chanNum	This field contains the channel number with which this data is associated.
tCode	This field carries the transaction code for this packet (tCode = Ah).
sy	This field carries the transaction layer-specific synchronization bits.
isochronous data	This field has the data to be sent with this packet. The first byte of data must appear in byte 0 of the first quadlet of this field. The last quadlet should be padded with zeros.

4.4 Snoop Receive

The format of the snoop data is shown in Figure 4–7. The receiver module can be directed to receive any and all packets that pass by on the serial bus. In this mode, the receiver presents the data received to the receive-FIFO interface.



- NOTES: A. Bit 12 PacComp=1
 B. Bit 13 EnSp(bit 0 of Diagnostic Register) = 1

Figure 4–7. Snoop Format

Table 4–7. Snoop Functions

FIELD NAME	DESCRIPTION
ackSnpd	This field indicates the acknowledge seen on the bus after the packet is received.
spd	This field indicates the speed at which this packet was sent. 00 = 100 Mbits/s, 01 = 200 Mbits/s, 10 = 400 Mbits/s, and 11 is undefined for this implementation.
WriteCount	WriteCount indicates the number of data quadlets in the packet.
tCode	tCode is the transaction code for this packet (See Table 6–10 of the IEEE 1394-1995 standard).
snpStat	This field indicates whether the entire packet snooped was received correctly. A value equal to the Ack_complete acknowledge code indicates complete reception. This field has the same encoding as the corresponding acknowledge codes (See Table 6–13 of the IEEE 1394-1995 standard).
snooped_data	This field contains the entire packet received or as much as could be received.

4.5 Phy Configuration Transmit

The transmit format of the phy configuration packet is shown in Figure 4–8. The phy configuration packet contains three quadlets, which are loaded in the ATF. The first quadlet is the tCode for an unformatted packet. This is written into ATF_First at address 80h and has a value of 0000_00E0h. The second quadlet consists of actual data. This is written into the ATF_Continue at address 84h and has a value of the first quadlet of the phy configuration packet. The third quadlet is almost the inverse of the second quadlet. The first 16 bits of the third quadlet are the inverse of the first 16 bits of the second quadlet. The final 16 bits of the third quadlet are all ones (1). This is written into the ATF_Continue & Update at address 8Ch and has a value of the second quadlet of the phy configuration packet.

There is a possibility of a false header error on receipt of a phy configuration packet. If the first 16 bits of a phy configuration packet (see Figure 4–8) happen to match the destination identifier of a node (bus number and node number), the TSB12LV01A on that node issues a header error since the node misinterprets the phy configuration packet as a data packet addressed to the node. The suggested solution to this potential problem is to assign bus numbers that all have the most significant (MS) bit set to 1. Since the all-ones case is reserved for addressing the local bus, this leaves only 511 available unique bus identifiers. This is an artifact of the IEEE 1394-1995 standard.

0	1	2	3	4	5	6	7	8	9	10	11	12	13	14	15	16	17	18	19	20	21	22	23	24	25	26	27	28	29	30	31													
0	0	0	0	0	0	0	0	0	0	0	0	0	0	0	0	0	0	0	0	0	0	0	0	1	1	1	0	0	0	0	0													
0	0	root_ID				R	T	gap_cnt				0	0	0	0	0	0	0	0	1	1	1	1	0	0	0	0	0	0	0														
logical inverse of first 16 bits of first quadlet																1	1	1	1	1	1	1	1	1	1	1	1	1	1	1	1	1	1	1	1	1	1	1	1	1	1	1	1	1

Figure 4–8. Phy Configuration Format

Table 4–8. Phy Configuration Functions

FIELD NAME	DESCRIPTION
00	This field is the phy configuration packet identifier.
root_ID	This field is the physical_ID of the node to have its force_root bit set (only meaningful when R is set).
R†	When R is set, the force-root bit of the node identified in root_ID is set and the force_root bit of all other nodes are cleared. When R is cleared, root_ID is ignored.
T†	When T is set, the PHY_CONFIGURATION.gap_count field of all the nodes is set to the value in the gap_cnt field.
gap_cnt	This field contains the new value for PHY_CONFIGURATION.gap_count for all nodes. This value goes into effect immediately upon receipt and remains valid after the next bus reset. After the second reset, gap_cnt is set to 63h unless a new phy configuration packet is received.

† A phy configuration packet with R = 0, and T = 0 is reserved and is ignored when received.

4.6 Link-On Transmit

The transmit format of the link-on packet is shown in 9. The link-on packet contains three quadlets, which are loaded in the ATF. The first quadlet is the tCode for an unformatted packet. This is written into ATF_First at address 80h and has a value of 0000_00E0h. The second quadlet consists of actual data. This is written into the ATF_Continue at address 84h and has a value of the first quadlet of the link-on packet. The third quadlet is almost the inverse of the second quadlet. The first 16 bits of the third quadlet are the inverse of the first 16 bits of the second quadlet. The final 16 bits of the third quadlet are all ones (1). This is written into the ATF_Continue & Update at address 8Ch and has a value of the second quadlet of the link-on packet.

There is a possibility of a false header error on receipt of a link-on packet. If the first 16 bits of a link-on packet (see Figure 4–8) happen to match the destination identifier of a node (bus number and node number), the TSB12LV01A on that node issues a header error since the node misinterprets the link-on packet as a data packet addressed to the node. The suggested solution to this potential problem is to assign bus numbers that all have the most significant (MS) bit set to 1. Since the all-ones case is reserved for addressing the local bus, this leaves only 511 available unique bus identifiers. This is an artifact of the IEEE 1394-1995 standard.

0	1	2	3	4	5	6	7	8	9	10	11	12	13	14	15	16	17	18	19	20	21	22	23	24	25	26	27	28	29	30	31														
0	0	0	0	0	0	0	0	0	0	0	0	0	0	0	0	0	0	0	0	0	0	0	0	1	1	1	0	0	0	0	0														
0	1	PHY_ID					0	0	0	0	0	0	0	0	0	0	0	0	0	0	0	0	0	1	1	1	0	0	0	0	0														
logical inverse of first 16 bits of first quadlet																1	1	1	1	1	1	1	1	1	1	1	1	1	1	1	1	1	1	1	1	1	1	1	1	1	1	1	1	1	1

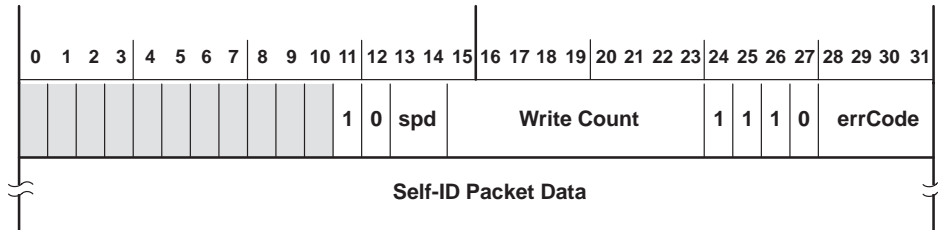
Figure 4–9. Link-On Format

Table 4–9. Link-On Functions

FIELD NAME	DESCRIPTION
01	This field is the link-on packet identifier.
PHY_ID	This field is the physical_ID of the node this packet is addressed to.

4.7 Receive Self-ID

The format of the receive self-ID packet is shown in Figure 4–10. The first quadlet is the packet token with the special tCode of Eh. The quadlets that follow are a concatenation of all received self-ID packets. See IEEE 1394-1995 standard, paragraph 4.3.4.1, for additional information about self-ID packets.



- NOTES: A. Bit 12 PacComp = 1
 B. Spd should be 2'b00

Figure 4–10. Receive Self-ID Format

Table 4–10. Isochronous-Receive Functions

FIELD NAME	DESCRIPTION
spd	This field indicates the speed at which this packet was sent (00 = 100 Mbits/s, 01 = 200 Mbits/s, 10 = 400 Mbits/s, and 11 is undefined).
WriteCount	WriteCount indicates the number of data quadlets in the packet.
errCode	This field indicates whether this packet was received correctly. The possibilities are Complete, DataErr, or CRCErr and have the same encoding as the corresponding acknowledge codes (see Table 6–13 in the IEEE Standard 1394-1995).
Self-ID packet data	This field contains a concatenation of all the self-ID packets received.

4.8 Received Phy Configuration and Link-On Packet

The format of the receive phy configuration and link-on packet is similar to self-ID. In the packet token the value of errCode is 4'b0000. Only the first quadlet of each packet is stored in GRF. If the received second quadlet of each quadlet is not inverse of the first one, the packet is ignored. See IEEE 1394-1995 standard, paragraph 4.3.4.2 for additional information on link-on packets, and paragraph 4.3.4.3 for all additional information on phy configuration packets.

5 Electrical Characteristics

5.1 Absolute Maximum Ratings Over Free-Air Temperature Range (Unless Otherwise Noted)[†]

Supply voltage range, V_{CC}	-0.5 V to 3.6 V
Supply voltage range, V_{CC5V}	-0.5 V to 5.5 V
Input voltage range, V_I (standard TTL/LVCMOS)	-0.5 V to $V_{CC} + 0.5$ V
Input voltage range, V_I (5-V standard TTL/LVCMOS)	-0.5 V to $V_{CC} + 0.5$ V
Output voltage range, (standard TTL/LVCMOS) V_O	-0.5 V to $V_{CC} + 0.5$ V
Output voltage range, (5-V standard TTL/LVCMOS) V_O	-0.5 V to $V_{CC} + 0.5$ V
Input clamp current, I_{IK} (TTL/LVCMOS) ($V_I < 0$ or $V_I > V_{CC}$) (see Note 1)	± 20 mA
Output clamp current, I_{OK} (TTL/LVCMOS) ($V_O < 0$ or $V_O > V_{CC}$) (see Note 2)	± 20 mA
Continuous total power dissipation	See Maximum Dissipation Rating Table
Operating free-air temperature range, T_A (TSB12LV01A)	0°C to 70°C
(TSB12LV01AI)	-40°C to 85°C
Storage temperature range, T_{stg}	-65°C to 150°C

[†] Stresses beyond those listed under “absolute maximum ratings” may cause permanent damage to the device. These are stress ratings only, and functional operation of the device at these or any other conditions beyond those indicated under “recommended operating conditions” is not implied. Exposure to absolute-maximum-rated conditions for extended periods may affect device reliability.

- NOTES: 1. This applies to external input and bidirectional buffers. For 5-V tolerant terminals, use $V_I > V_{CC5V}$.
 2. This applies to external output and bidirectional buffers. For 5-V tolerant terminals, use $V_O > V_{CC5V}$.

MAXIMUM DISSIPATION RATING TABLE

PACKAGE	$T_A \leq 25^\circ\text{C}$	DERATING FACTOR	$T_A = 70^\circ\text{C}$	$T_A = 85^\circ\text{C}$
	POWER RATING	ABOVE $T_A = 25^\circ\text{C}$	POWER RATING	POWER RATING
PZ	1500 mW	16.9 mW/°C	737 mW	486 mW

PACKAGE THERMAL CHARACTERISTICS[†]

PARAMETER	TEST CONDITIONS	PZ PACKAGE			WN PACKAGE			UNIT
		MIN	NOM	MAX	MIN	NOM	MAX	
$R_{\theta JA}$	Junction-to-ambient thermal impedance	Board mounted, No air flow			59			°C/W
$R_{\theta JC}$	Junction-to-case thermal impedance	13			8			°C/W
T_J	Junction temperature	115			175			°C

[†] Thermal characteristics vary depending on die and leadframe pad size as well as mold compound. These values represent typical die and pad sizes for the respective packages. The R value decreases as the die or pad sizes increases. Thermal values represent PWB bands with minimal amounts of metal.

5.2 Recommended Operating Conditions

		MIN	NOM	MAX	UNIT
Supply voltage, V_{CC}		3	3.3	3.6	V
Supply voltage, V_{CC5V}	5-V tolerant	4.5	5	5.5	V
Input voltage, V_I	TTL/LVCMOS	0		V_{CC}	V
	5-V tolerant	0		V_{CC5V}	
Output voltage, V_O^\dagger	TTL/LVCMOS	0		V_{CC}	V
	5-V tolerant	0		V_{CC5V}	
High-level input voltage, V_{IH}	TTL/LVCMOS	2		V_{CC}	V
	5-V tolerant	2		V_{CC5V}	
Low-level input voltage, V_{IL}	TTL/LVCMOS	0		0.8	V
	5-V tolerant	0		0.8	
Input transition time, (t_r , t_f) (10% to 90%)		0		6	ns
Operating free-air temperature, T_A	TSB12LV01A	0	25	70	°C
	TSB12LV01AI	-40	25	85	
Virtual junction temperature, T_{JC}^\ddagger		0	25	115	°C

[†] This applies to external output buffers.

[‡] The junction temperatures listed reflect simulation conditions. The absolute maximum junction temperature is 150°C. The customer is responsible for verifying the junction temperature.

5.3 Electrical Characteristics Over Recommended Ranges of Supply Voltage and Operating Free-Air Temperature (Unless Otherwise Noted)

PARAMETER	TEST CONDITIONS		MIN	TYP	MAX	UNIT
V_{OH} High-level output voltage		$I_{OH} = -8 \text{ mA}$, [†] TTL/LVCMOS	$V_{CC} - 0.6$			V
		$I_{OH} = -4 \text{ mA}$ [‡]	$V_{CC} - 0.6$			
V_{OL} Low-level output voltage		$I_{OL} = 8 \text{ mA}$, [†] TTL/LVCMOS	0.5			V
		$I_{OL} = 4 \text{ mA}$ [‡]	0.5			
V_{hys} Hysteresis ($V_{t+} - V_{t-}$)		TTL/LVCMOS	0.4			V
I_{IL} Low-level input current [§]	$V_I = V_{IL}(\text{min})$	TTL/LVCMOS	-1			μA
		5-V tolerant	-20			
		D0 – D3, CTL1, CTL2	-20			
I_{IH} High-level input current	$V_I = V_{IH}(\text{max})$	TTL/LVCMOS	1			μA
		5-V tolerant	20			
		D0 – D3, CTL1, CTL2	20			
I_{OZ} High-impedance -state output current [¶]	$V_O = V_{CC}$ or GND	TTL/LVCMOS	± 20			μA
		5-V tolerant	± 20			

[†] This test condition is for terminals D0 – D3, CTL0, CTL1, CREQ, and CONTENDER

[‡] This test condition is for terminals DATA0 – DATA31, CA, INIT, CYCLEOUT, GRFEMP, CYDNE, CYST, NTOUT, POWERON, and LREQ.

[§] This specification only applies when pull up and pull down terminator is turned off.

[¶] Three-state output must be in high-impedance mode.

5.4 Host-Interface Timing Requirements, $T_A = 25^\circ\text{C}$ (See Note 3)

PARAMETER	MIN	MAX	UNIT
t_{c1} Cycle time, BCLK (see Figure 6-1)	20	111	ns
$t_{w1(H)}$ Pulse duration, BCLK high (see Figure 6-1)	10		ns
$t_{w1(L)}$ Pulse duration, BCLK low (see Figure 6-1)	10		ns
t_{su1} Setup time, DATA0 – DATA31 valid before BCLK \uparrow (see Figures 6-2, 6-4, 6-6)	4		ns
t_{h1} Hold time, DATA0 – DATA31 invalid after BCLK \uparrow (see Figures 6-2, 6-4, 6-6)	2		ns
t_{su2} Setup time, ADDR0 – ADDR7 valid before BCLK \uparrow (see Figures 6-2, 6-3, 6-4)	8		ns
t_{h2} Hold time, ADDR0 – ADDR7 invalid after BCLK \uparrow (see Figures 6-2, 6-3, 6-4)	2		ns
t_{su3} Setup time, \overline{CS} before BCLK \uparrow (see Figures 6-2, 6-3, 6-4)	8		ns
t_{h3} Hold time, \overline{CS} after BCLK \uparrow (see Figures 6-2, 6-3, 6-4)	2		ns
t_{su4} Setup time, \overline{WR} valid before BCLK \uparrow (see Figures 6-2, 6-3, 6-4)	8		ns
t_{h4} Hold time, \overline{WR} invalid after BCLK \uparrow (see Figures 6-2, 6-3, 6-4)	2		ns

NOTE 3: These parameters are not production tested.

5.5 Host-Interface Switching Characteristics Over Operating Free-Air Temperature Range, $C_L = 45$ pF (unless otherwise noted)

PARAMETER	MIN	MAX	UNIT
t_{d1} Delay time, BCLK \uparrow to \overline{CA} \downarrow (see Figures 6-2, 6-3, 6-5, 6-6, 6-7)	2.5	8	ns
t_{d2} Delay time, BCLK \uparrow to \overline{CA} \uparrow (see Figures 6-2, 6-3, 6-5, 6-6, 6-7)	2.5	8	ns
t_{d3} Delay time, BCLK \uparrow to DATA0 – DATA31 valid (see Figures 6-3, 6-4, 6-5, 6-7 and Note 3)	2.5	10	ns
t_{d4} Delay time, BCLK \uparrow to DATA0 – DATA31 invalid (see Figures 6-3, 6-4, 6-5, 6-7 and Note 3)	2.5	10	ns

NOTE 3: These parameters are not production tested.

5.6 Phy-Interface Timing Requirements Over Operating Free-Air Temperature Range (See Note 3)

PARAMETER	MIN	MAX	UNIT
t_{c2} Cycle time, SCLK (see Figure 6-8)	20.347	20.343	ns
$t_{w2(H)}$ Pulse duration, SCLK high (see Figure 6-8)	9		ns
$t_{w2(L)}$ Pulse duration, SCLK low (see Figure 6-8)	9		ns
t_{su5} Setup time, D0 – D7 valid before SCLK \uparrow (see Figure 6-10)	6		ns
t_{h5} Hold time, D0 – D7 invalid after SCLK \uparrow (see Figure 6-10)	1		ns
t_{su6} Setup time, CTL0 – CTL1 valid before SCLK \uparrow (see Figure 6-10)	6		ns
t_{h6} Hold time, CTL0 – CTL1 invalid after SCLK \uparrow (see Figure 6-10)	1		ns

NOTE 3: These parameters are not production tested.

5.7 Phy-Interface Switching Characteristics Over Operating Free-Air Temperature Range, $C_L = 45$ pF (unless otherwise noted) (See Note 3)

PARAMETER	MIN	MAX	UNIT
t_{d5} Delay time, SCLK \uparrow to D0 – D7 valid (see Figure 6–9)	3	11	ns
t_{d6} Delay time, SCLK \uparrow to D0 – D7 $\uparrow\downarrow$ (see Figure 6–9)	3	11	ns
t_{d7} Delay time, SCLK \uparrow to D0 – D7 invalid (see Figure 6–9)	3	11	ns
t_{d8} Delay time, SCLK \uparrow to CTL0 – CTL1 valid (see Figure 6–9)	3	11	ns
t_{d9} Delay time, SCLK \uparrow to CTL0 – CTL1 $\uparrow\downarrow$ (see Figure 6–9)	3	11	ns
t_{d10} Delay time, SCLK \uparrow to CTL0 – CTL1 invalid (see Figure 6–9)	3	11	ns
t_{d11} Delay time, SCLK \uparrow to LREQ $\uparrow\downarrow$ (see Figure 6–11)	3	11	ns

NOTE 3: These parameters are not production tested.

5.8 Miscellaneous Timing Requirements Over Operating Free-Air Temperature Range (see Figure 6–13 and Note 3)

PARAMETER	MIN	MAX	UNIT
t_{c3} Cycle time, CYCLEIN (see Figure 6–13)	124.99	125.01	μ s
$t_{w3(H)}$ Pulse duration, CYCLEIN \uparrow (see Figure 6–13)	62		μ s
$t_{w3(L)}$ Pulse duration, CYCLEIN \downarrow (see Figure 6–13)	62		μ s

NOTE 3: These parameters are not production tested.

5.9 Miscellaneous Signal Switching Characteristics Over Operating Free-Air Temperature Range (See Note 3)

PARAMETER	MIN	MAX	UNIT
t_{d12} Delay time, SCLK \uparrow to $\overline{INT}\downarrow$ (see Figure 6–12)	4	18	ns
t_{d13} Delay time, SCLK \uparrow to $\overline{INT}\uparrow$ (see Figure 6–12)	4	18	ns
t_{d14} Delay time, SCLK \uparrow to CYCLEOUT \uparrow (see Figure 6–14)	4	16	ns
t_{d15} Delay time, SCLK \uparrow to CYCLEOUT \downarrow (see Figure 6–14)	4	16	ns

NOTE 3: These parameters are not production tested.

6 Parameter Measurement Information

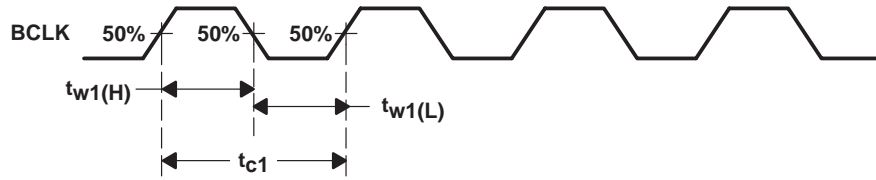
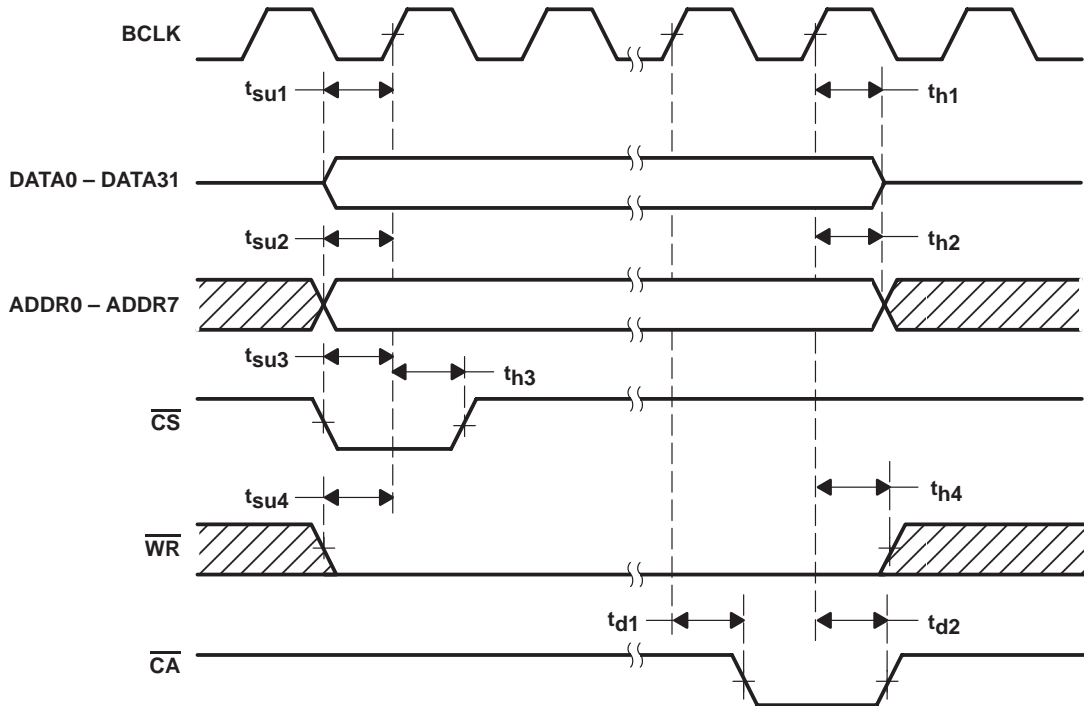
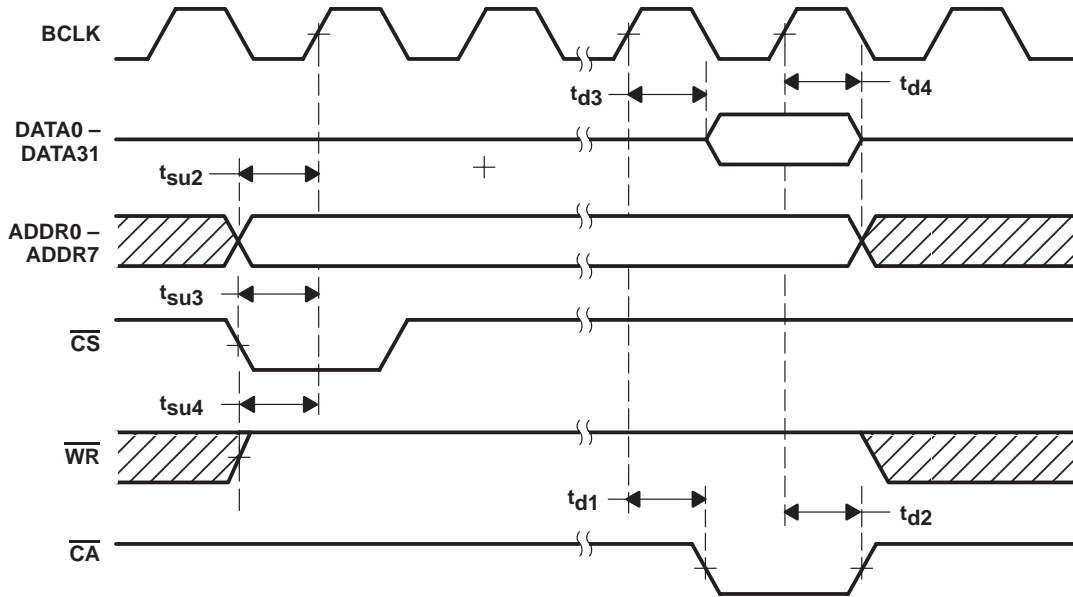


Figure 6-1. BCLK Waveform



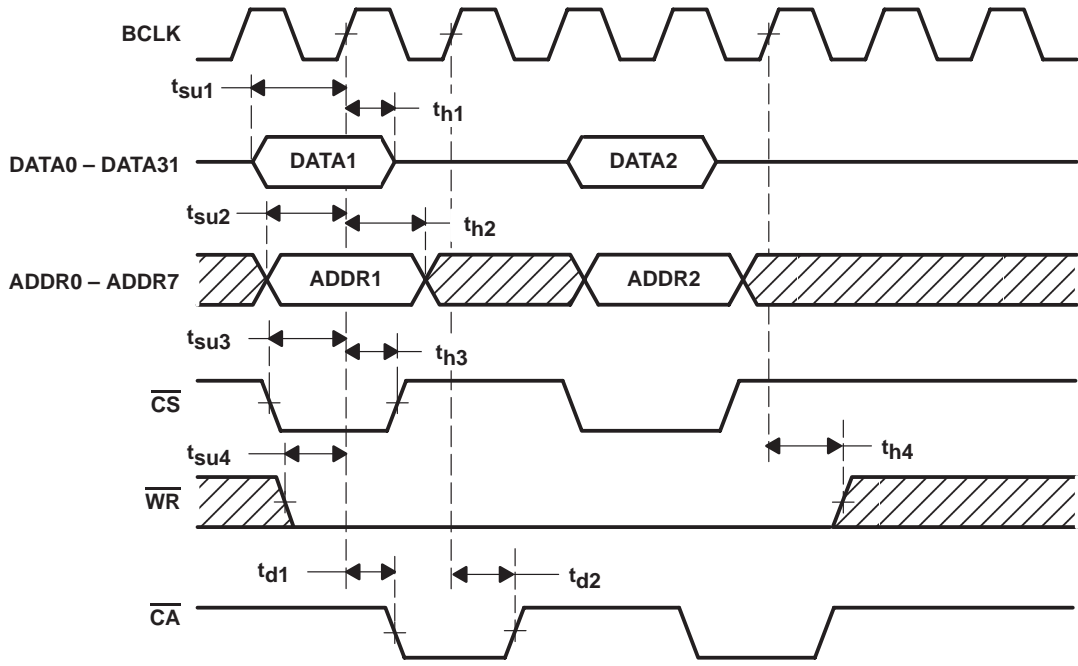
NOTE A. Following a \overline{CS} assertion, there may be a maximum of 9 rising edges of BCLK before a \overline{CA} is returned. \overline{CA} must be returned before another \overline{CS} may be asserted.

Figure 6-2. Host-Interface Write-Cycle Waveforms (Address: 00h - 2Ch)



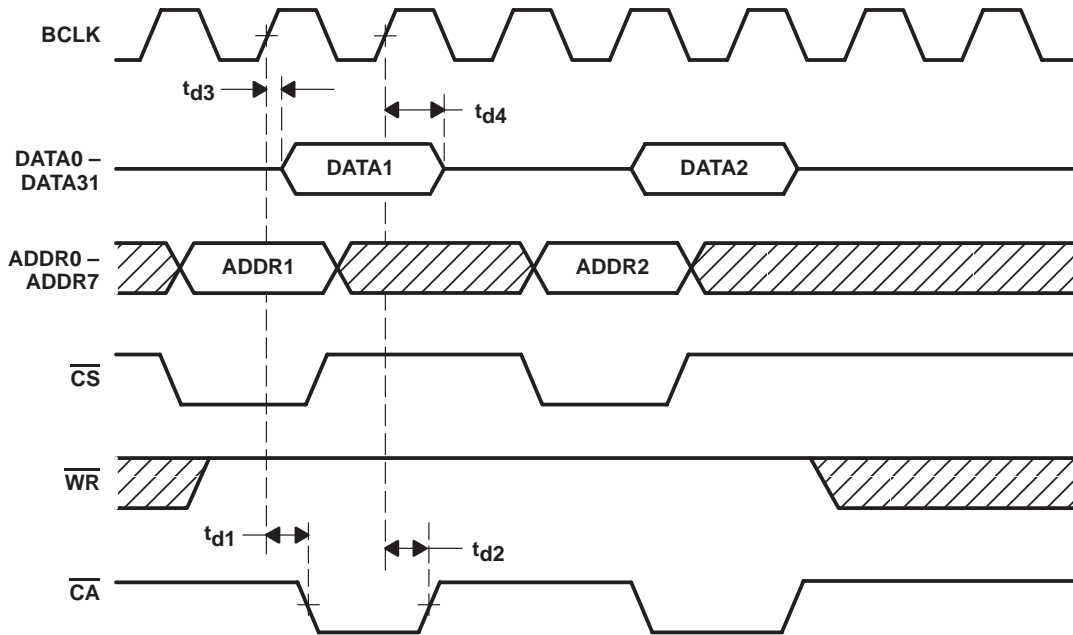
NOTE A. Following a \overline{CS} assertion, there may be a maximum of 9 rising edges of BCLK before a \overline{CA} is returned. \overline{CA} must be returned before another \overline{CS} may be asserted.

Figure 6-3. Host-Interface Read-Cycle Waveforms (Address: 00h – 2Ch)



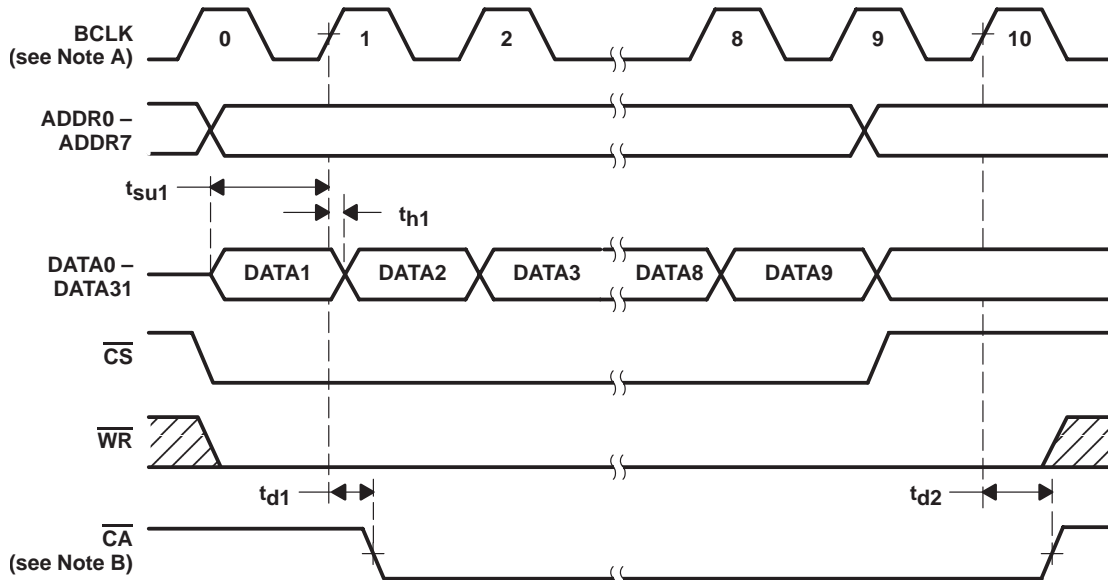
NOTE A. There must be a minimum of 3 rising edges of BCLK between assertions of \overline{CS} .

Figure 6-4. Host-Interface Quick Write-Cycle Waveforms (ADDR0 – ADDR7 ≥ 30h)



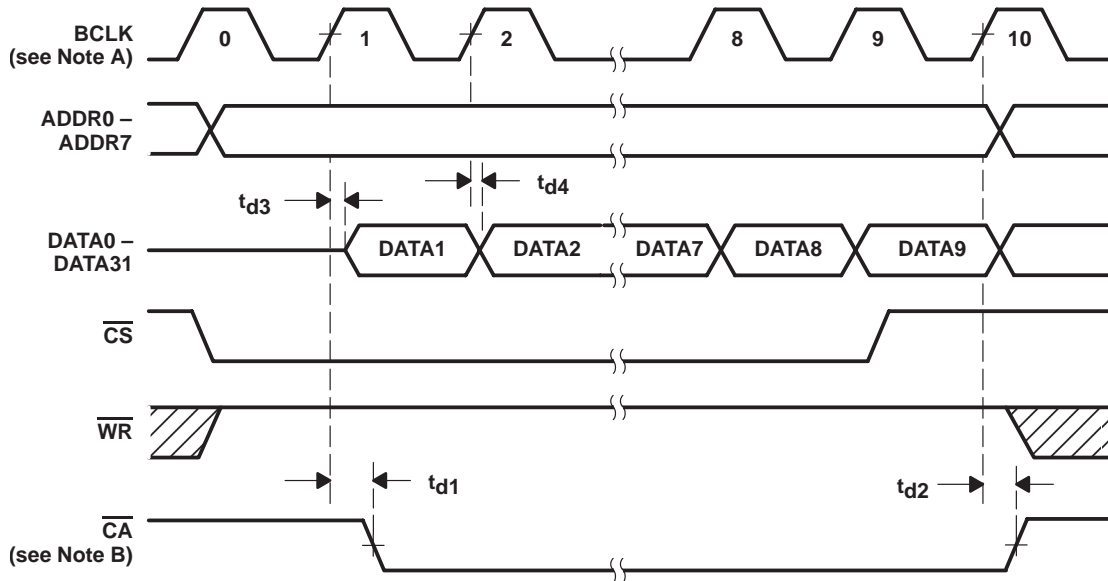
NOTE A. There must be a minimum of 3 rising edges of BCLK between assertions of \overline{CS} .

Figure 6–5. Host-Interface Quick Read-Cycle Waveforms (ADDR0 – ADDR7 \geq 30h)



- NOTES: A. At the nth BCLK rising edge, DATA_n is written into the FIFO.
 B. CA is one cycle delay from respective CS.

Figure 6-6. Burst Write Waveforms



- NOTES: A. At the nth BCLK rising edge, host bus should latch DATA_n.
 B. CA is one cycle delay from respective CS.
 C. These waveforms only apply to address C0h.

Figure 6-7. Burst Read Waveforms

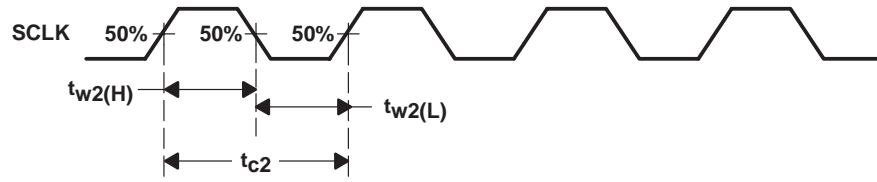


Figure 6–8. SCLK Waveform

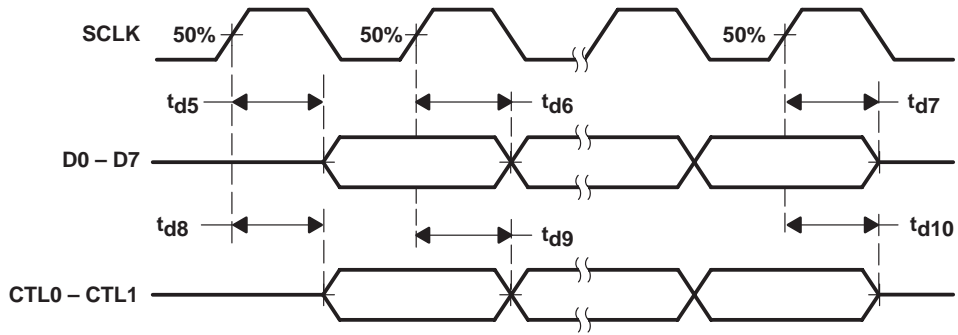


Figure 6–9. TSB12LV01A-to-Phy-Layer Transfer Waveforms

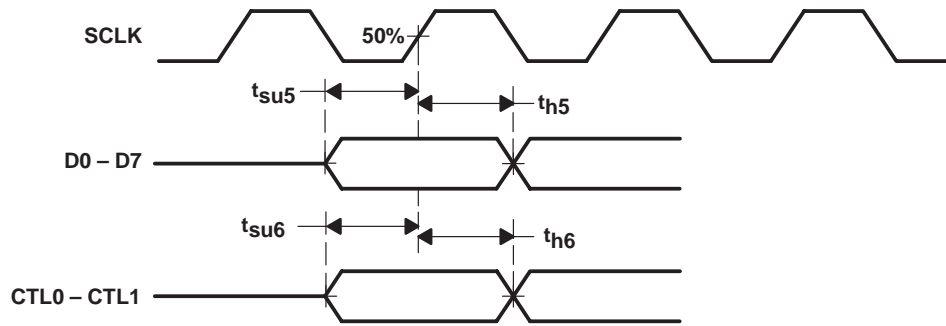


Figure 6-10. Phy Layer-to-TSB12LV01A Transfer Waveforms

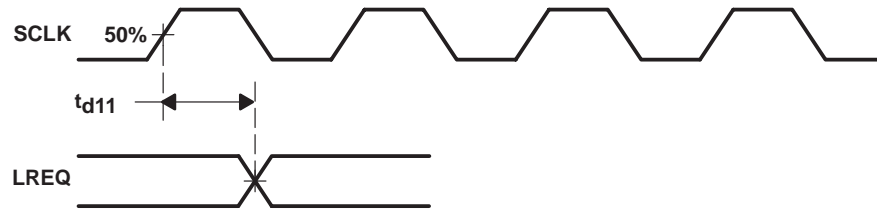


Figure 6-11. TSB12LV01A Link-Request-to-Phy-Layer Waveforms

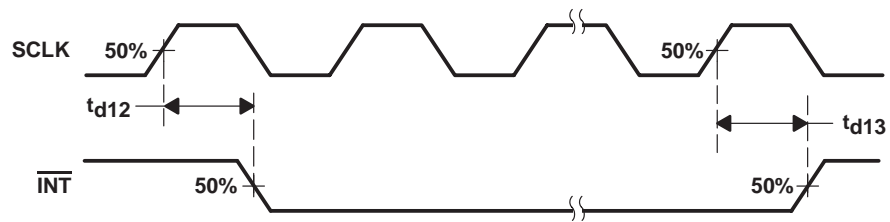


Figure 6-12. Interrupt Waveform

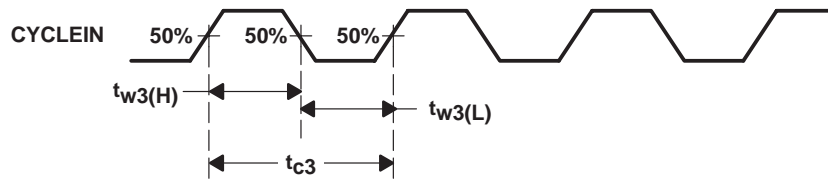


Figure 6-13. CYCLEIN Waveform

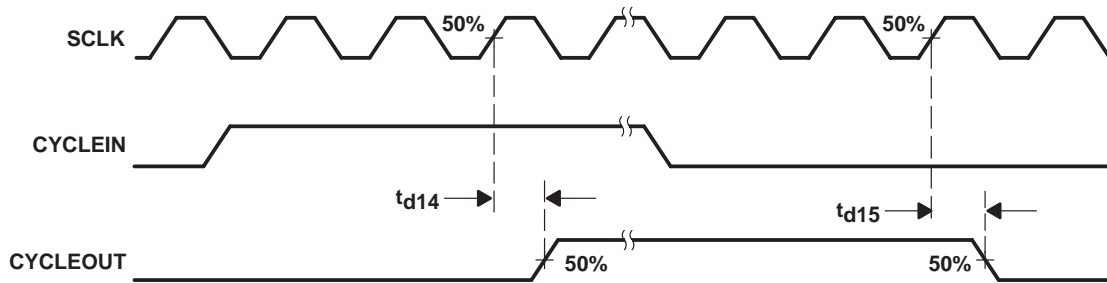


Figure 6-14. CYCLEIN and CYCLEOUT Waveforms

7 TSB12LV01A to 1394 Phy Interface Specification

7.1 Introduction

This chapter provides an overview of a TSB12LV01A to the phy interface. The information that follows can be used as a guide through the process of connecting the TSB12LV01A to a 1394 physical-layer device. The part numbers referenced, the TSB41LV03 and the TSB12LV01A, represent the Texas Instruments implementation of the phy (TSB41LV03) and link (TSB12LV01A) layers of the IEEE 1394-1995 standard.

The specific details of how the TSB41LV03 device operates are not discussed in this document. Only those parts that relate to the TSB12LV01A phy-link interface are mentioned.

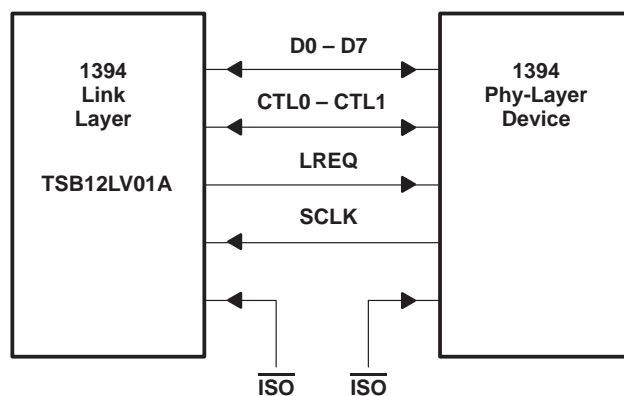
7.2 Assumptions

The TSB12LV01A is capable of supporting 100 Mb/s, 200 Mb/s, and 400 Mb/s phy-layer devices. For that reason, this document describes an interface to a 400-Mb/s (actually 393.216-Mb/s) device. To support lower-speed phy layers, adjust the width of the data bus by two terminals per 100 Mb/s. For example, for 100-Mb/s, 200-Mb/s, and 400-Mb/s devices, the data bus is 2, 4, and 8 bits wide respectively. The width of the CTL bus and the clock rate between the devices, however, does not change regardless of the transmission speed that is used.

Finally, the 1394 phy layer has control of all bidirectional terminals that run between the phy layer and TSB12LV01A. The TSB12LV01A can drive these terminals only after it has been given permission by the phy layer. A dedicated request terminal (LREQ) is used by the TSB12LV01A for any activity that the link wishes to initiate.

7.3 Block Diagram

The functional block diagram of the TSB12LV01A to phy layer is shown in Figure 7–1.



NOTE A: See Table 2–2 for signal definition.

Figure 7–1. Functional Block Diagram of the TSB12LV01A to Phy Layer

7.4 Operational Overview

The four operations that can occur in the phy-link interface are request, status, transmit, and receive. With the exception of the request operation, all actions are initiated by the phy layer.

The CTL0 – CTL1 bus is encoded as shown in the following sections.

7.4.1 Phy Interface Has Control of the Bus

Table 7–1. Phy Interface Control of Bus Functions

CTL0,CTL1	NAME	DESCRIPTION OF ACTIVITY
00	Idle	No activity is occurring (this is the default mode).
01	Status	Status information is being sent from the phy layer to the TSB12LV01A.
10	Receive	An incoming packet is being sent from the phy layer to the TSB12LV01A.
11	Transmit	The TSB12LV01A is given control of the bus to send an outgoing packet.

7.4.2 TSB12LV01A Has Control of the Bus

The TSB12LV01A has control of the bus after receiving permission from the phy layer.

Table 7–2. TSB12LV01A Control of Bus Functions

CTL0, CTL1	NAME	DESCRIPTION OF ACTIVITY
00	Idle	The TSB12LV01A releases the bus (transmission has been completed).
01	Hold	The TSB12LV01A is holding the bus while data is being prepared for transmission, or the TSB12LV01A wants to send another packet without arbitration.
10	Transmit	An outgoing packet is being sent from the TSB12LV01A to phy layer.
11	Reserved	None

7.5 Request

A serial stream of information is sent across the LREQ terminal whenever the TSB12LV01A needs to request the bus or access a register that is located in the phy layer. The size of the stream varies depending on whether the transfer is a bus request, a read command, or a write command. Regardless of the type of transfer, a start bit of 1 is required at the beginning of the stream and a stop bit of 0 is required at the end of the stream.

Table 7–3. Request Functions

NUMBER of BITS	NAME
7	Bus Request
9	Read Register Request
17	Write Register Request

7.5.1 LREQ Transfer

The definition of the bits in the three different types of transfers is shown in Table 7–4.

7.5.1.1 TSB12LV01A Bus Request

Table 7–4. Bus-Request Functions (Length of Stream: 7 Bits)

BIT(S)	NAME	DESCRIPTION
0	Start bit	Start bit indicates the beginning of the transfer (always set).
1–3	Request type	Request type indicates the type of bus request (see Table 7–7 for the encoding of this field).
4–5	Request speed	Request speed indicates the speed at which the phy interface sends the packet for this particular request (see Table 7–8 for the encoding of this field).
6	Stop bit	Stop bit indicates the end of the transfer (always cleared).

7.5.1.2 TSB12LV01A Read-Register Request

Table 7-5. Read-Register Request Functions (Length of Stream: 9 Bits)

BIT(S)	NAME	DESCRIPTION
0	Start bit	Start bit indicates the beginning of the transfer (always set).
1-3	Request type	Request type indicates the type of request function (see Table 7-7 for the encoding of this field).
4-7	Address	These bits contain the address of the phy register to be read.
8	Stop bit	Stop bit indicates the end of the transfer (always cleared).

7.5.1.3 TSB12LV01A Write-Register Request

Table 7-6. Write-Register Request (Length of Stream: 17 Bits)

BIT(S)	NAME	DESCRIPTION
0	Start bit	Start bit indicates the beginning of the transfer (always set).
1-3	Request type	Request type indicates the type of request (see Table 7-7 for the encoding of this field).
4-7	Address	These bits contain the address of the phy register to be written to.
8-15	Data	These bits contain the data that is to be written to the specified register address.
16	Stop bit	Stop bit indicates the end of the transfer (always cleared).

7.5.1.4 Request-Type Field for TSB12LV01A Request

Table 7-7. TSB12LV01A Request Functions

LREQ1 – LREQ3	NAME	DESCRIPTION
000	TakeBus	Immediate request. Upon detection of an idle, take control of the bus immediately (no arbitration) for asynchronous packet ACK response.
001	IsoReq	Isochronous request. IsoReq arbitrates for control of the bus after an isochronous gap.
010	PriReq	Priority request. PriReq arbitrates for control of the bus after a fair gap and ignores the fair protocol.
011	FairReq	Fair request. FairReq arbitrates for control of the bus after a fair gap and uses the fair protocol.
100	RdReg	Read request. RdReg returns the specified register contents through a status transfer.
101	WrReg	Write request. WrReg writes to the specified register.
110, 111	Reserved	Reserved

7.5.1.5 Request-Speed Field for TSB12LV01A Request

Table 7-8. TSB12LV01A Request-Speed Functions

LREQ4, LREQ5	DATA RATE
00	100 Mbits/s
01	200 Mbits/s
10	400 Mbits/s
11	Reserved

7.5.2 Bus Request

For fair or priority access, the TSB12LV01A requests control of the bus at least one clock after the TSB12LV01A phy interface becomes idle. CTL0 – CTL1 = 00 indicates the physical layer is in an idle state. If the TSB12LV01A senses that CTL0 – CTL1 = 10 (receive), then it knows that its request has been lost. This is true any time during or after the TSB12LV01A sends the bus request transfer. Additionally, the phy interface ignores any fair or priority requests when it asserts the receive state while the TSB12LV01A is requesting the bus. The link then reissues the request one clock after the next interface idle.

The cycle master uses a priority request to send a cycle-start message. After receiving a cycle start, the TSB12LV01A can issue an isochronous bus request. When arbitration is won, the TSB12LV01A proceeds with the isochronous transfer of data. The isochronous request is cleared in the phy interface once the TSB12LV01A sends another type of request or when the isochronous transfer has been completed.

The TakeBus request is issued when the TSB12LV01A needs to send an acknowledgment after reception of an asynchronous packet addressed to it. This request must be issued during packet reception. This is done to minimize the delay times that a phy interface would have to wait between the end of a packet reception and the transmittal of an acknowledgment. As soon as the packet ends, the phy interface immediately grants the bus access to the TSB12LV01A. The TSB12LV01A sends an acknowledgment to the sender unless the header CRC of the packet turns out to be invalid. In this case, the TSB12LV01A releases the bus immediately; it is not allowed to send another type of packet on this grant. To ensure this, the TSB12LV01A is forced to wait 160 ns after the end of the packet is received. The phy interface then gains control of the bus. The bus is then released and allowed to proceed with another request.

Although highly improbable, it is conceivable that two separate nodes believe that an incoming packet is intended for them. The nodes then issue a TakeBus request before checking the CRC of the packet. Since both phys seize control of the bus at the same time, a temporary, localized collision of the bus occurs somewhere between the competing nodes. This collision would be interpreted by the other nodes on the network as being a ZZ line state, not a bus reset. As soon as the two nodes check the CRC, the mistaken node drops its request and the false line state is removed. The only side effect is the loss of the intended acknowledgment packet (this is handled by the higher layer protocol).

7.5.3 Read/Write Requests

When the TSB12LV01A requests to read the specified register contents, the phy interface sends the contents of the register to the TSB12LV01A through a status transfer. When an incoming packet is received while the phy interface is transferring status information to the TSB12LV01A, the phy interface continues to attempt to transfer the contents of the register until it is successful.

For write requests, the phy interface loads the data field into the appropriately addressed register as soon as the transfer has been completed. The TSB12LV01A is allowed to request read or write operations at any time.

NOTE:

See Section 7.6, for a more detailed description of the status transfer.

7.6 Status

A status transfer is initiated by the phy interface when it has some status information to transfer to the TSB12LV01A. The transfer is initiated by asserting the following: CTL0 – CTL1 = 01 and D0 – D1s used to transmit the status data; see Table 7–9 for status-request functions. D2 – D7 are not used for status transfers.

The status transfer can be interrupted by an incoming packet from another node. When this occurs, the phy interface attempts to resend the status information after the packet has been acted upon. The phy interface continues to attempt to complete the transfer until the information has been successfully transmitted.

NOTE:

There must be at least one idle cycle between consecutive status transfers.

7.6.1 Status Request

The definition of the bits in the status transfer is shown in Table 7–9.

Table 7–9. Status-Request Functions (Length of Stream: 16 Bits)

BIT(s)	NAME	DESCRIPTION
0	Arbitration reset gap	The arbitration-reset gap bit indicates that the phy interface has detected that the bus has been idle for an arbitration reset gap time (this time is defined in the IEEE 1394-1995 standard). This bit is used by the TSB12LV01A in its busy/retry state machine.
1	Fair gap	The fair-gap bit indicates that the phy interface has detected that the bus has been idle for a fair-gap time (this time is defined in the IEEE 1394-1995 standard). This bit is used by the TSB12LV01A to detect the completion of an isochronous cycle.
2	Bus reset	The bus reset bit indicates that the phy interface has entered the bus reset state.
3	phy interrupt	The phy interrupt bit indicates that the phy interface is requesting an interrupt to the host.
4–7	Address	The address bits hold the address of the phy register whose contents are transferred to the TSB12LV01A.
8–15	Data	The data bits hold the data that is to be sent to the TSB12LV01A.

Normally, the phy interface sends only the first four bits of data to the TSB12LV01A. These bits are used by the TSB12LV01A state machine. However, if the TSB12LV01A initiates a read request (through a request transfer), then the phy interface sends the entire status packet to the TSB12LV01A. Additionally, the phy interface sends the contents of the register to the TSB12LV01A when it has some important information to pass on. Currently, the only condition where this occurs is after the self-identification process when the phy interface needs to inform the TSB12LV01A of its new node address (physical ID register).

There may be times when the phy interface wants to start a second status transfer. The phy interface first has to wait at least one clock cycle with the CTL lines idle before it can begin a second transfer.

7.6.2 Transmit

When the TSB12LV01A wants to transmit information, it first requests access to the bus through an LREQ signal. Once the phy interface receives this request, it arbitrates to gain control of the bus. When the phy interface wins ownership of the serial bus, it grants the bus to the TSB12LV01A by asserting the transmit state on the CTL terminals for at least one SCLK cycle. The TSB12LV01A takes control of the bus by asserting either hold or transmit on the CTL lines. Hold is used by the TSB12LV01A to keep control of the bus when it needs some time to prepare the data for transmission. The phy interface keeps control of the bus for the TSB12LV01A by asserting a data-on state on the bus. It is not necessary for the TSB12LV01A to use hold when it is ready to transmit as soon as bus ownership is granted.

When the TSB12LV01A is prepared to send data, it asserts transmit on the CTL lines as well as sends the first bits of the packet on the D0 – D7 lines (assuming 400 Mb/s). The transmit state is held on the CTL terminals until the last bits of data have been sent. The TSB12LV01A then asserts idle on the CTL lines for one clock cycle after which it releases control of the interface.

However, there are times when the TSB12LV01A needs to send another packet without releasing the bus. For example, the TSB12LV01A may want to send consecutive isochronous packets or it may want to attach a response to an acknowledgment. To do this, the TSB12LV01A asserts hold instead of idle when the first packet of data has been completely transmitted. Hold, in this case, informs the phy interface that the TSB12LV01A needs to send another packet without releasing control of the bus. The phy interface then waits a set amount of time before asserting transmit. The TSB12LV01A can then proceed with the transmittal of the second packet. After all data has been transmitted and the TSB12LV01A has asserted idle on the CTL terminals, the phy interface asserts its own idle state on the CTL lines. When sending multiple packets in this fashion, it is required that all data be transmitted at the same speed. This is required because the transmission speed is set during arbitration, and, since the arbitration step is skipped, there is no way of informing the network of a change in speed.

7.6.3 Receive

When data is received by the phy interface from the serial bus, it transfers the data to the TSB12LV01A for further processing. The phy interface asserts receive on the CTL lines and is set to 1 on each D terminal. The phy interface indicates the start of the packet by placing the speed code on the data bus (see the following note). The phy interface then proceeds with the transmittal of the packet to the TSB12LV01A on the D lines, while still keeping the receive status on the CTL terminals. Once the packet has been completely transferred, the phy interface asserts idle on the CTL terminals that completes the receive operation.

NOTE:

The speed code sent is a phy-TSB12LV01A protocol and not included in the packets CRC calculation.

SPD = Speed code

D0 ≥ Dn = Packet data

Table 7–10. Speed Code for Receive

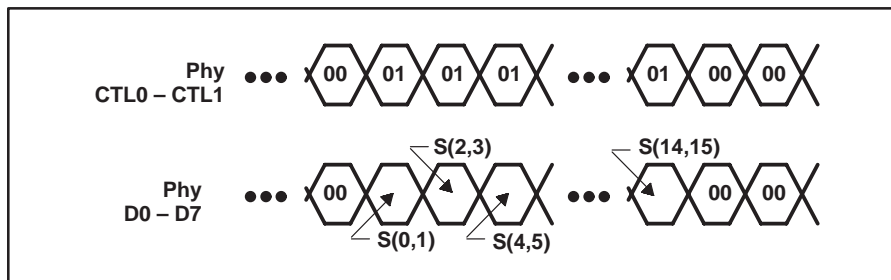
D0 – D7	DATA RATE
00xxxxx†	100 Mbits/s
0100xxxx†	200 Mbits/s
01010000	400 Mbits/s
11111111	Data-on indication

† The x means transmitted as 0 and ignored by phy layer.

7.7 TSB12LV01A to Phy Bus Timing

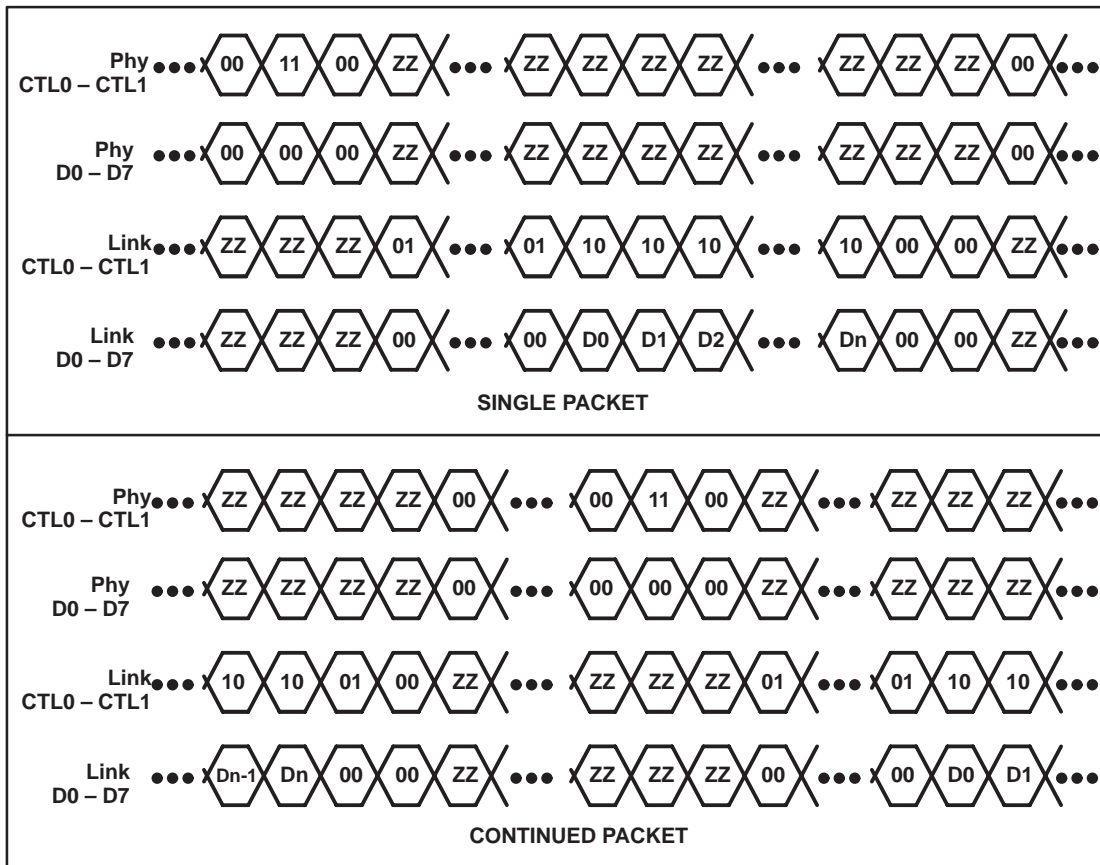


Figure 7–2. LREQ Timing



NOTE A: Each cell represents one SCLK sample time.

Figure 7–3. Status-Transfer Timing



NOTE A: ZZ = high-impedance state, D0 – Dn = packet data

Figure 7-4. Transmit Timing

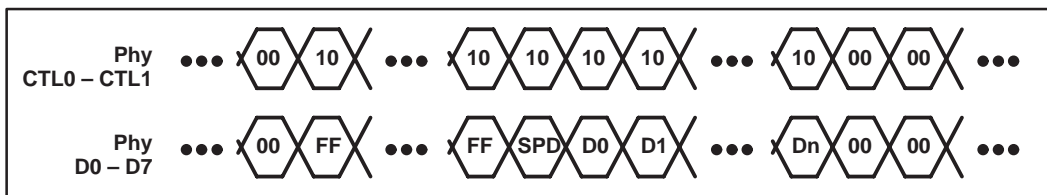
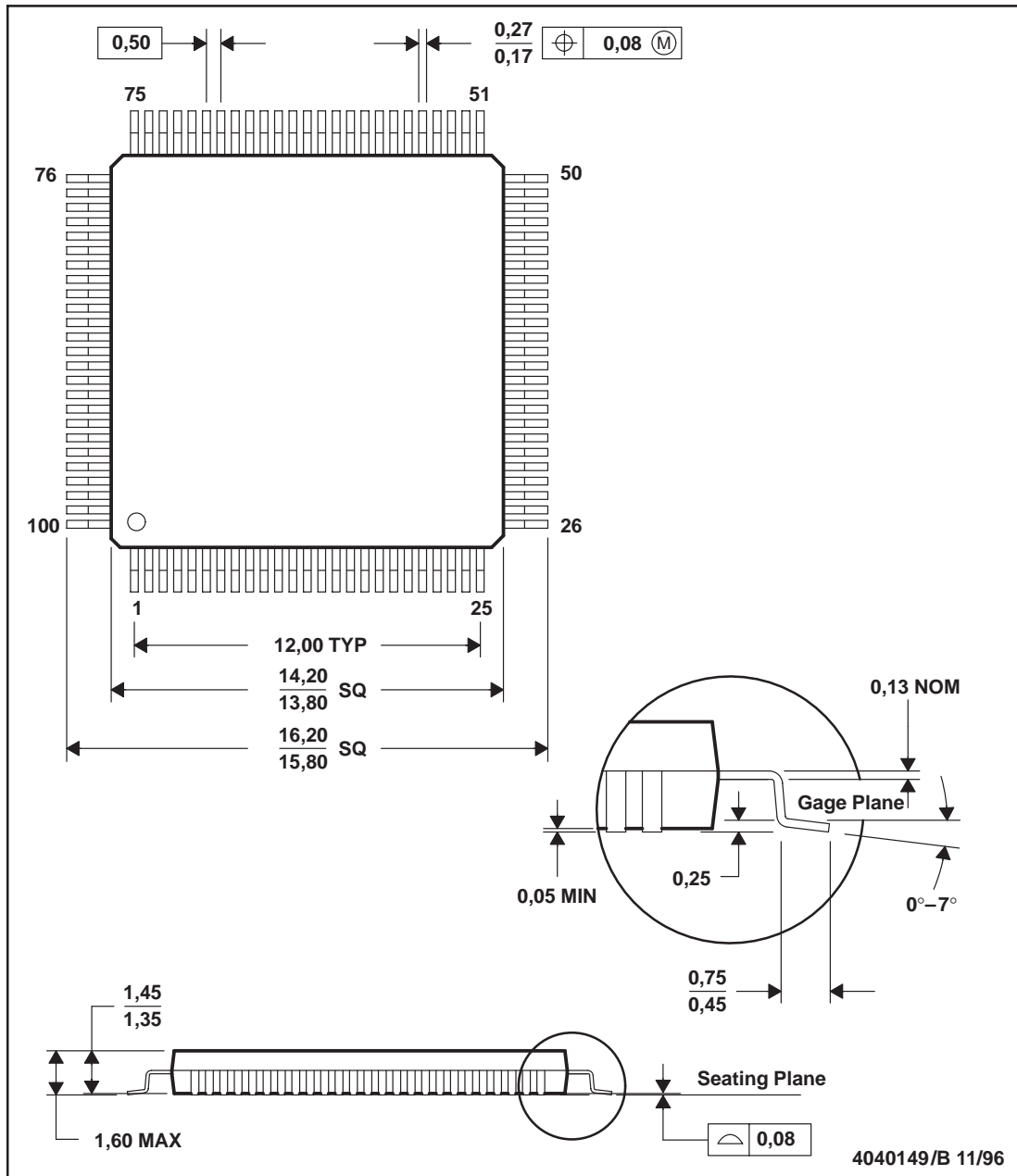


Figure 7-5. Receiver Timing

8 Mechanical Data

PZ (S-PQFP-G100)

PLASTIC QUAD FLATPACK



- NOTES:
- All linear dimensions are in millimeters.
 - This drawing is subject to change without notice.
 - Falls within JEDEC MS-026

IMPORTANT NOTICE

Texas Instruments and its subsidiaries (TI) reserve the right to make changes to their products or to discontinue any product or service without notice, and advise customers to obtain the latest version of relevant information to verify, before placing orders, that information being relied on is current and complete. All products are sold subject to the terms and conditions of sale supplied at the time of order acknowledgement, including those pertaining to warranty, patent infringement, and limitation of liability.

TI warrants performance of its semiconductor products to the specifications applicable at the time of sale in accordance with TI's standard warranty. Testing and other quality control techniques are utilized to the extent TI deems necessary to support this warranty. Specific testing of all parameters of each device is not necessarily performed, except those mandated by government requirements.

CERTAIN APPLICATIONS USING SEMICONDUCTOR PRODUCTS MAY INVOLVE POTENTIAL RISKS OF DEATH, PERSONAL INJURY, OR SEVERE PROPERTY OR ENVIRONMENTAL DAMAGE ("CRITICAL APPLICATIONS"). TI SEMICONDUCTOR PRODUCTS ARE NOT DESIGNED, AUTHORIZED, OR WARRANTED TO BE SUITABLE FOR USE IN LIFE-SUPPORT DEVICES OR SYSTEMS OR OTHER CRITICAL APPLICATIONS. INCLUSION OF TI PRODUCTS IN SUCH APPLICATIONS IS UNDERSTOOD TO BE FULLY AT THE CUSTOMER'S RISK.

In order to minimize risks associated with the customer's applications, adequate design and operating safeguards must be provided by the customer to minimize inherent or procedural hazards.

TI assumes no liability for applications assistance or customer product design. TI does not warrant or represent that any license, either express or implied, is granted under any patent right, copyright, mask work right, or other intellectual property right of TI covering or relating to any combination, machine, or process in which such semiconductor products or services might be or are used. TI's publication of information regarding any third party's products or services does not constitute TI's approval, warranty or endorsement thereof.