



### Features

- EDGE Large Signal Polar Modulation Compatible
- Three High Linearity, Low Loss, UMTS Switch Ports
- UMTS Port to Port Isolation >20dB
- Improved Power Flatness Into VSWR Through Integrated 2.5A Current Limiter
- Low Harmonics Into VSWR
- Excellent Switching Spectrum over Extreme Conditions
- GSM850 Max PAE 41%
- EGSM900 Max PAE 38%
- DCS1800 Max PAE 38%
- PCS1900 Max PAE 40%
- Internal DC Blocking in All RF Ports
- Drive Level 0dBm to 6dBm
- Proven *PowerStar*<sup>®</sup> Architecture

### Applications

- Battery Powered 3G Handsets
- GMSK/EDGE Large Signal Polar Modulation Transceivers
- GSM850/EGSM900/DCS/PCS Products
- Multislot Class 12 Products (4TX, 4RX Timeslots)

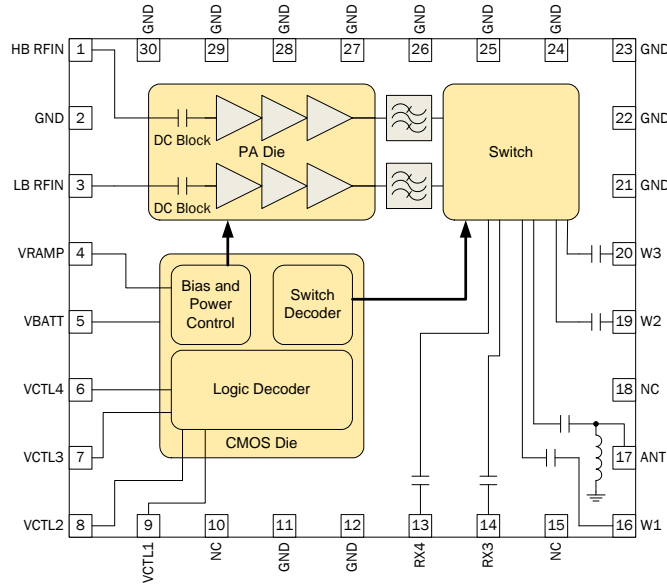

Functional Block Diagram

### Product Description

The RF3228 is a high-power, high-efficiency transmit module with integrated power control, an integrated pHEMT front end switch, and harmonic filtering functionality. This device is self-contained with 50Ω input and output terminals with no external matching circuits required. The device is designed for use as the last portion of the transmit chain in GMSK Polar EDGE architectures in GSM850, EGSM900, DCS, and PCS handheld digital cellular equipment where UMTS pass-through ports are needed. The RF3228 high performance transmit module offers mobile handset designers a compact, easy-to-use, front end solution for multi-mode, multi-band systems.

### Ordering Information

|                |   |
|----------------|---|
| RF3228         | Quad-Band GMSK Polar Edge TXM, 2 RX and 3 UMTS Switch Ports |
| RF3228SB       | 5-Piece Module Sample Pack                                  |
| RF3228PCBA-410 | Fully Assembled Evaluation Board                            |

### Optimum Technology Matching<sup>®</sup> Applied

- |  |                                      |  |                                   |
|--|--------------------------------------|--|-----------------------------------|
| <input checked="" type="checkbox"/> GaAs HBT | <input type="checkbox"/> SiGe BiCMOS | <input checked="" type="checkbox"/> GaAs pHEMT | <input type="checkbox"/> GaN HEMT |
| <input type="checkbox"/> GaAs MESFET         | <input type="checkbox"/> Si BiCMOS   | <input checked="" type="checkbox"/> Si CMOS    | <input type="checkbox"/> RF MEMS  |
| <input type="checkbox"/> InGaP HBT           | <input type="checkbox"/> SiGe HBT    | <input type="checkbox"/> Si BJT                | <input type="checkbox"/> LDMS     |

RF MICRO DEVICES®, RFMD®, Optimum Technology Matching®, Enabling Wireless Connectivity™, PowerStar®, POLARIS™ TOTAL RADIO™ and UltimateBlue™ are trademarks of RFMD, LLC. BLUETOOTH is a trademark owned by Bluetooth SIG, Inc., U.S.A. and licensed for use by RFMD. All other trade names, trademarks and registered trademarks are the property of their respective owners. ©2006, RF Micro Devices, Inc.

## Absolute Maximum Ratings

| Parameter   | Rating       | Unit |
|---|--------------|------|
| Supply Voltage in Standby Mode  | -0.5 to +6.0 | V    |
| Supply Voltage in Idle Mode   | -0.5 to +6.0 | V    |
| Supply Voltage in Operating Mode<br>(Operation time less than 100ms; $V_{RAMP} \leq 1.6V$ ) | -0.5 to +6.0 | V    |
| DC Continuous current during burst  | 2.8          | A    |
| VCTL 1 - 4  | -0.5 to +3.0 | V    |
| Power Control Voltage ( $V_{RAMP}$ )  | -0.5 to +1.8 | V    |
| Input RF Power  | +12          | dBm  |
| Duty Cycle with power reduction per 3GPP Power Profile 2                                    | 50           | %    |
| Output Load VSWR (See Ruggedness Specification)   | 20:1         |      |
| Operating Temperature   | -30 to +85   | °C   |
| Storage Temperature   | -55 to +150  | °C   |



**Caution!** ESD sensitive device.

Exceeding any one or a combination of the Absolute Maximum Rating conditions may cause permanent damage to the device. Extended application of Absolute Maximum Rating conditions to the device may reduce device reliability. Specified typical performance or functional operation of the device under Absolute Maximum Rating conditions is not implied.

RoHS status based on EU Directive 2002/95/EC (at time of this document revision).

The information in this publication is believed to be accurate and reliable. However, no responsibility is assumed by RF Micro Devices, Inc. ("RFMD") for its use, nor for any infringement of patents, or other rights of third parties, resulting from its use. No license is granted by implication or otherwise under any patent or patent rights of RFMD. RFMD reserves the right to change component circuitry, recommended application circuitry and specifications at any time without prior notice.

| Parameter                           | Specification |      |      | Unit     | Condition  |
|-------------------------------------|---------------|------|------|----------|--|
|                                     | Min.          | Typ. | Max. |          |  |
| <b>General Operating Conditions</b> |               |      |      |          |  |
| Operating Temperature               | -20           | 25   | 85   | °C       | Specified operating range.   |
| $V_{BATT}$ Supply Voltage           | 3.2           | 3.6  | 4.6  | V        | Specified operating range.   |
|                                     | 3             |      | 4.8  | V        | Functional operating range.  |
| $V_{BATT}$ Supply Current           |               |      |      |          |  |
| Off State                           |               | 0.1  | 10   | uA       | Mode=Standby   |
| Antenna Switch Active (RX path)     |               | 60   | 150  | uA       | Mode=RXn (n=3, 4)  |
| Antenna Switch Active (W path)      |               | 60   | 150  | uA       | Mode=Wn (n=1, 2, 3)  |
| Transmit Mode with Current Limit    |               | 2300 | 2600 | mA       | Mode=TX LB, TX HB  |
| $V_{RAMP}$ Input                    |               |      |      |          |  |
| GMSK Operation                      | 0.2           |      | 1.6  | V        | $V_{RAMP}$ voltage controls saturated power                          |
| EDGE Operation                      | 0.2           |      | 1.6  | V        | $V_{RAMP}$ voltage controls saturated power and amplitude modulation |
| Impedance                           | 50k $\Omega$  |      | 10pF |          | Worst Case is 50k $\Omega$ with 5pF                                  |
| VCTL 1-4                            |               |      |      |          | Logic control voltages   |
| Logic Low Voltage                   | 0             | 0    | 0.5  | V        |  |
| Logic High Voltage                  | 1.3           | 2.0  | 3.0  | V        |  |
| Logic High Current                  |               | 0.1  | 10   | uA       |  |
| RF Input and Output Impedance       |               | 50   |      | $\Omega$ | Pins 1, 3, 13, 14, 16, 17, 19, 20                                    |

**Module Control Logic**

| <b>Mode</b> | <b>VCTL1</b> | <b>VCTL2</b> | <b>VCTL3</b> | <b>VCTL4</b> |
|-------------|--------------|--------------|--------------|--------------|
| Standby     | 0            | 0            | 0            | 0            |
| TX LB       | 0            | 0            | 0            | 1            |
| TX HB       | 0            | 0            | 1            | 1            |
| RX3         | 1            | X            | 1            | 1            |
| RX4         | 1            | X            | 1            | 0            |
| W1          | 0            | 0            | 1            | 0            |
| W2          | 0            | 1            | 0            | 0            |
| W3          | 0            | 1            | 1            | 0            |

| Parameter  | Specification                                |      |      | Unit  | Condition   |
|--|--|------|------|-------|---|
|  | Min.   | Typ. | Max. |       |   |
| <b>GSM850 Band GMSK Parameters</b>                 |  |      |      |       | <b>Unless otherwise stated:</b><br>All unused RF ports terminated in 50Ω,<br>Input and Output=50Ω,<br>Temperature=25°C, V <sub>BATT</sub> =3.6V,<br>Mode=TX LB, GSM timeslots≤2,<br>P <sub>IN</sub> =3dBm, V <sub>RAMP</sub> =Max |
| Operating Frequency                                | 824  |      | 849  | MHz   |   |
| Input Power (P <sub>IN</sub> )                     | 0  | 3    | 6    | dBm   |   |
| Input VSWR   |  |      | 3:1  | Ratio | V <sub>RAMP</sub> =0.25V to 1.6V  |
| Maximum Output Power (Nominal)                     | 32.7   | 33.7 |      | dBm   | Temp=+25°C, V <sub>BATT</sub> =3.6V   |
| Maximum Output Power (Extreme)                     | 30.5   | 31.5 |      | dBm   | P <sub>IN</sub> =0dBm, Temp=+85°C, V <sub>BATT</sub> =3.2V  |
| Power Added Efficiency (Max Power)                 | 36   | 41   |      | %     |   |
| Power Added Efficiency (Rated Power)               | 32   | 37   |      | %     | P <sub>OUT</sub> =32.7 dBm  |
| Peak Supply Current (Rated Power)                  | 800  | 1400 | 1615 | mA    | P <sub>OUT</sub> =32.7 dBm  |
| Peak Supply Current (Low Power)                    | 70   | 120  | 160  | mA    | P <sub>OUT</sub> =5 dBm   |
| Receive Band Noise Power                           |  |      |      |       | P <sub>OUT</sub> ≤32.7 dBm, Bandwidth=100kHz  |
| 869MHz to 894MHz (CEL)                             |  | -88  | -82  | dBm   | 20MHz noise   |
| 1930MHz to 1990MHz (PCS)                           |  | -117 | -90  | dBm   | Out of band noise   |
| Harmonics  |  |      |      |       | V <sub>RAMP</sub> =V <sub>RAMPRP</sub>  |
| 2F <sub>0</sub>                                    |  | -40  | -33  | dBm   |   |
| 3F <sub>0</sub>                                    |  | -40  | -33  | dBm   |   |
| 4F <sub>0</sub> to 12.75GHz                        |  | -40  | -33  | dBm   |   |
| Stability Under Load Mismatch (Spurious Emissions) |  |      | -36  | dBm   | Output Load VSWR=15:1, All phase angles,<br>Temp=-20°C to +85°C, V <sub>BATT</sub> =3.2V to 4.6V,<br>V <sub>RAMP</sub> ≤V <sub>RAMPRP</sub>   |
| Ruggedness Under Load Mismatch                     | No damage or permanent degradation to device |      |      |       | Output Load VSWR=20:1, All phase angles,<br>Temp=-20°C to +85°C, V <sub>BATT</sub> =3.2V to 4.6V,<br>V <sub>RAMP</sub> ≤V <sub>RAMPRP</sub>   |
| Forward Isolation 1                                |  | -48  | -40  | dBm   | Mode=Standby, P <sub>IN</sub> =Max, V <sub>RAMP</sub> =Min  |
| Forward Isolation 2                                |  | -28  | -20  | dBm   | Mode=TX LB, P <sub>IN</sub> =Max, V <sub>RAMP</sub> =Min  |

Notes:

V<sub>RAMPRP</sub> is defined as the V<sub>RAMP</sub> voltage required to achieve 32.7dBm at V<sub>BATT</sub>=3.6V, Temperature=25°C, P<sub>IN</sub>=3dBm

| Parameter   | Specification |      |      | Unit  | Condition  |
|---|---------------|------|------|-------|--|
|   | Min.          | Typ. | Max. |       |  |
| <b>GSM850 Band 8PSK Parameters<br/>(Large Signal Polar)</b> |               |      |      |       | <b>Unless otherwise stated:</b><br>All unused RF ports terminated in 50Ω,<br>Input and Output=50Ω,<br>Temperature=25 °C, V <sub>BATT</sub> =3.6V,<br>Mode=TX LB, GSM timeslots≤2,<br>P <sub>IN</sub> =3dBm |
| Operating Frequency   | 824           |      | 849  | MHz   |  |
| Input Power (P <sub>IN</sub> )                              | 0             | 3    | 6    | dBm   |  |
| Input VSWR  |               |      | 3:1  | Ratio | V <sub>RAMP</sub> =0.25V to 1.6V   |
| Maximum 8PSK Average Output Power<br>(Nominal)              | 28            | 29   |      | dBm   | Temp=+25 °C, V <sub>BATT</sub> =3.6V   |
| Maximum 8PSK Average Output Power<br>(Extreme)              | 26            | 27   |      | dBm   | Temp=+85 °C, V <sub>BATT</sub> =3.2V   |
| PAE   | 18            | 20   |      | %     | P <sub>OUT</sub> =28dBm  |
| Peak Supply Current (Rated Power)                           | 500           | 830  | 980  | mA    | P <sub>OUT</sub> =28dBm  |
| Peak Supply Current (Low Power)                             | 70            | 120  | 160  | mA    | P <sub>OUT</sub> =5dBm   |
| V <sub>RAMP</sub> Power Control Range                       | 53            | 62   |      | dB    |  |
| V <sub>RAMP</sub> Loop Bandwidth                            | 2.5           | 10   |      | MHz   | 5 dBm ≤ P <sub>OUT</sub> ≤ Maximum 8PSK Average Power  |
| V <sub>RAMP</sub> Group Delay                               |               | 35   |      | ns    | 5 dBm ≤ P <sub>OUT</sub> ≤ Maximum 8PSK Average Power  |
| V <sub>RAMP</sub> Group Delay Variation                     | -20           | 0    | 20   | ns    | 5 dBm ≤ P <sub>OUT</sub> ≤ Maximum 8PSK Average Power  |

| Parameter  | Specification                                |      |      | Unit  | Condition   |
|--|--|------|------|-------|---|
|  | Min.   | Typ. | Max. |       |   |
| <b>GSM900 Band GMSK Parameters</b>                 |  |      |      |       | <b>Unless otherwise stated:</b><br>All unused RF ports terminated in 50Ω,<br>Input and Output=50Ω,<br>Temperature=25°C, V <sub>BATT</sub> =3.6V,<br>Mode=TX LB, GSM timeslots≤2,<br>P <sub>IN</sub> =3dBm, V <sub>RAMP</sub> =Max |
| Operating Frequency                                | 880  |      | 915  | MHz   |   |
| Input Power (P <sub>IN</sub> )                     | 0  | 3    | 6    | dBm   |   |
| Input VSWR   |  |      | 3:1  | Ratio | V <sub>RAMP</sub> =0.25V to 1.6V  |
| Maximum Output Power (Nominal)                     | 32.7   | 33.2 |      | dBm   | Temp=+25°C, V <sub>BATT</sub> =3.6V   |
| Maximum Output Power (Extreme)                     | 30.5   | 31.0 |      | dBm   | P <sub>IN</sub> =0dBm, Temp=+85°C, V <sub>BATT</sub> =3.2V  |
| Power Added Efficiency (Max Power)                 | 33   | 38   |      | %     |   |
| Power Added Efficiency (Rated Power)               | 32   | 36   |      | %     | P <sub>OUT</sub> =32.7 dBm  |
| Peak Supply Current (Rated Power)                  | 800  | 1435 | 1615 | mA    | P <sub>OUT</sub> =32.7 dBm  |
| Peak Supply Current (Low Power)                    | 70   | 120  | 160  | mA    | P <sub>OUT</sub> =5 dBm   |
| Receive Band Noise Power                           |  |      |      |       | P <sub>OUT</sub> ≤32.7 dBm, Bandwidth=100kHz  |
| 925 MHz to 935 MHz (EGSM)                          |  | -81  | -78  | dBm   | 10MHz noise   |
| 935 MHz to 960MHz (EGSM)                           |  | -89  | -83  | dBm   | 20MHz noise   |
| 1805 MHz to 1880MHz (DCS)                          |  | -117 | -90  | dBm   | Out of band noise.  |
| Harmonics  |  |      |      |       | V <sub>RAMP</sub> =V <sub>RAMPRP</sub>  |
| 2F <sub>0</sub>                                    |  | -40  | -33  | dBm   |   |
| 3F <sub>0</sub>                                    |  | -40  | -33  | dBm   |   |
| 4F <sub>0</sub> to 12.75GHz                        |  | -40  | -33  | dBm   |   |
| Stability Under Load Mismatch (Spurious Emissions) |  |      | -36  | dBm   | Output Load VSWR=15:1, All phase angles,<br>Temp=-20°C to +85°C, V <sub>BATT</sub> =3.2V to 4.6V,<br>V <sub>RAMP</sub> ≤V <sub>RAMPRP</sub>   |
| Ruggedness Under Load Mismatch                     | No damage or permanent degradation to device |      |      |       | Output Load VSWR=20:1, All phase angles,<br>Temp=-20°C to +85°C, V <sub>BATT</sub> =3.2V to 4.6V,<br>V <sub>RAMP</sub> ≤V <sub>RAMPRP</sub>   |
| Forward Isolation 1                                |  | -48  | -40  | dBm   | Mode=Standby, P <sub>IN</sub> =Max, V <sub>RAMP</sub> =Min  |
| Forward Isolation 2                                |  | -28  | -20  | dBm   | Mode=TX LB, P <sub>IN</sub> =Max, V <sub>RAMP</sub> =Min  |

Notes:

V<sub>RAMPRP</sub> is defined as the V<sub>RAMP</sub> voltage required to achieve 32.7 dBm at V<sub>BATT</sub>=3.6V, Temperature=25°C, P<sub>IN</sub>=3dBm

| Parameter   | Specification |      |      | Unit  | Condition  |
|---|---------------|------|------|-------|--|
|   | Min.          | Typ. | Max. |       |  |
| <b>GSM900 Band 8PSK Parameters<br/>(Large Signal Polar)</b> |               |      |      |       | <b>Unless otherwise stated:</b><br>All unused RF ports terminated in 50Ω,<br>Input and Output=50Ω,<br>Temperature=25 °C, V <sub>BATT</sub> =3.6V,<br>Mode=TX LB, GSM timeslots≤2,<br>P <sub>IN</sub> =3dBm |
| Operating Frequency   | 880           |      | 915  | MHz   |  |
| Input Power (P <sub>IN</sub> )                              | 0             | 3    | 6    | dBm   |  |
| Input VSWR  |               |      | 3:1  | Ratio | V <sub>RAMP</sub> =0.25V to 1.6V   |
| Maximum 8PSK Average Output Power<br>(Nominal)              | 28            | 29   |      | dBm   | Temp=+25 °C, V <sub>BATT</sub> =3.6V   |
| Maximum 8PSK Average Output Power<br>(Extreme)              | 26            | 27   |      | dBm   | Temp=+85 °C, V <sub>BATT</sub> =3.2V   |
| PAE   | 18            | 20   |      | %     | P <sub>OUT</sub> =28dBm  |
| Peak Supply Current (Rated Power)                           | 500           | 850  | 980  | mA    | P <sub>OUT</sub> =28dBm  |
| Peak Supply Current (Low Power)                             | 70            | 120  | 160  | mA    | P <sub>OUT</sub> =5dBm   |
| V <sub>RAMP</sub> Power Control Range                       | 53            | 62   |      | dB    |  |
| V <sub>RAMP</sub> Loop Bandwidth                            | 2.5           | 10   |      | MHz   | 5 dBm ≤ P <sub>OUT</sub> ≤ Maximum 8PSK Average Power  |
| V <sub>RAMP</sub> Group Delay                               |               | 35   |      | ns    | 5 dBm ≤ P <sub>OUT</sub> ≤ Maximum 8PSK Average Power  |
| V <sub>RAMP</sub> Group Delay Variation                     | -20           | 0    | 20   | ns    | 5 dBm ≤ P <sub>OUT</sub> ≤ Maximum 8PSK Average Power  |

| Parameter  | Specification                                |      |      | Unit  | Condition   |
|--|--|------|------|-------|---|
|  | Min.   | Typ. | Max. |       |   |
| <b>DCS1800 Band GMSK Parameters</b>                |  |      |      |       | <b>Unless otherwise stated:</b><br>All unused RF ports terminated in 50Ω,<br>Input and Output=50Ω,<br>Temperature=25°C, V <sub>BATT</sub> =3.6V,<br>Mode=TX HB, GSM timeslots≤2,<br>P <sub>IN</sub> =3dBm, V <sub>RAMP</sub> =Max |
| Operating Frequency                                | 1710   |      | 1785 | MHz   |   |
| Input Power (P <sub>IN</sub> )                     | 0  | 3    | 6    | dBm   |   |
| Input VSWR   |  |      | 3:1  | Ratio | V <sub>RAMP</sub> =0.25V to 1.6V  |
| Maximum Output Power (Nominal)                     | 30   | 31   |      | dBm   | Temp=+25°C, V <sub>BATT</sub> =3.6V   |
| Maximum Output Power (Extreme)                     | 27.5   | 29   |      | dBm   | P <sub>IN</sub> =0dBm, Temp=+85°C, V <sub>BATT</sub> =3.2V  |
| Power Added Efficiency (Max Power)                 | 33   | 38   |      | %     |   |
| Power Added Efficiency (Rated Power)               | 30   | 33   |      | %     | P <sub>OUT</sub> =30.0dBm   |
| Peak Supply Current (Rated Power)                  | 450  | 830  | 930  | mA    | P <sub>OUT</sub> =30.0dBm   |
| Peak Supply Current (Low Power)                    | 70   | 115  | 160  | mA    | P <sub>OUT</sub> =0dBm  |
| Receive Band Noise Power                           |  |      |      |       | P <sub>OUT</sub> ≤30.0dBm, Bandwidth=100kHz   |
| 925 MHz to 960MHz (EGSM)                           |  | -102 | -90  | dBm   | Out of band noise   |
| 1805 MHz to 1880MHz (DCS)                          |  | -90  | -78  | dBm   | 20MHz noise   |
| Harmonics  |  |      |      |       | V <sub>RAMP</sub> =V <sub>RAMPRP</sub>  |
| 2F <sub>0</sub>                                    |  | -40  | -33  | dBm   |   |
| 3F <sub>0</sub>                                    |  | -40  | -33  | dBm   |   |
| Other Harmonics, 4F <sub>0</sub> to 12.75GHz       |  | -40  | -31  | dBm   |   |
| Stability Under Load Mismatch (Spurious Emissions) |  |      | -36  | dBm   | Output Load VSWR=15:1, All phase angles,<br>Temp=-20°C to +85°C, V <sub>BATT</sub> =3.2V to 4.6V,<br>V <sub>RAMP</sub> ≤V <sub>RAMPRP</sub>   |
| Ruggedness Under Load Mismatch                     | No damage or permanent degradation to device |      |      |       | Output Load VSWR=20:1, All phase angles,<br>Temp=-20°C to +85°C, V <sub>BATT</sub> =3.2V to 4.6V,<br>V <sub>RAMP</sub> ≤V <sub>RAMPRP</sub>   |
| Forward Isolation 1                                |  | -58  | -40  | dBm   | Mode=Standby, P <sub>IN</sub> =Max, V <sub>RAMP</sub> =Min  |
| Forward Isolation 2                                |  | -25  | -20  | dBm   | Mode=TX HB, P <sub>IN</sub> =Max, V <sub>RAMP</sub> =Min  |

Notes:

V<sub>RAMPRP</sub> is defined as the V<sub>RAMP</sub> voltage required to achieve 30.0dBm at V<sub>BATT</sub>=3.6V, Temperature=25°C, P<sub>IN</sub>=3dBm

| Parameter  | Specification |      |      | Unit  | Condition  |
|--|---------------|------|------|-------|--|
|  | Min.          | Typ. | Max. |       |  |
| <b>DCS1800 Band 8PSK Parameters<br/>(Large Signal Polar)</b> |               |      |      |       | <b>Unless otherwise stated:</b><br>All unused RF ports terminated in 50Ω,<br>Input and Output=50Ω,<br>Temperature=25 °C, V <sub>BATT</sub> =3.6V,<br>Mode=TX HB, GSM timeslots≤2,<br>P <sub>IN</sub> =3dBm |
| Operating Frequency  | 1710          |      | 1785 | MHz   |  |
| Input Power (P <sub>IN</sub> )                               | 0             | 3    | 6    | dBm   |  |
| Input VSWR   |               |      | 3:1  | Ratio | V <sub>RAMP</sub> =0.25V to 1.6V   |
| Maximum 8PSK Average Output Power<br>(Nominal)               | 27            | 28   |      | dBm   | Temp=+25 °C, V <sub>BATT</sub> =3.6V   |
| Maximum 8PSK Average Output Power<br>(Extreme)               | 25            | 26   |      | dBm   | Temp=+85 °C, V <sub>BATT</sub> =3.2V   |
| PAE  | 20            | 23   |      | %     | P <sub>OUT</sub> =27dBm  |
| Peak Supply Current (Rated Power)                            | 350           | 600  | 700  | mA    | P <sub>OUT</sub> =27dBm  |
| Peak Supply Current (Low Power)                              | 70            | 115  | 160  | mA    | P <sub>OUT</sub> =0dBm   |
| V <sub>RAMP</sub> Power Control Range                        | 50            | 57   |      | dB    |  |
| V <sub>RAMP</sub> Loop Bandwidth                             | 2.5           | 10   |      | MHz   | 0dBm≤P <sub>OUT</sub> ≤Maximum 8PSK Average Power  |
| V <sub>RAMP</sub> Group Delay                                |               | 35   |      | ns    | 0dBm≤P <sub>OUT</sub> ≤Maximum 8PSK Average Power  |
| V <sub>RAMP</sub> Group Delay Variation                      | -20           | 0    | 20   | ns    | 0dBm≤P <sub>OUT</sub> ≤Maximum 8PSK Average Power  |

| Parameter  | Specification                                |      |      | Unit  | Condition   |
|--|--|------|------|-------|---|
|  | Min.   | Typ. | Max. |       |   |
| <b>PCS1900 Band GMSK Parameters</b>                |  |      |      |       | <b>Unless otherwise stated:</b><br>All unused RF ports terminated in 50Ω,<br>Input and Output=50Ω,<br>Temperature=25°C, V <sub>BATT</sub> =3.6V,<br>Mode=TX HB, GSM timeslots≤2,<br>P <sub>IN</sub> =3dBm, V <sub>RAMP</sub> =Max |
| Operating Frequency                                | 1850   |      | 1910 | MHz   |   |
| Input Power (P <sub>IN</sub> )                     | 0  | 3    | 6    | dBm   |   |
| Input VSWR   |  |      | 3:1  | Ratio | V <sub>RAMP</sub> =0.25V to 1.6V  |
| Maximum Output Power (Nominal)                     | 30   | 31   |      | dBm   | Temp=+25°C, V <sub>BATT</sub> =3.6V   |
| Maximum Output Power (Extreme)                     | 27.5   | 29   |      | dBm   | P <sub>IN</sub> =0dBm, Temp=+85°C, V <sub>BATT</sub> =3.2V  |
| Power Added Efficiency (Max Power)                 | 35   | 40   |      | %     |   |
| Power Added Efficiency (Rated Power)               | 30   | 35   |      | %     | P <sub>OUT</sub> =30.0dBm   |
| Peak Supply Current (Rated Power)                  | 450  | 790  | 930  | mA    | P <sub>OUT</sub> =30.0dBm   |
| Peak Supply Current (Low Power)                    | 70   | 115  | 160  | mA    | P <sub>OUT</sub> =0dBm  |
| Receive Band Noise Power                           |  |      |      |       | P <sub>OUT</sub> ≤30.0dBm, Bandwidth=100kHz   |
| 869MHz to 894MHz (EGSM)                            |  | -106 | -90  | dBm   | Out of band noise   |
| 1930MHz to 1990MHz (PCS)                           |  | -86  | -78  | dBm   | 20MHz noise   |
| Harmonics  |  |      |      |       | V <sub>RAMP</sub> =V <sub>RAMPRP</sub>  |
| 2F <sub>0</sub>                                    |  | -40  | -33  | dBm   |   |
| 3F <sub>0</sub>                                    |  | -40  | -33  | dBm   |   |
| 6F <sub>0</sub>                                    |  | -35  | -30  | dBm   |   |
| Other Harmonics, 4F <sub>0</sub> to 12.75GHz       |  | -40  | -31  | dBm   |   |
| Stability Under Load Mismatch (Spurious Emissions) |  |      | -36  | dBm   | Output Load VSWR=15:1, All phase angles,<br>Temp=-20°C to +85°C, V <sub>BATT</sub> =3.2V to 4.6V,<br>V <sub>RAMP</sub> ≤V <sub>RAMPRP</sub>   |
| Ruggedness Under Load Mismatch                     | No damage or permanent degradation to device |      |      |       | Output Load VSWR=20:1, All phase angles,<br>Temp=-20°C to +85°C, V <sub>BATT</sub> =3.2V to 4.6V,<br>V <sub>RAMP</sub> ≤V <sub>RAMPRP</sub>   |
| Forward Isolation 1                                |  | -58  | -40  | dBm   | Mode=Standby, P <sub>IN</sub> =Max, V <sub>RAMP</sub> =Min  |
| Forward Isolation 2                                |  | -25  | -20  | dBm   | Mode=TX HB, P <sub>IN</sub> =Max, V <sub>RAMP</sub> =Min  |

Notes:

V<sub>RAMPRP</sub> is defined as the V<sub>RAMP</sub> voltage required to achieve 30.0dBm at V<sub>BATT</sub>=3.6V, Temperature=25°C, P<sub>IN</sub>=3dBm

| Parameter  | Specification |      |      | Unit  | Condition   |
|--|---------------|------|------|-------|---|
|  | Min.          | Typ. | Max. |       |   |
| <b>DCS1900 Band 8PSK Parameters (Large Signal Polar)</b> |               |      |      |       | <b>Unless otherwise stated:</b><br>All unused RF ports terminated in 50Ω,<br>Input and Output=50Ω,<br>Temperature=25°C, V <sub>BATT</sub> =3.6V,<br>Mode=TX HB, GSM timeslots≤2,<br>P <sub>IN</sub> =3dBm |
| Operating Frequency                                      | 1850          |      | 1910 | MHz   |   |
| Input Power (P <sub>IN</sub> )                           | 0             | 3    | 6    | dBm   |   |
| Input VSWR   |               |      | 3:1  | Ratio | V <sub>RAMP</sub> =0.25V to 1.6V  |
| Maximum 8PSK Average Output Power (Nominal)              | 27            | 28   |      | dBm   | Temp=+25°C, V <sub>BATT</sub> =3.6V   |
| Maximum 8PSK Average Output Power (Extreme)              | 25            | 26   |      | dBm   | Temp=+85°C, V <sub>BATT</sub> =3.2V   |
| PAE  | 20            | 24   |      | %     | P <sub>OUT</sub> =27dBm   |
| Peak Supply Current (Rated Power)                        | 350           | 580  | 700  | mA    | P <sub>OUT</sub> =27dBm   |
| Peak Supply Current (Low Power)                          | 70            | 115  | 160  | mA    | P <sub>OUT</sub> =0dBm  |
| V <sub>RAMP</sub> Power Control Range                    | 50            | 57   |      | dB    |   |
| V <sub>RAMP</sub> Loop Bandwidth                         | 2.5           | 10   |      | MHz   | 0dBm≤P <sub>OUT</sub> ≤Maximum 8PSK Average Power   |
| V <sub>RAMP</sub> Group Delay                            |               | 35   |      | ns    | 0dBm≤P <sub>OUT</sub> ≤Maximum 8PSK Average Power   |
| V <sub>RAMP</sub> Group Delay Variation                  | -20           | 0    | 20   | ns    | 0dBm≤P <sub>OUT</sub> ≤Maximum 8PSK Average Power   |

| Parameter                                | Specification |      |       | Unit  | Condition   |
|--|---------------|------|-------|-------|---|
|  | Min.          | Typ. | Max.  |       |   |
| <b>Antenna Switch</b>                    |               |      |       |       | <b>Unless otherwise stated:</b><br>All unused RF ports terminated in 50Ω,<br>Input and Output=50Ω,<br>Temperature=25 °C, V <sub>BATT</sub> =3.6V, Mode=(See<br>Module Control Logic), GSM timeslots ≤ 2 |
| Operating Frequency Range 1              | 824           |      | 960   | MHz   |   |
| Operating Frequency Range 2              | 1710          |      | 1910  | MHz   |   |
| Operating Frequency Range 3              | 1920          |      | 2170  | MHz   |   |
| Input Power W1, W2, W3                   |               |      | 32    | dBm   |   |
| Input Power RX3, RX4                     |               |      | 13    | dBm   |   |
| Input VSWR                               |               |      | 1.6:1 | Ratio |   |
| Insertion Loss                           |               |      |       |       | Corrected for Evaluation Board loss   |
| W1 - W3 ports (824MHz to 960MHz)         |               | 0.7  | 1.0   | dB    | Freq=824MHz to 960MHz   |
| W1 - W3 ports (1710MHz to 1910MHz)       |               | 1.1  | 1.5   | dB    | Freq=1710MHz to 1910MHz   |
| W1 - W3 ports (1920MHz to 2170MHz)       |               | 1.2  | 1.5   | dB    | Freq=1920MHz to 2170MHz   |
| RX3 - RX4 ports (869MHz to 960MHz)       |               | 1.0  | 1.3   | dB    | Freq=869MHz to 960MHz   |
| RX3 - RX4 ports (1805MHz to 1880MHz)     |               | 1.2  | 1.7   | dB    | Freq=1805MHz to 1880MHz   |
| RX3 - RX4 ports (1930MHz to 1990MHz)     |               | 1.3  | 1.7   | dB    | Freq=1930MHz to 1990MHz   |
| Isolation/Leakage                        |               |      |       |       |   |
| Leakage LBTX to RX port                  |               | -5   | 5     | dBm   | GMSK transmit at rated power  |
| Leakage HBTX to RX port                  |               | -5   | 5     | dBm   | GMSK transmit at rated power  |
| Leakage LBTX to W port                   |               | 10   | 12    | dBm   | GMSK transmit at rated power  |
| Leakage HBTX to W port                   |               | 5    | 12    | dBm   | GMSK transmit at rated power  |
| Isolation LB W port to RX port           | 26            | 38   |       | dB    | Freq=824MHz to 915MHz   |
| Isolation HB W port to RX port           | 26            | 35   |       | dB    | Freq=1710MHz to 1980MHz   |
| Isolation LB W port to W port            | 20            | 24   |       | dB    | Freq=824MHz to 915MHz   |
| Isolation HB W port to W port            | 20            | 24   |       | dB    | Freq=1710MHz to 1980MHz   |
| Harmonics UMTS Ports                     |               |      |       |       |   |
| Harmonics LB 2F <sub>0</sub>             |               | -60  | -45   | dBm   | P <sub>IN</sub> =28dBm CW, F <sub>0</sub> =824MHz to 915MHz   |
| Harmonics LB 3F <sub>0</sub>             |               | -58  | -45   | dBm   | P <sub>IN</sub> =28dBm CW, F <sub>0</sub> =824MHz to 915MHz   |
| Harmonics LB 4F <sub>0</sub> to 12.75GHz |               | -73  | -45   | dBm   | P <sub>IN</sub> =28dBm CW, F <sub>0</sub> =824MHz to 915MHz   |
| Harmonics HB 2F <sub>0</sub>             |               | -60  | -45   | dBm   | P <sub>IN</sub> =28dBm CW, F <sub>0</sub> =1710MHz to 1980MHz   |
| Harmonics HB 3F <sub>0</sub>             |               | -70  | -45   | dBm   | P <sub>IN</sub> =28dBm CW, F <sub>0</sub> =1710MHz to 1980MHz   |
| Harmonics HB 4F <sub>0</sub> to 12.75GHz |               | -72  | -45   | dBm   | P <sub>IN</sub> =28dBm CW, F <sub>0</sub> =1710MHz to 1980MHz   |

| Parameter  | Specification |      |      | Unit | Condition   |
|--|---------------|------|------|------|---|
|  | Min.          | Typ. | Max. |      |   |
| <b>Antenna Switch (continued)</b>                  |               |      |      |      | <b>Unless otherwise stated:</b><br>All unused RF ports terminated in 50Ω,<br>Input and Output=50Ω,<br>Temperature=25 °C, V <sub>BATT</sub> =3.6V, Mode=(See<br>Module Control Logic), GSM timeslots ≤2  |
| Intermodulation Products<br>(Linearity) UMTS Ports |               |      |      |      | F <sub>0</sub> =20dBm signal on UMTS port,<br>F <sub>INT</sub> =-15dBm signal on ANT port,<br>frequency=(F <sub>IM</sub> -m*F <sub>0</sub> )/n, F <sub>IM</sub> =Spur signal<br>within RX band, created by intermod product,<br>measured at UMTS port |
| IMD2 (F <sub>0</sub> =824MHz to<br>915MHz)         |               | -110 | -97  | dBm  | F <sub>0</sub> =824MHz to 915MHz,<br>F <sub>INT</sub> =(F <sub>IM</sub> -1*F <sub>0</sub> )/1, (F <sub>IM</sub> -(-1)*F <sub>0</sub> )/1  |
| IMD3 (F <sub>0</sub> =824MHz to<br>915MHz)         |               | -115 | -97  | dBm  | F <sub>0</sub> =824MHz to 915MHz,<br>F <sub>INT</sub> =(F <sub>IM</sub> -2*F <sub>0</sub> )/-1, (F <sub>IM</sub> -(-2)*F <sub>0</sub> )/1   |
| IMD2 (F <sub>0</sub> =1710MHz to<br>1980MHz)       |               | -115 | -97  | dBm  | F <sub>0</sub> =1710MHz to 1980MHz,<br>F <sub>INT</sub> =(F <sub>IM</sub> -1*F <sub>0</sub> )/1, (F <sub>IM</sub> -(-1)*F <sub>0</sub> )/1  |
| IMD3 (F <sub>0</sub> =1710MHz to<br>1980MHz)       |               | -108 | -97  | dBm  | F <sub>0</sub> =1710MHz to 1980MHz,<br>F <sub>INT</sub> =(F <sub>IM</sub> -2*F <sub>0</sub> )/-1, (F <sub>IM</sub> -(-2)*F <sub>0</sub> )/1   |

| Pin | Function | Description  |
|-----|----------|--|
| 1   | HB_RFIN  | RF input to the high band power amplifier. DC blocked inside the module.   |
| 2   | GND      | Ground.  |
| 3   | LB_RFIN  | RF input to the low band power amplifier. DC blocked inside the module.  |
| 4   | VRAMP    | The voltage on this pin controls the output power by varying the internally regulated collector voltage on the amplifiers. Amplitude modulation of the EDGE signal is applied to this input. This is a high bandwidth input so filter considerations for performance must be addressed externally. |
| 5   | VBATT    | Main DC power supply for all circuitry in the module. Traces to this pin will have high current pulses during transmit operation. Proper decoupling and routing to handle this condition should be observed.   |
| 6   | VCTL4    | Digital Control Signal. Binary logic on VCTL1-4 sets module operating state.   |
| 7   | VCTL3    | Digital Control Signal. Binary logic on VCTL1-4 sets module operating state.   |
| 8   | VCTL2    | Digital Control Signal. Binary logic on VCTL1-4 sets module operating state.   |
| 9   | VCTL1    | Digital Control Signal. Binary logic on VCTL1-4 sets module operating state.   |
| 10  | NC       | No internal connection defined. Pin can be grounded on PCB.  |
| 11  | GND      | Ground.  |
| 12  | GND      | Ground.  |
| 13  | RX4      | Receive port 4. GSM receive port. DC blocked inside the module.  |
| 14  | RX3      | Receive port 3. GSM receive port. DC blocked inside the module.  |
| 15  | NC       | No internal connection defined. Pin can be grounded on PCB.  |
| 16  | W1       | UMTS Transmit and Receive port 1. DC blocked inside the module.  |
| 17  | ANT      | Antenna Port. 50Ω matched input/output port for RF signals going to or from the antenna.   |
| 18  | NC       | No internal connection defined. Pin can be grounded on PCB.  |
| 19  | W2       | UMTS Transmit and Receive port 2. DC blocked inside the module.  |
| 20  | W3       | UMTS Transmit and Receive port 3. DC blocked inside the module.  |
| 21  | GND      | Ground.  |
| 22  | GND      | Ground.  |
| 23  | GND      | Ground.  |
| 24  | GND      | Ground.  |
| 25  | GND      | Ground.  |
| 26  | GND      | Ground.  |
| 27  | GND      | Ground.  |
| 28  | GND      | Ground.  |
| 29  | GND      | Ground.  |
| 30  | GND      | Ground.  |
| 31  | GND      | Ground. Main thermal heat sink for module.   |

**Pin Out**  
Top Down View

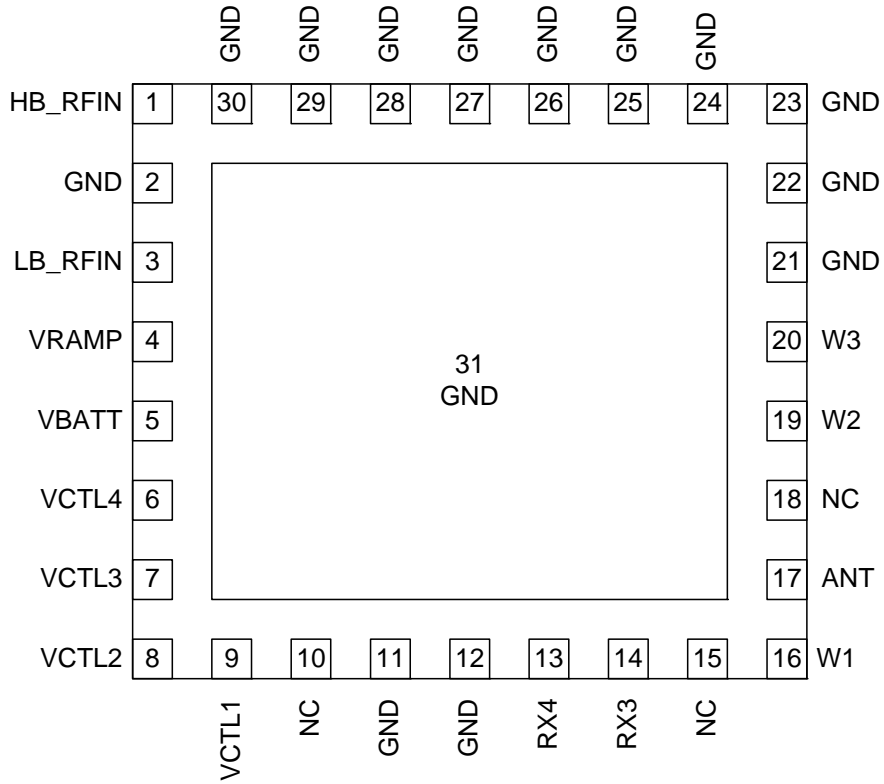

## Theory of Operation

### Overview

The RF3228 is designed for use as the final portion of the transmit section in mobile phones covering the GSM850, EGSM900, DCS1800, and PCS1900 MHz frequency bands in architectures where UMTS pass through ports are required. The RF3228 is a high power, saturated transmit module containing RFMD's patented *PowerStar*<sup>®</sup> Architecture. The module includes a multi function CMOS controller, GaAs HBT power amplifier, and matching circuitry. The integrated power control loop has been optimized for use in open loop, large signal, polar 8PSK (EDGE) modulation systems. Polar EDGE operation allows designers to have the efficiency of a *PowerStar*<sup>®</sup> PA module as well as the enhanced data rates of EDGE modulation. A single analog voltage controls output power for GSM PCLs and ramping, as well as the amplitude component of EDGE modulation. This analog voltage can be driven from the transceiver DAC to provide very predictable power control, enabling handset manufacturers to achieve simple and efficient phone calibration in production.

### Additional Features

#### Current Limiter

During normal use, a mobile phone antenna will be subjected to a variety of conditions that can affect its designed resonant frequency. This shift in frequency appears as a varying impedance to a power amplifier connected to the antenna. As the impedance presented to the power amplifier varies, so does the output power and current consumption. If left uncontrolled, power amplifier current can peak at high levels that starve other circuitry, connected to the same supply, of the required voltage to operate. This can result in a reset or shutdown of the mobile phone. The RF3228 contains an active circuit that monitors the current and adjusts the internal power control loop to prevent peak current from going above 2.6A. While this current limiter can limit transmitted power under situations where the antenna is operating at very low efficiency, it is typically more acceptable for users to have a dropped call than a phone reset.

#### Modes of Operation: GMSK and Polar EDGE

GMSK modulation is a constant RF envelope modulation scheme which encodes information in the phase of the signal and any amplitude variation is suppressed. Since no information is included in the amplitude of the signal, GMSK transmit is not sensitive to amplitude non-linearity of the PA, allowing the amplifier to operate in deep class AB or class C saturation for optimum efficiency. The power envelope is controlled by any one of a number of power control schemes.

EDGE modulation encodes information in the RF signal as a combination of both amplitude and phase. The power amplifier must be capable of re-creating both parts of the modulated signal with minimal distortion. There are several methods of creating an amplified EDGE signal. The most direct approach is to apply the EDGE modulated RF signal to a linear amplifier to boost the power. The main disadvantage to this approach is that a linear amplifier is not nearly as efficient as a saturated amplifier. Another, more complex approach is to split the EDGE signal into two components, amplitude and phase, and then recombine them in a saturated power amplifier. The benefit is that efficiency is comparable to a saturated GMSK amplifier. This method is called large signal polar modulation.

A large signal polar EDGE modulated power amplifier operates as a saturated GMSK amplifier while transmitting both GMSK or EDGE modulated signals. It is differentiated from a linear EDGE power amplifier because it always operates as a saturated amplifier. There is not a separate mode of operation that must be selected when an EDGE signal is transmitted. The RF3228 is operated in the same mode, regardless of the modulation being transmitted.

#### GMSK Operation

During GMSK transmit, RF3228 operates as a traditional *PowerStar*<sup>®</sup> module. The basic circuit diagram is shown below. The *PowerStar*<sup>®</sup> control circuit receives an analog voltage ( $V_{RAMP}$ ) which sets the amplifier output power. The *PowerStar*<sup>®</sup> architecture is essentially a closed loop method of power control that is invisible to the user. The  $V_{RAMP}$  voltage is used as a reference to a high speed linear voltage regulator which supplies the collector voltage to all stages of the amplifier. The base bias is fixed at a point that maintains deep class AB or class C transistor saturation. Because the amplifier remains in saturation at any power level, performance sensitivity to temperature, frequency, voltage and input drive level is essentially eliminated. The result is robust performance within the ETSI power versus time mask.

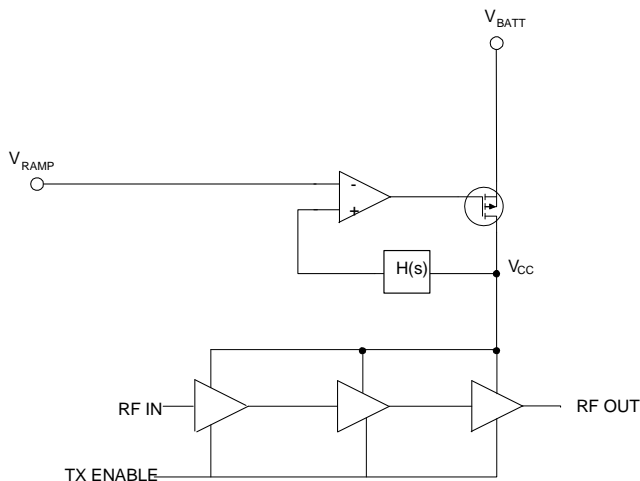

Basic PowerStar® Circuit Diagram

The PowerStar® power control relationship is described in the equation shown below where  $V_{CC}$  is the voltage from the linear regulator and the other variables are constants for a given amplifier design and load. The equation shows that load impedance affects output power, but to a lesser degree than  $V_{CC}$  supply variations. Since the architecture regulates  $V_{CC}$ , the dominant cause of power variation is eliminated. Another important result is that the equation provides a very linear relationship between  $V_{RAMP}$  and Output Power expressed as  $V_{RMS}$ .

$$P_{OUTdBm} = 10\log \left[ \frac{(2 \cdot V_{CC} - V_{SAT})^2}{8 \cdot R1 \cdot 10^{-3}} \right]$$

Output Power versus Voltage Relationship

The RF signal applied at RFIN of the amplifier must be a constant amplitude signal and should be high enough to saturate the amplifier. The input power range is indicated in the specifications. Power levels below this range will result in reduced maximum output power and the potential for more variation of output power over extreme conditions. Higher input power is unnecessary and will require more current in the circuitry driving the power amplifier. A higher input power may also couple to the output and will increase the minimum output power level.

**Polar EDGE Operation**

The large signal polar EDGE amplifier operates similar to a GMSK amplifier, except amplitude modulation is applied through its power control input. The polar EDGE amplifier operates in the same mode for both GMSK and EDGE transmission; but, there are several important differences between a GMSK only and a large signal polar EDGE power amplifier that require design optimization and potential performance trade-offs.

The power control loop bandwidth of the polar EDGE amplifier must be capable of tracking the envelope of the EDGE modulation. The envelope signal may contain frequencies up to 5 times the EDGE data rate. Accurate reproduction of the power envelope is required for acceptable EVM and modulation spectrum at the output of the amplifier. The power control loop bandwidth in the RF3228 is designed to provide at least 2MHz over extreme operating conditions. Because of this, there is no internal  $V_{RAMP}$  filter that can provide attenuation of spurious signals caused by the DAC frequency. The wide bandwidth also allows noise to enter the amplifier which can degrade the system receive band noise power performance. Filtering of the  $V_{RAMP}$  signal external to the module may be required to meet system performance requirements.

The amplitude, AM to AM, and phase, AM to PM relationship of  $V_{RAMP}$  to the amplified RF output is a critical parameter of the large signal polar amplifier performance. Also very important are the power amplifier's amplitude and phase sensitivity to input conditions. Predictable variations can be accounted for by applying predetermined coefficients at the system level. The *PowerStar*<sup>®</sup> power control method is ideally suited to amplitude modulation required for the EDGE signal, because it is inherently repeatable and insensitive to many conditions. After initial calibration, the RF3228 will maintain EDGE performance over RF input drive, battery voltage, and case temperature variation.

The large signal polar power amplifier performance must be tightly coupled to the transceiver capability since the transceiver is responsible for managing and compensating for amplitude and phase non-linearity as well as the timing alignment of the amplitude and phase signals as they pass from the transceiver, through the system, to the amplifier output. Whenever the amplifier and the polar EDGE transceiver are not working together properly, modulation spectrum and EVM problems can arise.

### Power On (Timing) Sequence

In the Power-On Sequence, there are some important set-up times associated with the control signals of the transmit module. Refer to the logic table and pin description for control signal functions. One of the critical relationships is the settling time between the amplifier being enabled and when the power control ramp up can begin. This time is often referred to as the "pedestal" and is required so that the internal power control loop and bias circuitry can settle after being turned on. The *PowerStar*<sup>®</sup> architecture usually requires 1 to 2  $\mu$ s for proper settling of the power control loop.

## GMSK/EDGE Power On/Off Sequence

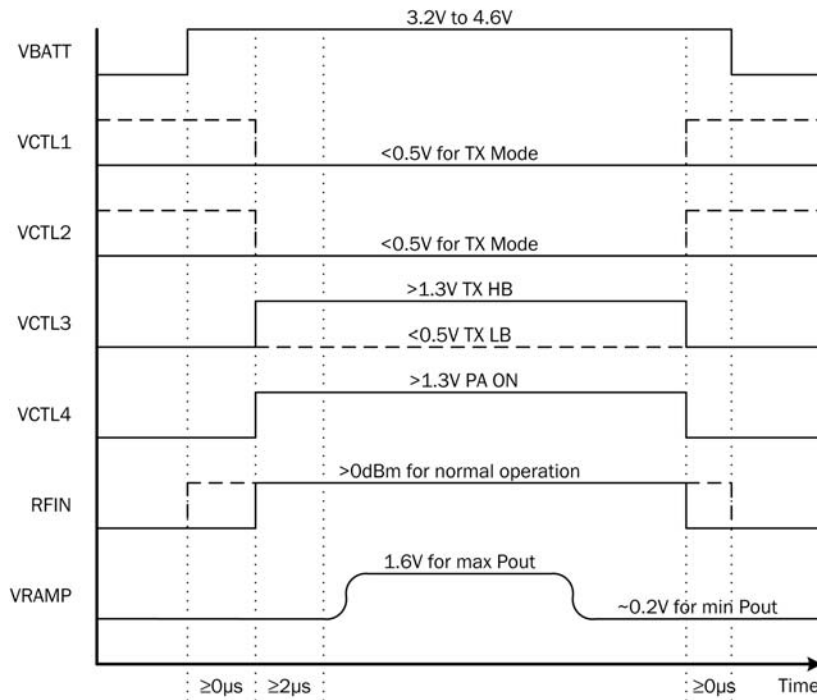

### Power On Sequence:

1. Apply VBATT
2. Apply VRAMP pedestal value ( $\approx 0.25V$ )
3. Apply RFIN
4. Apply VCTL1-4 for TX Mode
5. Ramp VRAMP for desired output power

Steps 2, 3, 4 can occur at the same time.

RFIN can be applied at any time. For good transient response it must be applied before power ramp begins.

Large signal Polar EDGE Phase modulation applied to RFIN during active part of burst.

Large signal Polar EDGE amplitude modulation applied to VRAMP during active part of burst.

The Power Down Sequence is the reverse order of the Power On Sequence.

### Power Ramping

The power ramp waveform must be created such that the output power falls into the ETSI power versus time mask. The ability to ramp the RF output power to meet ETSI switching transient and time mask requirements partially depends upon the predictability of output power versus  $V_{RAMP}$  response of the power amplifier. The *PowerStar*<sup>®</sup> control loop is very capable of meeting switching transient requirements with the proper raised cosine waveform applied to the  $V_{RAMP}$  input. Ramp times between 10 and 14  $\mu$ s can be optimized to provide excellent switching transients at high power levels. Shorter ramps will have a higher rate

of change which will produce higher transients. Longer ramps may have difficulty meeting the time mask. Optimization needs to include all power levels as the time mask requirements change with  $P_{OUT}$  levels.

The RF3228 does not include a power control loop saturation detection/correction circuit such as the  $V_{BATT}$  tracking circuit found in some *PowerStar*<sup>®</sup> modules. If  $V_{RAMP}$  is set to a voltage where the FET pass-device in the linear regulator saturates, the response time of the regulated voltage ( $V_{CC}$ ) slows significantly. Upon ramp-down, the saturated linear regulator does not react immediately, and the output power does not follow the desired ramp-down curve. The result is a discontinuity in the output power ramp and degraded switching transients. To prevent this from happening,  $V_{RAMP}$  must be limited as the supply voltage is reduced. By maintaining  $V_{RAMP} \leq 0.345 * V_{BATT} + 0.26$ , the linear regulator will avoid deep saturation and serious switching transient degradation will be avoided.

## Application Schematic

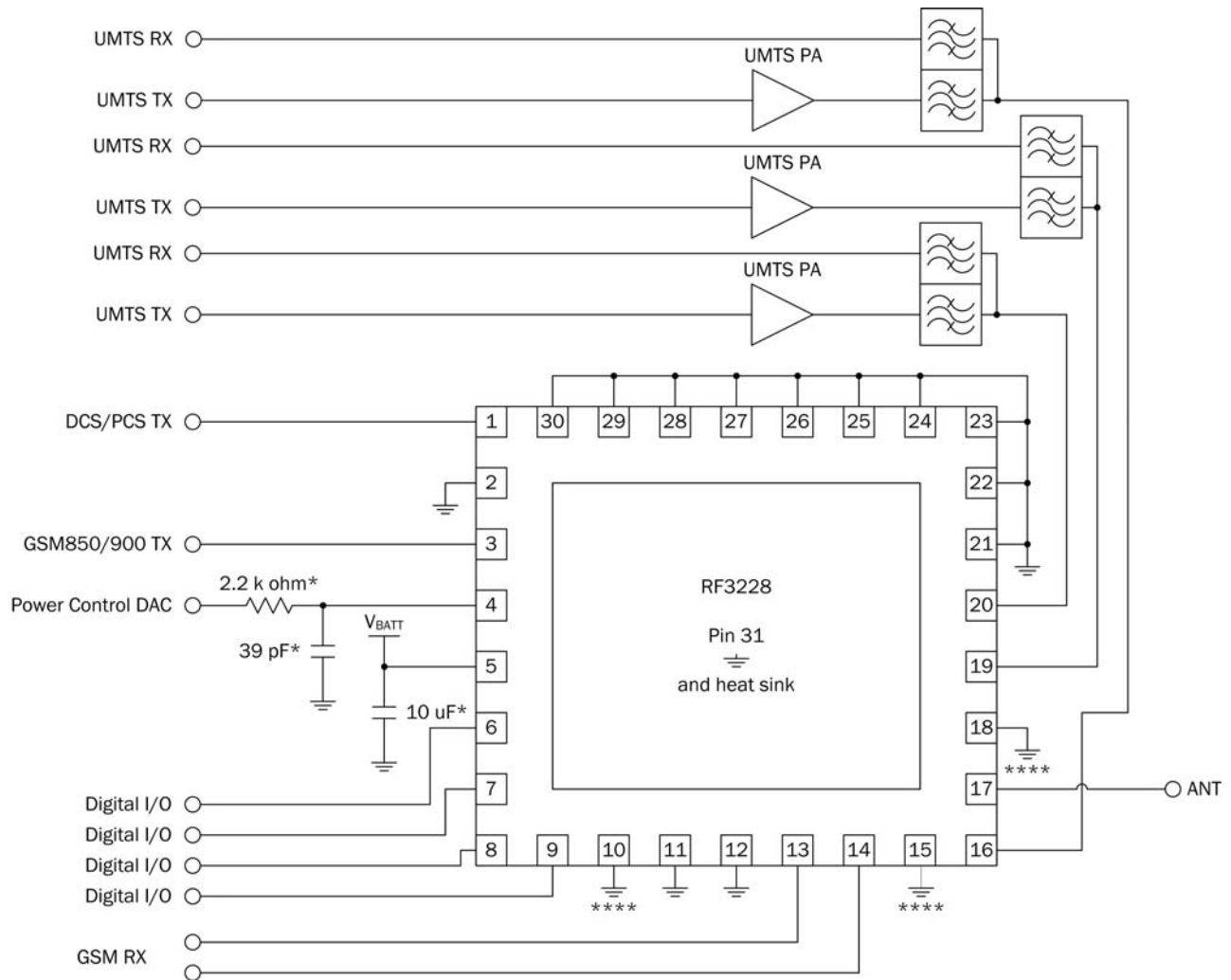

**Notes:**

\* Suggested values only. Actual requirements will vary with application.

\*\*All RF paths should be designed as 50 ohm microstrip or stripline.

\*\*\*Harmonic power from the high band amplifier near 11GHz is influenced by board layout and antenna impedance. Any matching components applied to the ANT port should be configured as a low pass filter to attenuate frequencies well above the normal GSM and UMTS transmit and receive signals.

\*\*\*\*NC pins on this module can be connected to ground.

**Evaluation Board Schematic**

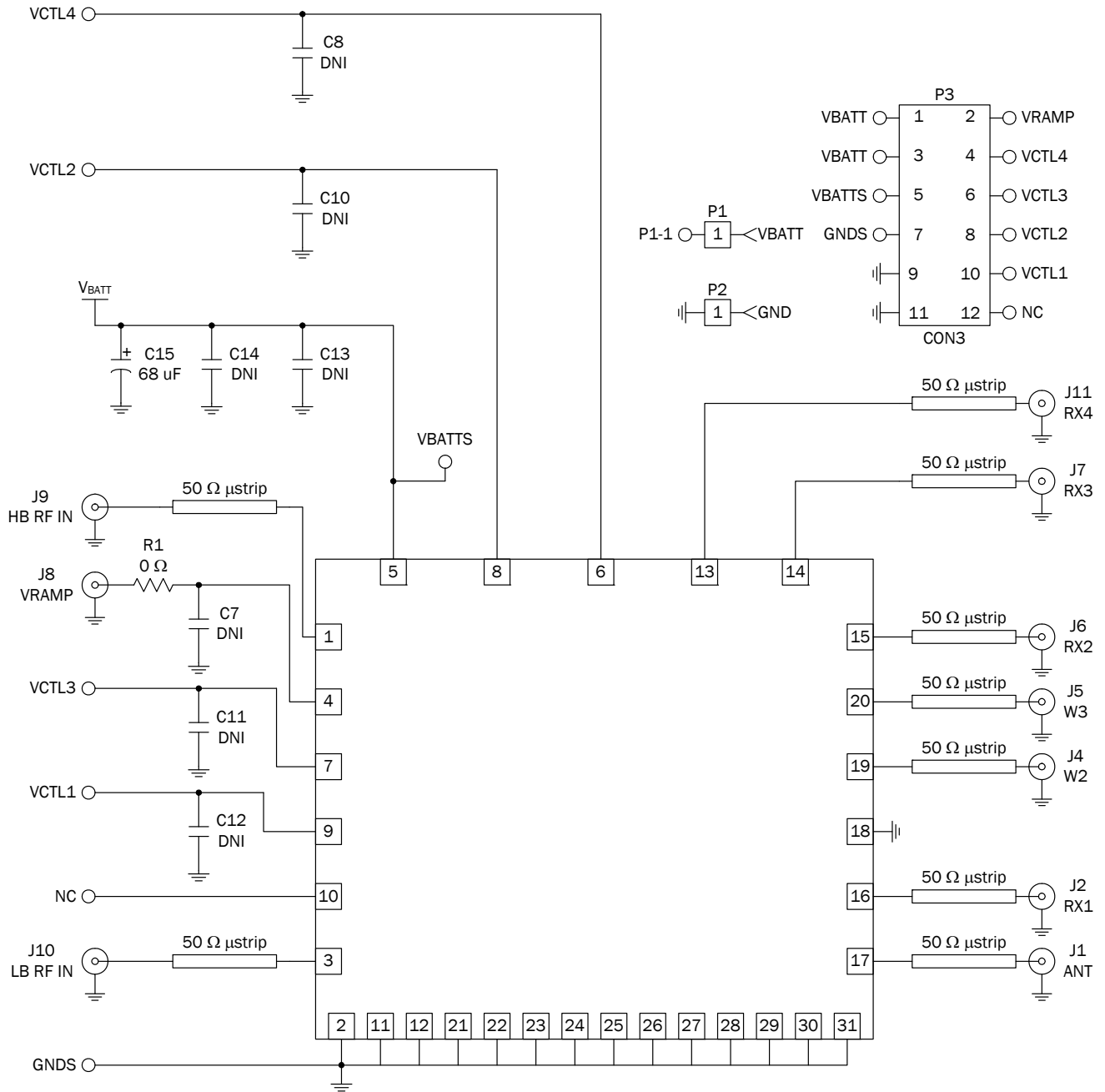

## Evaluation Board Layout

Board Size 3.5" x 2.0"

Board Thickness 0.042", Board Material R04003 Top Layer, FR-4 Core and Bottom Layer

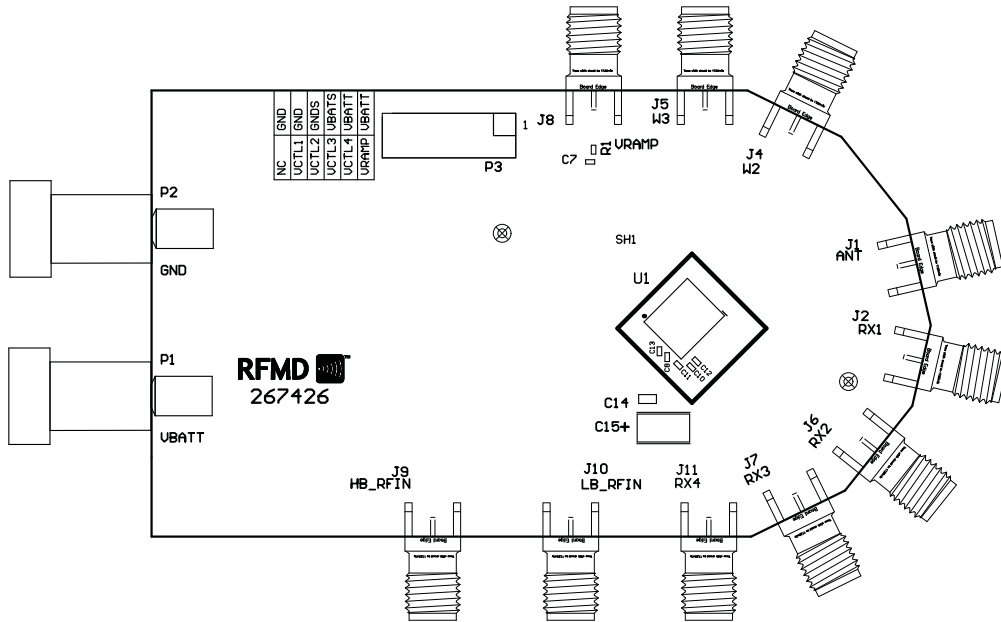

## Package Drawing

TOP VIEW

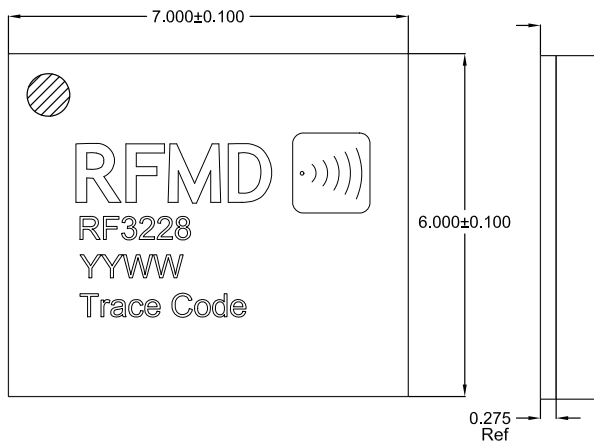

BOTTOM VIEW

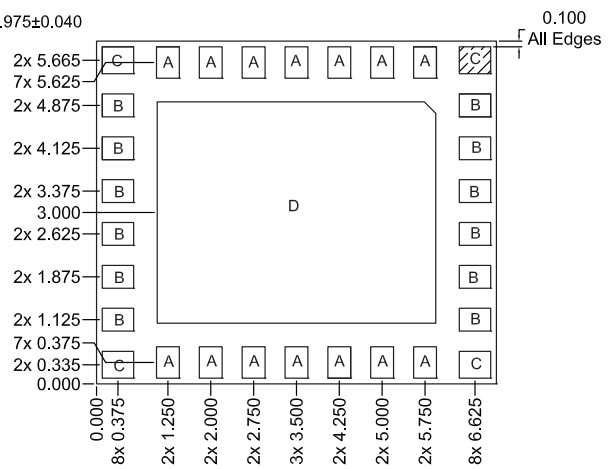

- A = 0.400 x 0.550 mm Typ
- B = 0.550 x 0.400 mm Typ
- C = 0.550 x 0.470 mm
- D = 4.875 x 3.875 mm

## PCB Design Requirements

### PCB Surface Finish

The PCB surface finish used for RFMD's qualification process is electroless nickel, immersion gold. Typical thickness is 2 µinch to 5 µinch gold over 180 µinch nickel.

### PCB Land Pattern Recommendation

PCB land patterns for RFMD components are based on IPC-7351 standards and RFMD empirical data. The pad pattern shown has been developed and tested for optimized assembly at RFMD. The PCB land pattern has been developed to accommodate lead and package tolerances. Since surface mount processes vary from company to company, careful process development is recommended.

### PCB Metal Land and Solder Mask Pattern

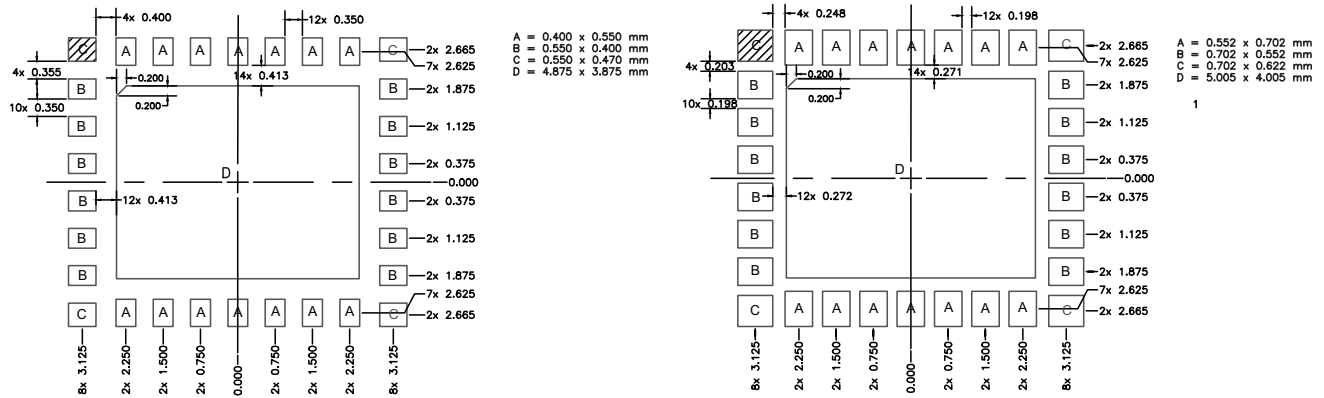

### PCB Stencil Pattern

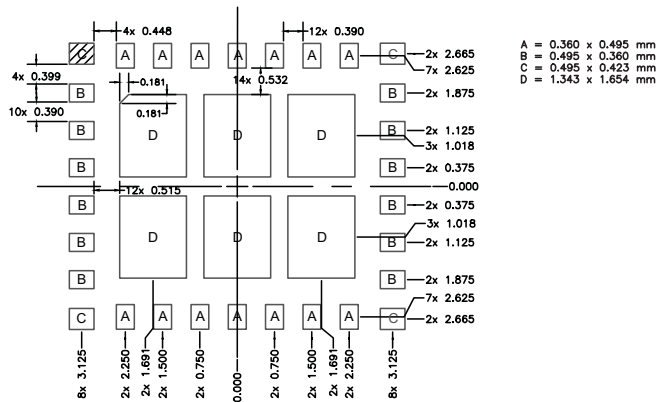

## Tape and Reel

Carrier tape basic dimensions are based on EIA 481. The pocket is designed to hold the part for shipping and loading onto SMT manufacturing equipment, while protecting the body and the solder terminals from damaging stresses. The individual pocket design can vary from vendor to vendor, but width and pitch will be consistent.

Carrier tape is wound or placed onto a shipping reel either 330mm (13 inches) in diameter or 178mm (7 inches) in diameter. The center hub design is large enough to ensure the radius formed by the carrier tape around it does not put unnecessary stress on the parts.

Prior to shipping, moisture sensitive parts (MSL level 2a-5a) are baked and placed into the pockets of the carrier tape. A cover tape is sealed over the top of the entire length of the carrier tape. The reel is sealed in a moisture barrier ESD bag with the appropriate units of desiccant and a humidity indicator card, which is placed in a cardboard shipping box. It is important to note that unused moisture sensitive parts need to be resealed in the moisture barrier bag. If the reels exceed the exposure limit and need to be rebaked, most carrier tape and shipping reels are not rated as bakeable at 125°C. If baking is required, devices may be baked according to section 4, table 4-1, of Joint Industry Standard IPC/JEDEC J-STD-033.

The table below provides information for carrier tape and reels used for shipping the devices described in this document.

### Tape and Reel

| RFMD Part Number | Reel Diameter<br>Inch (mm) | Hub Diameter<br>Inch (mm) | Width<br>(mm) | Pocket Pitch<br>(mm) | Feed   | Units per Reel |
|------------------|----------------------------|---------------------------|---------------|----------------------|--------|----------------|
| RF3228TR13       | 13 (330)                   | 4 (102)                   | 16            | 8                    | Single | 2500           |
| RF3228TR7        | 7 (178)                    | 2.4 (61)                  | 16            | 8                    | Single | 750            |

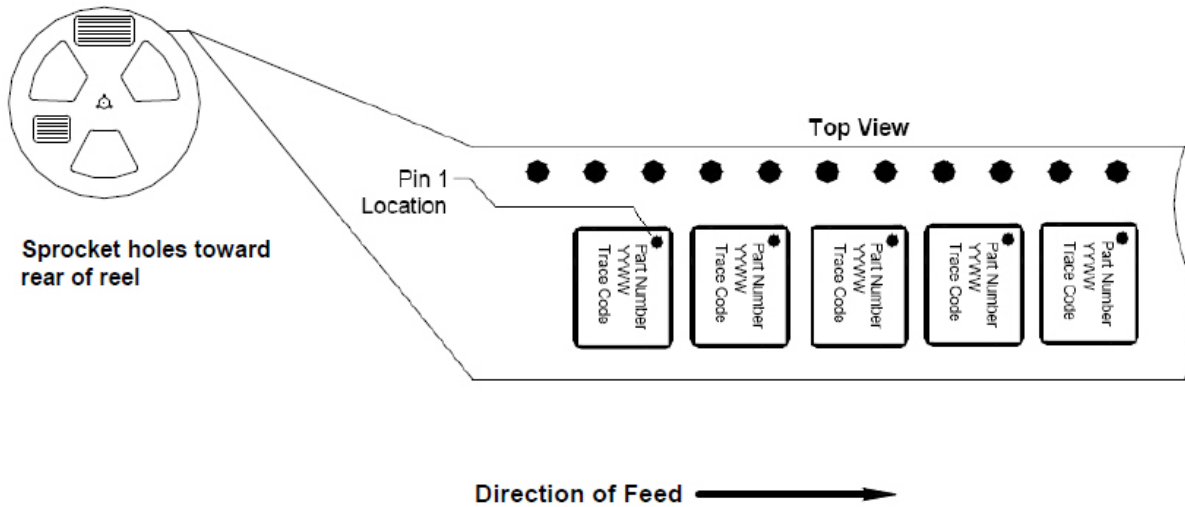

7 mmx6mm (Carrier Tape Drawing with Part Orientation)