

VHF Transistor

NPN Silicon

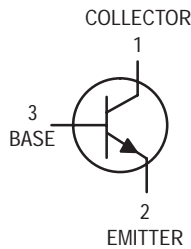

BF959

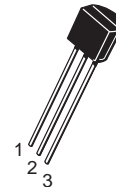

CASE 29-04, STYLE 21
TO-92 (TO-226AA)

MAXIMUM RATINGS

Rating	Symbol	Value	Unit
Collector–Emitter Voltage	V_{CE0}	20	Vdc
Collector–Base Voltage	V_{CB0}	30	Vdc
Emitter–Base Voltage	V_{EB0}	3.0	Vdc
Collector Current — Continuous	I_C	100	mAdc
Total Device Dissipation @ $T_A = 25^\circ\text{C}$ Derate above 25°C	P_D	625 5.0	mW mW/ $^\circ\text{C}$
Total Device Dissipation @ $T_C = 25^\circ\text{C}$ Derate above 25°C	P_D	1.5 12	Watt mW/ $^\circ\text{C}$
Operating and Storage Junction Temperature Range	T_J, T_{stg}	-55 to +150	$^\circ\text{C}$

THERMAL CHARACTERISTICS

Characteristic	Symbol	Max	Unit
Thermal Resistance, Junction to Ambient	$R_{\theta JA}$	200	$^\circ\text{C}/\text{W}$
Thermal Resistance, Junction to Case	$R_{\theta JC}$	83.3	$^\circ\text{C}/\text{W}$

ELECTRICAL CHARACTERISTICS ($T_A = 25^\circ\text{C}$ unless otherwise noted)

Characteristic	Symbol	Min	Typ	Max	Unit
----------------	--------	-----	-----	-----	------

OFF CHARACTERISTICS

Collector–Emitter Breakdown Voltage ($I_C = 1.0$ mAdc, $I_B = 0$)	$V_{(BR)CEO}$	20	—	—	Vdc
Collector–Base Breakdown Voltage ($I_C = 10$ μ Adc, $I_E = 0$)	$V_{(BR)CBO}$	30	—	—	Vdc
Emitter–Base Breakdown Voltage ($I_E = 10$ μ Adc, $I_C = 0$)	$V_{(BR)EBO}$	3.0	—	—	Vdc
Collector Cutoff Current ($V_{CB} = 20$ Vdc, $I_E = 0$)	I_{CBO}	—	—	100	nAdc

ON CHARACTERISTICS

DC Current Gain ($I_C = 5.0$ mAdc, $V_{CE} = 10$ Vdc) ($I_C = 20$ mAdc, $V_{CE} = 10$ Vdc)	h_{FE}	35 40	— —	— —	—
Collector–Emitter Saturation Voltage ($I_C = 30$ mAdc, $I_B = 2.0$ mAdc)	$V_{CE(sat)}$	—	—	1.0	Vdc
Base–Emitter Saturation Voltage ($I_C = 30$ mAdc, $I_B = 2.0$ mAdc)	$V_{BE(sat)}$	—	—	1.0	Vdc

SMALL-SIGNAL CHARACTERISTICS

Current–Gain — Bandwidth Product ($I_C = 20$ mAdc, $V_{CE} = 10$ Vdc, $f = 100$ MHz) ($I_C = 30$ mAdc, $V_{CE} = 10$ Vdc, $f = 100$ MHz)	f_T	700 600	— —	— —	MHz
Common Emitter Feedback Capacitance ($V_{CB} = 10$ Vdc, $P_f = 0$, $f = 10$ MHz)	C_{re}	—	0.65	—	pF
Noise Figure ($I_C = 4.0$ mA, $V_{CE} = 10$ V, $R_S = 50$ Ω , $f = 200$ MHz)	N_f	—	3.0	—	dB

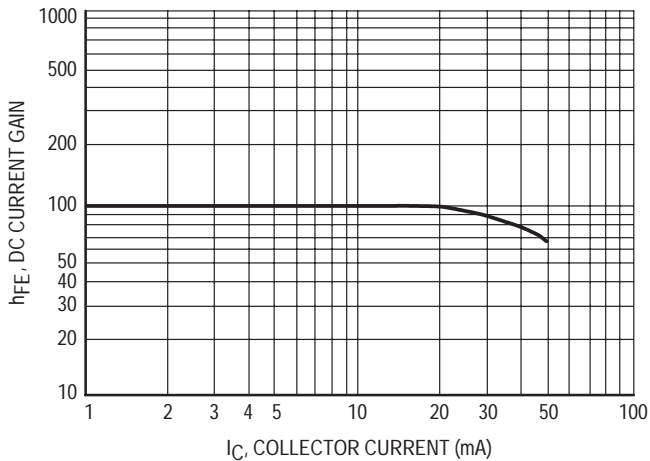

Figure 1. h_{FE} at 10 V

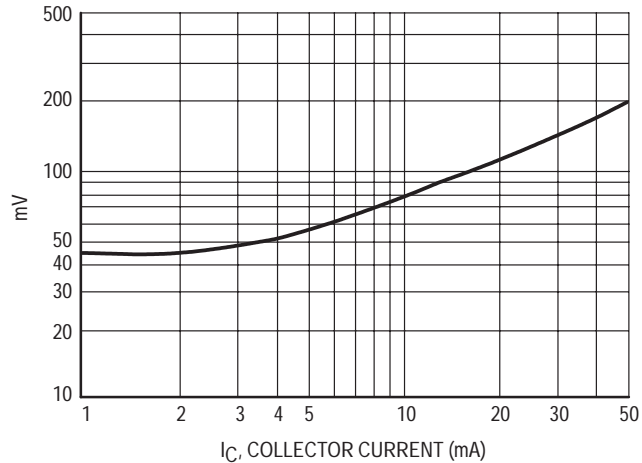

Figure 2. $V_{CE(sat)}$ at $I_C/I_B = 10$

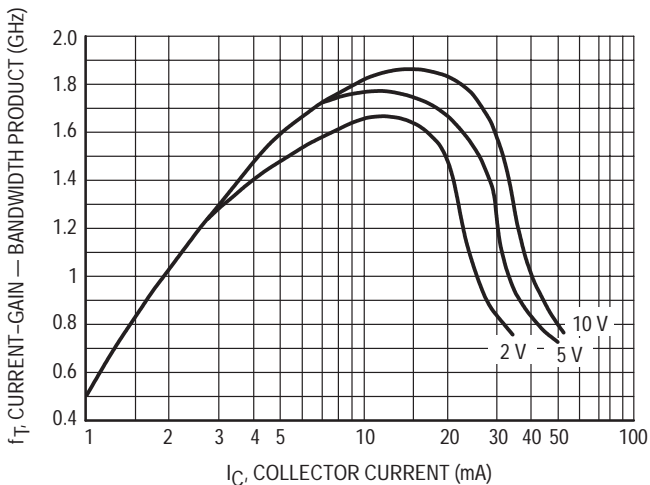

Figure 3. Current-Gain — Bandwidth Product

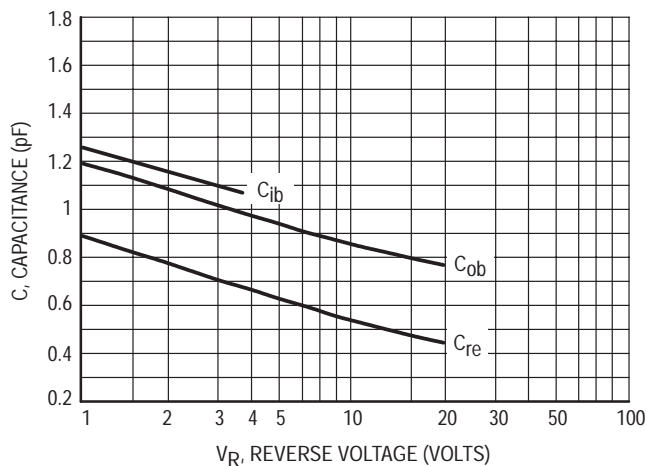

Figure 4. Capacitances

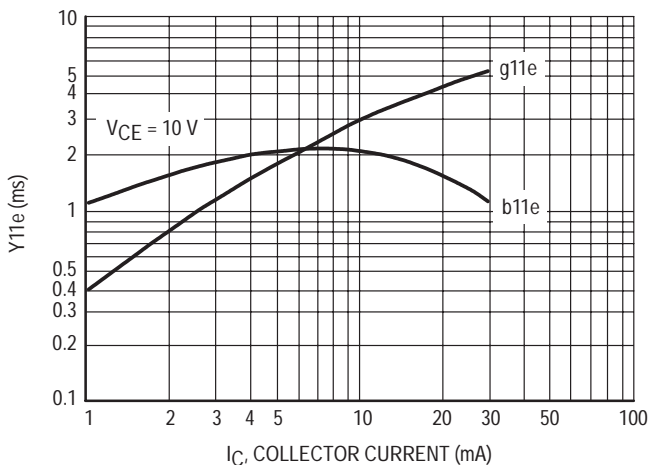

Figure 5. Input Impedance at 30 MHz

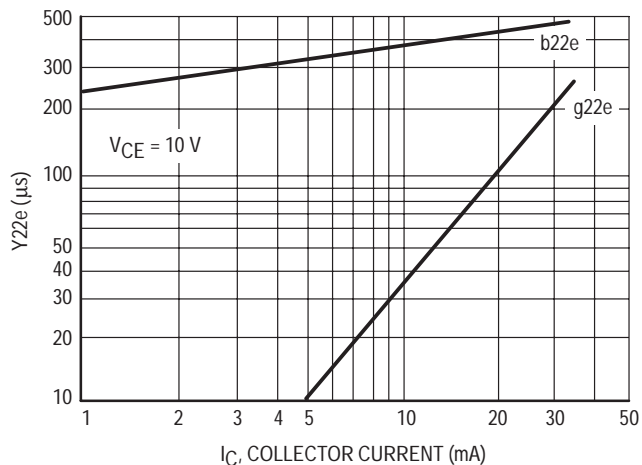

Figure 6. Output Impedance at 30 MHz

EMBOSSSED TAPE AND REEL

SOT-23, SC-59, SC-70/SOT-323, SC-90/SOT-416, SOT-223 and SO-16 packages are available only in Tape and Reel. Use the appropriate suffix indicated below to order any of the SOT-23, SC-59, SC-70/SOT-323, SOT-223 and SO-16 packages. (See Section 6 on Packaging for additional information).

- SOT-23: available in 8 mm Tape and Reel
Use the device title (which already includes the "T1" suffix) to order the 7 inch/3000 unit reel.
Replace the "T1" suffix in the device title with a "T3" suffix to order the 13 inch/10,000 unit reel.
- SC-59: available in 8 mm Tape and Reel
Use the device title (which already includes the "T1" suffix) to order the 7 inch/3000 unit reel.
Replace the "T1" suffix in the device title with a "T3" suffix to order the 13 inch/10,000 unit reel.
- SC-70/
SOT-323: available in 8 mm Tape and Reel
Use the device title (which already includes the "T1" suffix) to order the 7 inch/3000 unit reel.
Replace the "T1" suffix in the device title with a "T3" suffix to order the 13 inch/10,000 unit reel.
- SOT-223: available in 12 mm Tape and Reel
Use the device title (which already includes the "T1" suffix) to order the 7 inch/1000 unit reel.
Replace the "T1" suffix in the device title with a "T3" suffix to order the 13 inch/4000 unit reel.
- SO-16: available in 16 mm Tape and Reel
Add an "R1" suffix to the device title to order the 7 inch/500 unit reel.
Add an "R2" suffix to the device title to order the 13 inch/2500 unit reel.

RADIAL TAPE IN FAN FOLD BOX OR REEL

TO-92 packages are available in both bulk shipments and in Radial Tape in Fan Fold Boxes or Reels. Fan Fold Boxes and Radial Tape Reel are the best methods for capturing devices for automatic insertion in printed circuit boards.

- TO-92: available in Fan Fold Box
Add an "RLR" suffix and the appropriate Style code* to the device title to order the Fan Fold box.
- available in 365 mm Radial Tape Reel
Add an "RLR" suffix and the appropriate Style code* to the device title to order the Radial Tape Reel.

*Refer to Section 6 on Packaging for Style code characters and additional information on ordering requirements.

DEVICE MARKINGS/DATE CODE CHARACTERS

SOT-23, SC-59, SC-70/SOT-323, and the SC-90/SOT-416 packages have a device marking and a date code etched on the device. The generic example below depicts both the device marking and a representation of the date code that appears on the SC-70/SOT-323, SC-59 and SOT-23 packages.



The "D" represents a smaller alpha digit Date Code. The Date Code indicates the actual month in which the part was manufactured.

Tape and Reel Specifications and Packaging Specifications

Embossed Tape and Reel is used to facilitate automatic pick and place equipment feed requirements. The tape is used as the shipping container for various products and requires a minimum of handling. The antistatic/conductive tape provides a secure cavity for the product when sealed with the "peel-back" cover tape.

- Two Reel Sizes Available (7" and 13")
- Used for Automatic Pick and Place Feed Systems
- Minimizes Product Handling
- EIA 481, -1, -2
- SOD-123, SC-59, SC-70/SOT-323, SC-70ML/SOT-363, SOT-23, TSOP-6, in 8 mm Tape
- SOT-223 in 12 mm Tape
- SO-14, SO-16 in 16 mm Tape

Use the standard device title and add the required suffix as listed in the option table on the following page. Note that the individual reels have a finite number of devices depending on the type of product contained in the tape. Also note the minimum lot size is one full reel for each line item, and orders are required to be in increments of the single reel quantity.

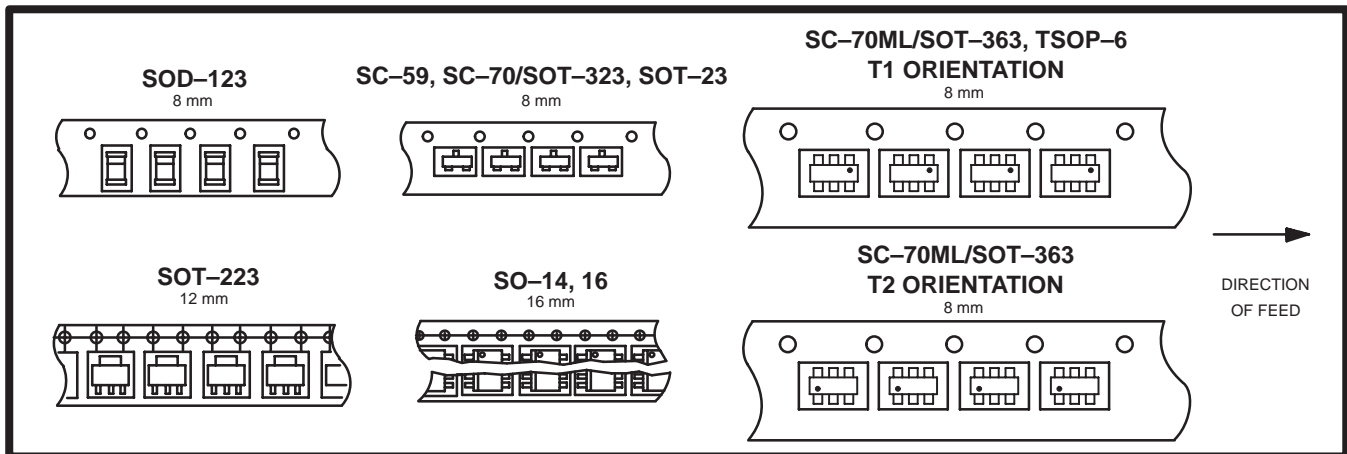

EMBOSSED TAPE AND REEL ORDERING INFORMATION

Package	Tape Width (mm)	Pitch (mm (inch))	Reel Size (mm (inch))	Devices Per Reel and Minimum Order Quantity	Device Suffix
SC-59	8	4.0 ± 0.1 (.157 ± .004)	178 (7)	3,000	T1
SC-70/SOT-323	8	4.0 ± 0.1 (.157 ± .004)	178 (7)	3,000	T1
	8		330 (13)	10,000	T3
SO-14	16	8.0 ± 0.1 (.315 ± .004)	178 (7)	500	R1
	16		330 (13)	2,500	R2
SO-16	16	8.0 ± 0.1 (.315 ± .004)	178 (7)	500	R1
	16		330 (13)	2,500	R2
SOD-123	8	4.0 ± 0.1 (.157 ± .004)	178 (7)	3,000	T1
	8		330 (13)	10,000	T3
SOT-23	8	4.0 ± 0.1 (.157 ± .004)	178 (7)	3,000	T1
	8		330 (13)	10,000	T3
SOT-223	12	8.0 ± 0.1 (.315 ± .004)	178 (7)	1,000	T1
	12		330 (13)	4,000	T3
SC-70ML/SOT-363	8	4.0 ± 0.1 (.157 ± .004)	178 (7)	3,000	T1
	8		178 (7)	3,000	T2
TSOP-6	8	4.0 ± 0.1 (.157 ± .004)	178 (7)	3,000	T1

EMBOSSED TAPE AND REEL DATA FOR DISCRETES

CARRIER TAPE SPECIFICATIONS

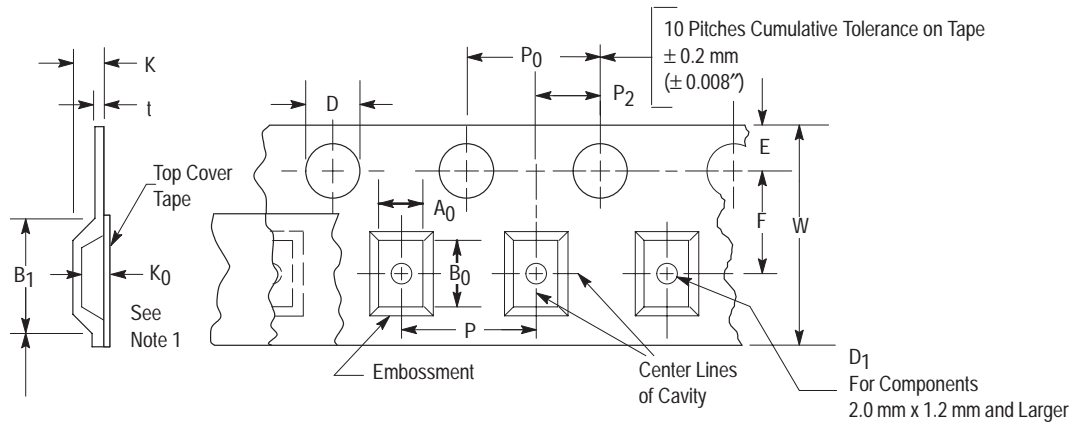

For Machine Reference Only
Including Draft and RADII
Concentric Around B_0

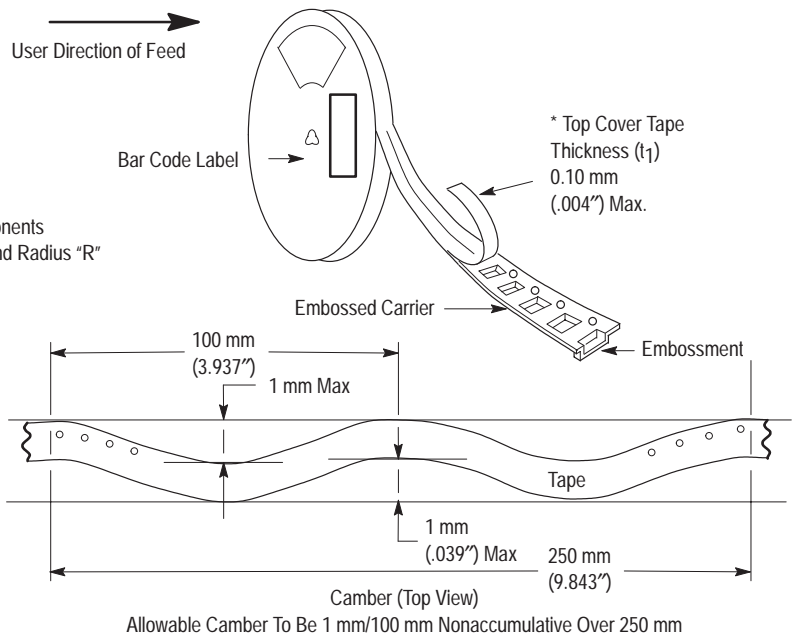
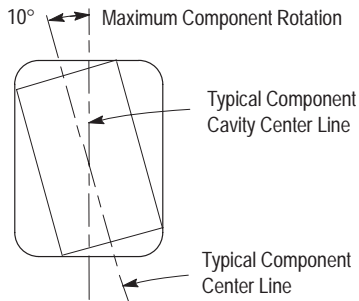
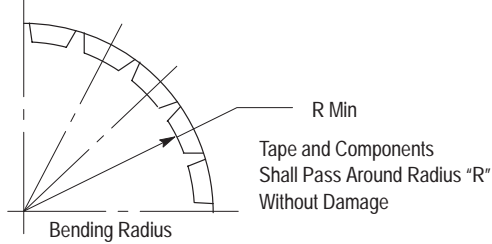

DIMENSIONS

Tape Size	B_1 Max	D	D_1	E	F	K	P_0	P_2	R Min	T Max	W Max
8 mm	4.55 mm (.179")	1.5 ± 0.1 mm -0.0 (.059 ± .004" -0.0)	1.0 Min (.039")	1.75 ± 0.1 mm (.069 ± .004")	3.5 ± 0.05 mm (.138 ± .002")	2.4 mm Max (.094")	4.0 ± 0.1 mm (.157 ± .004")	2.0 ± 0.1 mm (.079 ± .002")	25 mm (.98")	0.6 mm (.024")	8.3 mm (.327")
12 mm	8.2 mm (.323")		1.5 mm Min (.060")		5.5 ± 0.05 mm (.217 ± .002")	6.4 mm Max (.252")			30 mm (1.18")		12 ± .30 mm (.470 ± .012")
16 mm	12.1 mm (.476")				7.5 ± 0.10 mm (.295 ± .004")	7.9 mm Max (.311")					16.3 mm (.642")
24 mm	20.1 mm (.791")				11.5 ± 0.1 mm (.453 ± .004")	11.9 mm Max (.468")					24.3 mm (.957")

Metric dimensions govern — English are in parentheses for reference only.

NOTE 1: A_0 , B_0 , and K_0 are determined by component size. The clearance between the components and the cavity must be within .05 mm min. to .50 mm max., the component cannot rotate more than 10° within the determined cavity.

NOTE 2: If B_1 exceeds 4.2 mm (.165) for 8 mm embossed tape, the tape may not feed through all tape feeders.

NOTE 3: Pitch information is contained in the Embossed Tape and Reel Ordering Information on pg. 5.12-3.

EMBOSSED TAPE AND REEL DATA FOR DISCRETES

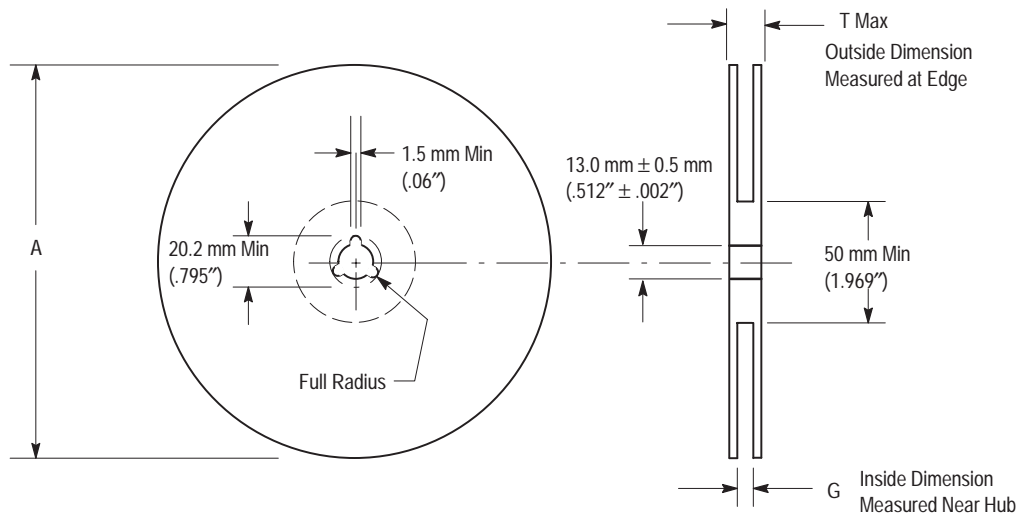

Size	A Max	G	T Max
8 mm	330 mm (12.992")	8.4 mm + 1.5 mm, -0.0 (.33" + .059", -0.00)	14.4 mm (.56")
12 mm	330 mm (12.992")	12.4 mm + 2.0 mm, -0.0 (.49" + .079", -0.00)	18.4 mm (.72")
16 mm	360 mm (14.173")	16.4 mm + 2.0 mm, -0.0 (.646" + .078", -0.00)	22.4 mm (.882")
24 mm	360 mm (14.173")	24.4 mm + 2.0 mm, -0.0 (.961" + .070", -0.00)	30.4 mm (1.197")

Reel Dimensions

Metric Dimensions Govern — English are in parentheses for reference only

TO-92 EIA, IEC, EIAJ

Radial Tape in Fan Fold Box or On Reel

Radial tape in fan fold box or on reel of the reliable TO-92 package are the best methods of capturing devices for automatic insertion in printed circuit boards. These methods of taping are compatible with various equipment for active and passive component insertion.

- Available in Fan Fold Box
- Available on 365 mm Reels
- Accommodates All Standard Inserters
- Allows Flexible Circuit Board Layout
- 2.5 mm Pin Spacing for Soldering
- EIA-468, IEC 286-2, EIAJ RC1008B

Ordering Notes:

When ordering radial tape in fan fold box or on reel, specify the style per Figures 3 through 8. Add the suffix "RLR" and "Style" to the device title, i.e. MPS3904RLRA. This will be a standard MPS3904 radial taped and supplied on a reel per Figure 9.

Fan Fold Box Information — Order in increments of 2000.

Reel Information — Order in increments of 2000.

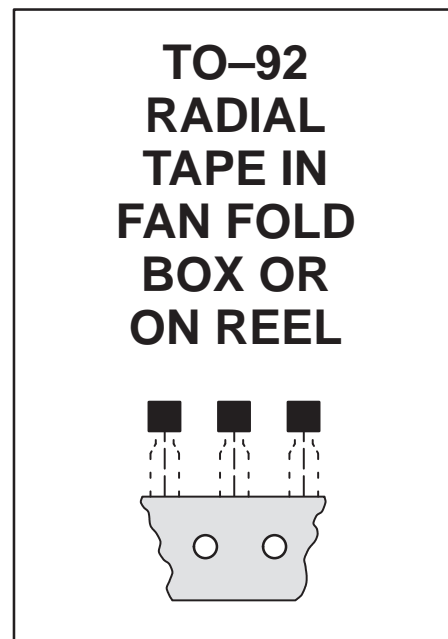

US/European Suffix Conversions

US	EUROPE
RLRA	RL
RLRE	RL1
RLRM	ZL1

TO-92 EIA RADIAL TAPE IN FAN FOLD BOX OR ON REEL

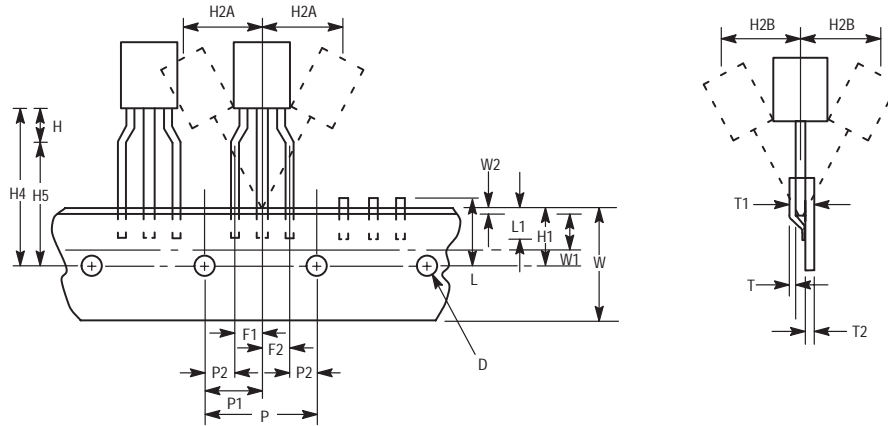

Figure 1. Device Positioning on Tape

Symbol	Item	Specification			
		Inches		Millimeter	
		Min	Max	Min	Max
D	Tape Feedhole Diameter	0.1496	0.1653	3.8	4.2
D2	Component Lead Thickness Dimension	0.015	0.020	0.38	0.51
F1, F2	Component Lead Pitch	0.0945	0.110	2.4	2.8
H	Bottom of Component to Seating Plane	.059	.156	1.5	4.0
H1	Feedhole Location	0.3346	0.3741	8.5	9.5
H2A	Deflection Left or Right	0	0.039	0	1.0
H2B	Deflection Front or Rear	0	0.051	0	1.0
H4	Feedhole to Bottom of Component	0.7086	0.768	18	19.5
H5	Feedhole to Seating Plane	0.610	0.649	15.5	16.5
L	Defective Unit Clipped Dimension	0.3346	0.433	8.5	11
L1	Lead Wire Enclosure	0.09842	—	2.5	—
P	Feedhole Pitch	0.4921	0.5079	12.5	12.9
P1	Feedhole Center to Center Lead	0.2342	0.2658	5.95	6.75
P2	First Lead Spacing Dimension	0.1397	0.1556	3.55	3.95
T	Adhesive Tape Thickness	0.06	0.08	0.15	0.20
T1	Overall Taped Package Thickness	—	0.0567	—	1.44
T2	Carrier Strip Thickness	0.014	0.027	0.35	0.65
W	Carrier Strip Width	0.6889	0.7481	17.5	19
W1	Adhesive Tape Width	0.2165	0.2841	5.5	6.3
W2	Adhesive Tape Position	.0059	0.01968	.15	0.5

NOTES:

1. Maximum alignment deviation between leads not to be greater than 0.2 mm.
2. Defective components shall be clipped from the carrier tape such that the remaining protrusion (L) does not exceed a maximum of 11 mm.
3. Component lead to tape adhesion must meet the pull test requirements established in Figures 5, 6 and 7.
4. Maximum non-cumulative variation between tape feed holes shall not exceed 1 mm in 20 pitches.
5. Holddown tape not to extend beyond the edge(s) of carrier tape and there shall be no exposure of adhesive.
6. No more than 1 consecutive missing component is permitted.
7. A tape trailer and leader, having at least three feed holes is required before the first and after the last component.
8. Splices will not interfere with the sprocket feed holes.

TO-92 EIA RADIAL TAPE IN FAN FOLD BOX OR ON REEL

FAN FOLD BOX STYLES

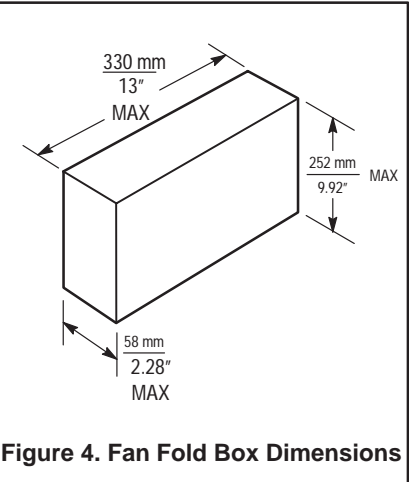
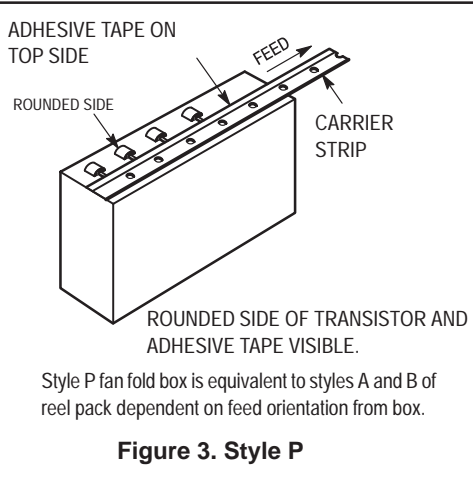
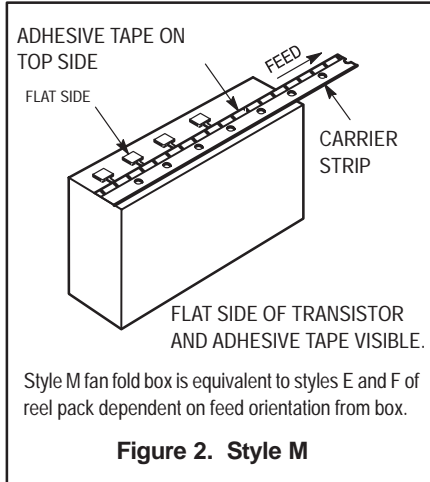

ADHESION PULL TESTS

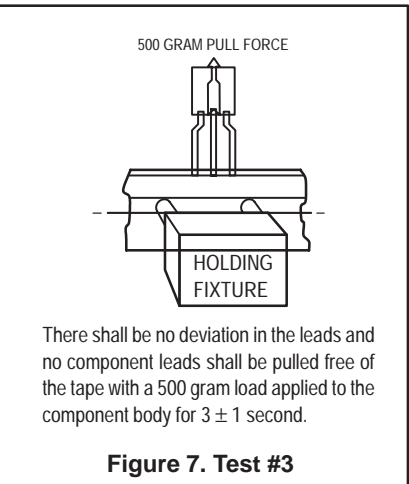
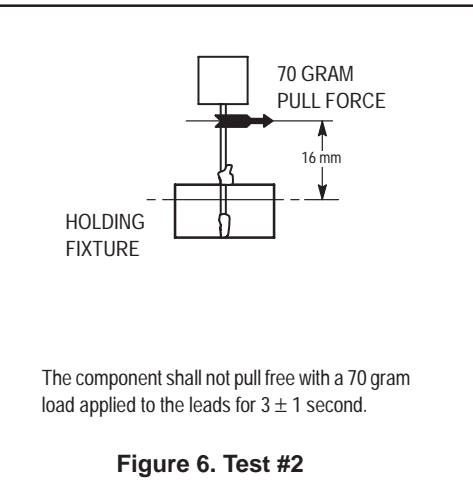
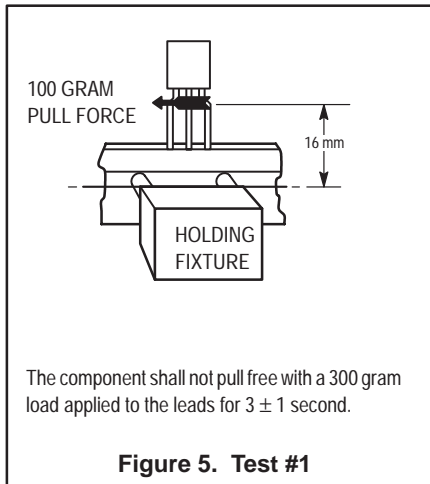

TO-92 EIA RADIAL TAPE IN FAN FOLD BOX OR ON REEL

REEL STYLES

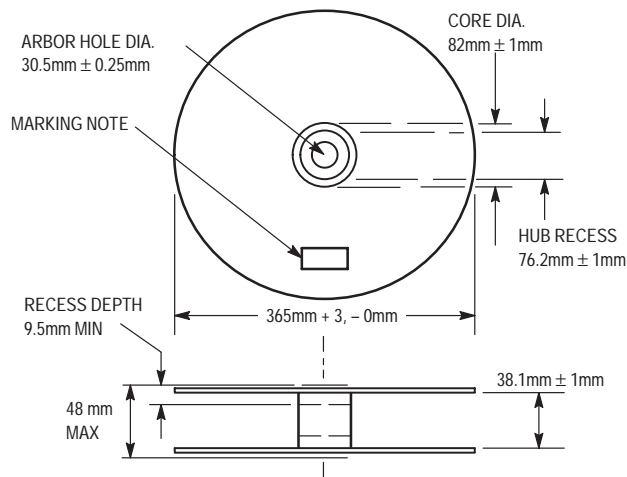

Material used must not cause deterioration of components or degrade lead solderability

Figure 8. Reel Specifications

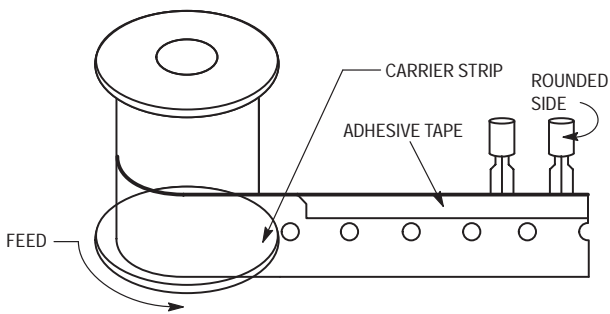

Rounded side of transistor and adhesive tape visible.

Figure 9. Style A

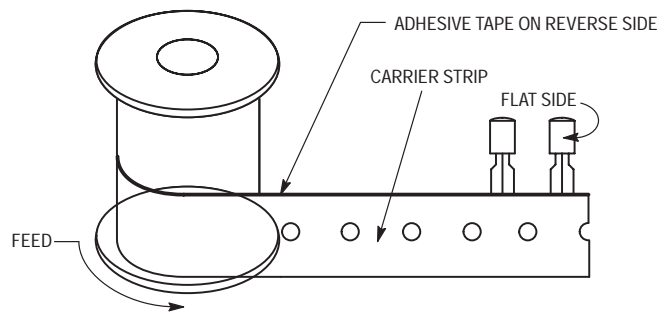

Flat side of transistor and carrier strip visible (adhesive tape on reverse side).

Figure 10. Style B

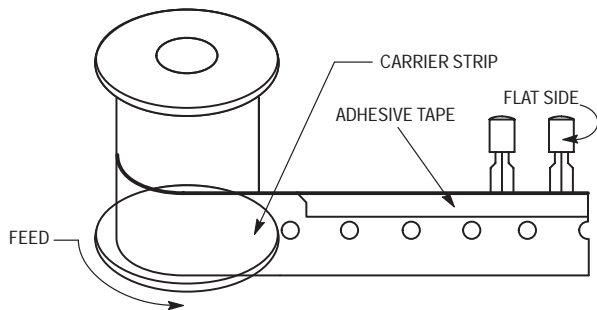

Flat side of transistor and adhesive tape visible.

Figure 11. Style E

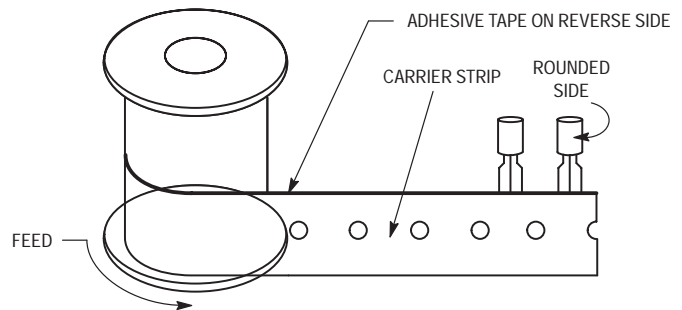

Rounded side of transistor and carrier strip visible (adhesive tape on reverse side).

Figure 12. Style F

INFORMATION FOR USING SURFACE MOUNT PACKAGES

RECOMMENDED FOOTPRINTS FOR SURFACE MOUNTED APPLICATIONS

Surface mount board layout is a critical portion of the total design. The footprint for the semiconductor packages must be the correct size to ensure proper solder connection inter-

face between the board and the package. With the correct pad geometry, the packages will self align when subjected to a solder reflow process.

POWER DISSIPATION FOR A SURFACE MOUNT DEVICE

The power dissipation for a surface mount device is a function of the drain/collector pad size. These can vary from the minimum pad size for soldering to a pad size given for maximum power dissipation. Power dissipation for a surface mount device is determined by $T_{J(max)}$, the maximum rated junction temperature of the die, $R_{\theta JA}$, the thermal resistance from the device junction to ambient, and the operating temperature, T_A . Using the values provided on the data sheet, P_D can be calculated as follows:

$$P_D = \frac{T_{J(max)} - T_A}{R_{\theta JA}}$$

The values for the equation are found in the maximum ratings table on the data sheet. Substituting these values into the equation for an ambient temperature T_A of 25°C, one can calculate the power dissipation of the device. For example, for a SOT-223 device, P_D is calculated as follows.

$$P_D = \frac{150^\circ\text{C} - 25^\circ\text{C}}{156^\circ\text{C/W}} = 800 \text{ milliwatts}$$

The 156°C/W for the SOT-223 package assumes the use of the recommended footprint on a glass epoxy printed circuit board to achieve a power dissipation of 800 milliwatts. There are other alternatives to achieving higher power dissipation from the surface mount packages. One is to increase the area of the drain/collector pad. By increasing the area of the drain/collector pad, the power dissipation can be increased.

Although the power dissipation can almost be doubled with this method, area is taken up on the printed circuit board which can defeat the purpose of using surface mount technology. For example, a graph of $R_{\theta JA}$ versus drain pad area is shown in Figure 1.

Another alternative would be to use a ceramic substrate or an aluminum core board such as Thermal Clad™. Using a board material such as Thermal Clad, an aluminum core board, the power dissipation can be doubled using the same footprint.

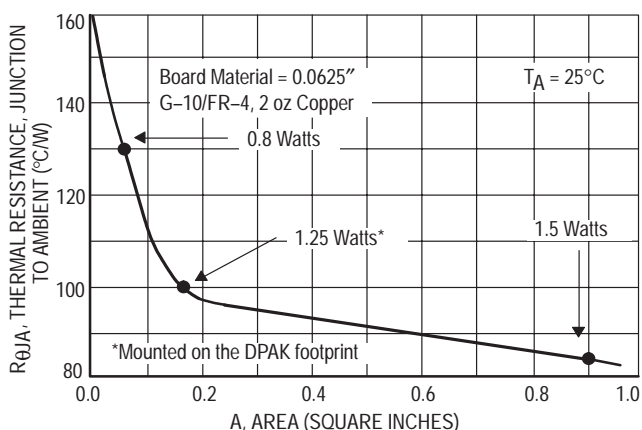

Figure 1. Thermal Resistance versus Drain Pad Area for the SOT-223 Package (Typical)

SOLDER STENCIL GUIDELINES

Prior to placing surface mount components onto a printed circuit board, solder paste must be applied to the pads. Solder stencils are used to screen the optimum amount. These stencils are typically 0.008 inches thick and may be made of brass or stainless steel. For packages such as the

SOT-23, SC-59, SC-70/SOT-323, SC-90/SOT-416, SOD-123, SOT-223, SOT-363, SO-14, SO-16, and TSOP-6 packages, the stencil opening should be the same as the pad size or a 1:1 registration.

SOLDERING PRECAUTIONS

The melting temperature of solder is higher than the rated temperature of the device. When the entire device is heated to a high temperature, failure to complete soldering within a short time could result in device failure. Therefore, the following items should always be observed in order to minimize the thermal stress to which the devices are subjected.

- Always preheat the device.
- The delta temperature between the preheat and soldering should be 100°C or less.*
- When preheating and soldering, the temperature of the leads and the case must not exceed the maximum temperature ratings as shown on the data sheet. When using infrared heating with the reflow soldering method, the difference should be a maximum of 10°C.

- The soldering temperature and time should not exceed 260°C for more than 10 seconds.
- When shifting from preheating to soldering, the maximum temperature gradient shall be 5°C or less.
- After soldering has been completed, the device should be allowed to cool naturally for at least three minutes. Gradual cooling should be used since the use of forced cooling will increase the temperature gradient and will result in latent failure due to mechanical stress.
- Mechanical stress or shock should not be applied during cooling.

* Soldering a device without preheating can cause excessive thermal shock and stress which can result in damage to the device.

TYPICAL SOLDER HEATING PROFILE

For any given circuit board, there will be a group of control settings that will give the desired heat pattern. The operator must set temperatures for several heating zones and a figure for belt speed. Taken together, these control settings make up a heating "profile" for that particular circuit board. On machines controlled by a computer, the computer remembers these profiles from one operating session to the next. Figure 2 shows a typical heating profile for use when soldering a surface mount device to a printed circuit board. This profile will vary among soldering systems, but it is a good starting point. Factors that can affect the profile include the type of soldering system in use, density and types of components on the board, type of solder used, and the type of board or substrate material being used. This profile shows temperature versus time. The line on the graph shows the

actual temperature that might be experienced on the surface of a test board at or near a central solder joint. The two profiles are based on a high density and a low density board. The Vitronics SMD310 convection/infrared reflow soldering system was used to generate this profile. The type of solder used was 62/36/2 Tin Lead Silver with a melting point between 177–189°C. When this type of furnace is used for solder reflow work, the circuit boards and solder joints tend to heat first. The components on the board are then heated by conduction. The circuit board, because it has a large surface area, absorbs the thermal energy more efficiently, then distributes this energy to the components. Because of this effect, the main body of a component may be up to 30 degrees cooler than the adjacent solder joints.

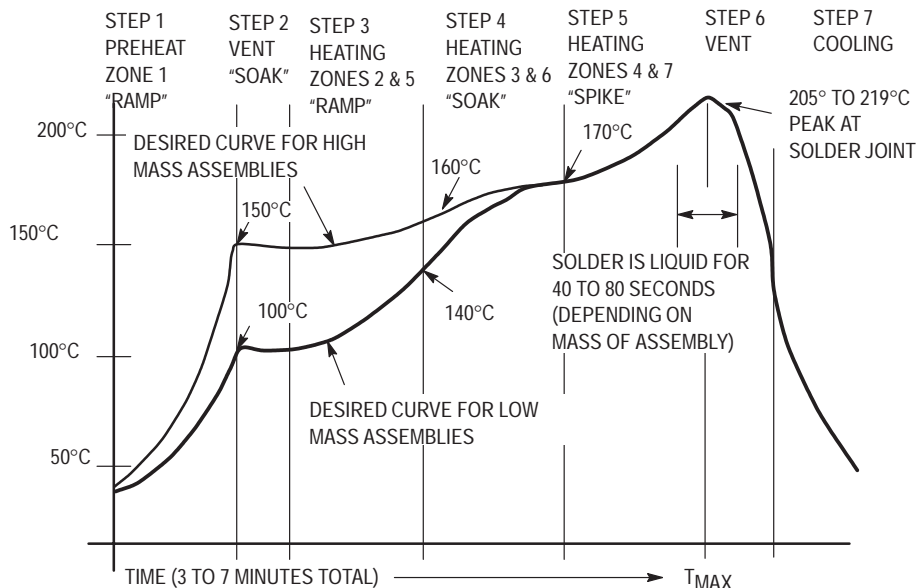
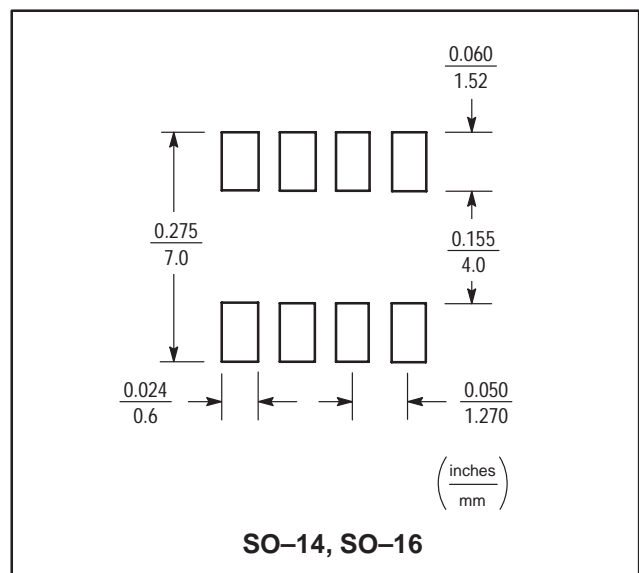
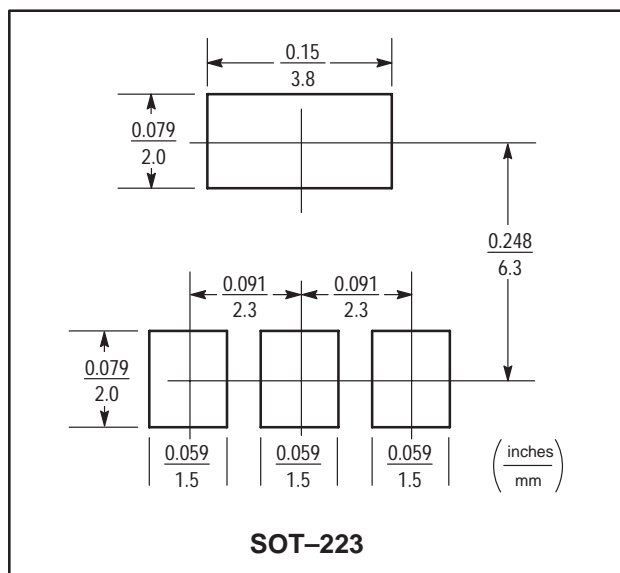
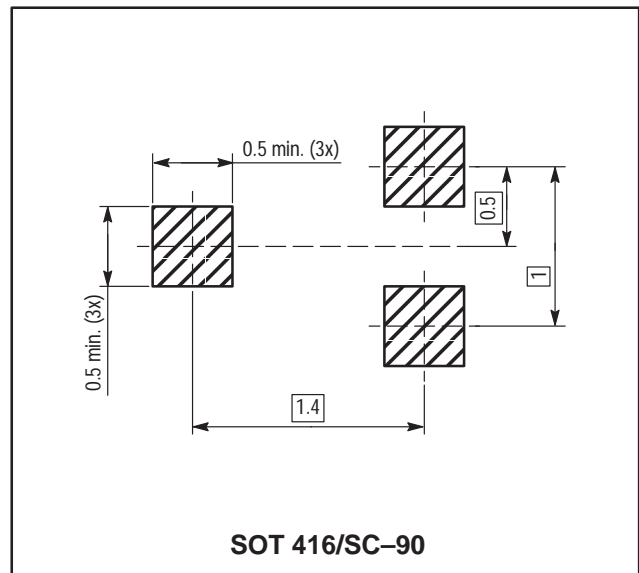
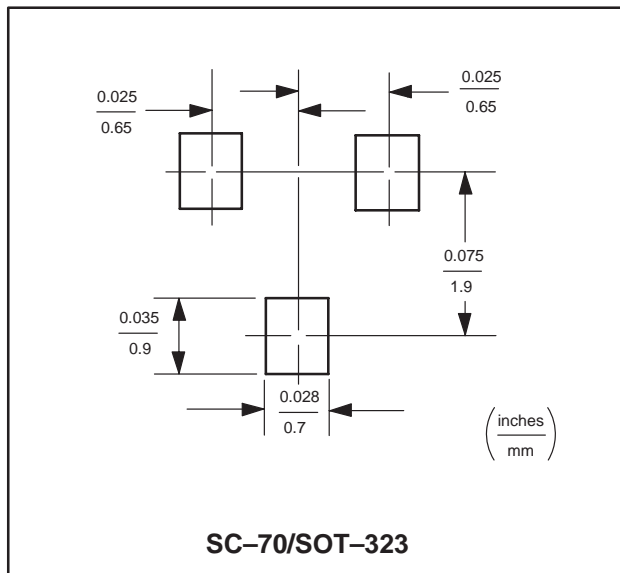
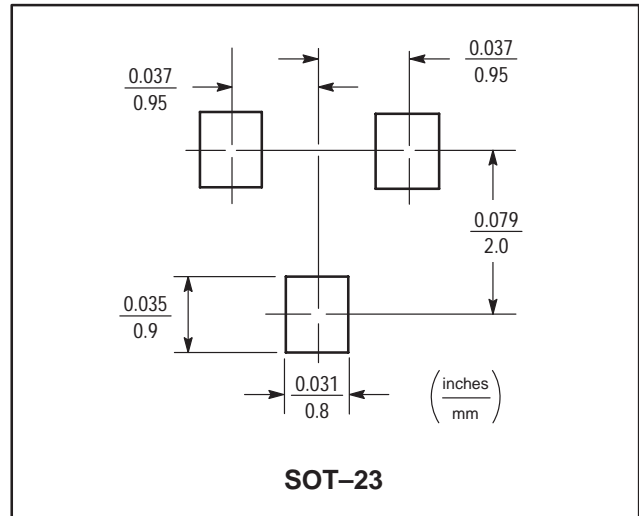
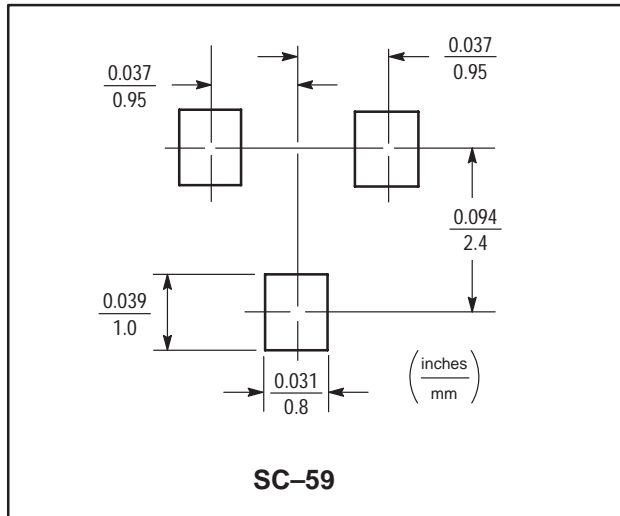
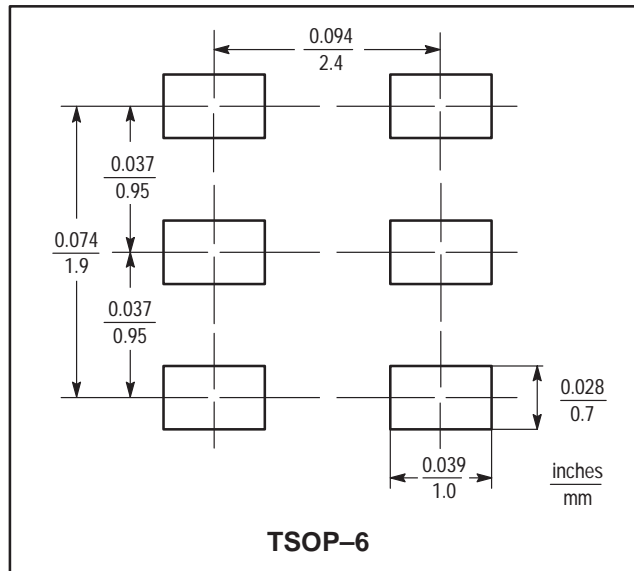
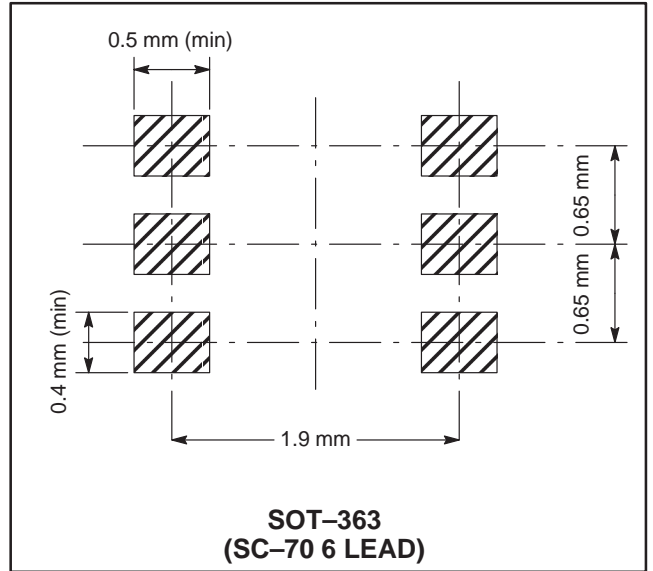
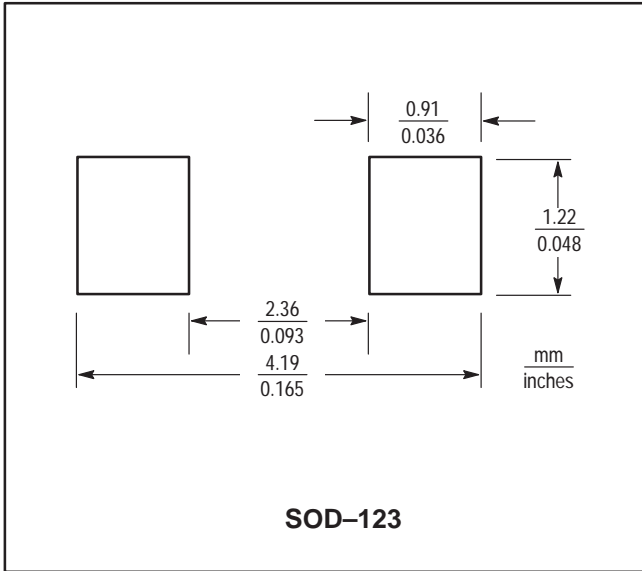

Figure 2. Typical Solder Heating Profile

Footprints for Soldering





Package Outline Dimensions

Dimensions are in inches unless otherwise noted.

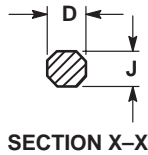
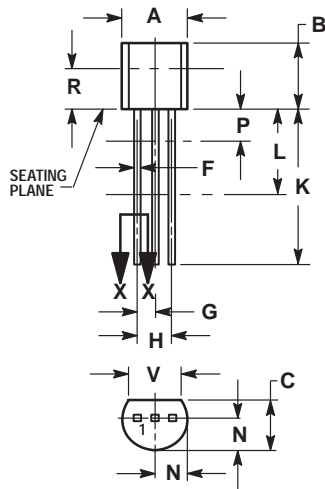

NOTES:

1. DIMENSIONING AND TOLERANCING PER ANSI Y14.5M, 1982.
2. CONTROLLING DIMENSION: INCH.
3. CONTOUR OF PACKAGE BEYOND DIMENSION R IS UNCONTROLLED.
4. DIMENSION F APPLIES BETWEEN P AND L. DIMENSION D AND J APPLY BETWEEN L AND K MINIMUM. LEAD DIMENSION IS UNCONTROLLED IN P AND BEYOND DIMENSION K MINIMUM.

DIM	INCHES		MILLIMETERS	
	MIN	MAX	MIN	MAX
A	0.175	0.205	4.45	5.20
B	0.170	0.210	4.32	5.33
C	0.125	0.165	3.18	4.19
D	0.016	0.022	0.41	0.55
F	0.016	0.019	0.41	0.48
G	0.045	0.055	1.15	1.39
H	0.095	0.105	2.42	2.66
J	0.015	0.020	0.39	0.50
K	0.500	---	12.70	---
L	0.250	---	6.35	---
N	0.080	0.105	2.04	2.66
P	---	0.100	---	2.54
R	0.115	---	2.93	---
V	0.135	---	3.43	---

STYLE 1:
PIN 1. EMITTER
2. BASE
3. COLLECTOR

STYLE 2:
PIN 1. BASE
2. EMITTER
3. COLLECTOR

STYLE 3:
PIN 1. ANODE
2. ANODE
3. CATHODE

STYLE 4:
PIN 1. CATHODE
2. CATHODE
3. ANODE

STYLE 5:
PIN 1. DRAIN
2. SOURCE
3. GATE

STYLE 7:
PIN 1. SOURCE
2. DRAIN
3. GATE

STYLE 14:
PIN 1. EMITTER
2. COLLECTOR
3. BASE

STYLE 15:
PIN 1. ANODE 1
2. CATHODE
3. ANODE 2

STYLE 17:
PIN 1. COLLECTOR
2. BASE
3. EMITTER

STYLE 21:
PIN 1. COLLECTOR
2. EMITTER
3. BASE

STYLE 22:
PIN 1. SOURCE
2. GATE
3. DRAIN

STYLE 30:
PIN 1. DRAIN
2. GATE
3. SOURCE

CASE 029-04 (TO-226AA) TO-92 PLASTIC

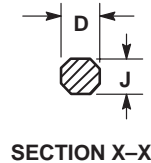
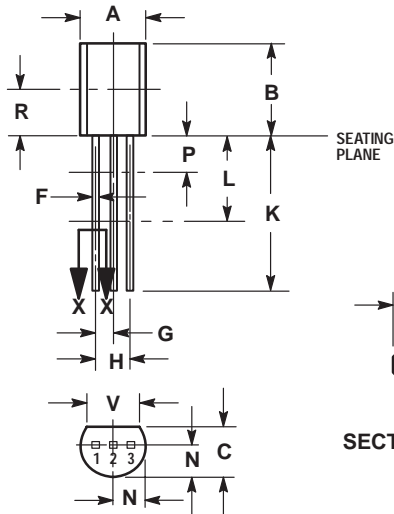

NOTES:

1. DIMENSIONING AND TOLERANCING PER ANSI Y14.5M, 1982.
2. CONTROLLING DIMENSION: INCH.
3. CONTOUR OF PACKAGE BEYOND DIMENSION R IS UNCONTROLLED.
4. DIMENSION F APPLIES BETWEEN P AND L. DIMENSIONS D AND J APPLY BETWEEN L AND K MINIMUM. LEAD DIMENSION IS UNCONTROLLED IN P AND BEYOND DIMENSION K MINIMUM.

DIM	INCHES		MILLIMETERS	
	MIN	MAX	MIN	MAX
A	0.175	0.205	4.44	5.21
B	0.290	0.310	7.37	7.87
C	0.125	0.165	3.18	4.19
D	0.018	0.022	0.46	0.56
F	0.016	0.019	0.41	0.48
G	0.045	0.055	1.15	1.39
H	0.095	0.105	2.42	2.66
J	0.018	0.024	0.46	0.61
K	0.500	---	12.70	---
L	0.250	---	6.35	---
N	0.080	0.105	2.04	2.66
P	---	0.100	---	2.54
R	0.135	---	3.43	---
V	0.135	---	3.43	---

STYLE 1:
PIN 1. EMITTER
2. BASE
3. COLLECTOR

STYLE 14:
PIN 1. EMITTER
2. COLLECTOR
3. BASE

STYLE 22:
PIN 1. SOURCE
2. GATE
3. DRAIN

CASE 029-05 (TO-226AE) TO-92 1-WATT PLASTIC

PACKAGE OUTLINE DIMENSIONS (continued)

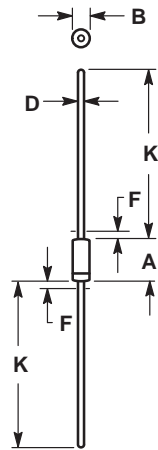

NOTES:

1. PACKAGE CONTOUR OPTIONAL WITHIN DIA B AND LENGTH A. HEAT SLUGS, IF ANY, SHALL BE INCLUDED WITHIN THIS CYLINDER, BUT SHALL NOT BE SUBJECT TO THE MIN LIMIT OF DIA B.
2. LEAD DIA NOT CONTROLLED IN ZONES F, TO ALLOW FOR FLASH, LEAD FINISH BUILDUP, AND MINOR IRREGULARITIES OTHER THAN HEAT SLUGS.

DIM	MILLIMETERS		INCHES	
	MIN	MAX	MIN	MAX
A	5.84	7.62	0.230	0.300
B	2.16	2.72	0.085	0.107
D	0.46	0.56	0.018	0.022
F	---	1.27	---	0.050
K	25.40	38.10	1.000	1.500

All JEDEC dimensions and notes apply.

CASE 51-02
(DO-204AA)
DO-7

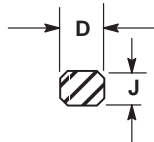
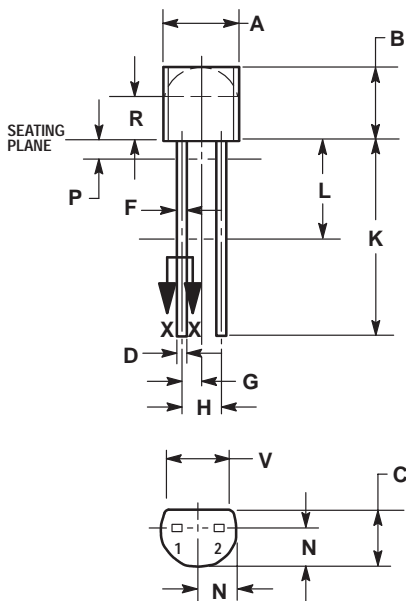

SECTION X-X

NOTES:

1. DIMENSIONING AND TOLERANCING PER ANSI Y14.5M, 1982.
2. CONTROLLING DIMENSION: INCH.
3. CONTOUR OF PACKAGE BEYOND ZONE R IS UNCONTROLLED.
4. DIMENSION F APPLIES BETWEEN P AND L. DIMENSIONS D AND J APPLY BETWEEN L AND K MINIMUM. LEAD DIMENSION IS UNCONTROLLED IN P AND BEYOND DIM K MINIMUM.

DIM	INCHES		MILLIMETERS	
	MIN	MAX	MIN	MAX
A	0.175	0.205	4.45	5.21
B	0.170	0.210	4.32	5.33
C	0.125	0.165	3.18	4.49
D	0.016	0.022	0.41	0.56
F	0.016	0.019	0.407	0.482
G	0.050 BSC		1.27 BSC	
H	0.100 BSC		3.54 BSC	
J	0.014	0.016	0.36	0.41
K	0.500	---	12.70	---
L	0.250	---	6.35	---
N	0.080	0.105	2.03	2.66
P	---	0.050	---	1.27
R	0.115	---	2.93	---
V	0.135	---	3.43	---

STYLE 1:
PIN 1. ANODE
2. CATHODE

CASE 182-02
(T0-226AC) TO-92
PLASTIC

PACKAGE OUTLINE DIMENSIONS (continued)

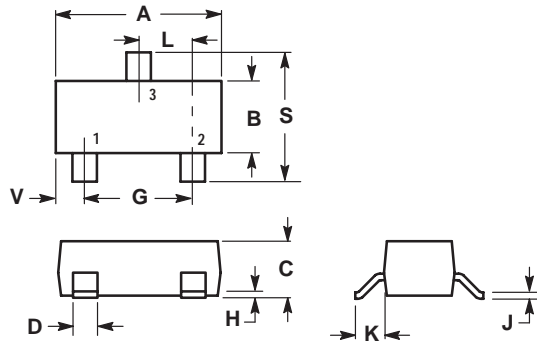

- NOTES:
1. DIMENSIONING AND TOLERANCING PER ANSI Y14.5M, 1982.
 2. CONTROLLING DIMENSION: INCH.
 3. MAXIMUM LEAD THICKNESS INCLUDES LEAD FINISH THICKNESS. MINIMUM LEAD THICKNESS IS THE MINIMUM THICKNESS OF BASE MATERIAL.

DIM	INCHES		MILLIMETERS	
	MIN	MAX	MIN	MAX
A	0.1102	0.1197	2.80	3.04
B	0.0472	0.0551	1.20	1.40
C	0.0350	0.0440	0.89	1.11
D	0.0150	0.0200	0.37	0.50
G	0.0701	0.0807	1.78	2.04
H	0.0005	0.0040	0.013	0.100
J	0.0034	0.0070	0.085	0.177
K	0.0140	0.0285	0.35	0.69
L	0.0350	0.0401	0.89	1.02
S	0.0830	0.1039	2.10	2.64
V	0.0177	0.0236	0.45	0.60

STYLE 6:
PIN 1. BASE
2. EMITTER
3. COLLECTOR

STYLE 8:
PIN 1. ANODE
2. NO CONNECTION
3. CATHODE

STYLE 9:
PIN 1. ANODE
2. ANODE
3. CATHODE

STYLE 10:
PIN 1. DRAIN
2. SOURCE
3. GATE

STYLE 11:
PIN 1. ANODE
2. CATHODE
3. CATHODE-ANODE

STYLE 12:
PIN 1. CATHODE
2. CATHODE
3. ANODE

STYLE 18:
PIN 1. NO CONNECTION
2. CATHODE
3. ANODE

STYLE 19:
PIN 1. CATHODE
2. ANODE
3. CATHODE-ANODE

STYLE 21:
PIN 1. GATE
2. SOURCE
3. DRAIN

**CASE 318-08
(TO-236AB) SOT-23
PLASTIC**

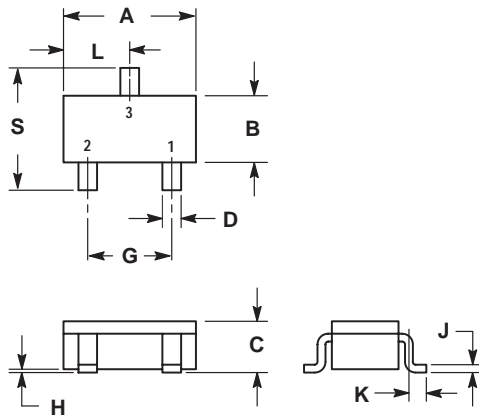

- NOTES:
1. DIMENSIONING AND TOLERANCING PER ANSI Y14.5M, 1982.
 2. CONTROLLING DIMENSION: MILLIMETER.

DIM	MILLIMETERS		INCHES	
	MIN	MAX	MIN	MAX
A	2.70	3.10	0.1063	0.1220
B	1.30	1.70	0.0512	0.0669
C	1.00	1.30	0.0394	0.0511
D	0.35	0.50	0.0138	0.0196
G	1.70	2.10	0.0670	0.0826
H	0.013	0.100	0.0005	0.0040
J	0.09	0.18	0.0034	0.0070
K	0.20	0.60	0.0079	0.0236
L	1.25	1.65	0.0493	0.0649
S	2.50	3.00	0.0985	0.1181

STYLE 1:
PIN 1. EMITTER
2. BASE
3. COLLECTOR

STYLE 2:
PIN 1. N.C.
2. ANODE
3. CATHODE

STYLE 3:
PIN 1. ANODE
2. ANODE
3. CATHODE

STYLE 4:
PIN 1. N.C.
2. CATHODE
3. ANODE

STYLE 5:
PIN 1. CATHODE
2. CATHODE
3. ANODE

**CASE 318D-04
SC-59**

PACKAGE OUTLINE DIMENSIONS (continued)

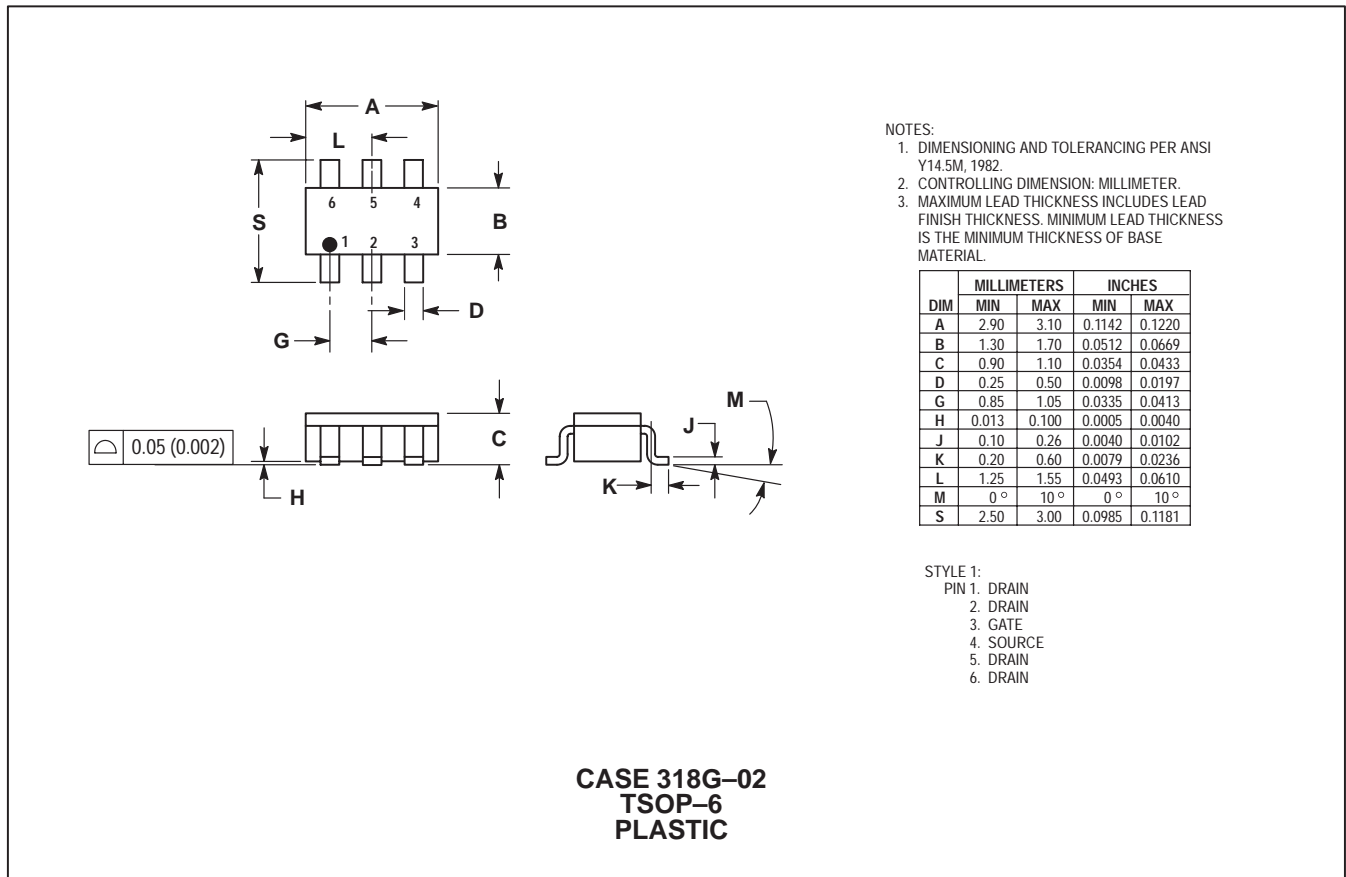
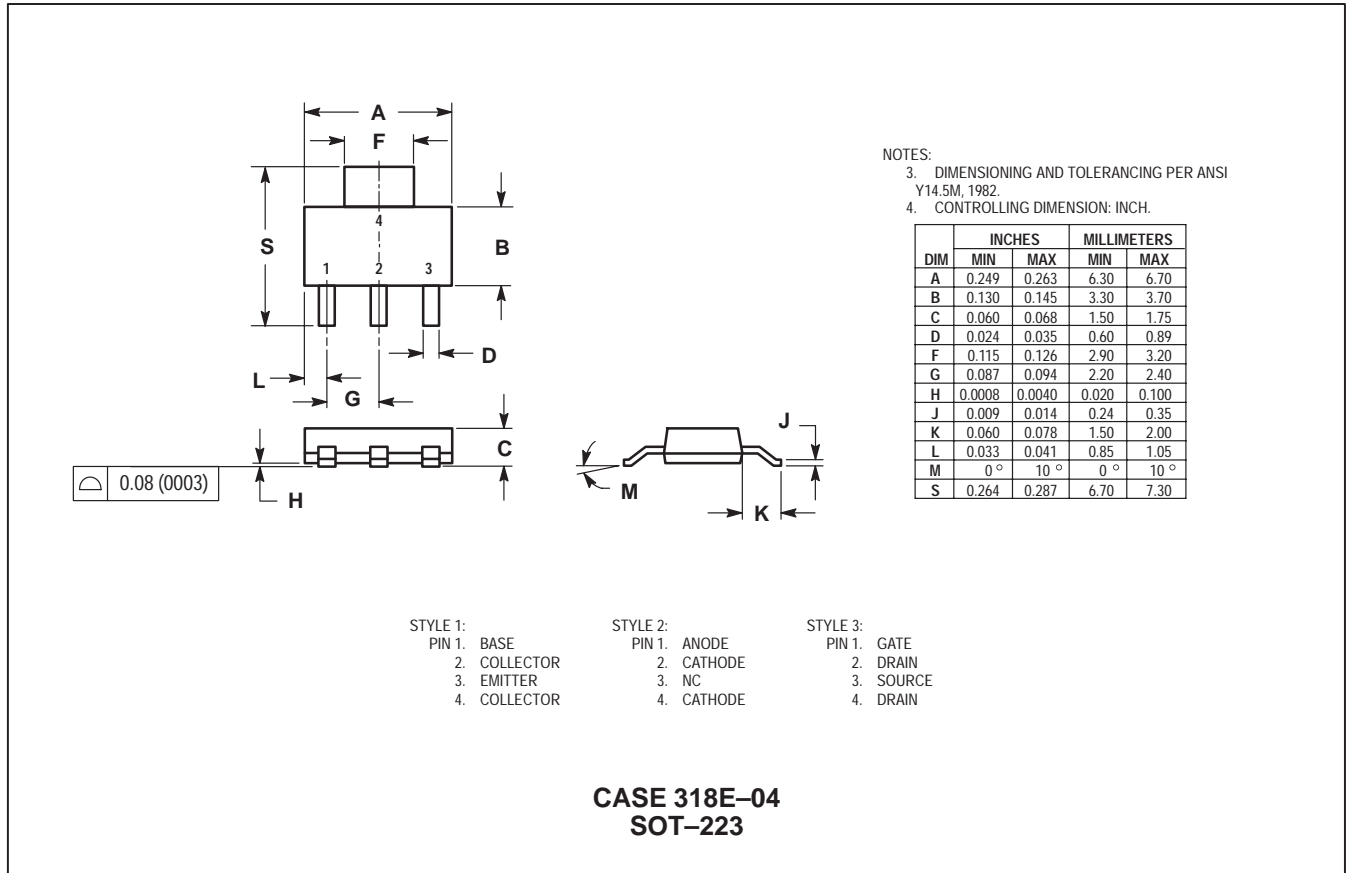

PACKAGE OUTLINE DIMENSIONS (continued)

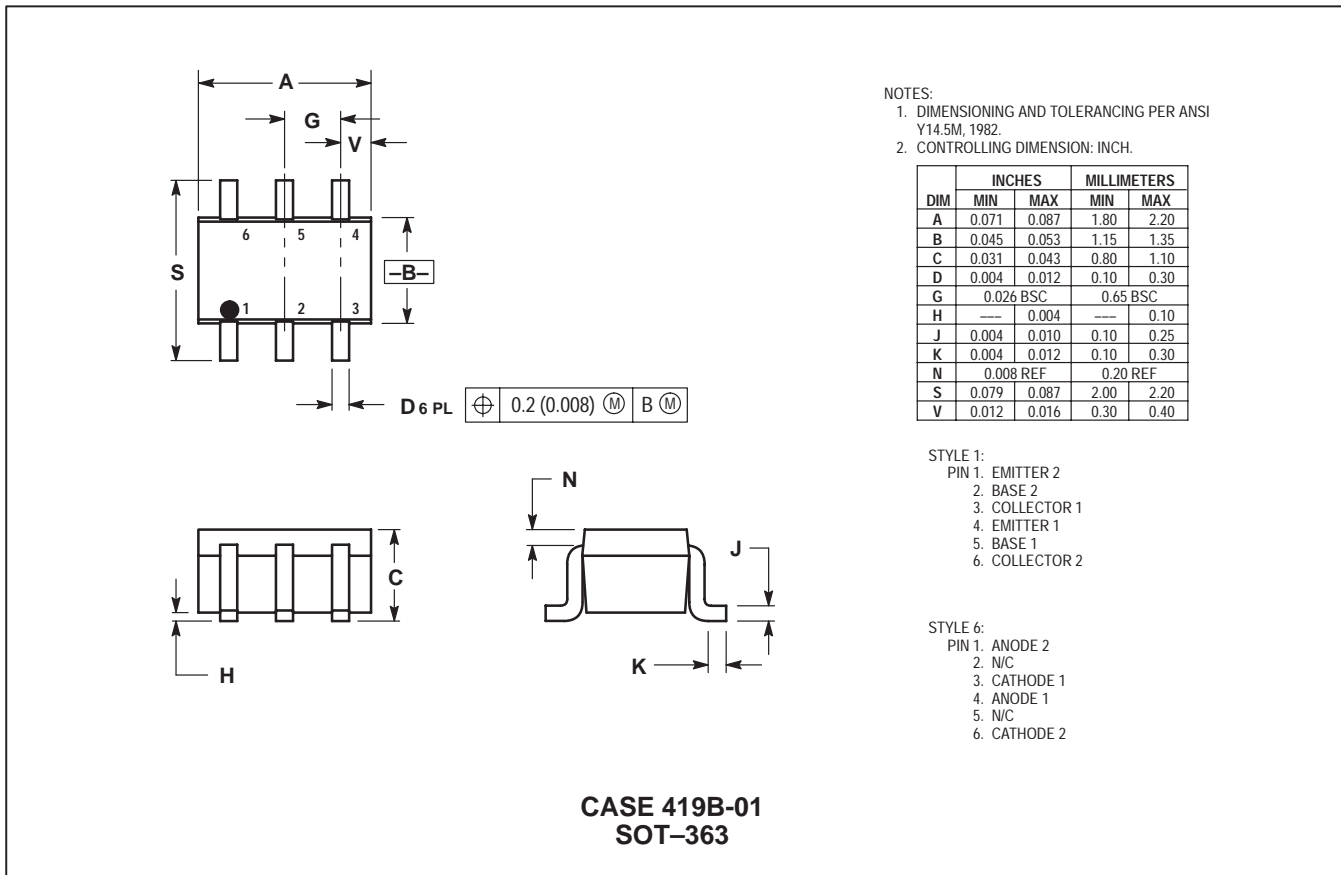
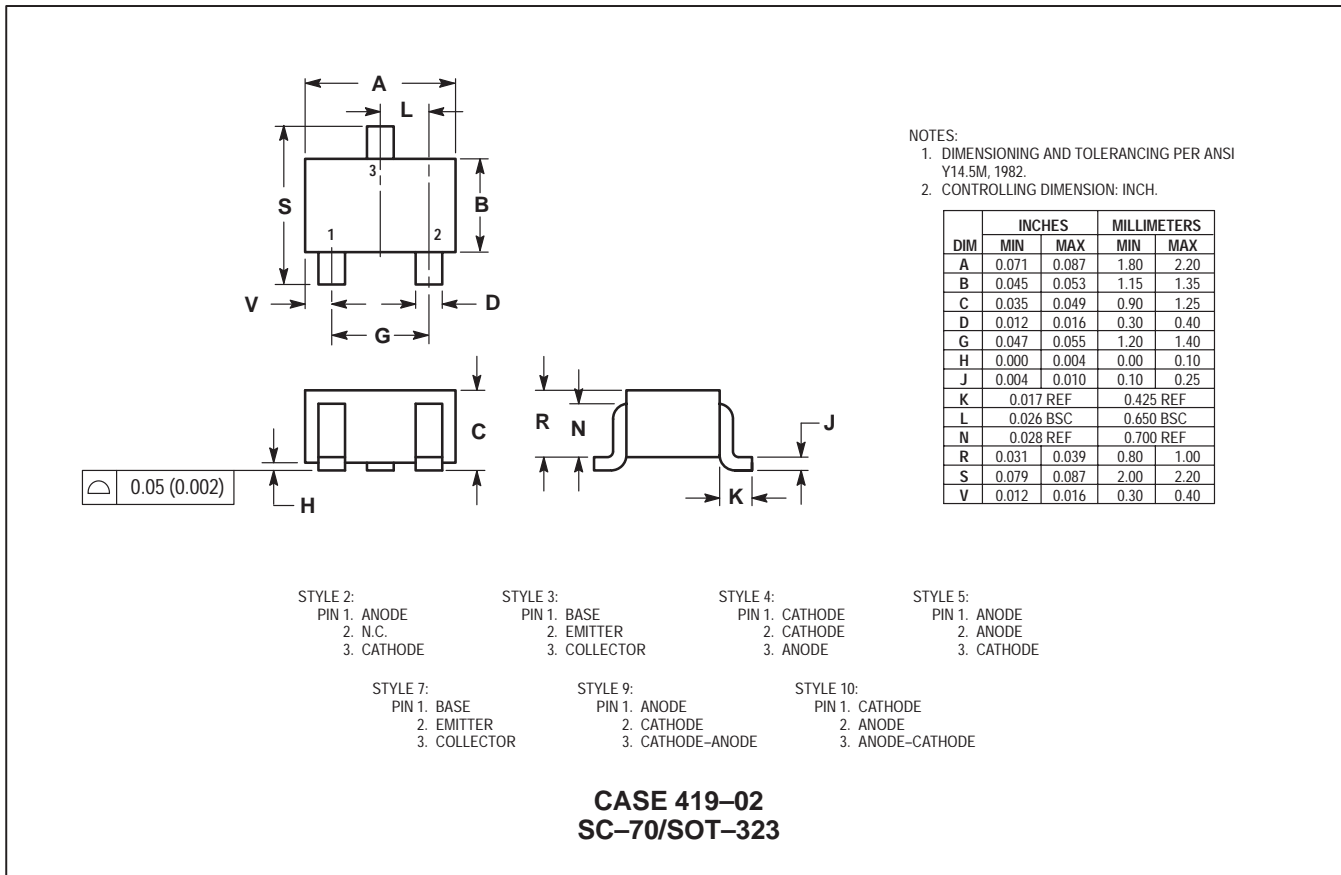

PACKAGE OUTLINE DIMENSIONS (continued)

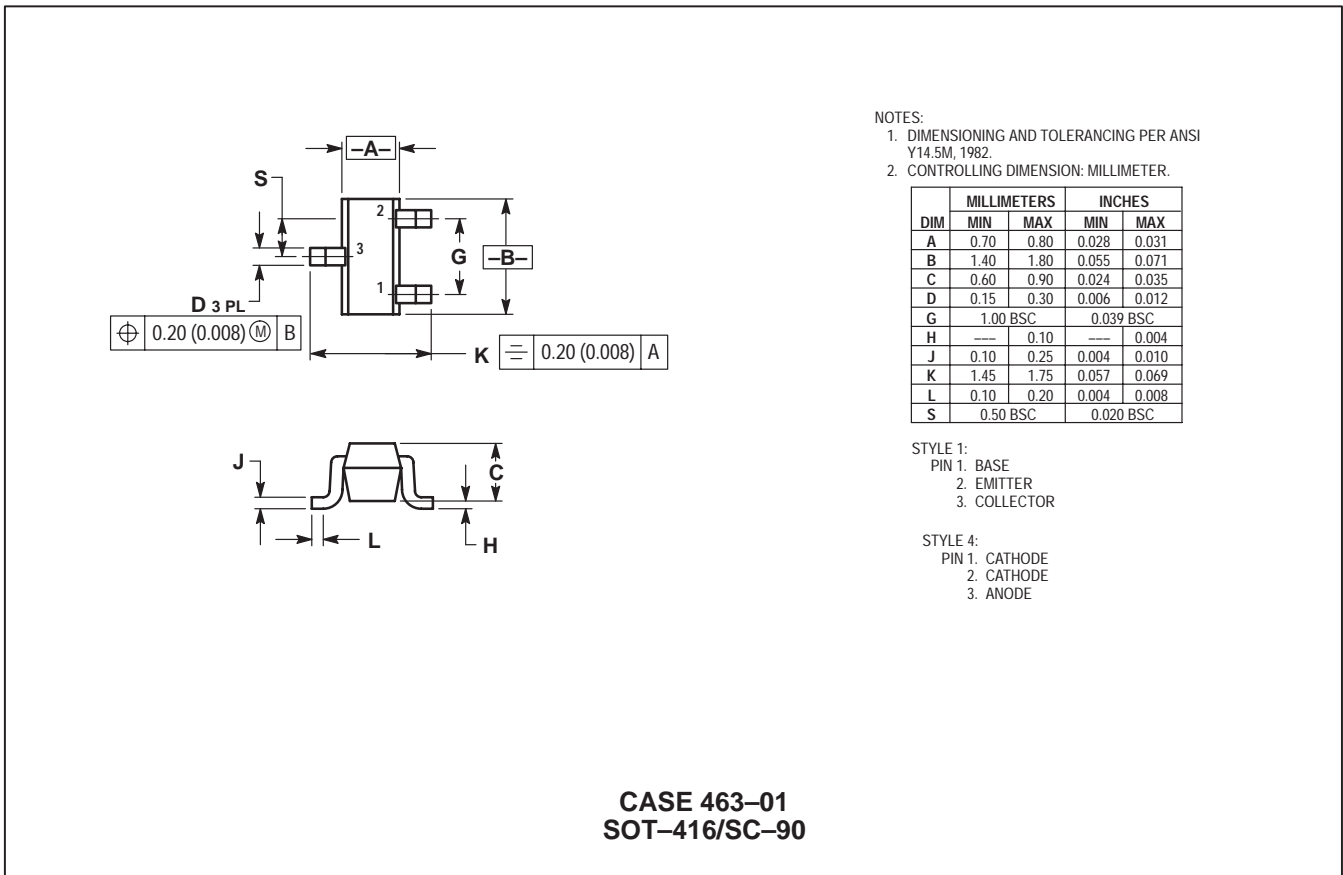
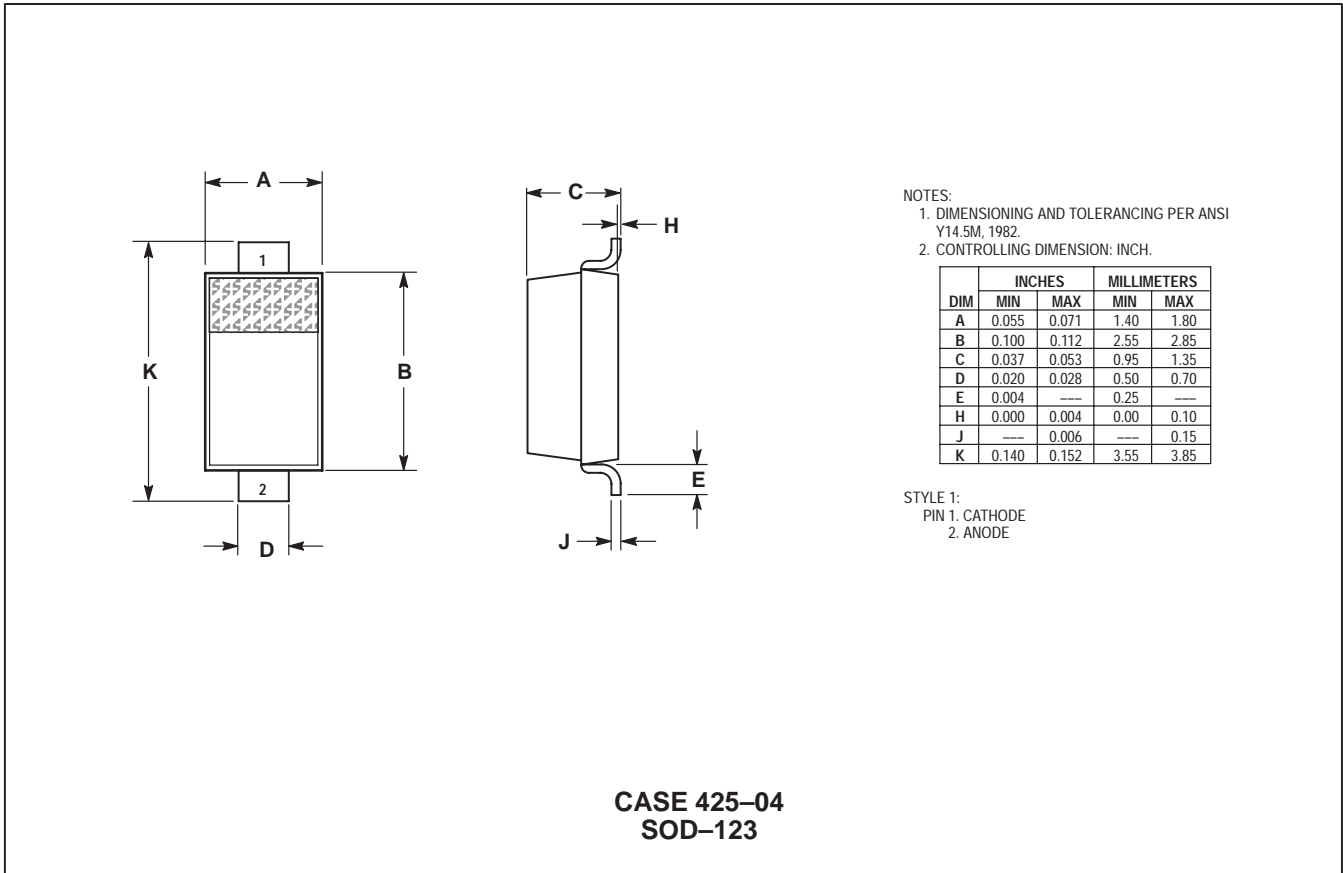

PACKAGE OUTLINE DIMENSIONS (continued)

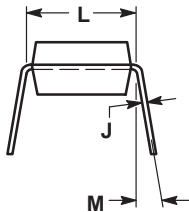
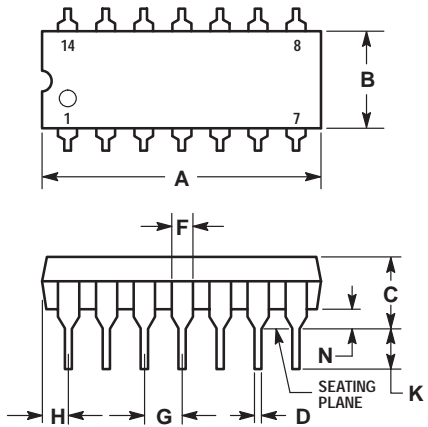

NOTES:

- LEADS WITHIN 0.13 (0.005) RADIUS OF TRUE POSITION AT SEATING PLANE AT MAXIMUM MATERIAL CONDITION.
- DIMENSION L TO CENTER OF LEADS WHEN FORMED PARALLEL.
- DIMENSION B DOES NOT INCLUDE MOLD FLASH.
- ROUNDED CORNERS OPTIONAL.

DIM	INCHES		MILLIMETERS	
	MIN	MAX	MIN	MAX
A	0.715	0.770	18.16	19.56
B	0.240	0.260	6.10	6.60
C	0.145	0.185	3.69	4.69
D	0.015	0.021	0.38	0.53
F	0.040	0.070	1.02	1.78
G	0.100 BSC		2.54 BSC	
H	0.052	0.095	1.32	2.41
J	0.008	0.015	0.20	0.38
K	0.115	0.135	2.92	3.43
L	0.300 BSC		7.62 BSC	
M	0° - 10°		0° - 10°	
N	0.015	0.039	0.39	1.01

CASE 646-06
14-PIN DIP
PLASTIC

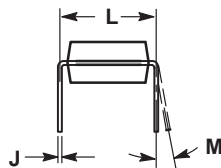
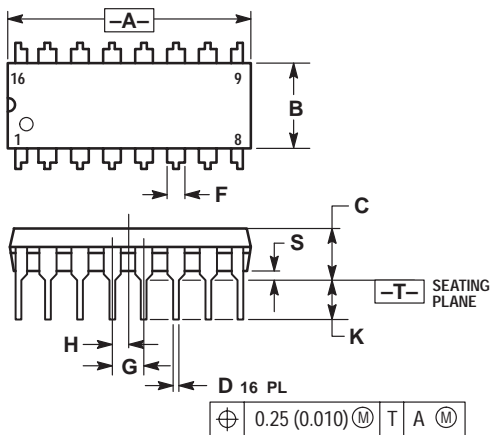

NOTES:

- DIMENSIONING AND TOLERANCING PER ANSI Y14.5M, 1982.
- CONTROLLING DIMENSION: INCH.
- DIMENSION L TO CENTER OF LEADS WHEN FORMED PARALLEL.
- DIMENSION B DOES NOT INCLUDE MOLD FLASH.
- ROUNDED CORNERS OPTIONAL.

DIM	INCHES		MILLIMETERS	
	MIN	MAX	MIN	MAX
A	0.740	0.770	18.80	19.55
B	0.250	0.270	6.35	6.85
C	0.145	0.175	3.69	4.44
D	0.015	0.021	0.39	0.53
F	0.040	0.70	1.02	1.77
G	0.100 BSC		2.54 BSC	
H	0.050 BSC		1.27 BSC	
J	0.008	0.015	0.21	0.38
K	0.110	0.130	2.80	3.30
L	0.295	0.305	7.50	7.74
M	0° - 10°		0° - 10°	
S	0.020	0.040	0.51	1.01

⊕	0.25 (0.010)	Ⓜ	T	A	Ⓜ
---	--------------	---	---	---	---

CASE 648-08
16-PIN DIP
PLASTIC

PACKAGE OUTLINE DIMENSIONS (continued)

