

**DESCRIPTION**

The LX1710/1711 is a monolithic high performance integrated class-D controller IC designed for high efficiency audio requirements such as portable or battery operated products, automotive amplifier, and multimedia applications. This high frequency, full audio bandwidth switching power amplifier controller, is a completely new design with dramatically improved performance over Linfinity's previous generation amplifier products. Enhancements include better SNR, lower noise floor, and reduced THD. Combined with output power MOSFET's and an output filter, the

LX1710/1711 is a complete class-D audio solution.

A complete audio amplifier module is available to quickly evaluate the LX1710 controller. Simply connect the amplifier to the power source, audio signal, and speakers. Reference designs support a variety of requirements including multi channel systems, subwoofers, and various speaker loads (2Ω, 4Ω, 8Ω). The versatile amplifier solution can easily be adjusted for frequency response, optimized for efficiency and performance, or designed to minimize PCB area and component count. The LX1710/LX1711 is available in a space saving 28-pin SSOP package.

**KEY FEATURES**

- Integrated Switching Class-D Single Channel Controller IC
- Full 20Hz-20kHz Audio Bandwidth
- High Fidelity (LX1710) Or High Power (LX1711) Versions Available
- Single Supply Operation
- THD+N <0.05% Typical (1Wrms, 1kHz, 4Ω)
- Maximum Efficiency 80%-85%
- Output Power >50Wrms (LX1711, 4Ω, 1% THD+N)
- PSRR -70dB Typical
- Differential Input To Minimize Noise Effects
- Supports Multi-Channel Systems
- Complete LX1710 Amplifier Evaluation Module Available
- 28-Pin SSOP Package

**IMPORTANT:** For the most current data, consult MICROSEMI's website: <http://www.microsemi.com>

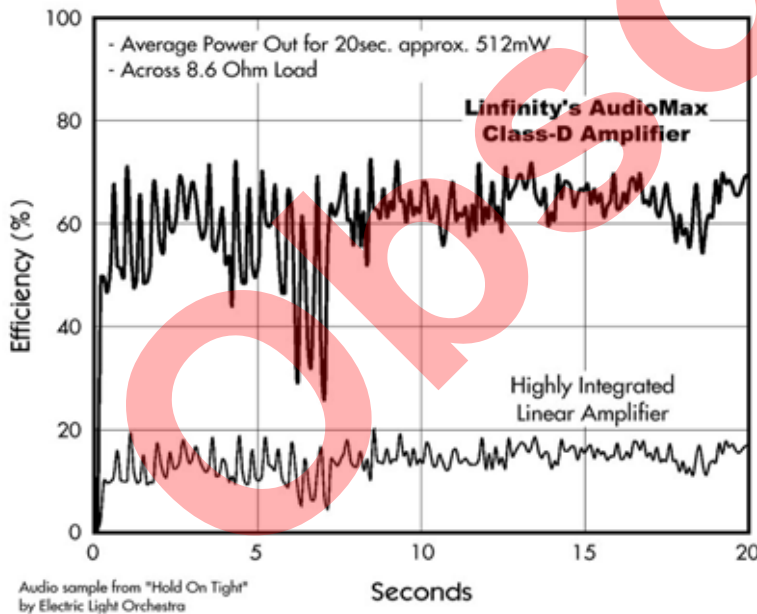
**PRODUCT HIGHLIGHT**
**Class-D Amplifier Efficiency Comparison**

**APPLICATIONS/BENEFITS**

- Notebook Computers
- Desktop Computers
- Multimedia Speakers
- Automotive Amplifiers And Headunits
- Battery Operated Equipment (Megaphone, PA System)
- Portable Audio (Boom Box)
- Wireless Speakers
- High Power Subwoofer

**PACKAGE ORDER INFO**

$T_J$ (°C)	$V_{DD}$	<b>DB</b> Plastic SSOP 28-PIN
-20 to 70	7V-15V	LX1710CDB
	7V-25V	LX1711CDB

**THERMAL DATA**
**DB**
**PACKAGE**
**THERMAL RESISTANCE-JUNCTION TO AMBIENT,  $\theta_{JA}$  50°C/W**

 Junction Temperature Calculation:  $T_J = T_A + (P_D \times \theta_{JA})$ .

 The  $\theta_{JA}$  numbers are guidelines for the thermal performance of the device/pc-board system. All of the above assume no ambient airflow.

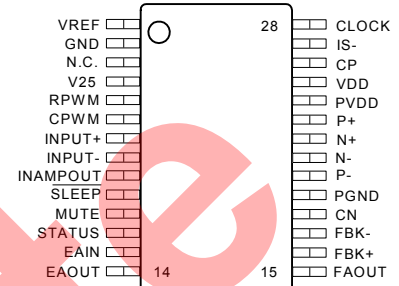
**PACKAGE PIN OUT**

**DESCRIPTION (CONTINUED)**

The mono output controller is available in either an LX1711 high power version (>50Wrms, 4Ω) with a supply voltage range of 7V-25V or an LX1710 high fidelity version (better SNR performance) with a supply voltage range of 7V-15V. The current rating of the external MOSFET's, the available supply voltage, and speaker load primarily limits the maximum output power. The amplifier provides high fidelity performance and it designed to operate over the full 20Hz to 20kHz audio band. Signal distortion measurements yield THD+N levels less than 0.05%

(1kHz, 1Wrms). Efficiency is greater than 80% typical, which eliminates the need for heatsinks, even at maximum output power.

The AudioMAX™ solution requires a single supply voltage, simplifying input power requirements where a dual supply may not be available. To minimize potential environmental noise issues and ease the integration of the amplifier into a variety of applications, features such as a balanced/differential audio input and a high power supply rejection ratio help reduce the effects of noise from the audio signal or power supply.

**FUNCTIONAL PIN DESCRIPTION**

Pin Name	Description	Pin Name	Description
VREF	5V Reference	FAOUT	Feedback Amplifier Output
GND	Low Current Ground	FBK+	Feedback Amplifier Non-Inverting Input
N.C.	No Connect	FBK-	Feedback Amplifier Inverting Input
V25	2.5V Reference	CN	Supply Decoupling for NFET Drivers
RPWM	PWM Resistor Connection	PGND	Output Driver High Current Ground
CPWM	PWM Capacitor Connection	P-	Drive for PFET on Negative Half of Bridge
INPUT+	Positive Audio Input	N-	Drive for NFET on Negative Half of Bridge
INPUT -	Negative Audio Input	N+	Drive for NFET on Positive Half of Bridge
INAMPOUT	Input Amplifier Output	P+	Drive for PFET on Positive Half of Bridge
SLEEP	Sleep Input (active low)	PVDD	Output Driver Supply Voltage
MUTE	Mute Input (active high)	VDD	Analog Supply Voltage
STATUS	UVLO Indicator (Open Collector Output)	CP	Supply Decoupling for PFET Drivers
EAIN	Inverting Input of Error Amplifier	IS -	Current Limit Sense Input
EAOUT	Error Amplifier Output	CLOCK	Input / Output Clock for Synch Operation

**ABSOLUTE MAXIMUM RATINGS**

Supply Voltage (PVDD, VDD) .....	-0.3V to 30V
SLEEP, STATUS, FBK+, FBK- .....	-0.3V to V <sub>DD</sub> +0.3V
IS- .....	PV <sub>DD</sub> -2 to PV <sub>DD</sub> to +0.3V
RPWM, CPWM, MUTE .....	-0.3V to V <sub>REF</sub> +0.3V
INPUT +, INPUT -, INAMPOUT .....	-0.3V to V <sub>REF</sub> +0.3V
EAIN, EAOUT, FAOUT .....	-0.3V to V <sub>REF</sub> +0.3V
CLOCK .....	-0.3V to C <sub>N</sub> +0.3V
Operating Junction Temperature Plastic (DB Package) .....	125°C
Storage Temperature Range .....	-65°C to 150°C
Lead Temperature (Soldering, 10 seconds) .....	300°C

Note 1: Exceeding these ratings could cause damage to the device. All voltages are with respect to Ground. Currents are positive into, negative out of the specified terminal.

**ELECTRICAL CHARACTERISTICS**

Unless otherwise specified, the following specifications apply over the operating ambient temperature -20°C < TA < 70°C (NOTE 2).  
 Test conditions: RPWM = 49.9k, CPWM = 100pF, VDD = PVDD = 15V

Parameter	Symbol	Test Conditions	LX1710 / 1711			Units
			Min	Typ.	Max	
<b>Evaluation Module (See Figure 2)</b>						
Supply Voltage	LX1710	V <sub>DD</sub>	7		15	V
	LX1711		7		25	
Power Supply Rejection Ratio	PSRR	V <sub>IN</sub> = 15V, V <sub>RIPPLE</sub> = 1V <sub>RMS</sub> , 10Hz to 10kHz		-70		dB
Output Power	P <sub>O</sub>	V <sub>IN</sub> = 15V, R <sub>L</sub> = 4Ω, THD+N=1%, 10Hz to 22kHz		25		W
		V <sub>IN</sub> = 25V, R <sub>L</sub> = 4Ω, THD+N=1%, 10Hz to 22kHz		54		
Efficiency		V <sub>IN</sub> = 15V, f <sub>IN</sub> = 1kHz, P <sub>O</sub> = 10W		82		%
		V <sub>IN</sub> = 15V, f <sub>IN</sub> = 1kHz, P <sub>O</sub> = 20W		85		
Total Harmonic Distortion Plus Noise	THD+N	f <sub>IN</sub> = 1kHz, P <sub>O</sub> = 1W		.05		%
		f <sub>IN</sub> = 20Hz to 20kHz, P <sub>O</sub> = 1W			.3	
Signal-To-Noise Ratio	SNR	R <sub>L</sub> = 4Ω, P <sub>O</sub> = 1W		81		dBr
<b>Oscillator Section</b>						
Oscillator Frequency	F <sub>OSC</sub>			335		kHz
Charge Current	I <sub>CHG</sub>	(varies with V <sub>DD</sub> pin voltage)		-110		μA
Discharge Current	I <sub>DIS</sub>	(varies with V <sub>DD</sub> pin voltage)		110		μA
Oscillator Peak Voltage	V <sub>PK</sub>	(varies with V <sub>DD</sub> pin voltage)		3.4		V
Oscillator Valley Voltage	V <sub>VAL</sub>	(varies with V <sub>DD</sub> pin voltage)		1.6		V
Voltage Stability		V <sub>DD</sub> = 8V to 25V		0.6	2	%
		T <sub>A</sub> = 0°C to 70°C		1.0	2	%
Temperature Stability		T <sub>A</sub> = -40°C to 125°C		1.5		%
<b>Error Amplifier</b>						
Input Offset Voltage	V <sub>IO</sub>			5		mV
DC Open Loop Gain	A <sub>OL</sub>			60		dB
Unity Gain Bandwidth	UGBW			7		mHz
High Output Voltage	V <sub>OH</sub>	I <sub>OUT</sub> = -100μA	V <sub>REF</sub> -1			V
Low Output Voltage	V <sub>OL</sub>	I <sub>OUT</sub> = +100μA			50	mV
Input Common Mode Range						
Input Bias Current	I <sub>IN</sub>	V <sub>IN</sub> = 1V to V <sub>REF</sub>			1	μA
<b>Input Amplifier</b>						
Stage Gain		Set by Internal Resistors	3.465	3.5	3.535	V/V
Output Voltage, High	V <sub>OH</sub>	I <sub>OUT</sub> = -100μA	3.85			V

**ELECTRICAL CHARACTERISTICS (CONTINUED)**

Parameter	Symbol	Test Conditions	LX1710 / 1711			Units
			Min	Typ.	Max	
Output Voltage, Low	$V_{OL}$	$I_{OUT} = +100\mu A$			1.3	mV
Input Impedance				42		k $\Omega$
<b>Feedback Amplifier</b>						
Stage Gain	LX1710	Set by Internal Resistors	89	91	93	mV/V
	LX1711	Set by Internal Resistors	56	57	58	mV/V
Input Impedance				388		k $\Omega$
<b>Current Limit Comparator</b>						
Voltage Sense Threshold			190	210	230	mV
Blanking Pulse Delay				500		ns
Response Time		Excluding blanking pulse		250		ns
$I_{UM}$ Pulses required to Current Limit Latch			9	9	9	cycles
Consecutive Clear Pulses required to reset $I_{UM}$ counter			2	2	2	cycles
<b>Reference Voltage Section</b>						
Initial Accuracy				5.000		
Voltage Stability				$\pm 25$	$\pm 50$	mV
Temperature Stability		$T_A = 0^\circ C$ to $70^\circ C$		2	5	mV
		$T_A = -40^\circ C$ to $125^\circ C$		4	10	mV
Line Regulation		$V_{DD} = 9V$ to $15V$		0.5		mV
Load Regulation		$I_{OUT} = 0$ to $20mA$		5		mV
<b>Under voltage Lockout Section</b>						
Start Threshold Voltage				6.5		V
UV Lockout Hysteresis			0.5	6.5		V
UVLO Delay To Output Enable				62,500		clkcy
<b>Supply Current</b>						
Sleep Current		SLEEP Input = 0V, $T_A = 25^\circ C$		25		$\mu A$
Operating Current		SLEEP Input = 2V, $V_{IN} = 15V$ , No MOSFETs connected		2.9	5.0	mA
Sleep to Output Enable				62,500		clkcy
Sleep Threshold			1.2	1.45	1.6	V
<b>Mute Section</b>						
Mute Threshold			1.6	1.7	1.8	V
<b>Output Drivers for N-Channel MOSFETs</b>						
NFET Drivers, Low Level Voltage	$V_{OL}$	$I_{SINK} = 3mA$		30	100	mV
		$I_{SINK} = 75mA$		1.5	2.0	V
NFET Drivers, High Level Voltage	$V_{OH}$	$I_{SOURCE} = 3mA$ , $C_N = 5.2V$ applied externally		30	100	mV
		$I_{SOURCE} = 75mA$ , $C_N = 5.2V$ applied externally		1.5	2.0	V
<b>Output Drives For P-Channel MOSFETs</b>						
PFET Drivers, Low Level Voltage	$V_{OL}$	$I_{SINK} = 3mA$		30	100	mV
		$I_{SINK} = 75mA$		1	1.5	V
PFET Drivers, High Level Voltage	$V_{OH}$	$I_{SOURCE} = 3mA$ , $C_P = 5.2V$ (applied externally)		30	100	mV
		$I_{SOURCE} = 75mA$ , $C_P = 5.2V$ (applied externally)		1	1.5	V

Note 2: The LX1710 / 11CDB is guaranteed to meet performance specifications from 0°C to 70°C. Specifications over the -20°C to 0°C operation temperature range are assured by design, characterization, and statistical process control.

**BLOCK DIAGRAM**

LX1710/11 SIMPLIFIED BLOCK DIAGRAM

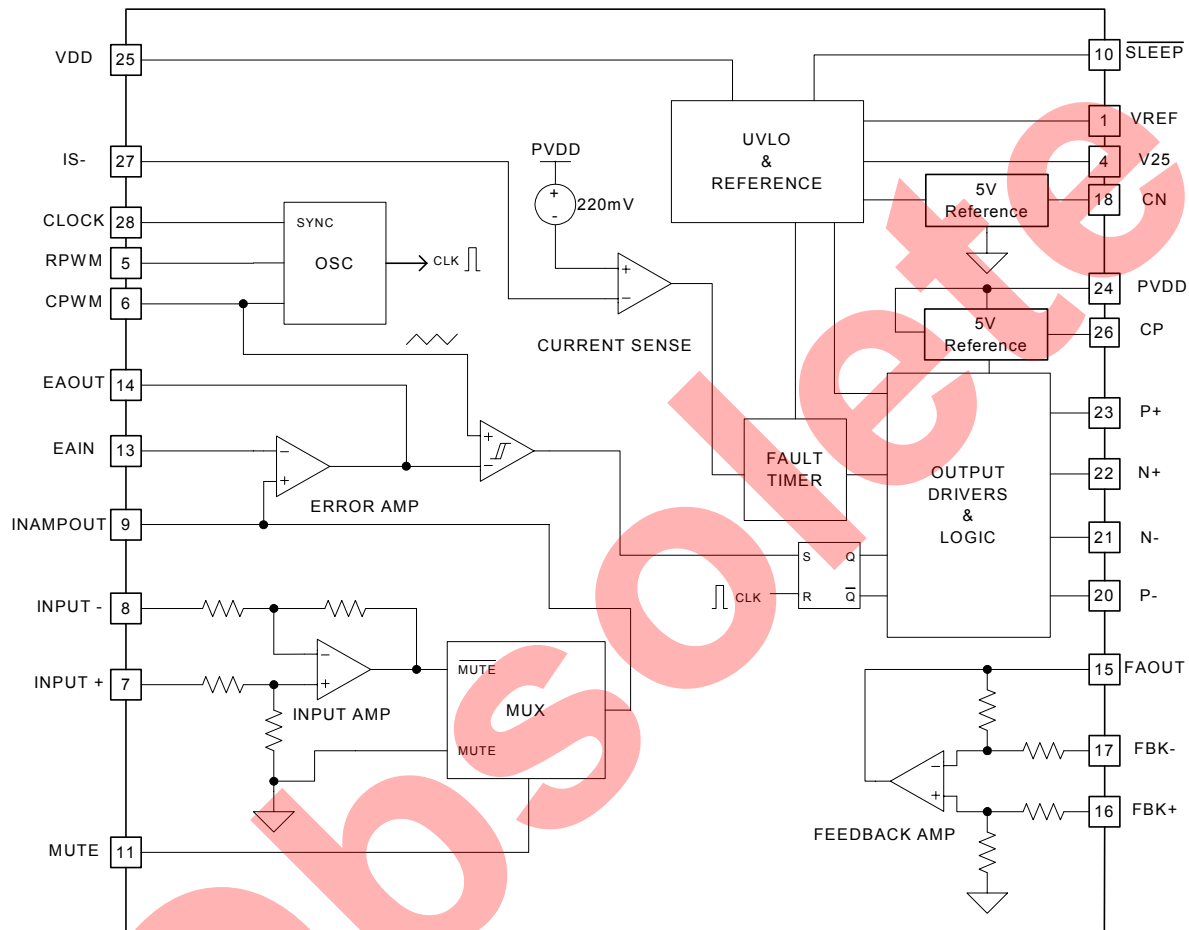
**Figure 1 - LX1710 Block Diagram**
**APPLICATION INFORMATION**
**Frequency Synchronization**

Two or more LX1710 / LX1711 oscillators can be configured for synchronous operation. One unit, the master, is programmed for the desired frequency with the  $R_{P_{PWM}}$  and  $C_{P_{PWM}}$  as usual. Additional units will be slave units, and their oscillators will be disabled by leaving the  $R_{P_{PWM}}$  pin disconnected. The CLOCK pin and the  $C_{P_{PWM}}$  pin of the slave units should be tied to the CLOCK pin and the  $C_{P_{PWM}}$  pin of the master unit respectively. In this configuration, the CLOCK pins of the slave units begin receiving instead of transmitting clock pulses. Also, the  $C_{P_{PWM}}$  pins quit driving the PWM capacitor in the slave units. Note that for optimum performance, all slave units should be located within a few inches of the master unit.

**Oscillator Configuration ( $R_{P_{PWM}}$  and  $C_{P_{PWM}}$  selection)**

The oscillator is programmed by the external timing components  $R_{P_{PWM}}$  and  $C_{P_{PWM}}$ . For a nominal frequency of 333kHz,  $R_{P_{PWM}}$  and  $C_{P_{PWM}}$  should be set to 49.9kOhms and 100pF respectively. Note that in order to keep the slope of the PWM ramp voltage proportional to the supply voltage; both the ramp peak and valley voltages, and the charge and discharge currents are proportional to the supply voltage. This keeps the frequency relatively constant while keeping the slope of the PWM ramp proportional to the voltage on the VDD pin. For operating frequencies other than 333kHz, the frequency can be approximated by the following equation:

$$\text{Frequency} = \frac{1}{(0.577)(R_{P_{PWM}})(C_{P_{PWM}}) + 320ns}$$

**TYPICAL APPLICATION**

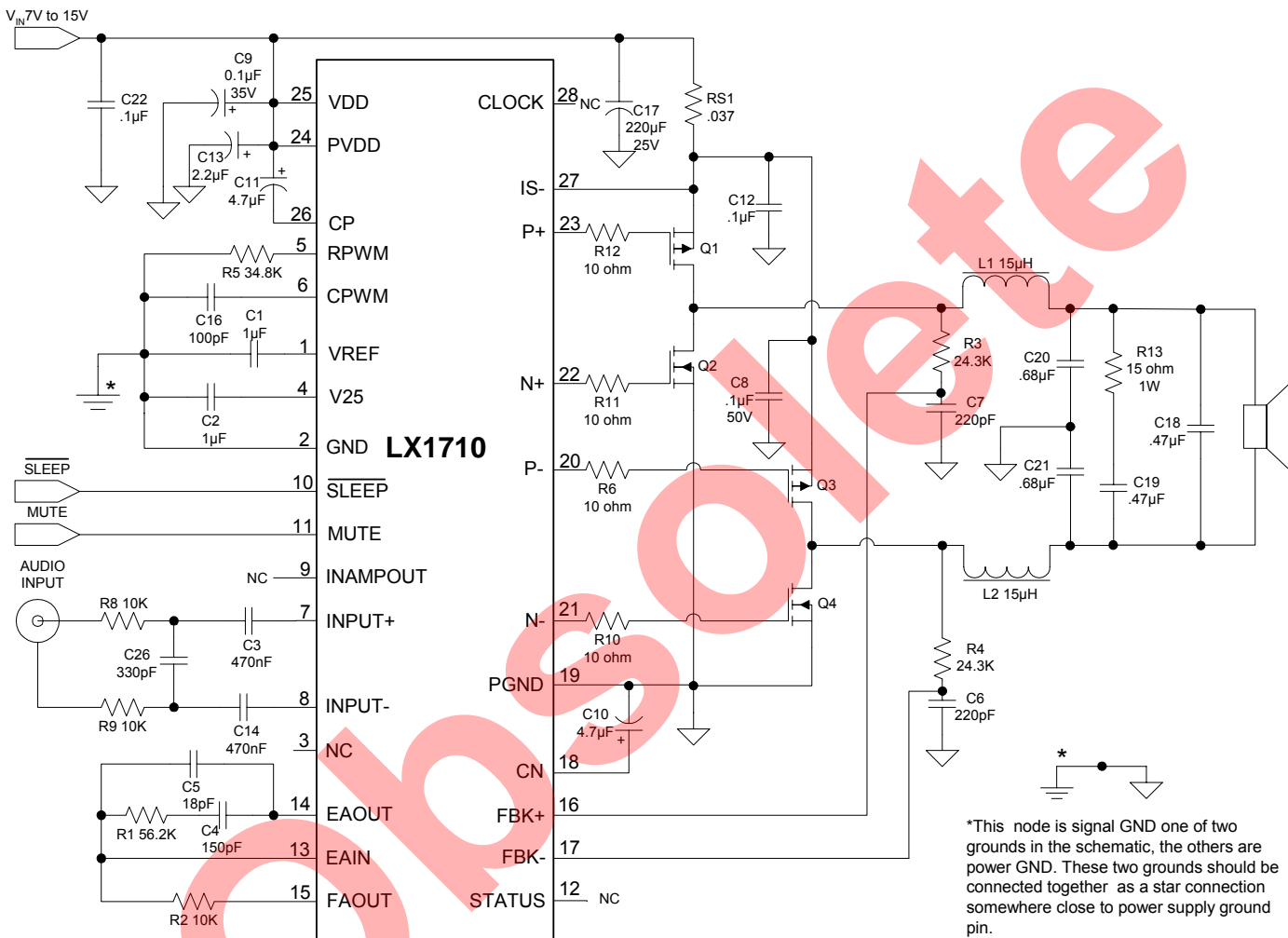

**Figure 2** – Typical Class-D Switching Amplifier Circuit Application

**THD+N VS. FREQUENCY**

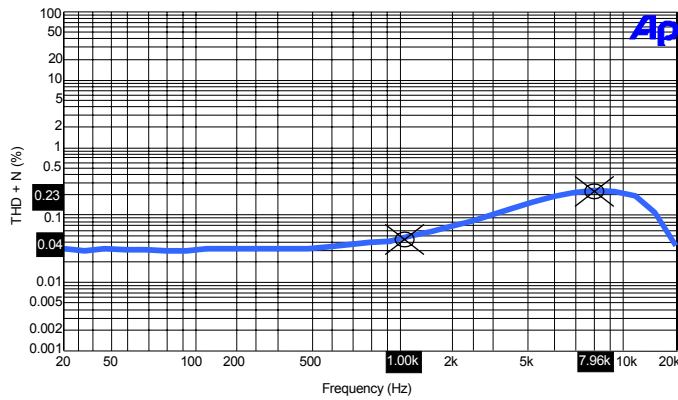

$V_{IN} = 15V$   
 $R_L = 4\Omega$   
 $P_O = 1W_{RMS}$

**THD+N VS. OUTPUT POWER**

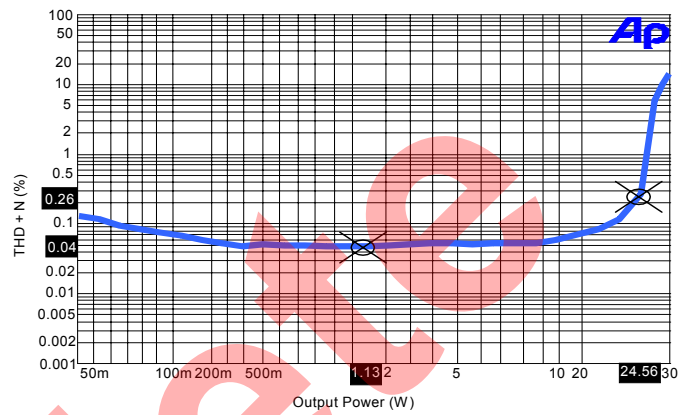

$V_{IN} = 15V$   
 $f_{IN} = 1\text{ kHz}$   
 $R_L = 4\Omega$

**FREQUENCY RESPONSE**

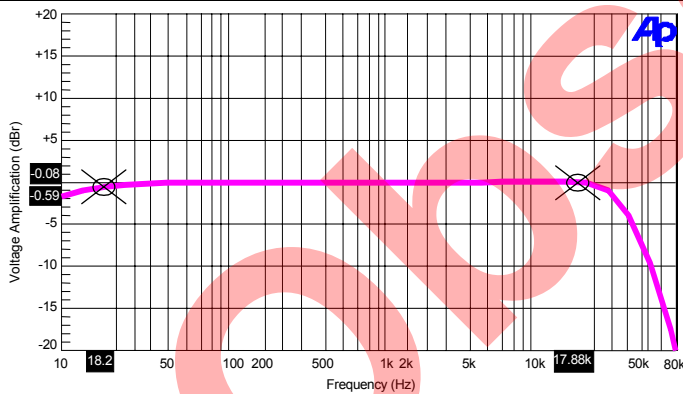

$V_{IN} = 15V$   
 $R_L = 4\Omega$   
 $P_O = 1W_{RMS}$

**POWER BAND**

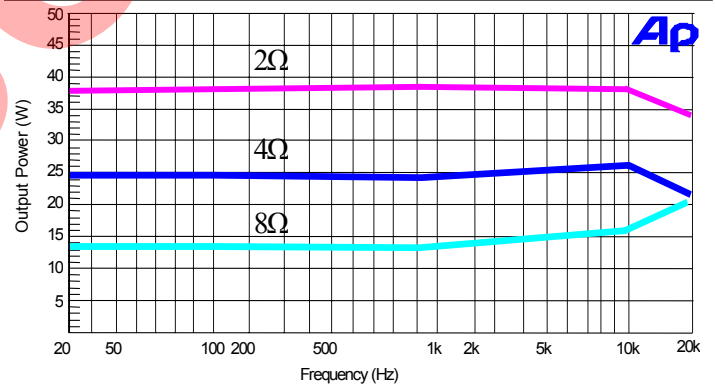

$V_{IN} = 15V$   
THD+N = 1%

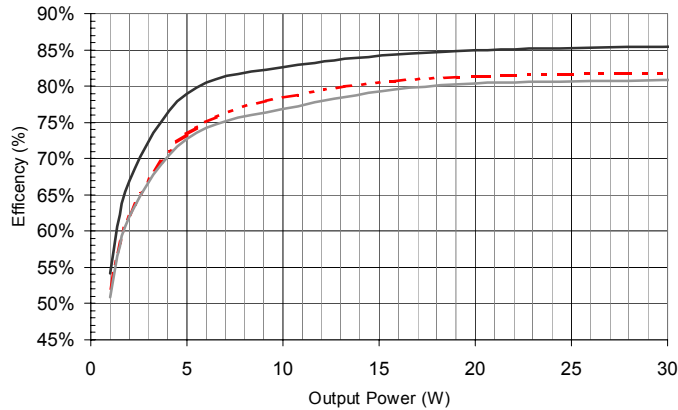
**EFFICIENCY VS. OUTPUT POWER**

 $V_{IN} = 15V$   
 $f_{IN} = 1kHz$ 

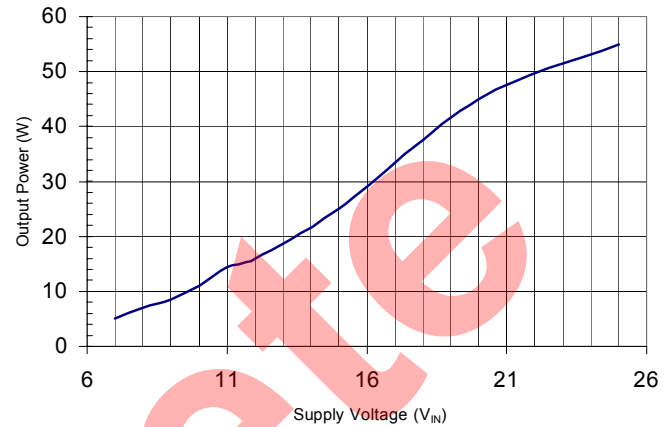
- - - 8Ω — 4Ω — 2Ω

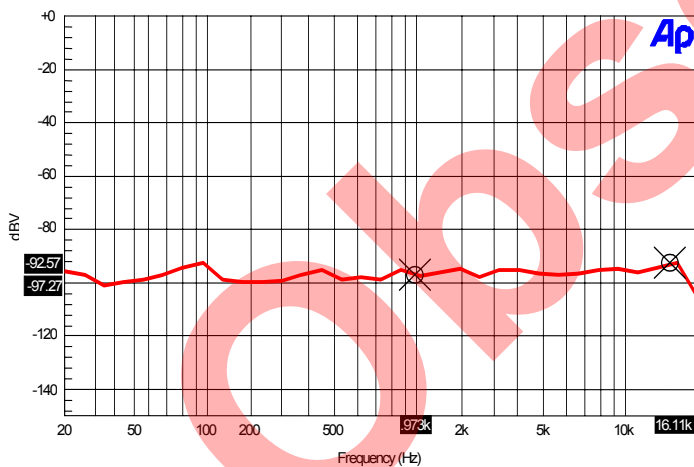
**OUTPUT POWER VS. SUPPLY VOLTAGE**

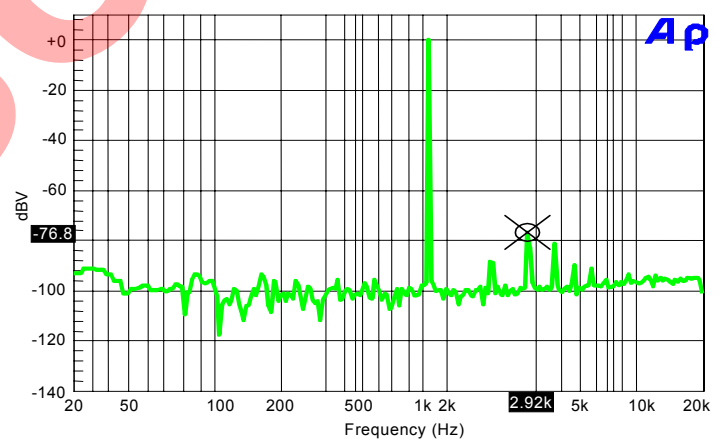
 $f_{IN} = 1kHz$   
 $R_L = 4\Omega$   
 THD+N = 1%

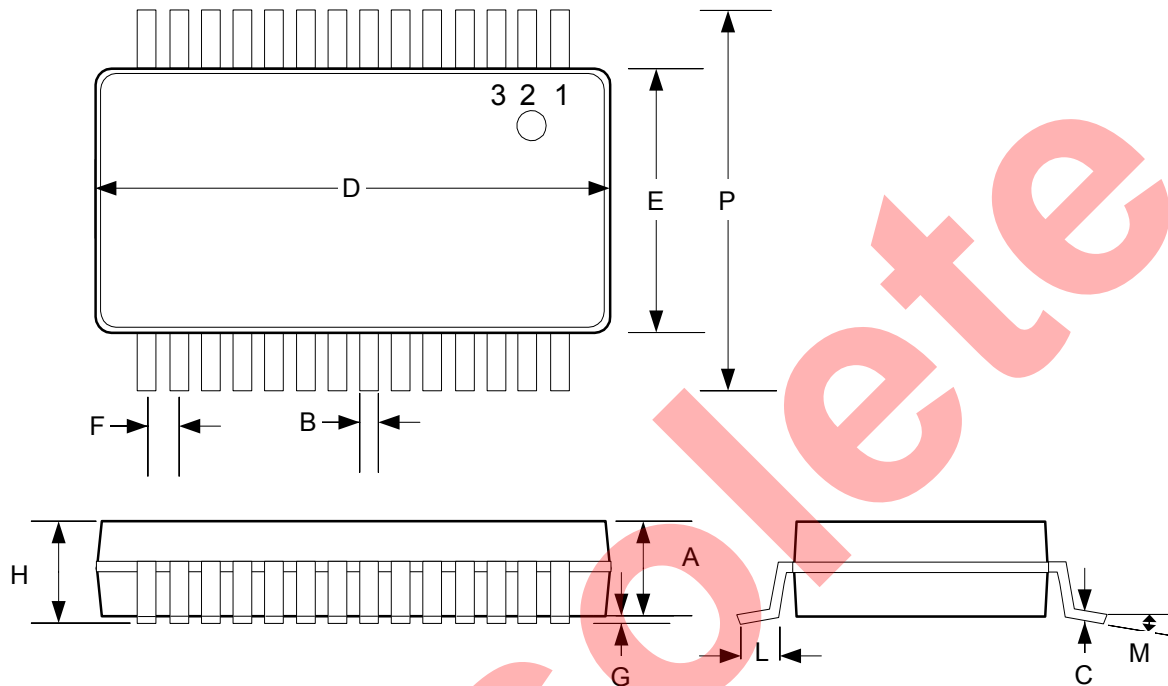
**NOISE FLOOR FFT**

 $V_{IN} = 15V$   
 $R_L = 4\Omega$   
 10Hz – 22 kHz Bandwidth  
 A - weighted

**OUTPUT SPECTRUM**

 $V_{IN} = 15V$   
 $R_L = 4\Omega$   
 $f_{IN} = 1kHz$   
 $P_O = 1W_{RMS}$   
 SNR = 81 dB  
 10Hz – 22kHz Bandwidth  
 A - weighted

**MECHANICAL DIMENSIONS**

DIM	Millimeters		Inches	
	MIN	MAX	MIN	MAX
A	1.65	1.85	0.065	0.073
B	0.25	0.38	0.009	0.015
C	0.13	0.22	0.005	0.008
D	9.90	10.50	0.390	0.413
E	5.00	5.60	0.197	0.221
F	0.65 BSC		.025 BSC	
G	0.05	0.21	0.002	0.008
H	1.73	2.00	0.068	0.078
L	0.65	0.95	0.025	0.037
M	0°	8°	0°	8°
P	7.65	7.90	0.301	0.311
*LC		0.10		0.004

\*Lead Coplanarity

## Note:

- Dimensions do not include mold flash or protrusions; these shall not exceed 0.15mm (.006") on any side. Lead dimension shall not include solder coverage.