

TOP VIEW

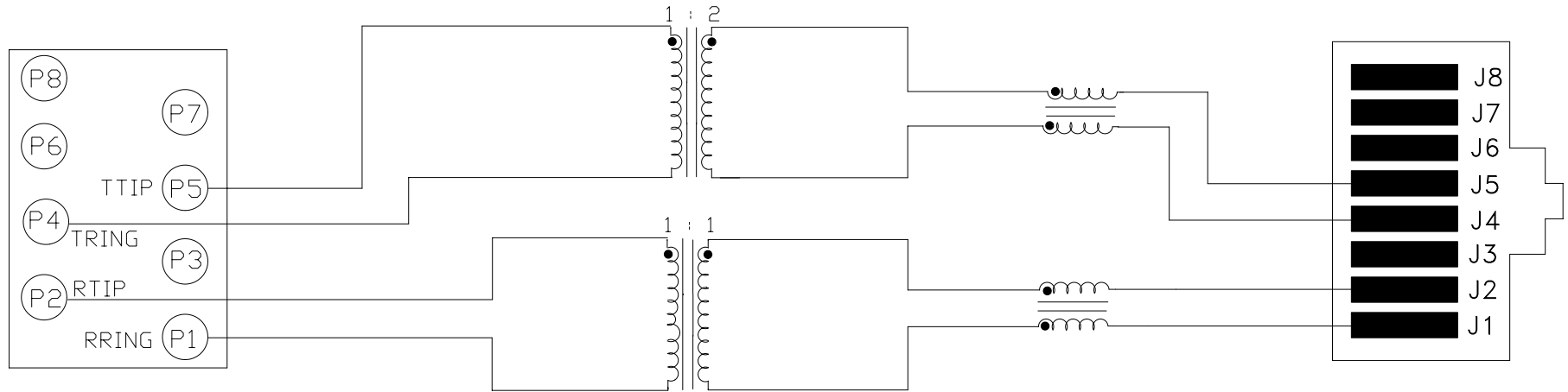

ELECTRICAL SPECIFICATIONS:

- | | |
|--|------------------------------|
| 1.0 TURNS RATIO: (P2-P1) : (J2-J1) | : 1 : 1 ± 3% |
| (P5-P4) : (J5-J4) | : 1 : 2 ± 3% |
| 2.0 INDUCTANCE: (P2-P1) ; (P5-P4) | : 1.2mH MIN. @ 0.1V, 100KHz |
| 3.0 LEAKAGE INDUCTANCE: P2-P1 (WITH J2 AND J1 SHORT) | : 0.5uH MAX. @ 1MHz |
| P5-P4 (WITH J5 AND J4 SHORT) | : 0.5uH MAX. @ 1MHz |
| 4.0 INTERWINDING CAPACITANCE: (P2,P1) TO (J2,J1) | : 35pf MAX @ 1MHz |
| (P5,P4) TO (J5,J4) | : 35pf MAX. @ 1MHz |
| 6.0 COMMON MODE ATTENUATION: | : -20dB TYP @ 5MHz TO 100MHz |
| 7.0 HIPOT: (P5-P4) TO (J5-J4) | : 1500VAC |
| (P2-P1) TO (J2-J1) | : 1500VAC |
| 8.0 RETURN LOSS: (J1-J2 & J4-J5) 100 OHM REF. | |
| 51KHz TO 102KHz | : 12dB MIN |
| 102KHz TO 2.048MHz | : 18dB MIN |
| 2.048MHz TO 3.072MHz | : 14dB MIN |

NOTES

1.0 PINS WITHOUT ELECTRICAL CONNECTION ARE OMITTED.

NOTE ; 25 OHMS CONNECTED TO PINS P1-P2 & P5-P4.

- | | |
|--------------------------------------|----------------|
| 9.0 DC RESISTANCE: (P5-P4) ; (P2-P1) | : .8 ohms Max. |
|--------------------------------------|----------------|

InNet Technologies inc.
<http://www.innet-tech.com>
 Stewart Connector Systems
<http://www.stewartconnector.com>

SHEET
1 OF 3

DRAWING NO.

SI-10217

REV. X

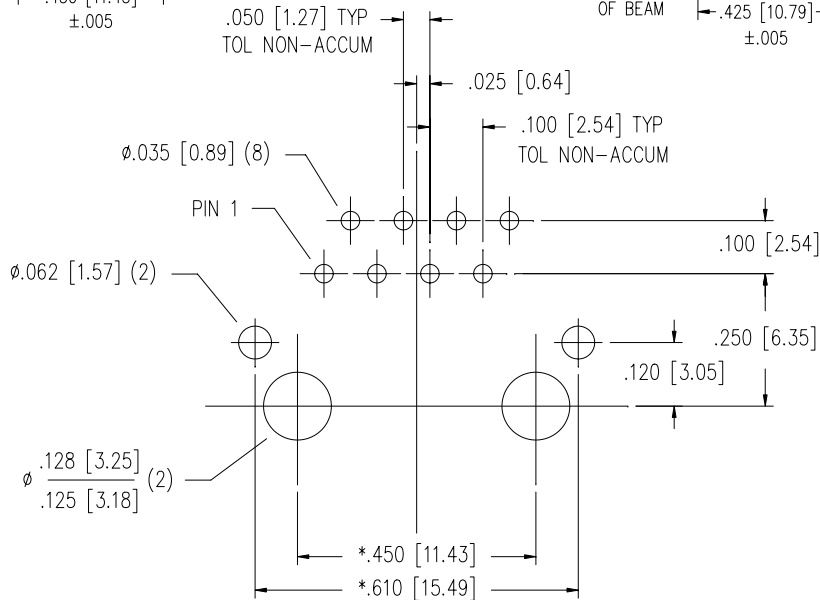
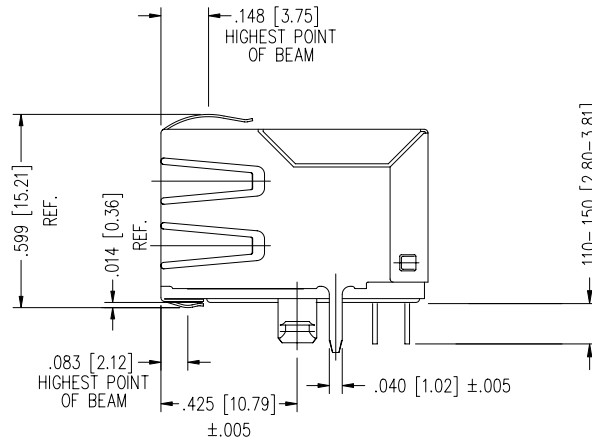
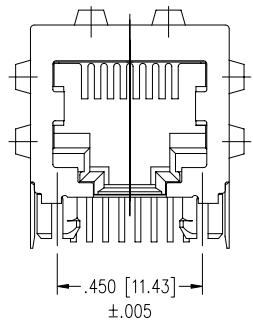
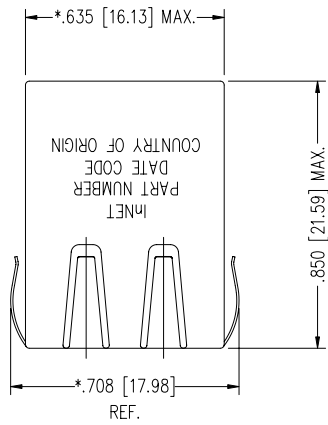

P.C.B. RECOMMENDED HOLE LAYOUT
SEEN FROM COMPONENT SIDE
TOLERANCE $\pm .003 [0.08]$ UNLESS OTHERWISE SPECIFIED

NOTES:

- TOLERANCES COMPLY WITH F.C.C. DIMENSION REQUIREMENTS
- DIMENSIONS SHOWN WITH "*" TO BE CENTRAL ABOUT CENTER LINE
- DIMENSIONS SHOWN ARE SUBJECT TO CHANGE WITHOUT NOTICE.
- PIN NOT ELECTRICALLY CONNECTED MAYBE OMITTED. SEE ELECTRICAL DRAWING FOR OMITTED PINS.
- STANDARD 50 MICRO-INCH SELECTIVE GOLD PLATING

InNet Technologies inc.
<http://www.innet-tech.com>
Stewart Connector Systems
<http://www.stewartconnector.com>

SHEET
2 OF 3

DRAWING NO. SI-10217 REV. 06

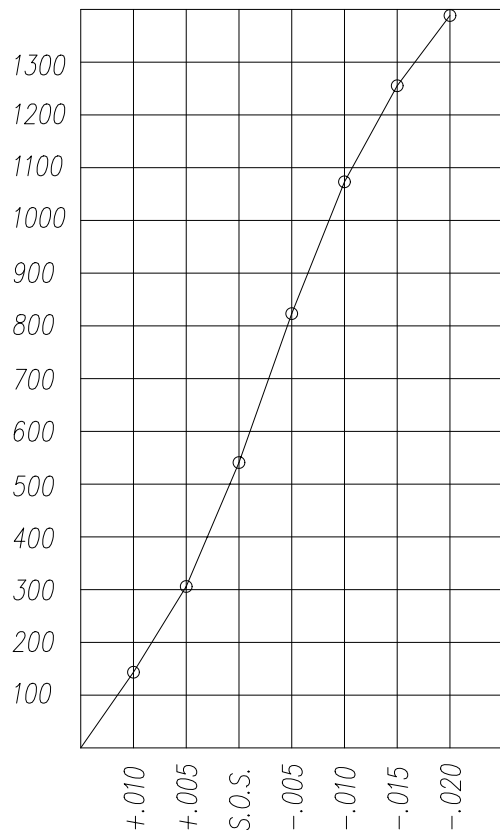

PANEL GROUNDING BEAM DEFLECTION
S.O.S. = SUGGESTED OPENING SIZE

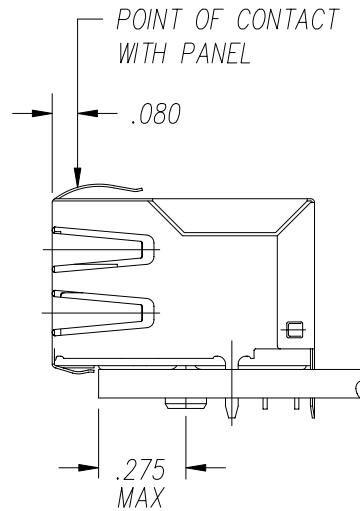

THE SUGGESTED PANEL OPENING IS INTENDED TO GIVE THE USER THE ABILITY TO HAVE REASONABLE JACK / PANEL CLEARANCES YET MAINTAIN RELIABLE GROUNDING CAPABILITY. THESE VARIABLES CAN BE ADJUSTED IN EITHER DIRECTION BUT MAY CARRY SOME CONSEQUENCES IN THE FORM OF LOWER MATING FORCES OR TIGHTER ASSEMBLY TOLERANCES. FORCE VALUES ON THE GRAPH ARE GENERAL AVERAGES TAKEN AT THE POINT OF CONTACT SHOWN ABOVE. THE SUGGESTED PANEL OPENING INCLUDES APPROXIMATELY .020 CLEARANCE ON THE SIDES AND TOP AND .013 ON THE BOTTOM, AT PANEL OPENING.

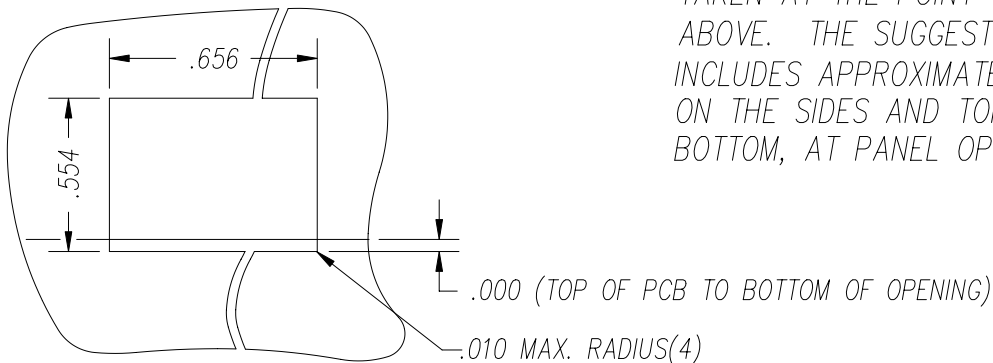

SUGGESTED PANEL OPENING

InNet Technologies inc.
<http://www.innet-tech.com>
 Stewart Connector Systems
<http://www.stewartconnector.com>

SHEET
3 OF 3

DRAWING NO. SI-10217 REV. 06