

DESCRIPTION

The LX5241/42 is a multimode SCSI terminator that conforms to the SCSI Parallel Interconnect-2 (SPI-2) specification developed by the T10 standards committee for low voltage differential (LVD) termination, while providing backwards compatibility to the SCSI, SCSI-2, and SPI single-ended specifications. Multimode compatibility permits the use of legacy devices on the bus without hardware alterations. Automatic mode selection is achieved through voltage detection on the diffsense line.

The LX5241/42 utilizes Linfinity's UltraMAX technology which delivers the ultimate in SCSI bus performance while saving component cost and board area. Elimination of the external capacitors also mitigates the need for a lengthy capacitor selection process. The individual high bandwidth drivers also maximize channel separation and reduce channel to channel noise and cross talk. The high bandwidth architecture insures ULTRA2 performance while providing a clear migration path to ULTRA3 and beyond.

When the LX5241/42 is enabled, the differential sense (DIFFSENSE) pin supplies a voltage between 1.2V and 1.4V. In application, this pin

is tied to the DIFFSENSE input of the corresponding LVD transceivers. This action enables the LVD transceiver function. DIFFSENSE is capable of supplying a maximum of 15mA. Tying the DIFFSENSE pin high places the LX5241/42 in a HI Z state indicating the presence of an HVD device. Tying the pin low places the part in a single-ended mode while also signaling the multimode transceiver to operate in a single-ended mode.

Recognizing the needs of portable and configurable peripherals, the LX5241/42 have a TTL compatible sleep/disable mode. During this sleep/disable mode, power dissipation is reduced to a meager 10µA while also placing all outputs in a HI Z state. Also during sleep/disable mode, the DIFFSENSE function is disabled and is placed in a HI Z state.

Another key feature of the LX5241/42 is the master / slave function. Driving this pin high or floating the pin enables the 1.3V DIFFSENSE reference. Driving the pin low disables the on board DIFFSENSE reference and enables use of an external master reference device.

KEY FEATURES

- AUTO-SELECTABLE LVD OR SINGLE-ENDED TERMINATION
- 3.0pF MAXIMUM DISABLED OUTPUT CAPACITANCE
- FAST RESPONSE, NO EXTERNAL CAPACITORS REQUIRED
- COMPATIBLE WITH ACTIVE NEGATION DRIVERS
- 5µA SUPPLY CURRENT IN DISCONNECT MODE
- LOGIC COMMAND DISCONNECTS ALL TERMINATION LINES
- DIFFSENSE LINE DRIVER
- GROUND DRIVER INTEGRATED FOR SINGLE-ENDED OPERATION
- CURRENT LIMIT AND THERMAL PROTECTION
- HOT-SWAP COMPATIBLE (SINGLE-ENDED)
- COMPATIBLE WITH SCSI 1, 2, 3, FAST-20, AND THE PENDING SPI-2 LVD
- SEE LX5245/5246 FOR LVD TERMINATION ONLY

IMPORTANT: For the most current data, consult Linfinity's web site: <http://www.linfinity.com>.

PRODUCT HIGHLIGHT

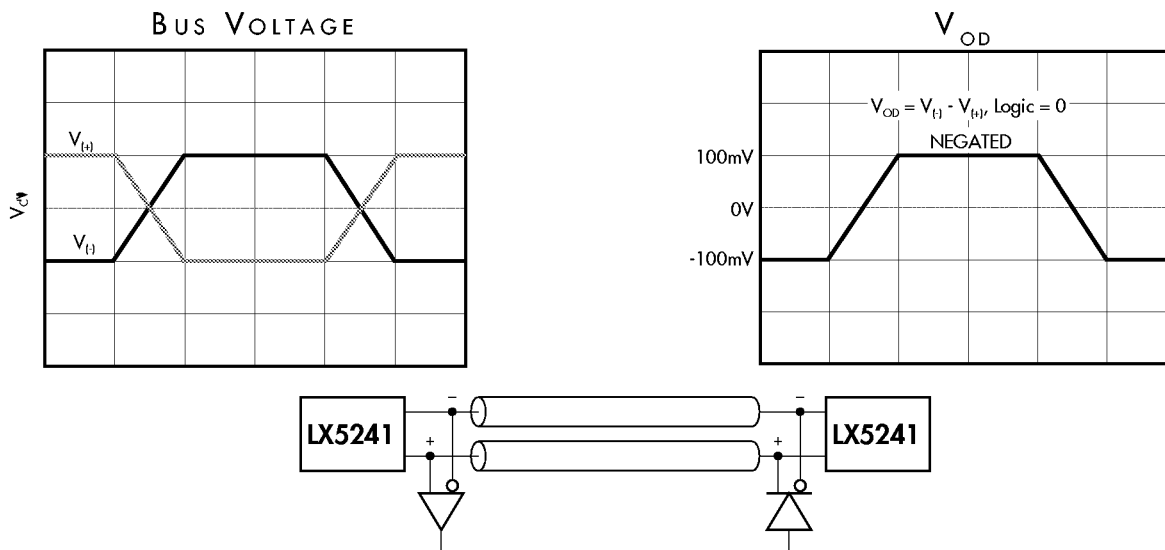

PACKAGE ORDER INFORMATION

T_A (°C)	DB Plastic SSOP 36-pin	PW Plastic TSSOP 24-pin	TF Plastic TQFP 48-pin
0 to 70	LX5241CDB LX5242CDB	LX5241CPW LX5242CPW	LX5241CTF LX5242CTF

Note: All surface-mount packages are available in Tape & Reel.
Append the letter "T" to part number. (i.e. LX5241/42CDBT)

MULTIMODE SCSI TERMINATOR PRELIMINARY DATA SHEET

ABSOLUTE MAXIMUM RATINGS (Note 1)

TermPwr Voltage	+7V
Operating Junction Temperature	
Plastic (DB, PW, TF Packages)	150°C
Storage Temperature Range	-65°C to 150°C
Lead Temperature (Soldering, 10 seconds)	300°C

Note 1. Exceeding these ratings could cause damage to the device. All voltages are with respect to Ground. Currents are positive into, negative out of the specified terminal.

THERMAL DATA

DB PACKAGE:

THERMAL RESISTANCE-JUNCTION TO AMBIENT, θ_{JA} **50°C/W**

PW PACKAGE:

THERMAL RESISTANCE-JUNCTION TO AMBIENT, θ_{JA} **100°C/W**

TF PACKAGE:

THERMAL RESISTANCE-JUNCTION TO AMBIENT, θ_{JA} **65°C/W**

Junction Temperature Calculation: $T_J = T_A + (P_D \times \theta_{JA})$.

The θ_{JA} numbers are guidelines for the thermal performance of the device/pc-board system. All of the above assume no ambient airflow.

MASTER / SLAVE FUNCTION TABLE

MASTER / SLAVE	DIFFSENSE Status	Output Current
L*	HI Z	0mA
H	1.3V	15mA Source
Open (Pull-up)	1.3V	15mA Source

* When in Low state, terminator will detect state of DIFFSENSE line.

DIFFSENSE / POWER UP / POWER DOWN FUNCTION TABLE

LX5241 DISCONNECT	LX5242 DISCONNECT	DIFF SENSE	Outputs		Quiescent Current
			Status	Type	
L	H	L < 0.5V	Enable	S.E.	7mA
L	H	0.7 - 1.9V	Enable	LVD	21mA
L	H	H > 2.4V	Disable	HI Z	1mA
H Open	L Open	X	Disable	HI Z	10µA

PACKAGE PIN OUTS

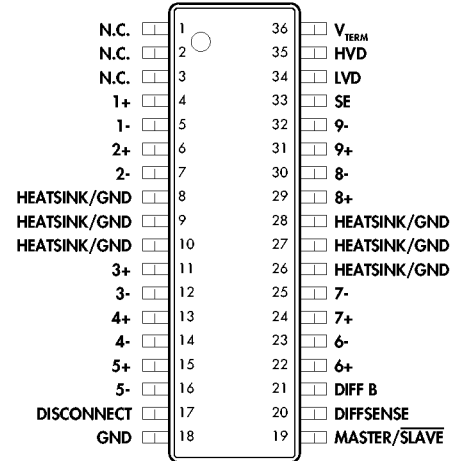

DB PACKAGE (Top View)

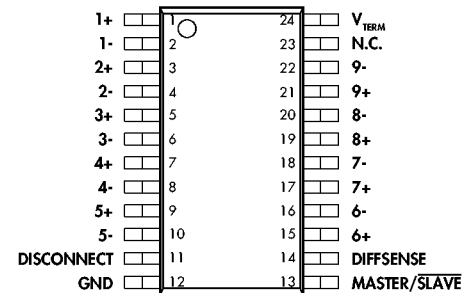

PW PACKAGE (Top View)

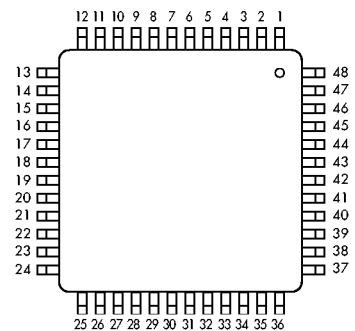

TF PACKAGE (Top View)

1. MSTR/SLV	13. 8+	25. N.C.	37. N.C.
2. DIFFSENSE	14. 8-	26. N.C.	38. 3+
3. DIFFB	15. 9+	27. N.C.	39. 3-
4. N.C.	16. 9-	28. N.C.	40. 4+
5. HS/GND	17. HS/GND	29. HS/GND	41. 4-
6. HS/GND	18. HS/GND	30. HS/GND	42. HS/GND
7. HS/GND	19. HS/GND	31. HS/GND	43. HS/GND
8. HS/GND	20. SE	32. HS/GND	44. HS/GND
9. 6+	21. LVD	33. 1+	45. 5+
10. 6-	22. HVD	34. 1-	46. 5-
11. 7+	23. TERMPWR	35. 2+	47. DISCNCT
12. 7-	24. N.C.	36. 2-	48. GND

MULTIMODE SCSI TERMINATOR

PRELIMINARY DATA SHEET

RECOMMENDED OPERATING CONDITIONS (Note 2)

Parameter	Symbol	Recommended Operating Conditions			Units
		Min.	Typ.	Max.	
Tempwr Voltage LVD SE	V_{TERM}	3.0		5.25	V
		3.5		5.25	V
Signal Line Voltage		0		5.0	V
Disconnect Input Voltage		0		V_{TERM}	V
Operating Virtual Junction Temperature Range LX5241 / 5242C		0		70	°C

Note 2. Range over which the device is functional.

ELECTRICAL CHARACTERISTICS

(Unless otherwise specified, these specifications apply over the operating ambient temperature range of $0^{\circ}\text{C} \leq T_A \leq 70^{\circ}\text{C}$, TermPwr = 4.75V. For the LX5241 DISCONNECT = L, for the LX5242 DISCONNECT = H. Low duty cycle pulse testing techniques are used which maintains junction and case temperatures equal to the ambient temperature.)

Parameter	Symbol	Test Conditions	LX5241 / 5242			Units
			Min.	Typ.	Max.	
LVD Terminator Section						
TermPwr Supply Current		All term lines = Open		21	25	mA
		LX5241: DISCONNECT > 2.0V, LX5242: DISCONNECT < 0.8V		5	10	μA
Common Mode Voltage			1.125	1.25	1.375	V
Offset Voltage		Open circuit between - and + (see Note 3)	100	112	125	mV
Differential Terminator Impedance		-1V to 1V	100	105	110	Ω
Common Mode Impedance		0V to 2.5V	100	200	300	Ω
Output Capacitance		LX5241: DISCONNECT > 2.0V, LX5242: DISCONNECT < 0.8V		2.5		pF
Output Leakage		LX5241: DISCONNECT > 2.0V, LX5242: DISCONNECT < 0.8V, $V_{LINE} = 0$ to 4V, $T_A = 25^{\circ}\text{C}$			2	μA
		LX5241: DISCONNECT > 2.0V, LX5242: DISCONNECT < 0.8V, $V_{TERM} = 0\text{V}$, $V_{LINE} = 2.7\text{V}$		1		μA
Mode Change Delay		DIFFSENSE = 1.4V to 0V		115		ms
DIFFSENSE Section						
DIFFSENSE Output Voltage			1.2	1.3	1.4	V
DIFFSENSE Output Source Current		$V_{DIFF} = 0\text{V}$	5.0		15.0	mA
DIFFSENSE Sink Current		$V_{DIFF} = 2.75\text{V}$			200	μA
DIFFSENSE Output Leakage		LX5241: DISCONNECT > 2.0V, LX5242: DISCONNECT < 0.8V, $T_A = 25^{\circ}\text{C}$			10	μA
Single-Ended Termination Section						
Tempwr Supply Current		All term lines = Open, Master/Slave = 0V		7	10	mA
		All term lines = 0.2V, Master/Slave = 0V		214	226	mA
		LX5241: DISCONNECT > 2.0V, LX5242: DISCONNECT < 0.8V		5.0	10.0	μA
Terminator Output High Volt			2.6	2.85		V
Output Current		$V_{OUT} = 0.2\text{V}$	21	23	24	mA
Sink Current		$V_{OUT} = 4\text{V}$, All lines	45	65		mA
Output Capacitance		LX5241: DISCONNECT > 2.0V, LX5242: DISCONNECT < 0.8V		2.5		pF
Leakage Current		LX5241: DISCONNECT > 2.0V, LX5242: DISCONNECT < 0.8V, $V_{OUT} = 0$ to 4V, $T_A = 25^{\circ}\text{C}$			2	μA
		LX5241: DISCONNECT > 2.0V, LX5242: DISCONNECT < 0.8V, $V_{TERM} = \text{Open}$, $V_{LINE} = 2.7\text{V}$, $T_A = 25^{\circ}\text{C}$		1		μA

Note 3. Open circuit failsafe voltage.

MULTIMODE SCSI TERMINATOR PRELIMINARY DATA SHEET

ELECTRICAL CHARACTERISTICS

Parameter	Symbol	Test Conditions	LX5241 / 5242			Units
			Min.	Typ.	Max.	
Single-Ended Termination Section (continued)						
Ground Driver Impedance		I = 1mA			100	Ω
Thermal Shutdown				150		$^{\circ}\text{C}$
DISCONNECT Section						
DISCONNECT Thresholds			0.8		2.0	V
Input Current	LX5241	DISCONNECT = 0V			10	μA
	LX5242	DISCONNECT = 0V		100		nA
	LX5241	DISCONNECT = 2.4V		100		nA
	LX5242	DISCONNECT = 2.4V			10	μA
MASTER / SLAVE Section						
MASTER / SLAVE Thresholds			0.8		2.0	V
Input Current		MASTER / SLAVE = 0V			10	μA
		MASTER / SLAVE = 2.4V		100		nA

BLOCK DIAGRAM

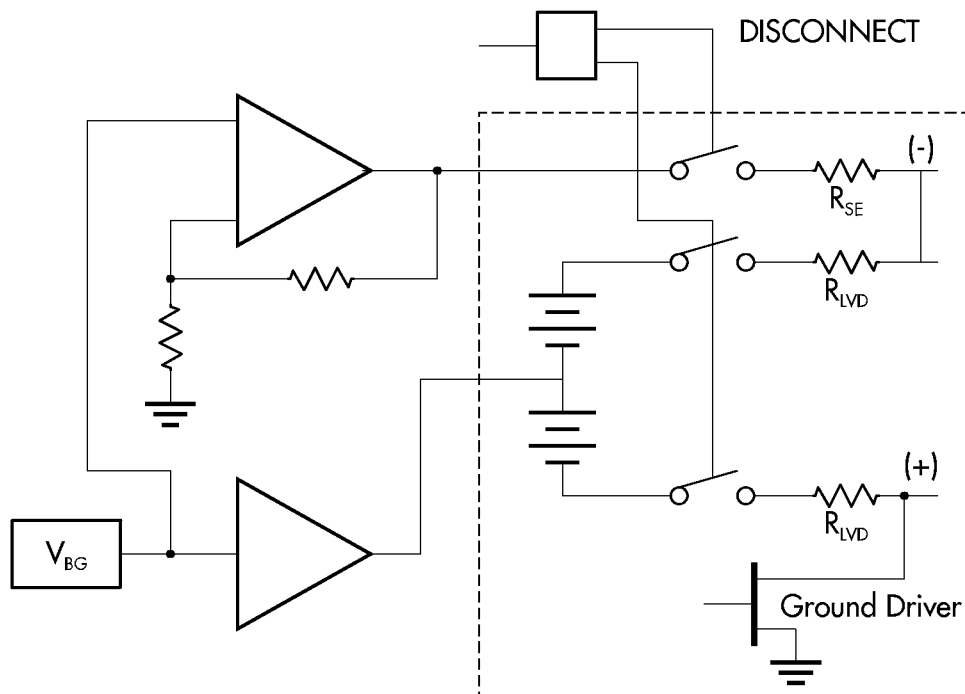
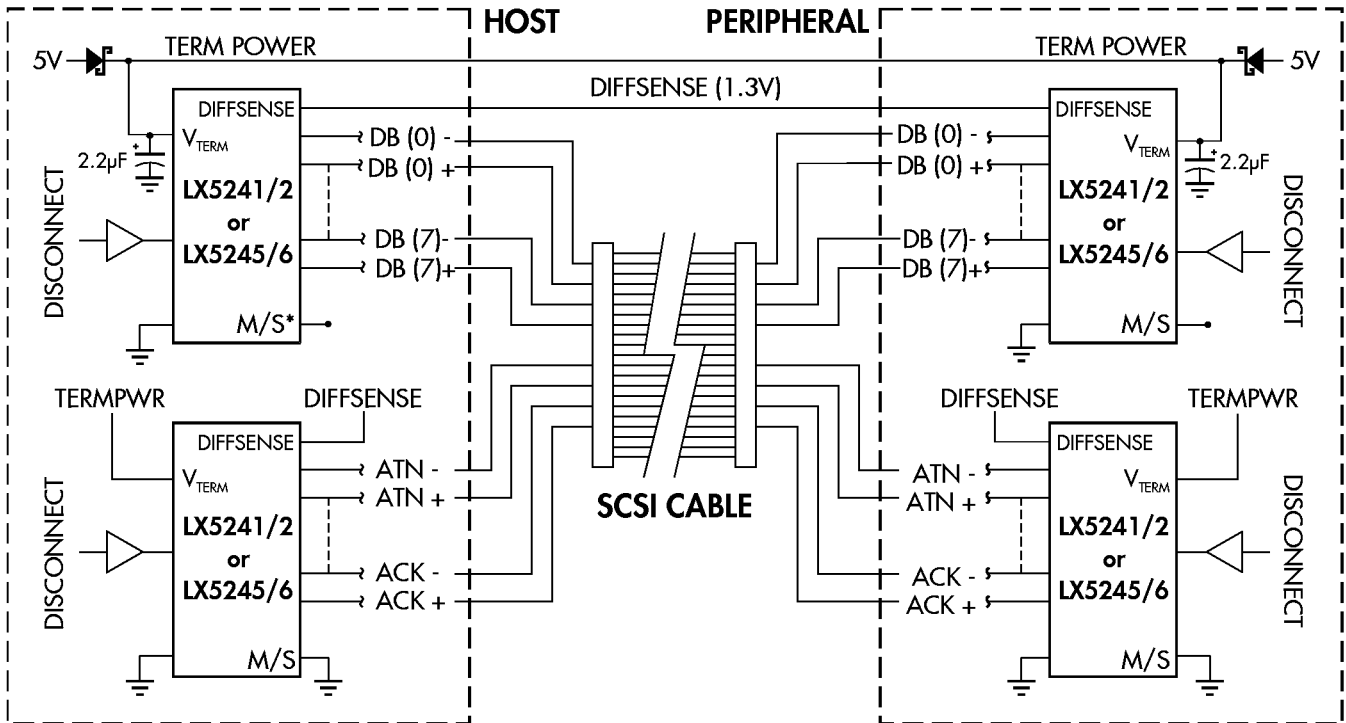

FIGURE 1 — LX5241/5242 Block Diagram

MULTIMODE SCSI TERMINATOR
PRELIMINARY DATA SHEET

APPLICATION SCHEMATIC



Note: Single-ended the + signals become ground, DIFFSENSE < 0.5V
* M/S = MASTER/SLAVE

FIGURE 2 — LX5241/5242 Application Schematic

UltraMAX is a trademark of LinFinity Microelectronics Inc.

PRELIMINARY DATA - Information contained in this document is pre-production data, and is proprietary to LinFinity. It may not be modified in any way without the express written consent of LinFinity. Product referred to herein is offered in sample form only, and LinFinity reserves the right to change or discontinue this proposed product at any time.

Package Information

MECHANICAL DIMENSIONS

TF 48-Pin Thin Quad Flat Pack (TQFP)

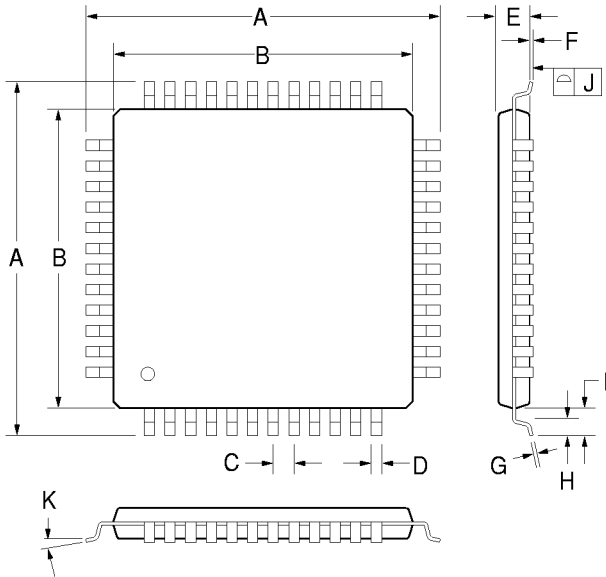

DIM	Millimeters		Inches	
	MIN	MAX	MIN	MAX
A	8.90	9.10	0.350	0.358
B	6.90	7.10	0.272	0.280
C	0.50 TYP		0.020 TYP	
D	0.17	0.27	0.007	0.012
E	1.35	1.45	0.053	0.057
F	0.05	0.15	0.002	0.006
G	0.090	0.200	0.004	0.008
H	0.45	0.75	0.018	0.030
I	1.00 TYP		0.039 TYP	
J		0.08		0.003
K	0	7	0	7

Note:

- Dimensions do not include mold flash or protrusions; these shall not exceed 0.254mm (.010") on any side. Lead dimension shall not include solder coverage.

PW 20-Pin Thin Small Shrink Outline (TSSOP)

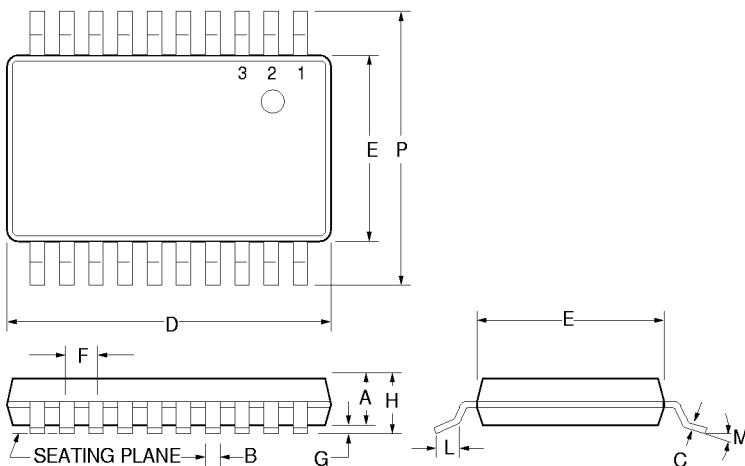

DIM	Millimeters		Inches	
	MIN	MAX	MIN	MAX
A	0.80	1.05	0.032	0.041
B	0.19	0.30	0.007	0.012
C	0.09	0.180	0.0035	0.0071
D	6.40	6.60	0.252	0.260
E	4.30	4.48	0.169	0.176
F	0.65 BSC		0.025 BSC	
G	0.05	0.15	0.002	0.005
H		1.10		0.0433
L	0.50	0.70	0.020	0.028
M	0	8	0	8
P	6.25	6.50	0.246	0.256
*LC		0.10		0.004

* Lead Coplanarity

Note:

- Dimensions do not include mold flash or protrusions; these shall not exceed 0.15mm (.006") on any side. Lead dimension shall not include solder coverage.

Package Information

MECHANICAL DIMENSIONS

PW 24-Pin Thin Small Shrink Outline (TSSOP)

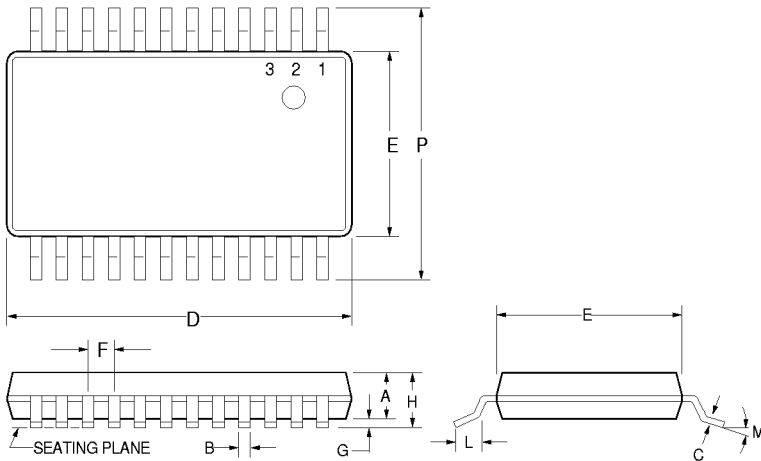

DIM	Millimeters		Inches	
	MIN	MAX	MIN	MAX
A	0.80	1.05	0.032	0.041
B	0.19	0.30	0.007	0.012
C	0.09	0.180	0.0035	0.0071
D	7.70	7.90	0.303	0.311
E	4.30	4.48	0.169	0.176
F	0.65 BSC		0.025 BSC	
G	0.05	0.15	0.002	0.005
H		1.10		0.0433
L	0.50	0.70	0.020	0.028
M	0	8	0	8
P	6.25	6.50	0.246	0.256
*LC		0.10		0.004

* Lead Coplanarity

Note:

1. Dimensions do not include mold flash or protrusions; these shall not exceed 0.15mm (.006") on any side. Lead dimension shall not include solder coverage.

PW 56-Pin Thin Small Shrink Outline (TSSOP)

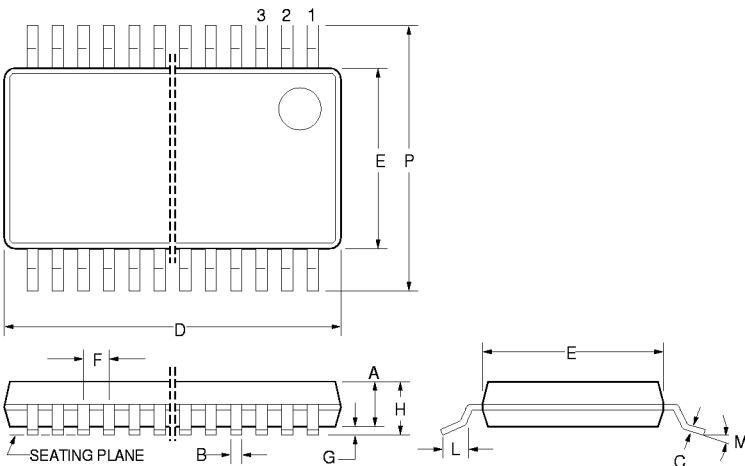

DIM	Millimeters		Inches	
	MIN	MAX	MIN	MAX
A	0.80	1.05	0.032	0.041
B	0.17	0.27	0.007	0.011
C	0.09	0.20	0.004	0.008
D	13.90	14.10	0.547	0.555
E	6.0	6.2	0.236	0.244
F	0.50 BSC		0.02 BSC	
G	0.05	0.15	0.002	0.005
H		1.20		0.047
L	0.45	0.75	0.018	0.030
M	0	8	0	8
P	8.1 BSC		0.32 BSC	
*LC		0.10		0.004

* Lead Coplanarity

Note:

1. Dimensions do not include mold flash or protrusions; these shall not exceed 0.15mm (.006") on any side. Lead dimension shall not include solder coverage.

Package Information

MECHANICAL DIMENSIONS

DB 28-Pin Shrink Small Outline Package (SSOP)

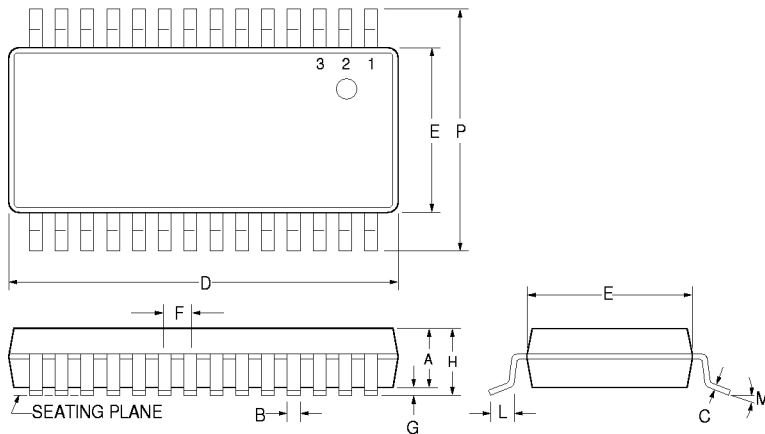

DIM	Millimeters		Inches	
	MIN	MAX	MIN	MAX
A	1.65	1.85	0.065	0.073
B	0.25	0.38	0.009	0.015
C	0.13	0.22	0.005	0.008
D	9.90	10.50	0.390	0.413
E	5.00	5.60	0.197	0.221
F	0.65 BSC		0.025 BSC	
G	0.05	0.21	0.002	0.008
H	1.73	2.00	0.068	0.078
L	0.65	0.95	0.025	0.037
M	0	8	0	8
P	7.65	7.90	0.301	0.311
*LC		0.10		0.004

* Lead Coplanarity

Note:

- Dimensions do not include mold flash or protrusions; these shall not exceed 0.15mm (.006") on any side. Lead dimension shall not include solder coverage.

DB 36-Pin Shrink Small Outline Package (SSOP)

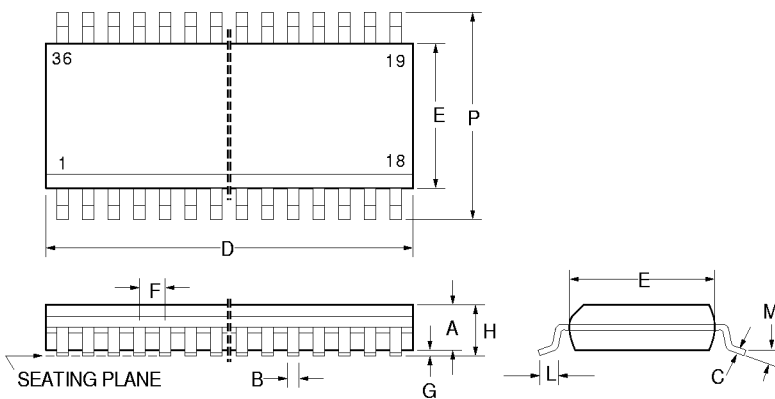

DIM	Millimeters		Inches	
	MIN	MAX	MIN	MAX
A	2.14	2.54	0.084	0.100
B	0.29	0.51	0.011	0.020
C	0.23	0.32	0.0091	0.0125
D	15.20	15.40	0.598	0.606
E	7.40	7.60	0.291	0.299
F	0.80 BSC		0.031 BSC	
G	0.10	0.30	0.004	0.012
H	2.44	2.64	0.096	0.104
L	0.51	1.01	0.020	0.040
M	0	8	0	8
P	10.11	10.51	0.398	0.414
*LC		0.10		0.004

* Lead Coplanarity

Note:

- Dimensions do not include mold flash or protrusions; these shall not exceed 0.15mm (.006") on any side. Lead dimension shall not include solder coverage.