

LXT970

Dual-Speed Fast Ethernet Transceiver

General Description

The LXT970 is an IEEE 802.3 compliant 10/100 Mbps Fast Ethernet PHY Transceiver that directly supports both 100BASE-TX and 10BASE-T applications. It provides a Media Independent Interface (MII) for easy attachment to 10/100 Media Access Controllers (MAC)s. The LXT970 also provides a pseudo-ECL interface for use with 100BASE-FX fiber networks.

The LXT970 supports full-duplex operation at 10 and 100 Mbps. Its operating condition can be set using auto-negotiation, parallel detection or manual control. The encoder can be bypassed for symbol mode applications.

The LXT970 is fabricated with an advanced CMOS process and requires only a single 5V power supply. The MII may be operated independently with either a 5V or a 3.3V supply.

Applications

- Combination 10BASE-T/100BASE-TX Network Interface Cards (NICs)
- 10/100 Switches, 10/100 Repeaters
- 100BASE-FX Network Interface Cards (NICs)

Features

- IEEE 802.3 Compliant:
 - 10BASE-T and 100BASE-TX using a single RJ45 connection.
 - Supports auto-negotiation and parallel detection for legacy systems.
 - MII interface with extended register capability.
- Robust Baseline wander correction performance.
- 100BASE-FX fiber optic capable.
- Standard CSMA/CD or full-duplex operation.
- Configurable through MII serial port or via external control pins.
- Configurable for DTE or switch applications.
- Provision for interface to 3.3V MII bus.
- Integrated transmit and receive filtering.
- Integrated LED drivers.
- Integrated supply monitor and line disconnect during low supply fault.
- Available in:
 - 64-pin LQFP package (LXT970LC)
 - 64-pin PQFP (LXT970QC)
- Commercial temperature range (0 to +70°C ambient).

LXT970 Block Diagram

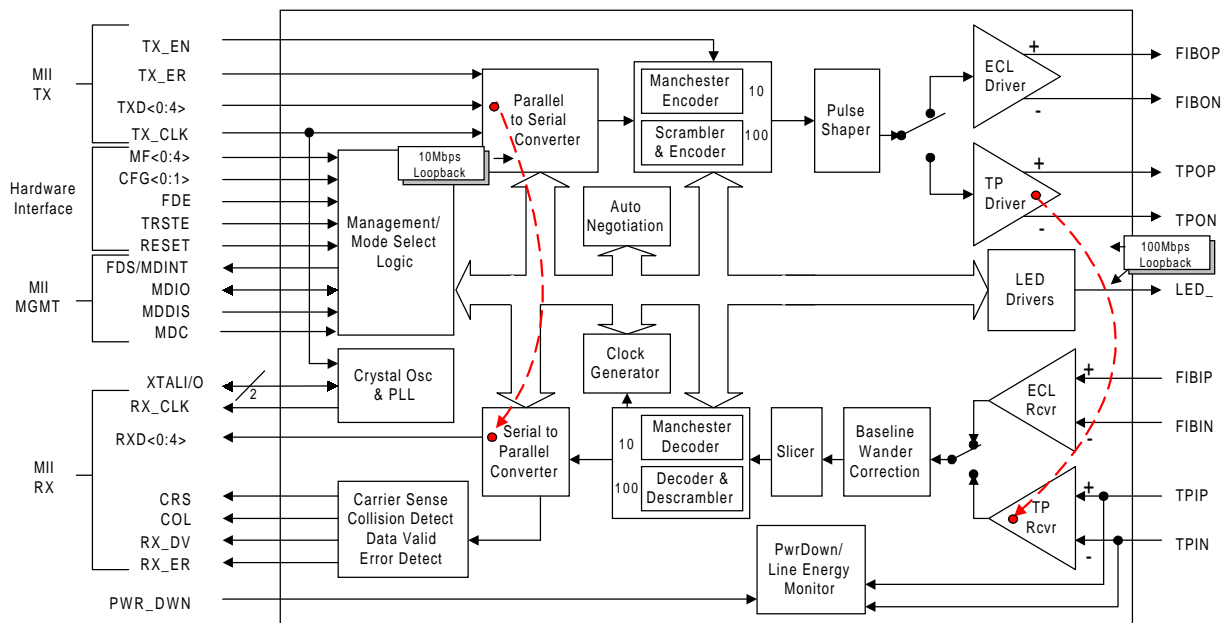

TABLE OF CONTENTS

PIN ASSIGNMENTS AND SIGNAL DESCRIPTIONS	4
FUNCTIONAL DESCRIPTION	13
Interfaces (Network Media/Protocol Support)	14
Twisted-Pair Interface.....	14
Fiber Interface	14
MII Interface	15
MII Data Interface	15
Repeater Mode	17
MII Management Interface (MDIO)	18
Hardware Control Interface	19
Configuring the LXT970 via Hardware Control	19
Operating Configurations/Auto-Negotiation Enabled	19
Operating Configurations/Auto-Negotiation Disabled	20
Operating Requirements	21
Power Supply Requirements	21
Reference Clock Requirements	21
Initialization	22
Control Mode Selection	22
Link Configuration	22
Auto-Negotiation/Parallel Detection	23
Monitoring Operational Status.....	24
100BASE-X Operation	25
4B/5B Coding Table.....	26
10BASE-T Operation	27
Protocol Sublayer Operation	28
PCS Layer	28
Errors and Collision	29
PMA Layer.....	30
Twisted-Pair PMD Layer.....	31
Baseline Wander Correction	31
Fiber PMD Layer	31
Additional Operating Features	32
APPLICATION INFORMATION	33
Magnetics Information.....	33
Crystal Information.....	34
Design Recommendations / General Design Practices	35
Interfaces for Twisted-Pair/Fiber	36
Typical Interface Circuitry	38

TEST SPECIFICATIONS	39
Absolute Maximum Ratings	37
Recommended Operating Conditions	37
Digital I/O Characteristics	38
Required Clock Characteristics	39
10BASE-T Link Integrity	43
100BASE-TX Transceiver Characteristics	42
100BASE-FX Transceiver Characteristics	42
10BASE-T Transceiver Characteristics	43
100BASE-TX Receive Timing 4B Mode	44
100BASE-TX Transmit Timing 4B Mode	45
100BASE-TX Receive Timing 5B Mode	46
100BASE-TX Transmit Timing 5B Mode	47
100BASE-FX Receive Timing 4B Mode	48
100BASE-FX Transmit Timing 4B Mode	49
10BASE-T Receive Timing	50
10BASE-T Transmit Timing	51
10BASE-T SQE (Heartbeat) Timing	52
Auto Negotiation and Fast Link Pulse Timing	53
MDIO and MII Timing	54
Power-Down Recovery Timing	55
REGISTER DEFINITIONS	56
Control Register (Address 0)	57
Status Register (Address 1)	58
PHY Identification Register (Address 2) / (Address 3)	59
Auto Negotiation Advertisement Register (Address 4)	60
Auto Negotiation Link Partner Ability Register (Address 5)	61
Auto Negotiation Expansion (Address 6)	62
Mirror Register (Address 16)	62
Interrupt Enable Register (Address 17)	63
Interrupt Status Register (Address 18)	63
Configuration Register (Address 19)	64
Chip Status Register (Address 20)	66
MECHANICAL SPECIFICATIONS	67
REVISION HISTORY	69

PIN ASSIGNMENTS AND SIGNAL DESCRIPTIONS

Figure 1: LXT970 Pin Assignments

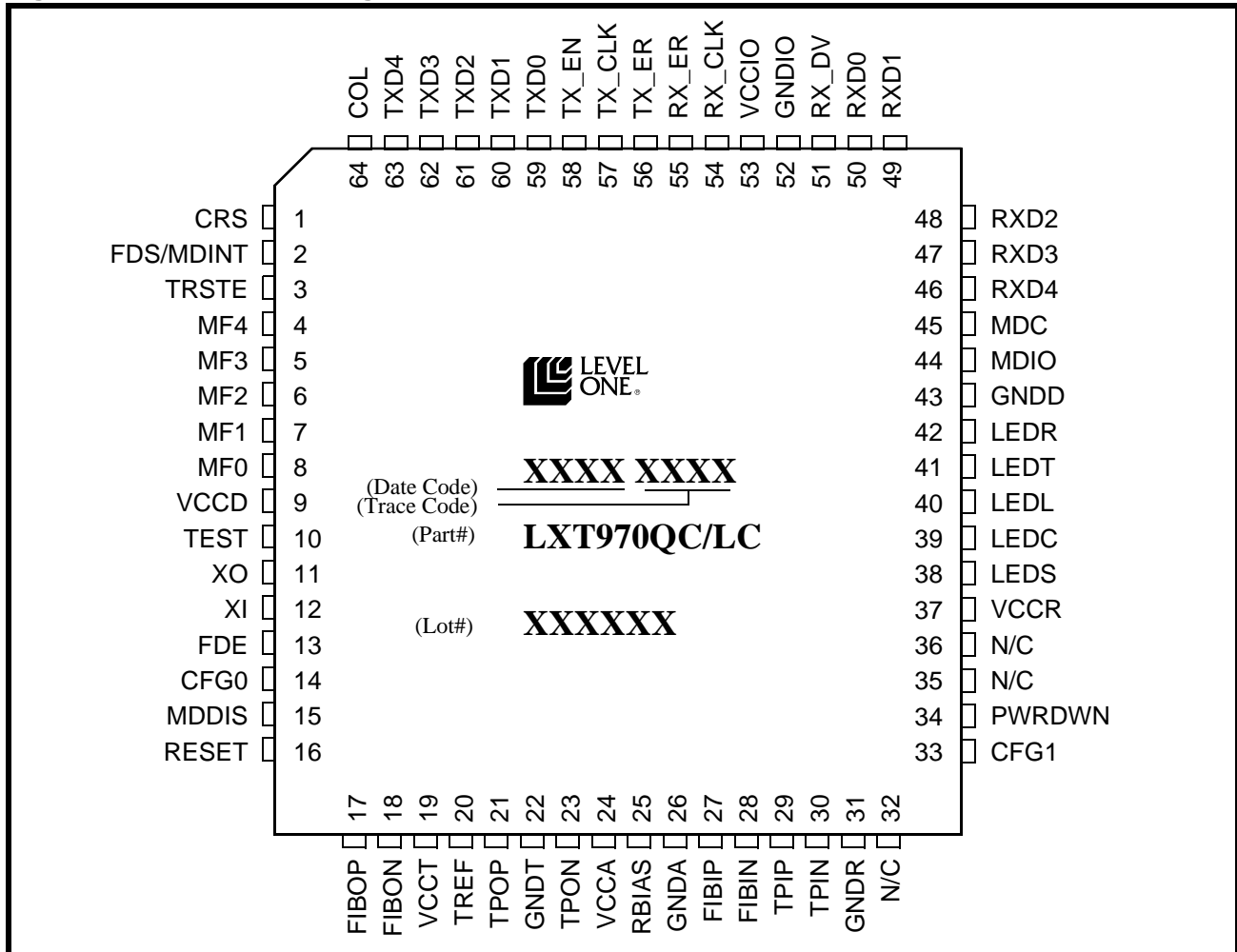

Table 1: LXT970 Power Supply Signal Descriptions

Pin# ¹	Pin Name	I/O	Signal Description
19 22	VCCT GNDT	-	Transmitter Supply (+5V) and Ground. (Analog plane)
37 31	VCCR GNDR	-	Receiver Supply (+5V) and Ground. (Analog plane)
24 26	VCCA GNDA	-	Analog Supply (+5V) and Ground.
9 43	VCCD GNDD	-	Digital Supply (+5V) and Ground.
53 52	VCCIO GNDIO	-	MII Supply (+3.3V or +5V) and Ground. (Digital plane)

1. Pin numbers apply to both package types (PQFP and LQFP).

Table 2: LXT970 MII Signal Descriptions

Pin# ¹	Pin Name	I/O ^{2,3}	Signal Description ⁴
MII Data Interface Pins			
63 62 61 60 59	TXD4 TXD3 TXD2 TXD1 TXD0	I	Transmit Data. The MAC drives data to the LXT970 using these inputs. TXD4 is monitored only in Symbol (5B) Mode. These signals must be synchronized to the TX_CLK.
58	TX_EN	I	Transmit Enable. The MAC asserts this signal when it drives valid data on the TXD inputs. This signal must be synchronized to the TX_CLK.
57	TX_CLK	I/O	Transmit Clock. Normally the LXT970 drives TX_CLK; in Slave Clock Mode TX_CLK is an input. Refer to the Clock Requirements discussion in the Functional Description section. 25 MHz for 100 Mbps operation. 2.5 MHz for 10 Mbps operation.
56	TX_ER	I	Transmit Coding Error. The Media Access Controller (MAC) asserts this input when an error has occurred in the transmit data stream. When the LXT970 is operating at 100 Mbps, the LXT970 responds by sending invalid code symbols on the line.
46 47 48 49 50	RXD4 RXD3 RXD2 RXD1 RXD0	O	Receive Data. The LXT970 drives received data on these outputs, synchronous to RX_CLK. RXD4 is driven only in Symbol (5B) Mode.
51	RX_DV	O	Receive Data Valid. The LXT970 asserts this signal when it drives valid data on RXD. This output is synchronous to RX_CLK.
55	RX_ER	O	Receive Error. The LXT970 asserts this output when it receives invalid symbols from the network. This signal is synchronous to RX_CLK.
54	RX_CLK	O	Receive Clock. Refer to the Clock Requirements discussion in the Functional Description section. 25 MHz for 100 Mbps operation. 2.5 MHz for 10 Mbps operation.
64	COL	O	Collision Detected. The LXT970 asserts this output when a collision is detected. This output remains High for the duration of the collision. This signal is asynchronous and is inactive during full-duplex operation.
1	CRS	O	Carrier Sense. During half-duplex operation (bit 0.8 = 0), the LXT970 asserts this output when either transmit or receive medium is non-idle. During full-duplex operation (bit 0.8 = 1) or repeater operation (bit 19.13 = 1), CRS is asserted only when the receive medium is non-idle.
<ol style="list-style-type: none"> Pin numbers apply to both package types (PQFP and LQFP). I/O Column Coding: I = Input, O = Output, OD = Open Drain, A = Analog. The MII outputs of the LXT970 are high-strength drivers that can effectively source 50-60 mA. 55Ω series termination resistors are recommended on all output signals to avoid undershoot/overshoot, even on short traces. The LXT970 supports the 802.3 MDIO register set. Specific bits in the registers are referenced using an "X.Y" notation, where X is the register number (0-6 or 16-20) and Y is the bit number (0-15). 			

Table 2: LXT970 MII Signal Descriptions – continued

Pin# ¹	Pin Name	I/O ^{2,3}	Signal Description ⁴
3	TRSTE	I	<p>Tristate. In DTE Mode (19.13 = 0), when TRSTE input is High, the LXT970 isolates itself from the MII Data Interface, and controls the MDIO register bit 0.10 (Isolate bit). When MDDIS is High, TRSTE provides continuous control over bit 0.10. When MDDIS is Low, TRSTE sets initial (default) values only and reverts control back to the MDIO interface.</p> <p>In Repeater Mode (19.13 = 1), when TRSTE input is High, the LXT970 tri-states the receive outputs of the MII (RXD<4:0>, RX_DV, RX_ER, RX_CLK).</p>
MII Control Interface Pins			
15	MDDIS	I	<p>Management Disable. When MDDIS is High, the MDIO is restricted to Read Only and the MF<4:0>, CFG<1:0> and FDE pins provide continual control of their respective bits. When MDDIS is Low at power up or Reset, the MF<4:0>, CFG<1:0> and FDE pins control only the initial or “default” values of their respective register bits. After the power-up/reset cycle is complete, bit control reverts to the MDIO serial channel.</p>
45	MDC	I	<p>Management Data Clock. Clock for the MDIO serial data channel. Maximum frequency is 2.5 MHz.</p>
44	MDIO	I/O	<p>Management Data Input/Output. Bidirectional serial data channel for PHY/STA communication.</p>
2	FDS/MDINT	OD	<p>Full-Duplex Status. When bit 17.1 = 0 (default), this pin indicates full-duplex status. (High = full-duplex, Low = half-duplex)</p> <p>This pin can drive a high efficiency LED. (See Table 24 for detail specifications).</p> <p>Management Data Interrupt. When bit 17.1 = 1, an active Low output on this pin indicates status change.</p> <p>Interrupt is cleared by sequentially reading Register 1, then Register 18.</p>
<p>1. Pin numbers apply to both package types (PQFP and LQFP).</p> <p>2. I/O Column Coding: I = Input, O = Output, OD = Open Drain, A = Analog.</p> <p>3. The MII outputs of the LXT970 are high-strength drivers that can effectively source 50-60 mA. 55Ω series termination resistors are recommended on all output signals to avoid undershoot/overshoot, even on short traces.</p> <p>4. The LXT970 supports the 802.3 MDIO register set. Specific bits in the registers are referenced using an “X.Y” notation, where X is the register number (0-6 or 16-20) and Y is the bit number (0-15).</p>			

Table 3: LXT970 Fiber Interface Signal Descriptions

Pin# ¹	Pin Name	I/O ²	Signal Description
17 18	FIBOP FIBON	O	Fiber Output, Positive and Negative. Differential pseudo-ECL driver pair compatible with standard fiber transceiver for 100BASE-FX.
27 28	FIBIP FIBIN	I	Fiber Input, Positive and Negative. Differential pseudo-ECL receive pair compatible with standard fiber transceiver for 100BASE-FX.

1. Pin numbers apply to both package types (PQFP and LQFP).
2. I/O Column Coding: I = Input, O = Output, OD = Open Drain, A = Analog.

Table 4: LXT970 Twisted-Pair Interface Signal Descriptions

Pin# ¹	Pin Name	I/O ²	Signal Description
21 23	TPOP TPON	AO	Twisted-Pair Output, Positive and Negative. Differential driver pair produces 802.3-compliant pulses for either 100BASE-TX or 10BASE-T transmission.
20	TREF	AO	Transmit Reference. Tie to center tap of output transformer.
29 30	TPIP TPIN	AI	Twisted-Pair Input, Positive and Negative. Differential input pair for either 100BASE-TX or 10BASE-T reception.

1. Pin numbers apply to both package types (PQFP and LQFP).
2. I/O Column Coding: I = Input, O = Output, OD = Open Drain, A = Analog.

Table 5: LXT970 LED Indicator Signal Descriptions

Pin# ¹	Pin Name	I/O ²	Signal Description ³
38	LEDS	O	Speed LED. Active Low output indicates 100 Mbps operation is selected.
42	LEDR	O	Receive LED. Active Low output indicates that receiver is active.
41	LEDT	O	Transmit LED. Active Low output indicates transmitter is active.
40	LEDL	O	Link LED. Active Low output; During 100 Mbps operation, indicates scrambler lock and receipt of valid Idle codes. During 10 Mbps operation, indicates Link Valid status.
39	LEDC	O	Collision LED. In default mode, active Low output indicates collision. However, LEDC is programmable and may be set for other indications. For programming options, see Configuration Register 19 in Table 56.

1. Pin numbers apply to both package types (PQFP and LQFP).
2. I/O Column Coding: I = Input, O = Output, OD = Open Drain, A = Analog.
3. LEDs are read at power-up to determine scrambler seed values.

Table 6: LXT970 Miscellaneous Signal Descriptions

Pin# ¹	Pin Name	I/O ²	Signal Description
10	TEST	I	Test. Must be tied Low.
12 11	XI XO	I O	Crystal Input and Output. A 25 MHz crystal oscillator circuit can be connected across XI and XO. A clock can also be used at XI. Refer to Functional Description for detailed clock requirements.
25	RBIAS	AI	Bias Control. Controls operating circuit bias via an external 22.1 kΩ, 1% resistor to ground.
16	RESET	I	Reset. This active Low input is OR'ed with the control register Reset bit (0.15). The LXT970 reset cycle is extended 300 μs (nominal) after Reset is de-asserted.
34	PWRDWN	I	Power-Down. When High, forces LXT970 into power-down mode. This pin is OR'ed with the power-down bit (0.11). Refer to Table 46 for more information.
32, 35, 36	N/C	-	No Connection. Leave open.

1. Pin numbers apply to both package types (PQFP and LQFP).
2. I/O Column Coding: I = Input, O = Output, OD = Open Drain, A = Analog.

Table 7: LXT970 Hardware Control Interface Signal Descriptions

Pin# ¹	Pin Name	I/O ²	Signal Description ³																											
8	MF0	I	<p>Multi-Function (MF). Five dual-function configuration inputs. Each pin accepts one of four input voltage levels (VMF1 = 5V, VMF2 = 3.5V, VMF3 = 1.5V, VMF4 = 0V). A simple resistor divider network, as shown in Figure 19 on page 37, is required to establish Mid-level (VMF2 and VMF3) settings. VMF1 and VMF4 (default) settings, can be established with the LXT970 standard power supply and do not require a voltage divider. One voltage divider may be used to drive the MF pins in designs using multiple LXT970s.</p> <p>Each MF pin internally drives two different configuration functions. The first function is to determine the 5-bit address that the LXT970 responds to on the MDIO line (refer to Figures 8 and 9 on page 18). The second function is to determine a particular operational mode of the LXT970. Each MF pin also determines the state of a particular bit in the MII registers. The MDDIS input determines if this effect occurs only at initialization (MDDIS = 0) or continuously (MDDIS = 1). The relationship between the input level and the two configuration functions are shown in Table 8 on page 11 and Table 9 on page 12.</p> <p>The operating functions of MF4, CFG0, and CFG1 change depending on the state of MF0 (Auto-Negotiation enabled or disabled). The functions of MF4, CFG1 and FDE are interrelated.</p> <p>The functions of the five MF inputs are as follows:</p> <table border="1" data-bbox="560 1104 1453 1499"> <thead> <tr> <th>Pin</th> <th>MII Address</th> <th>MII Bit</th> <th>Operating Function</th> </tr> </thead> <tbody> <tr> <td>MF0</td> <td>0</td> <td>0.12</td> <td>Auto-Negotiation</td> </tr> <tr> <td>MF1</td> <td>1</td> <td>19.13</td> <td>Repeater Mode (Disabling DTE Mode)</td> </tr> <tr> <td>MF2</td> <td>2</td> <td>19.4</td> <td>5B Symbol Mode (Disabling 4B Nibble Mode)</td> </tr> <tr> <td>MF3</td> <td>3</td> <td>19.3</td> <td>Scrambler Operation (Disabling Scrambler)</td> </tr> <tr> <td rowspan="3">MF4</td> <td rowspan="3">4</td> <td>4.7</td> <td rowspan="2">Auto-Negotiation Enabled - Advertise 100 Mbps</td> </tr> <tr> <td>4.8</td> </tr> <tr> <td>19.2</td> <td>Auto-Negotiation Disabled - Selects TX/FX</td> </tr> </tbody> </table>	Pin	MII Address	MII Bit	Operating Function	MF0	0	0.12	Auto-Negotiation	MF1	1	19.13	Repeater Mode (Disabling DTE Mode)	MF2	2	19.4	5B Symbol Mode (Disabling 4B Nibble Mode)	MF3	3	19.3	Scrambler Operation (Disabling Scrambler)	MF4	4	4.7	Auto-Negotiation Enabled - Advertise 100 Mbps	4.8	19.2	Auto-Negotiation Disabled - Selects TX/FX
Pin	MII Address	MII Bit		Operating Function																										
MF0	0	0.12		Auto-Negotiation																										
MF1	1	19.13		Repeater Mode (Disabling DTE Mode)																										
MF2	2	19.4		5B Symbol Mode (Disabling 4B Nibble Mode)																										
MF3	3	19.3	Scrambler Operation (Disabling Scrambler)																											
MF4	4	4.7	Auto-Negotiation Enabled - Advertise 100 Mbps																											
		4.8																												
		19.2	Auto-Negotiation Disabled - Selects TX/FX																											
7	MF1																													
6	MF2																													
5	MF3																													
4	MF4																													

1. Pin numbers apply to both package types (PQFP and LQFP).

2. I/O Column Coding: I = Input, O = Output, OD = Open Drain, A = Analog.

3. FDE, CFG0, and CFG1 are affected by the MDDIS input pin. When MDDIS = 0, these inputs determine only the initial state of the function they control. When MDDIS = 1, these inputs provide continuous hardware control over their corresponding functions.

Table 7: LXT970 Hardware Control Interface Signal Descriptions – continued

Pin# ¹	Pin Name	I/O ²	Signal Description ³
13	FDE	I	<p>Full-Duplex Enable. When A/N is enabled, FDE determines full-duplex advertisement capability in combination with MF4 and CFG1. See Table 9 for details.</p> <p>When A/N is disabled, FDE directly affects full-duplex operation and determines the value of bit 0.8 (Duplex Mode). When FDE is High, F/D is enabled and 0.8 = 1. When FDE is Low, F/D is disabled and 0.8 = 0.</p>
14	CFG0	I	<p>Configuration Control 0. When A/N is enabled, Low to High transition on CFG0 causes auto-negotiate to restart and 0.9 = 1.</p> <p>When A/N is disabled, this input selects operating speed and directly affects bit 0.13. When CFG0 is High, 100 Mbps is selected and 0.13 = 1. If FX Operation is selected, this input must be tied High. When CFG0 is Low, 10 Mbps is selected and 0.13 = 0.</p>
33	CFG1	I	<p>Configuration Control 1. When A/N is enabled, CFG1 determines operating speed advertisement capabilities in combination with MF4. See Table 9 for details.</p> <p>When A/N is disabled, CFG1 enables 10 Mbps link test function and directly affects bit 19.8. When CFG1 is High, 10 Mbps link test is disabled and 19.8 = 1. When CFG1 is Low, 10 Mbps link test is enabled and 19.8 = 0.</p>
<p>1. Pin numbers apply to both package types (PQFP and LQFP). 2. I/O Column Coding: I = Input, O = Output, OD = Open Drain, A = Analog. 3. FDE, CFG0, and CFG1 are affected by the MDDIS input pin. When MDDIS = 0, these inputs determine only the initial state of the function they control. When MDDIS = 1, these inputs provide continuous hardware control over their corresponding functions.</p>			

Table 8 summarizes the relationship between input voltage levels (VMF1, VMF2, VMF3, VMF4) and the configuration function for each of the MF input pins. Each MF pin shows two configuration inputs; configuration function and MII address. The initial setting of the corresponding bit is also shown.

Table 8: MF Pin Function Settings^{1, 3}

Pin	Function	Input Voltage Levels ²			
		VMF1 (5V)	VMF2 (3.5V)	VMF3 (1.5V)	VMF4 (0V)
MF0	MII Address Bit 0	1	1	0	0
	Auto-Negotiation Sets the initial value of bit 0.12	Disabled (0.12 = 0)	Enabled (0.12 = 1)	Enabled (0.12 = 1)	Disabled (0.12 = 0)
MF1	MII Address Bit 1	1	1	0	0
	Repeater / DTE Mode Sets the initial value of bit 19.13	DTE (19.13 = 0)	Repeater (19.13 = 1)	Repeater (19.13 = 1)	DTE (19.13 = 0)
MF2	MII Address Bit 2	1	1	0	0
	Nibble (4B) / Symbol (5B) Mode Sets the initial value of bit 19.4	Nibble (4B) (19.4 = 0)	Symbol (5B) (19.4 = 1)	Symbol (5B) (19.4 = 1)	Nibble (4B) (19.4 = 0)
MF3	MII Address Bit 3	1	1	0	0
	Scrambler Operation Sets the initial value of bit 19.3	Enabled (19.3 = 0)	Bypassed (19.3 = 1)	Bypassed (19.3 = 1)	Enabled (19.3 = 0)
MF4	MII Address Bit 4	1	1	0	0
	If Auto-Negotiate Enabled via MF0, MF4 works in combination with CFG1 to control operating speed and duplex advertisement capabilities via bits 4.5 - 4.8.	See Table 9 for details.			
	If Auto-Negotiate Disabled via MF0, MF4 selects either TX or FX Mode Sets the initial value of bit 19.2	100TX (19.2 = 0)	100FX (19.2 = 1)	100FX (19.2 = 1)	100TX (19.2 = 0)

1. In MDIO Control Mode, the MF pins control only the initial or default value for the respective register bits. In Manual Control mode, the MF pins provide continuous control of the respective register bits.
 2. Input Voltage Levels (VMF1, VMF2, VMF3, VMF4) for MF pins.
 3. See Tables 12 through 14 for operating configuration set-up.

Table 9: LXT970 Auto-Negotiation Operating Speed/Full-Duplex Advertisement Settings

Function	Input Value			MDIO Registers
	MF4	CFG1	FDE	
Advertise all capabilities Ignore FDE	VMF1, VMF4	Low	–	Sets 4.5, 4.6, 4.7 and 4.8 = 1
Advertise 10 Mbps only Advertise FD	VMF1, VMF4	High	High	Sets 4.5 = 1 Sets 4.7 and 4.8 = 0 Sets 4.6 = 1
Advertise 10 Mbps only Do Not Advertise FD			Low	Sets 4.5 = 1 Sets 4.7 and 4.8 = 0 Sets 4.6 = 0
Advertise 100 Mbps only Advertise FD	VMF2, VMF3	Low	High	Sets 4.7 = 1 Sets 4.5 and 4.6 = 0 Sets 4.8 = 1
Advertise 100 Mbps only Do Not Advertise FD			Low	Sets 4.7 = 1 Sets 4.5 and 4.6 = 0 Sets 4.8 = 0
Advertise 10/100 Mbps Advertise FD	VMF2, VMF3	High	High	Sets 4.5 and 4.7 = 1 Sets 4.6 and 4.8 = 1
Advertise 10/100 Mbps Do Not Advertise FD			Low	Sets 4.5 and 4.7 = 1 Sets 4.6 and 4.8 = 0

FUNCTIONAL DESCRIPTION

Introduction

The LXT970 Fast Ethernet Transceiver is a physical layer (PHY) device that supports both 10 and 100 Mbps Ethernet networks. It provides all the functions necessary to build an IEEE 802.3 compliant solution. The LXT970 can directly drive a twisted-pair cable for up to 100 meters. The LXT970 also provides a pseudo-ECL interface for driving a 100BASE-FX fiber connection.

On power-up, the LXT970 can use auto-negotiation with parallel detection to automatically determine line operating conditions. If the PHY device on the other side of the link supports auto-negotiation, the LXT970 will auto-negotiate with it using Fast Link Pulse (FLP) bursts. If the PHY partner does not support auto-negotiation, the LXT970 will automatically detect the presence of either link pulses (10 Mbps PHY) or Idle symbols (100 Mbps PHY) and set its operating speed accordingly. When the line speed selection is made via the parallel detection method, the duplex mode will be set to half. The user may later select full-duplex operation by subsequent writes to the appropriate MDIO register. Line operation can also be set using the Hardware Control Interface.

The LXT970 interfaces to a 10/100 MAC through the MII interface. The LXT970 performs all functions of the Physical Coding Sublayer (PCS) and Physical Media

Attachment (PMA) sublayer as defined in the IEEE 802.3 100BASE-X specification. It also performs all functions of the Physical Media Dependent (PMD) sublayer for 100BASE-TX connections. The MII speed is automatically set once line operating conditions have been determined.

See Figure 2 for a typical Network Interface Card (NIC). The LXT970 supports NIC, repeater and switch applications. It provides half- and full-duplex operation at 100 Mbps and 10 Mbps.

NOTE

The LXT970 supports the 802.3 MDIO register set. Specific bits in the registers are referenced using an "X.Y" notation, where X is the register address (0-6 or 16-20) and Y is the bit number (0:15).

Figure 2: Network Interface Card (NIC) Application

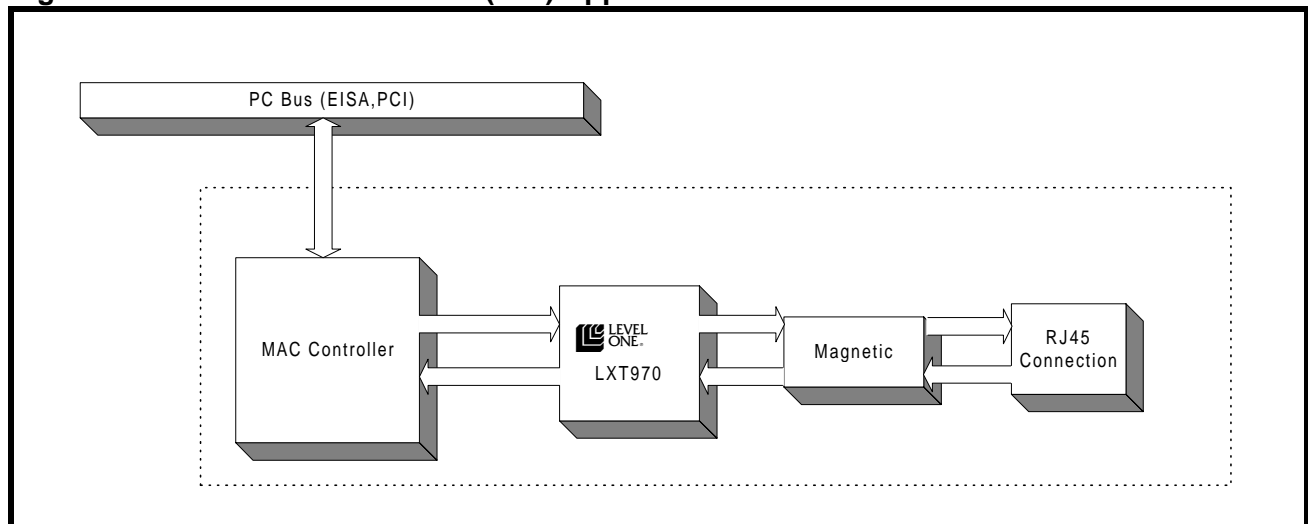

Interfaces (Network Media/ Protocol Support)

The LXT970 provides the following interfaces:

- A Twisted-Pair Interface which directly supports 100BASE-TX and 10BASE-T applications.
- A pseudo-ECL (PECL) Fiber Interface which supports 100BASE-FX applications through an external fiber transceiver.
- An Media Independent Interface (MII) for interfacing 10/100 Media Access Controllers (MACs).
- A Hardware Control Interface to configure various operating characteristics.

Twisted-Pair Interface

The twisted-pair interface directly supports both 100BASE-TX (100TX) and 10BASE-T (10T) applications. The interface is capable of directly driving an RJ45 interface through magnetics and termination resistors. The interface uses two signal pairs - one for transmit and one for receive. A third output, TREF, connects to the center-tap of the transmit transformer. The same signal pairs, magnetics, and termination resistors are used for both 10 and 100 Mbps operation.

When the LXT970 is operating as a 100 Mbps device, it transmits and receives a 125 Mbps, 5B-encoded, scrambled MLT-3 waveform on this interface. The MLT-3 waveform is continuous. When there is no data to send, "Idle" symbols are sent and received.

When the LXT970 is operating as a 10 Mbps device, it transmits and receives 10 Mbps Manchester-encoded data. The waveform is not continuous. When there is no data to send, the line is left in an idle state. Link pulses are transmitted periodically to keep the link up.

The LXT970 supports both fixed operation and auto-negotiation with parallel detection on this interface. Fixed operation allows the designer to specify the line speed and duplex mode. With auto-negotiation enabled, the LXT970 will automatically determine line speed and duplex state by listening to its link partner.

A 4 k Ω passive load is always present across the twisted-pair inputs. When enabled, the twisted-pair inputs are actively biased to approximately 2.8V.

In applications where the twisted-pair interface is not used, the inputs and outputs may be left unconnected.

The twisted-pair interface is disabled in power-down mode, when the fiber interface is selected, or when the transmit disconnect (bit 19.0) is set. When the twisted-pair interface is disabled its outputs are tristated and inputs are unbiased.

Fiber Interface

The pseudo-ECL fiber interface is suitable for driving 100BASE-FX applications through an external fiber transceiver. This interface consists of a transmit and receive pair. The LXT970 sends and receives a continuous 125 Mbps, 5B-encoded NRZI stream on this interface. Scrambling and MLT-3 are not used in fiber connections.

There is no industry standard for auto-negotiation on 100BASE-FX. The LXT970 only supports forced operation on the fiber interface. The LXT970 does not support 10 Mbps fiber (10FL) applications.

The LXT970 does not support the signal detect function. However, the PMA functions of the LXT970 guarantee that it will detect invalid link conditions and break down a link, even without the signal detect function.

In applications where the fiber interface is not used, the inputs and outputs may be left unconnected. The fiber interface is disabled in power-down mode and when the twisted-pair interface is enabled. When the fiber interface is disabled its outputs are pulled to ground.

MII Interface

The LXT970 implements the Media Independent Interface (MII) as defined in the IEEE 802.3. This interface consists of a data interface and a management interface as shown in Figure 3. The data interface is used for exchanging data between a 10/100 802.3 compliant Ethernet Media Access Controller (MAC) and the LXT970. The management portion of the interface allows network management functions to control and monitor the LXT970.

Figure 3: MII Interface

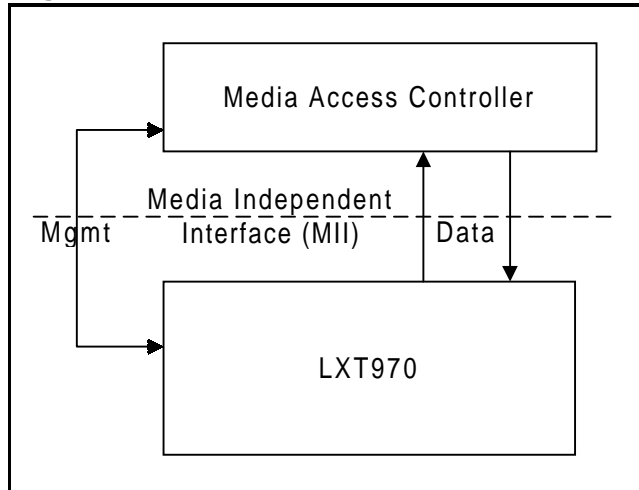

MII Data Interface

Figure 4 shows the data portion of the MII interface. Separate channels are provided for transmitting data from the MAC to the LXT970 (TXD), and for receiving data (RXD) from the line.

Each channel has its own clock, data bus and control signals. The LXT970 supplies both clock signals as well as separate outputs for carrier sense and collision.

Normal data transmission across the MII is implemented in 4-bit wide nibbles known as 4B Nibble Mode. In 5B Symbol Mode, a fifth bit allows 5-bit symbols to be sent across the MII. Details of 4B Nibble and 5B Symbol Modes can be found in the 100 Mbps Operation section on page 25.

Figure 4: MII Data Interface

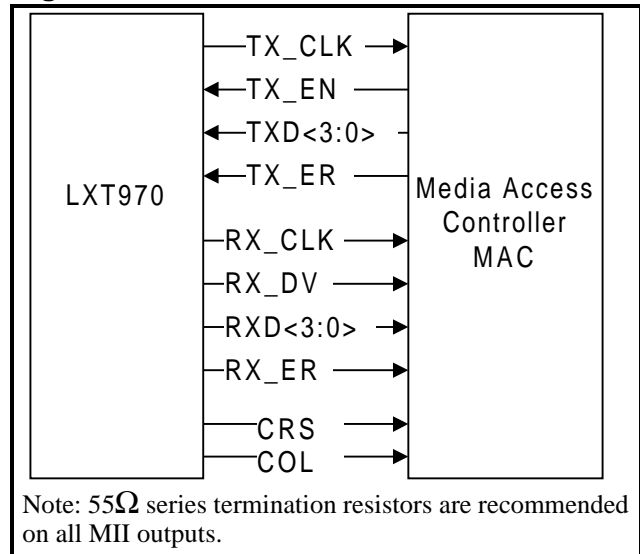

Transmit Clock

The transmit clock (TX_CLK) is normally generated by the LXT970 from the master 25 MHz reference source at the XI input. However, when the XI input is grounded, TX_CLK becomes the master reference clock input.

The transmit data and control signals must always be synchronized to TX_CLK by the MAC. The LXT970 normally samples these signals on the rising edge of TX_CLK. However, Advanced TX_CLK Mode is available by setting MII register bit 19.5=1. In this mode, the LXT970 samples the transmit data and control signals on the falling edge of TX_CLK. Further details of clock modes can be found in the Operating Requirements section on page 21.

Receive Clock

The source of the receive clock varies depending on operating conditions. For 100BASE-TX and 100BASE-FX links, receive clock is continuously recovered from the line. If the link goes down, and auto-negotiation is disabled, receive clock operates off the master input clock (XI or TX_CLK).

For 10T links, receive clock is recovered from the line while carrier is active and operates from the master input clock when the line is idle.

The LXT970 synchronizes the receive data and control signals to RX_CLK. The LXT970 always changes these signals on the falling edge of RX_CLK in order to stabilize the signals at the rising edge of the clock with 10ns setup and hold times.

Transmit Enable

The MAC must assert TX_EN the same time as the first nibble of preamble, and de-assert TX_EN after the last bit of the packet.

Receive Data Valid

The LXT970 asserts RX_DV when it receives a valid packet. Timing changes depend on line operating speed and MII mode:

- For 100TX and 100FX links with the MII in 4B mode, RX_DV is asserted from the first nibble of preamble to the last nibble of the data packet.
- For 100TX and 100FX links with the MII in 5B mode, RX_DV is asserted starting with the /K symbol and ending with the /T symbol.
- For 10T links, the entire preamble is truncated. RX_DV is asserted with the first nibble of the SFD “5D” and remains asserted until the end of the packet.

Error Signals

In 100TX mode, when the LXT970 receives an errored symbol from the network, it asserts RX_ER and drives “1110” (4B) or “01110” (5B) on the RXD pins.

When the MAC asserts TX_ER, the LXT970 will drive “H” symbols out on the line.

There are no error functions in 10T mode.

Carrier Sense

Carrier sense (CRS) is an asynchronous output. It is always generated when a packet is received from the line and in some modes when a packet is transmitted.

On transmit CRS is asserted on a 10T, half-duplex link when MII Register 19.11=0 (default state), or on any 100 Mbps half-duplex link. Carrier sense is not generated on transmit when the link operation is full-duplex, or with 10T half-duplex links when 19.11=1.

Usage of CRS for Interframe Gap (IFG) timing is *not* recommended for the following reasons:

- De-assertion time for CRS is slightly longer than assertion time. This causes IFG intervals to appear somewhat shorter to the MAC than it actually is on the wire.
- CRS de-assertion is not aligned with TX_EN de-assertion on transmit loopbacks in half-duplex mode.

Operational Loopback

Operational loopback is provided for 10 Mbps half-duplex links when bit 19.11 = 0. Data transmitted by the MAC will be looped back on the receive side of the MII. Operational loopback is not provided for 100 Mbps links, full-duplex links, or when 19.11 = 1.

Test Loopback

A test loopback function is provided for diagnostic testing of the LXT970. During test loopback, twisted-pair and fiber interfaces are disabled. Data transmitted by the MAC is internally looped back by the LXT970 and returned to the MAC.

Test loopback is available for 100 Mbps and 10 Mbps operation. Loopback paths for the two modes of operation are shown in Figure 5.

Test loopback is enabled by setting bit 0.14 = 1 (loopback), bit 0.8 = 1 (full-duplex), and bit 0.12 = 0 (disable auto-negotiation). The desired mode of operation for test loopback is set using bits 0.13 and 19.2 as shown in Table 10.

Table 10: Test Loopback Operation

Mode of Operation	Bit	
	19.2	0.13
10 Mbps Test Loopback	0	0
100 Mbps Test Loopback	1	1

1. Bit 0.14 = 1, bit 0.8 = 1, and 0.12 = 0 must also be set to enable Test Loopback.

Figure 5: Loopback Paths

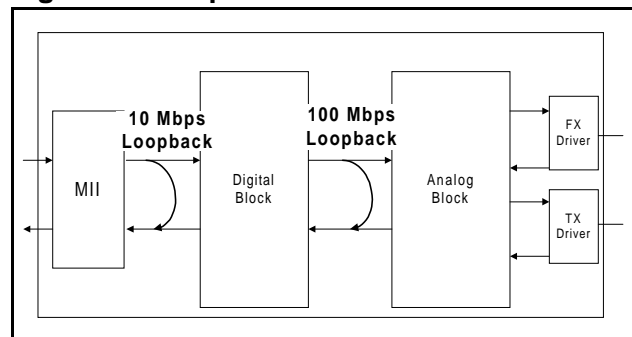

Collision

The LXT970 asserts its collision signal, asynchronously to any clock, whenever the line state is half-duplex and the transmitter and receiver are active at the same time. Table 11 summarizes the conditions for assertion of carrier sense, collision, and data loopback signals.

Repeater Mode

The LXT970 MII normally operates in DTE Mode (19.13 = 0). An alternative operating mode is available for repeater applications (19.13 = 1).

In Repeater Mode, the Carrier Sense (CRS) and Tristate (TRSTE) signals request and grant bus access. The TRSTE pin controls only the receive channel of the MII (RX_DV, RX_ER, RX_CLK, and RXD).

As shown in Figure 6, a central Repeater State Machine (RSM) is required to perform arbitration and determine which LXT970 will drive the MII Data Interface. The RSM is responsible for enforcing collisions, and ensuring packets are not transmitted to the port they were received from. This is accomplished by supplying each LXT970 with individual TX_EN outputs. Although repeater operation is half-duplex, the LXT970 operates the MII as a full-duplex interface in Repeater Mode. CRS is generated only on receive and Collision (COL) is never generated.

In Repeater Mode, Carrier Sense (CRS) and Tristate (TRSTE) signals request and grant bus access. The TRSTE pin controls only the receive channel of the MII (RX_DV, RX_ER, RX_CLK, and RXD).

Repeater Mode is normally used with Slave Clock Mode (XI = GND and TX_CLK is an input).

Figure 6: Repeater Block Diagram

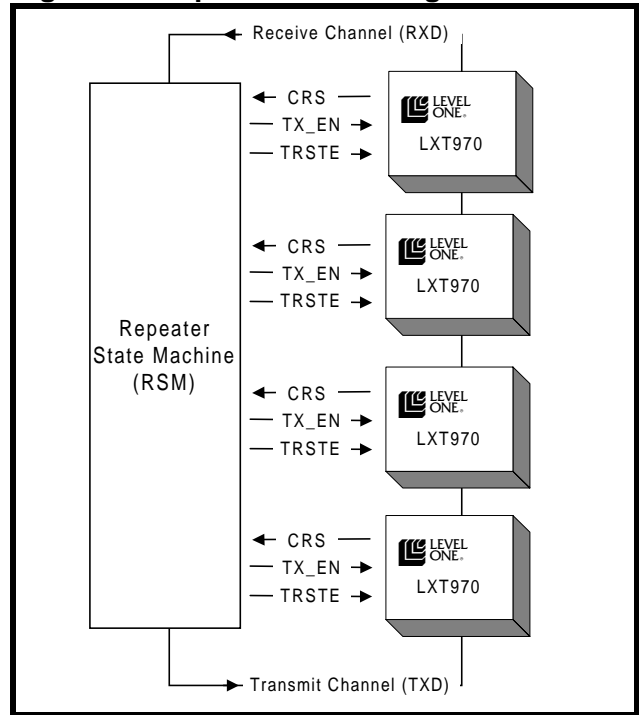

Table 11: Carrier Sense, Loopback, and Collision Conditions

Speed & Duplex Condition	Carrier Sense	Loopback	Collision
Full-Duplex at 10 Mbps or 100 Mbps Repeater Mode	Receive only	None	None
100 Mbps, Half-Duplex	Transmit or Receive	None	Transmit and Receive
10 Mbps, Half-Duplex, 19.11 = 0	Transmit or Receive	Yes	Transmit and Receive
10 Mbps, Half-Duplex, 19.11 = 1	Receive only	None	Transmit and Receive

MII Management Interface

The LXT970 supports the IEEE 802.3 MII Management Interface also known as the Management Data Input/Output (MDIO) Interface. This interface allows upper-layer devices to monitor and control the state of the LXT970. The MDIO interface consists of a physical connection, a specific protocol which runs across the connection, and an internal set of addressable registers. The physical interface consists of a data line (MDIO) and clock line (MDC), a control line (MDDIS) and an optional interrupt line (MDINT). The LXT970 can signal an interrupt using the MDIO signal as shown in Figure 7. The user can also assign a separate pin for this function. If bit 17.1 = 1, pin 2 (FDS/MDINT) will be used as an MDINT pin.

The protocol allows one controller to communicate with multiple LXT970 devices. Each LXT970 is assigned an MII address between 0 and 31 by the MF inputs. The timing for the MDIO Interface is shown in Table 43 on page 54. Read and write operations are shown in Figures 8 and 9. Operation of this interface is controlled by the MDDIS input pin. When MDDIS is High, the MDIO operates as a read-only interface. When MDDIS is Low, read and write are enabled.

The LXT970 supports twelve 16-bit MDIO registers. Registers 0-6 are required and their functions are specified by the IEEE 802.3 specification. Additional registers are included for expanded functionality. The MDIO Register set for the LXT970 is described in Tables 46 through 57. Specific bits in the registers are referenced using an “X.Y” notation, where X is the register number (0-6 or 16-20) and Y is the bit number (0-15).

MII Management Interrupt

The MDINT/FDS pin functions as a management data interrupt on the MII when 17.1 = 1. An active Low on this pin indicates a status change on the LXT970. The interrupt is activated when changes are made to the following conditions:

- Link Status
- Duplex Status

This interrupt is cleared by sequentially reading Register 1 and Register 18.

Figure 7: MDIO Interrupt Signaling

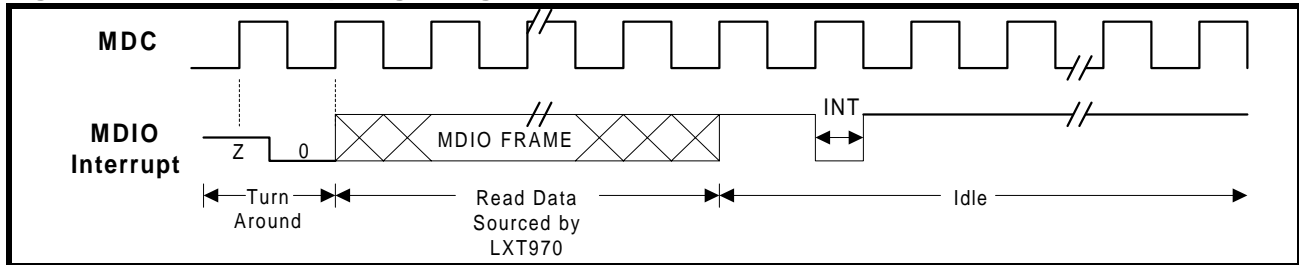

Figure 8: Management Interface - Read Frame Structure

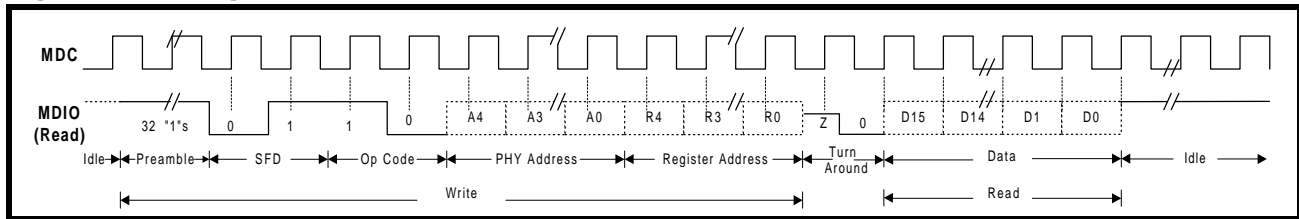
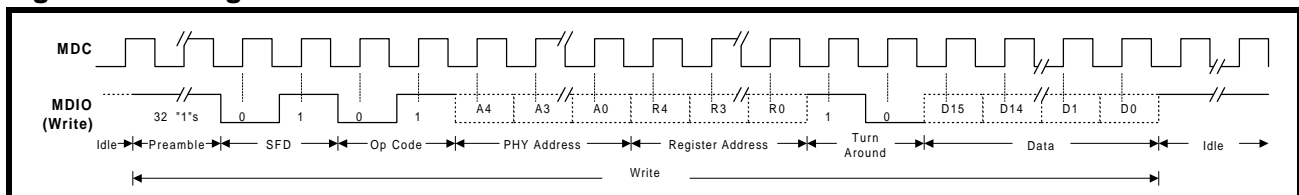

Figure 9: Management Interface - Write Frame Structure



Hardware Control Interface

The Hardware Control Interface consists of MF<4:0>, CFG <1:0> and FDE input pins. This interface is used to configure operating characteristics of the LXT970 and to determine the MDIO Address. When MDDIS is Low, the Hardware Control Interface provides initial values for the MDIO registers, and then passes control to the MDIO Interface.

When MDDIS is High, the Hardware Control Interface provides continuous control over the LXT970. Individual chip addressing allows multiple LXT970 devices to share the MII in either mode. Tables 12, 13, and 14 show how to set up the desired operating configurations using the Hardware Control Interface.

Table 12: Configuring the LXT970 via Hardware Control

Desired Configuration	Pin Name	Voltage Level	MDIO Registers
Auto-Negotiation Enabled ¹	MF0	VMF2, VMF3	0.12 = 1
Auto-Negotiation Disabled ²	MF0	VMF1, VMF4	0.12 = 0
Normal Operation (DTE Mode, Nibble Mode, Scrambler Enabled)	MF1 MF2 MF3	VMF1, VMF4	19.13 = 0 19.4 = 0 19.3 = 0
Repeater Mode	MF1	VMF2, VMF3	19.13 = 1
Symbol Mode	MF2	VMF2, VMF3	19.4 = 1
Scrambler Bypass Mode	MF3	VMF2, VMF3	19.3 = 1

1. Refer to Table 13 for Hardware Control Interface functions available when auto-negotiation is enabled.
2. Refer to Table 14 for Hardware Control Interface functions available when auto-negotiation is disabled.

Table 13: LXT970 Operating Configurations / Auto-Negotiation Enabled

Desired Configuration ^{1,2}	Input Value			MDIO Registers			
	MF4	CFG1	FDE	4.5	4.6	4.7	4.8
Advertise All	VMF1, VMF4	Low	Ignore	1	1	1	1
Advertise 100 HD	VMF2, VMF3	Low	Low	0	0	1	0
Advertise 100 HD/FD	VMF2, VMF3	Low	High	0	0	1	1
Advertise 10 HD	VMF1, VMF4	High	Low	1	0	0	0
Advertise 10 HD/FD	VMF1, VMF4	High	High	1	1	0	0
Advertise 10/100 HD	VMF2, VMF3	High	Low	1	0	1	0

1. Refer to Table 12 for basic configurations.
2. Refer to Table 14 for Hardware Control Interface functions available when auto-negotiation is disabled.

Table 14: LXT970 Operating Configurations / Auto-Negotiation Disabled

Desired Configuration ^{1,2}	Pin Name	Input Value	MDIO Registers
Force 100FX Operation	MF4	VMF2, VMF3	19.2 = 1
	CFG0	High	0.13 = 1
	MF3	VMF1, VMF4	19.3 = 0
Force 100TX Operation	MF4	VMF1, VMF4	19.2 = 0
	CFG0	High	0.13 = 1
Force 10T Operation	MF4	VMF1, VMF4	19.2 = 0
	CFG0	Low	0.13 = 0
Force full-duplex Operation	FDE	High	0.8 = 1
Disable 10T Link Test	CFG1	High	19.8 = 1
Enable 10T Link Test	CFG1	Low	19.8 = 0
1. Refer to Table 12 for basic configurations. 2. Refer to Table 13 for Hardware Control Interface functions available when auto-negotiation is enabled.			

Operating Requirements

Power Supply Requirements

The LXT970 requires a 5V power supply. Power should be supplied from a single source to the VCC, VCCA, VCCT, and VCCR power pins. A ground return path must be provided to the GND, GNDA, GNDT, and GNDR pins. As a matter of practice, the power supply should be as clean as possible. Filtering is recommended for the analog power pins (VCCA, VCCT, VCCR) at least in the initial design. Consult the Design Recommendations section for details. A decoupling capacitor is recommended between each VCC pin and its respective GND, placed as close to the device as possible.

Optional MII Power Supply

The MII may be powered by either a 3.3V or 5V source via the VCCIO pin. To avoid power sequencing issues, the VCCIO pin should be supplied from the same source used to power the other side of the MII interface. When VCCIO is supplied with 3.3V, the MII inputs are not tolerant of 5V signal levels. The MDIO and MDC pins must be operated at the same voltage as the rest of the MII interface.

Reference Clock Requirements

The LXT970 requires a continuous, stable reference clock. There are two clock modes, Master Clock Mode and Slave Clock Mode. Depending on the mode of operation, the clock may be supplied at the crystal oscillator pins (XI, XO), or at the Transmit Clock pin (TX_CLK). See Table 26 for input clock requirements.

Master Clock Mode

The Master Clock mode is recommended in most Network Interface Cards (NICs) and switch applications. In Master Clock mode the LXT970 is the master clock source for data transmission, and requires a 25 MHz reference signal at XI. The reference clock may be supplied either from a crystal oscillator or from a digital clock circuit. It must have a frequency of 25 MHz +/- 100 ppm, and a 40/60 duty cycle or better. It must also meet CMOS voltage levels ($V_{OH} > 3.2V$).

In Master Clock Mode, TX_CLK is an output and the LXT970 automatically sets the speed of TX_CLK to match line conditions. If the line is operating at 100 Mbps, TX_CLK will be set to 25 MHz. If the line is operating at 10 Mbps, TX_CLK will be set to 2.5 MHz.

External Crystal

A crystal is typically used in NIC applications. If a crystal oscillator is used, it should be fundamental-mode and parallel-resonant, with a drive capacity of at least 7 pF. It should be attached between the XI and XO pins. Compensating capacitors should be added between each leg and digital ground. The correct value to use is the nominal drive capacity of the crystal minus 3 pF (input capacitance of the XI and XO pins). One crystal can be used to drive two LXT970s. Connect the XO pin of only one 970 to one side of the crystal, and connect the other side to both XI pins. Calculate compensation accordingly.

External Clock

An external 25 MHz clock source, rather than a crystal, is frequently used in switch applications. When a clock is supplied to XI, XO is left open.

TX Clock Advance Mode

When operating in master clock mode under MDIO control, the user can advance the transmit clock relative to TXD<4:0> and TX_ER. When TX_CLK Advance is selected, the LXT970 clocks TXD data in on the falling edge of TX_CLK, instead of the rising edge.

This mode provides an increase in timing margins of TXD, relative to TX_CLK. TX_CLK Advance is enabled when bit 19.5 = 1.

Slave Clock Mode

The Slave Clock mode is typically used for repeater applications, where the LXT970 is not the master clock source for data transmissions. In Slave Clock Mode a digital clock circuit with TTL levels ($V_{IH} > 2.0V$) must supply the TX_CLK input. The frequency may be either 25 MHz or 2.5 MHz. Either frequency can be used during auto-negotiation. However, once link is established, the supplied frequency must match the link state. A 25 MHz clock must be supplied for correct operation of a 100TX or 100FX link, and a 2.5 MHz clock must be supplied for correct operation of a 10T link. In Slave Clock mode XI is connected to ground and XO is left open.

Bias Circuit Requirements

A 22.1 k Ω 1% resistor must be tied between the RBIAS input and ground. High speed signals should be kept away from this resistor; follow the layout recommendations given in the Design Recommendations section on page 35.

Initialization

At power-up or reset, the LXT970 performs the initialization sequence shown in Figure 10.

Control Mode Selection

Mode control selection is provided via the MDDIS pin as shown in Table 15. When MDDIS is High, the LXT970 enters Manual Control Mode. When MDDIS is Low, MDIO Control Mode is enabled.

MDIO Control Mode

In the MDIO Control mode, the LXT970 reads the Hardware Control Interface pins to set the initial (default) values of the MDIO registers. Once the initial values are set, bit control reverts to the MDIO interface.

Manual Control Mode

In the Manual Control Mode, LXT970 disables direct write operations to the MDIO registers via the MDIO Interface. The LXT970 continuously monitors the Hardware Control Interface pins and updates the MDIO registers accordingly.

Table 15: Mode Control Settings

Mode	MDDIS Pin 15	RESET Pin 16	PWRDWN Pin 34
MDIO Control	Low	High	Low
Manual Control	High	High	Low
Reset	-	Low	Low
Power-Down	-	-	High

Link Configuration

When the LXT970 is first powered on, reset, or encounters a link failure state, it must determine the line speed and operating conditions to use for the network link. The LXT970 first checks the MDIO registers (initialized via the Hardware Control Interface or MDIO Interface) for operating instructions. Both control modes allow the user to either force the LXT970 to a specific configuration or allow it to auto-negotiate the optimum configuration with its link partner.

Manual Configuration

The LXT970 can be manually configured to force operation in the following modes:

- 100FX, full-duplex
- 100FX, half-duplex
- 100TX, full-duplex
- 100TX, half-duplex
- 10T, full-duplex
- 10T, half-duplex

Refer to Tables 12 through 14 in the Hardware Control Interface discussion for specific manual configuration settings.

Figure 10: LXT970 Initialization Sequence

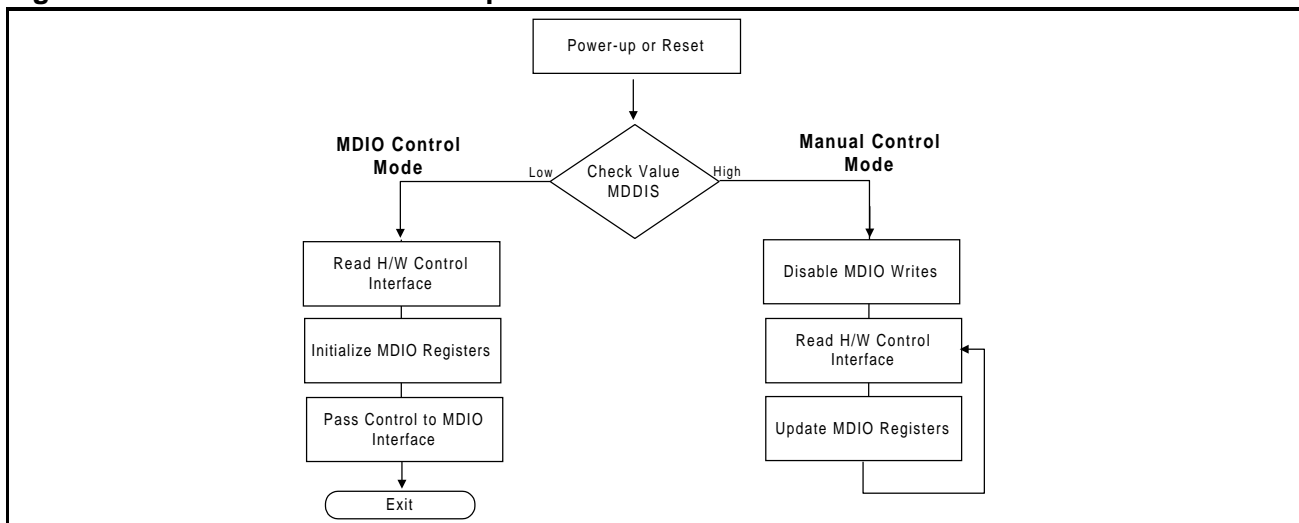

Auto-Negotiation/Parallel Detection

With auto-negotiation enabled at power-up or reset, the LXT970 attempts to establish link operating conditions with its partner by sending Fast Link Pulse (FLP) bursts.

If the link partner is also capable of auto-negotiation, the two devices exchange FLP bursts to communicate their capabilities to each other. Each side finds the highest common capabilities that both sides can support and then begins operating in that mode.

If the link partner is not capable of auto-negotiation, it will transmit either 10 Mbps Normal Link Pulses (NLP) or 100 Mbps Idle symbols. When the LXT970 detects either NLPs or Idle symbols, it automatically configures to match the detected operating speed in half-duplex mode. This ability allows the LXT970 to communicate with devices that do not support auto-negotiation.

Controlling Auto-Negotiation

When auto-negotiation is controlled by software, the following steps are recommended:

- After a reset or power-up (initial or from power-down mode), the power-down recovery time (refer to Table 44 on page 55) must be exhausted before proceeding.
- Set MDIO Register 4 advertisement capabilities before setting MDIO bit 0.12 = 1 to enable auto-negotiation.

Figure 11: Auto-Negotiation Operation

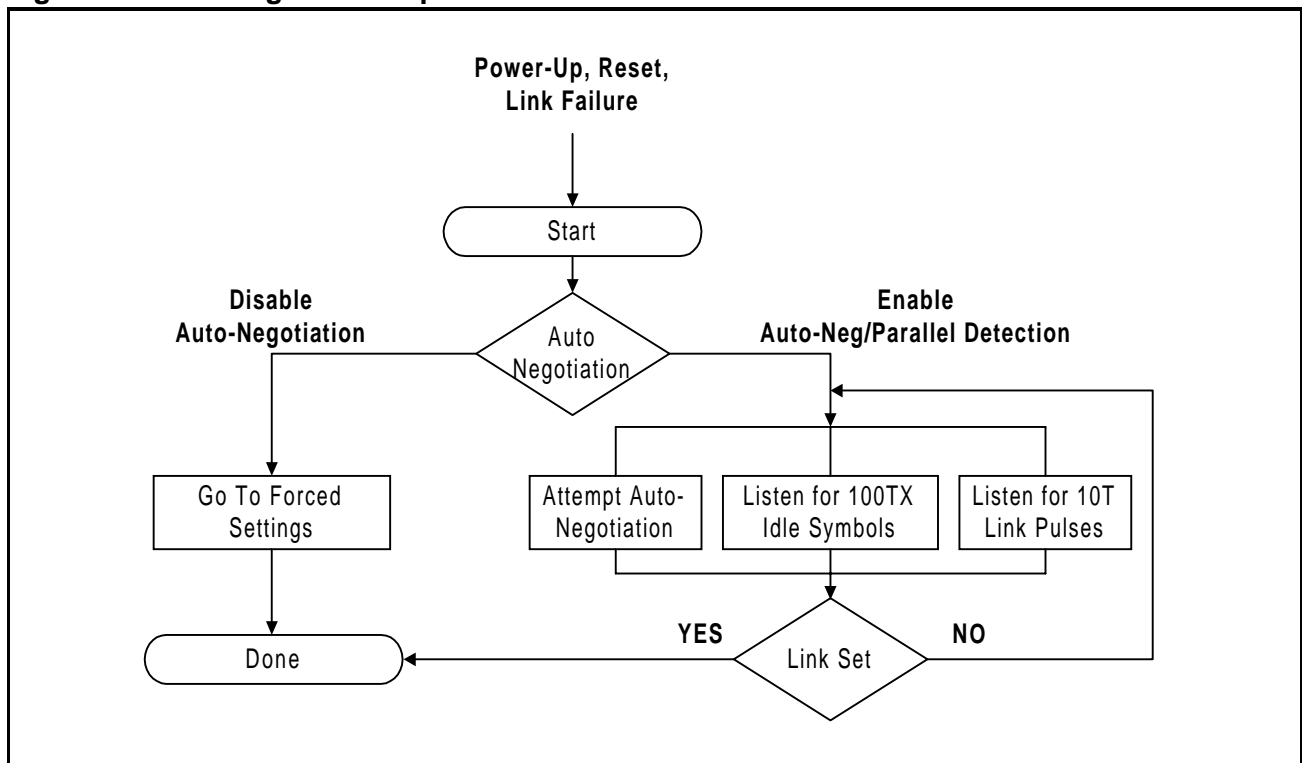

Monitoring Operational Status

Monitoring Status via MII Registers

The Chip Status Register (Table 57 on page 66) provides a convenient indication of several status conditions:

- Bit 20.13 is set to 1 once the link is established
- Bits 20.12 and 20.11 indicate the link speed and duplex condition
- Bits 20.9 and 20.8 indicate the progress and status of auto-negotiation

Refer to the Register Definitions section on page 56 for additional details on specific registers.

Monitoring Status via Indicator Pins

The LEDS, LEDR, LEDT, LEDL, and LEDC pins are CMOS digital outputs that can be used to drive LEDs. These pins along with the FDS/MDINT output, can also be used to externally monitor the status of the LXT970. The following notes apply to the FDS/MDINT and LED pins:

- LEDR, LEDT and LEDC pulse Low to indicate receive, transmit, and collision activity respectively. When the LXT970 asserts these signals, it automatically extends them for 100 ms.
- LEDL indicates link status and LEDS indicates link speed. LEDL and LEDS are active Low.
- In its default state (17.1 = 0), the MDINT/FDS output indicates duplex condition. FDS is active High.

Table 16 shows the state of the LXT970 according to the status of LEDL, LEDS, and FDS pins.

Table 16: LXT970 Status using FDS/LED Pins

LXT970 State	Pin Status		
	LEDL	LEDS	FDS
During Power-up	High	High	Low
During Auto-Negotiation or Link Failure	High	High	Low
Link-up; 100 Mbps; full-duplex	Low	Low	High
Link-up ; 100 Mbps; half-duplex	Low	Low	Low
Link-up ; 10 Mbps; full-duplex	Low	High	High
Link-up ; 10 Mbps; half-duplex	Low	High	Low

100BASE-X Operation

100BASE-X MII Operations

The MAC exchanges data with the LXT970 over the MII interface. The LXT970 converts the digital data from the MAC into an analog waveform that is transmitted to the network via the copper (TX) or fiber (FX) interface. The LXT970 converts analog signals received from the network into a digital format and sends them to the MAC via the MII. Refer to the MII discussion on 15 for details on MII control and data signals.

The 100BASE-X protocol specifies the use of a 5-bit symbol code on the network media. However, data is normally transmitted across the MII interface in 4-bit nibbles. The LXT970 incorporates a 4B/5B encoder/decoder circuit that translates 4-bit nibbles from the MII into 5-bit symbols for the 100BASE-X connection, and translates 5-bit symbols from the 100BASE-X connection into 4-bit nibbles for the MII. Figure 13 shows the data conversion flow from nibbles to symbols. Table 17 shows 4B/5B symbol coding (not all symbols are valid).

In some applications it may be desirable to bypass the 4B/5B encoder/decoder circuit, and operate the MII as a 5-bit symbol mode interface. The LXT970 provides additional lines in both the receive and transmit channels (RXD4 & TXD4) to accommodate MACs that accept 5-bit symbols.

100BASE-X Network Operations

During 100BASE-X operation, the LXT970 transmits and receives 5-bit symbols across the network link. Figure 12 shows the structure of a standard frame packet. When the MAC is not actively transmitting data, the LXT970 sends out Idle symbols on the line.

In 100TX mode, the LXT970 scrambles the data using a polynomial key, and transmits it to the network using MLT-3 line code. The MLT-3 signals received from the network are descrambled and decoded by the LXT970, and sent across the MII to the MAC.

In 100FX mode, the LXT970 transmits and receives NRZI signals across the pseudo-ECL interface. An external 100FX transceiver module is required to complete the fiber connection. To enable 100FX operation, auto-negotiation must be disabled and FX selected.

Figure 12: 100BASE-TX Frame Structure

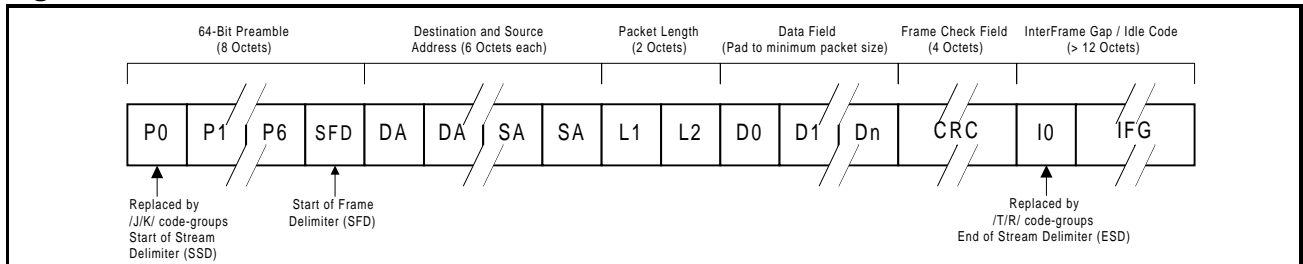

Figure 13: 100BASE-TX Data Flow

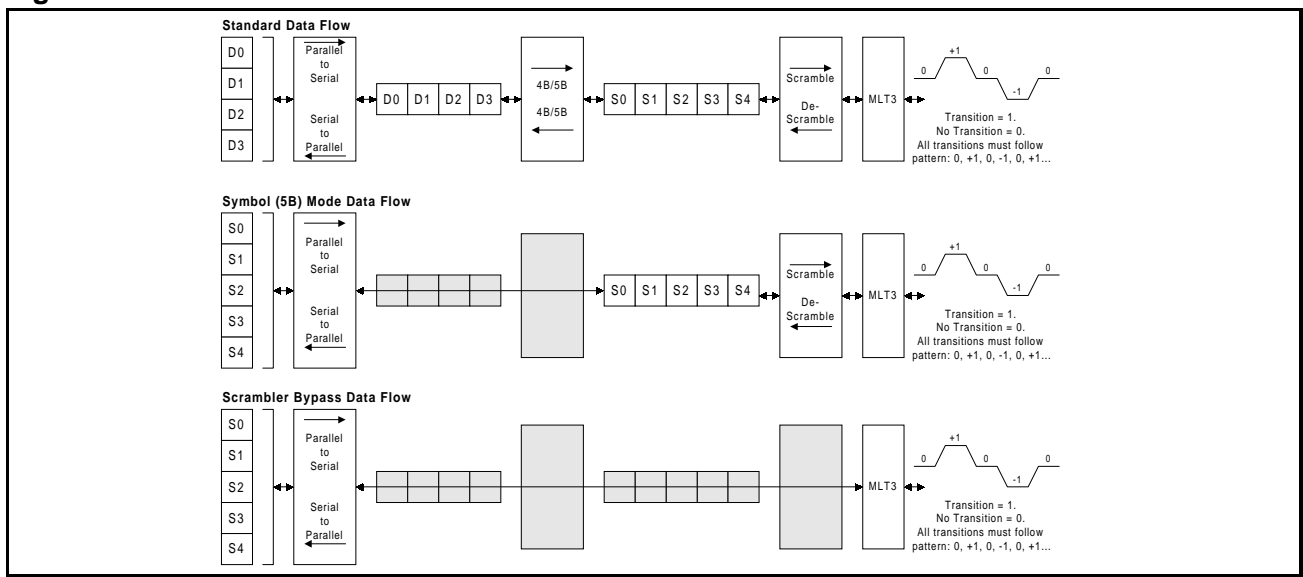

Table 17: 4B/5B Coding

Code Type	4B Code 3 2 1 0	Name	5B Symbol 4 3 2 1 0	Interpretation
DATA	0 0 0 0	0	1 1 1 1 0	Data 0
	0 0 0 1	1	0 1 0 0 1	Data 1
	0 0 1 0	2	1 0 1 0 0	Data 2
	0 0 1 1	3	1 0 1 0 1	Data 3
	0 1 0 0	4	0 1 0 1 0	Data 4
	0 1 0 1	5	0 1 0 1 1	Data 5
	0 1 1 0	6	0 1 1 1 0	Data 6
	0 1 1 1	7	0 1 1 1 1	Data 7
	1 0 0 0	8	1 0 0 1 0	Data 8
	1 0 0 1	9	1 0 0 1 1	Data 9
	1 0 1 0	A	1 0 1 1 0	Data A
	1 0 1 1	B	1 0 1 1 1	Data B
	1 1 0 0	C	1 1 0 1 0	Data C
	1 1 0 1	D	1 1 0 1 1	Data D
	1 1 1 0	E	1 1 1 0 0	Data E
	1 1 1 1	F	1 1 1 0 1	Data F
IDLE	undefined	I ¹	1 1 1 1 1	Idle. Used as inter-stream fill code
CONTROL	0 1 0 1	J ²	1 1 0 0 0	Start-of-Stream Delimiter (SSD), part 1 of 2
	0 1 0 1	K ²	1 0 0 0 1	Start-of-Stream Delimiter (SSD), part 2 of 2
	undefined	T ³	0 1 1 0 1	End-of-Stream Delimiter (ESD), part 1 of 2
	undefined	R ³	0 0 1 1 1	End-of-Stream Delimiter (ESD), part 2 of 2
INVALID	undefined	H ⁴	0 0 1 0 0	Transmit Error. Used to force signaling errors
	undefined	Invalid	0 0 0 0 0	Invalid
	undefined	Invalid	0 0 0 0 1	Invalid
	undefined	Invalid	0 0 0 1 0	Invalid
	undefined	Invalid	0 0 0 1 1	Invalid
	undefined	Invalid	0 0 1 0 1	Invalid
	undefined	Invalid	0 0 1 1 0	Invalid
	undefined	Invalid	0 1 0 0 0	Invalid
	undefined	Invalid	0 1 1 0 0	Invalid
	undefined	Invalid	1 0 0 0 0	Invalid
undefined	Invalid	1 1 0 0 1	Invalid	

1. The /I/ (Idle) code-group is sent continuously between frames.
2. The /J/ and /K/ (SSD) code-groups are always sent in pairs; /K/ follows /J/.
3. The /T/ and /R/ (ESD) code-groups are always sent in pairs; /R/ follows /T/.
4. An /H/ (Error) code-group is used to signal an error condition.

10BASE-T Operation

10BASE-T MII Operations

The MAC transmits data to the LXT970 over the MII interface. The LXT970 converts the digital data from the MAC into an analog waveform that is transmitted to the network via the copper interface. The LXT970 converts analog signals received from the network into a digital format suitable for the MAC. The LXT970 sends the received data to the MAC via the MII. The 5-bit symbol code is not used for 10BASE-T operation. The MII operates only as a 4-bit interface and the RXD4 & TXD4 lines are not used.

10BASE-T Network Operations

During 10BASE-T operation, the LXT970 transmits and receives Manchester-encoded data across the network link. When the MAC is not actively transmitting data, the LXT970 sends out link pulses on the line.

In 10BASE-T mode, the polynomial scrambler/descrambler is inactive. Manchester-encoded signals received from the network are decoded by the LXT970 and sent across the MII to the MAC.

The LXT970 does not support fiber connections at 10 Mbps.

Protocol Sublayer Operations

With respect to the 7-layer communications model, the LXT970 is a Physical Layer 1 (PHY) device. The LXT970 implements the Physical Coding Sublayer (PCS), Physical Medium Attachment (PMA), and Physical Medium Dependent (PMD) sublayers of the reference model defined by the IEEE 802.3u specification. The following paragraphs discuss LXT970 operation from the reference model point of view.

PCS Sublayer

The Physical Coding Sublayer (PCS) provides the MII interface, as well as the 4B/5B encoding/decoding function when the MII is operating as a 4B interface.

For 100TX and 100FX operation, the PCS layer provides IDLE symbols to the PMD-layer line driver as long as TX_EN is de-asserted.

When the MII is operating in 5B mode, the encoder/decoder function is disabled, and symbol data presented at the MII is transparently passed downstream, and vice versa.

For 10T operation, the PCS layer merely provides a bus interface and serialization/de-serialization function. 10T operation does not use the 4B/5B encoder, and is not supported when the MII is in 5B mode.

100X Preamble Handling

When the MAC asserts TX_EN, the PCS substitutes a /J/K symbol pair, also known as the Start of Stream Delimiter or SSD, for the first two nibbles received across the MII. The PCS layer continues to encode the remaining MII data, following Table 17, until TX_EN is de-asserted. It then returns to supplying IDLE symbols to the line driver.

In the receive direction, the PCS layer performs the opposite function, substituting two preamble nibbles for the SSD.

10T Preamble Handling

In 10BASE-T Mode, the LXT970 strips the entire preamble off of received packets. CRS is asserted a few bit times after carrier is detected. RX_DV is not asserted for the duration of the preamble.

When RX_DV is asserted, the very first two nibbles driven by the LXT970 are the SFD “5D” hex followed by the body of the packet. In 10T loopback the LXT970 loops back whatever the MAC transmits to it, including the preamble.

Figure 14: LXT970 Protocol Sublayers

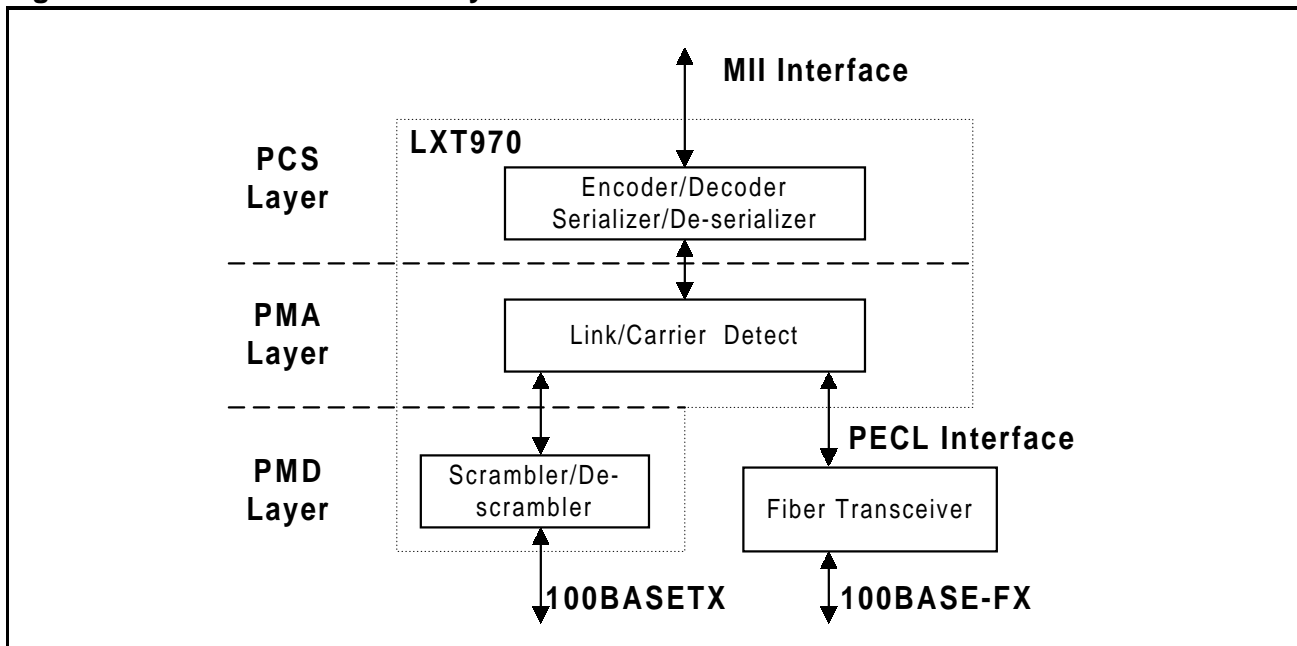

Data Errors (100X Only)

Figure 15 shows normal reception. When the LXT970 receives invalid symbols from the line, it asserts RX_ER, as shown in Figure 16.

Collision Indication

Figure 17 shows normal transmission. The LXT970 detects a collision if transmit and receive are active at the same time. As shown in Figure 18 upon detection of a collision, the COL output is asserted and remains asserted for the duration of the collision.

Figure 15: 100BASE-TX Reception with No Errors

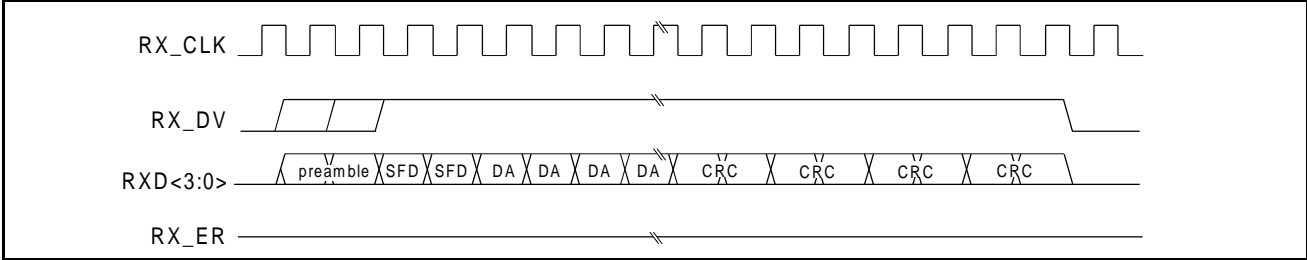

Figure 16: 100BASE-TX Reception with Invalid Symbol

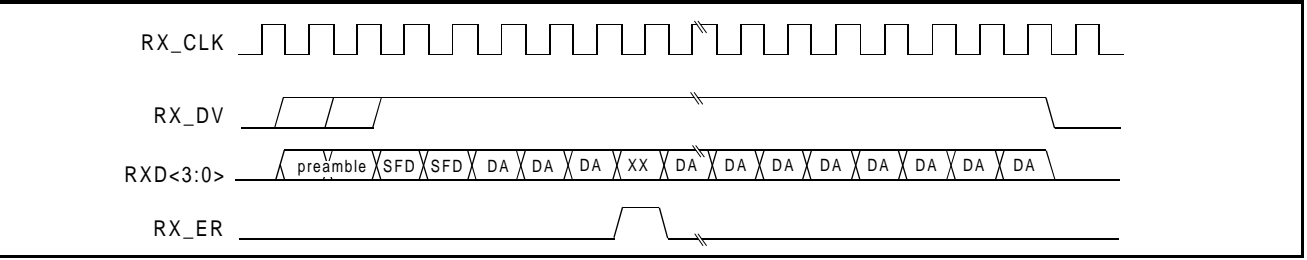

Figure 17: 100BASE-TX Transmission with No Errors

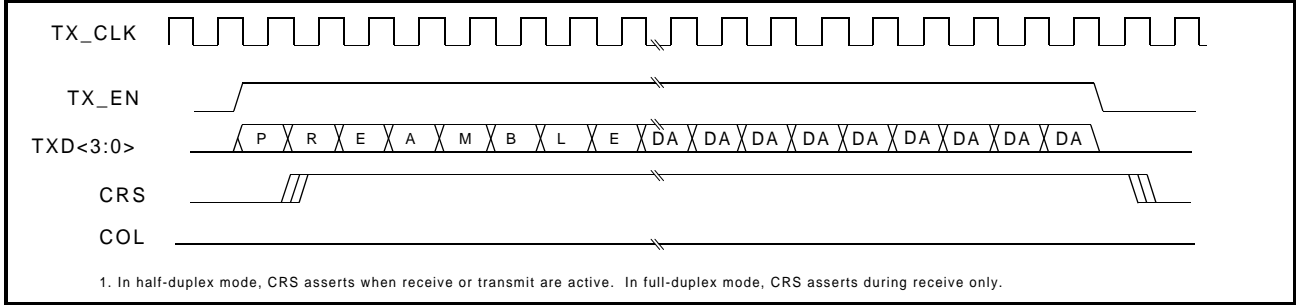
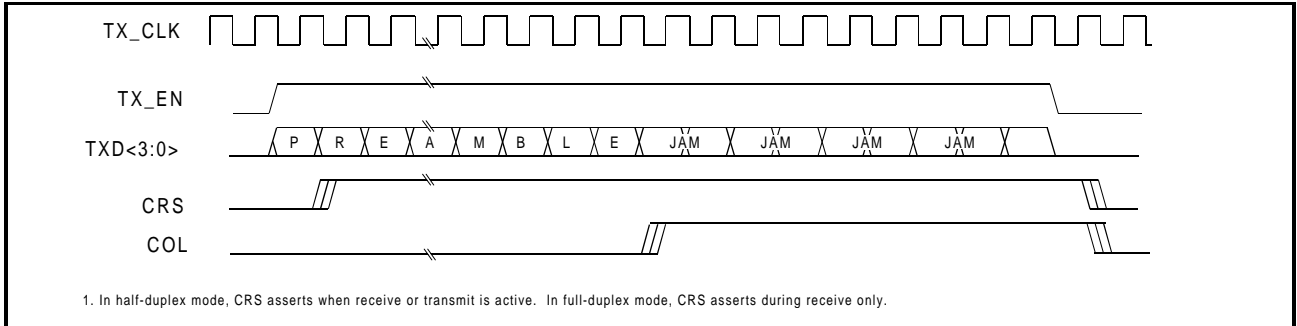

Figure 18: 100BASE-TX Transmission with Collision



SQE (10T Only)

When the SQE (heartbeat) function is enabled, the LXT970 will assert its COL output for 5-15 BT after each packet. By default, the SQE function is disabled on the LXT970. To enable SQE, set bit 19.10 = 1. See Figure 29 on page 52 for SQE timing parameters.

Jabber (10T Only)

If the MAC transmission exceeds the jabber timer, the LXT970 disables the transmit and loopback functions and asserts the COL pin. The LXT970 automatically exits jabber mode after 250-750 ms. This function can be disabled by setting bit 19.9 = 1. See Figure 30 on page 52 for Jabber timing parameters.

Carrier Sense (CRS)

For 100TX and 100FX links, a start-of-stream delimiter or /J/K symbol pair causes assertion of carrier sense (CRS). An end-of-stream delimiter, or /T/R symbol pair causes de-assertion of CRS. The PMA layer will also de-assert CRS if IDLE symbols are received without /T/R, however in this case RX_ER will be asserted for one clock cycle when CRS is de-asserted.

For 10T links, CRS assertion is based on reception of valid preamble, and de-assertion on reception of an End-of-Frame (EOF) marker.

The PMA layer in the LXT970 does not support the optional far-end-fault function.

PMA Layer

The Physical Medium Attachment (PMA) layer provides link and carrier status functions.

Link

100TX Link Options

The PMA layer follows IEEE standards for establishing, maintaining and breaking down a link.

For 100TX and 100FX applications, the PMA layer will take down the link if the Bit Error Rate (BER) exceeds allowable standards. If the link goes down and auto-negotiation is enabled, the device automatically restarts the auto-negotiation process. Otherwise the device continues to monitor the line for a valid link.

10T Link Test

For 10T operation, link is detected via Normal Link Pulses (NLPs). In 10T mode, the LXT970 always transmits link pulses. If the link test function is enabled, it monitors the connection for link pulses. Once it detects 2 to 7 link pulses, data transmission will be enabled and will remain enabled as long as the link pulses or data transmission continues. Link failure occurs if link test is enabled and link pulses stop being received. If this condition occurs, the LXT970 returns to the auto-negotiation phase if auto-negotiation is enabled.

If the link test function is disabled, the LXT970 will transmit to the connection regardless of detected link pulses. The link test function can be disabled by setting bit 19.8 = 1 or by setting MF0 to disable auto-negotiation and setting CFG1 input High.

Twisted-Pair PMD Layer

The twisted-pair Physical Medium Dependent (PMD) layer provides the signal scrambling and descrambling, line coding and decoding (MLT-3 for 100TX, Manchester for 10T), as well as receiving, polarity correction, and baseline wander correction functions.

Scrambler/Descrambler (100TX Only)

The purpose of the scrambler is to spread the signal power spectrum and reduce EMI and baseline wander. Scrambling is done with an 11-bit, non-data-dependent polynomial. The receiver automatically decodes the polynomial whenever IDLE symbols are received.

The LXT970 provides a scrambler-bypass mode for testing purposes. Bypassing the scrambler causes the PCS-layer encoder to be bypassed as well, and the MII to operate in 5B mode.

Baseline Wander Correction (100TX Only)

The LXT970 provides a baseline wander correction function which makes the device robust under all network operating conditions. The MLT3 coding scheme used in 100BASE-TX is by definition “unbalanced”. This means that the average DC value of the signal voltage can “wander” significantly over short time intervals (tenths of seconds). In less robust devices, this wander can cause receiver errors, particularly at long line lengths (100 meters). The exact characteristics of the wander are completely data dependent. The LXT970 baseline wander correction circuitry allows error-free data recovery, even at long line lengths.

Polarity Correction

The LXT970 automatically detects and corrects for the condition where the receive signal (TPIP/N) is inverted. Reversed polarity is detected if eight inverted link pulses, or four inverted end-of-frame markers, are received consecutively. If link pulses or data are not received for 96-128 ms, the polarity state is reset to a non-inverted state.

Fiber PMD Layer

The LXT970 provides a pseudo-ECL interface for connection to an external fiber optic transceiver. The external transceiver provides the PMD function for fiber media. The LXT970 uses an NRZI format for the fiber interface. The fiber interface operates at 100 Mbps and is intended for 100FX applications. It does not support 10FL applications. The fiber interface does not support the signal detect function supplied by most fiber optic transceivers. However, the link detection function in the PMA layer will quickly detect faults in the fiber link.

Additional Operating Features

Low-Voltage Fault Detect

The LXT970 low-voltage fault detection function prevents transmission of invalid symbols when VCC goes below normal operating levels. If this condition occurs, the LXT970 disables the transmit outputs and sets $20.2 = 1$. Operation is automatically restored when VCC returns to normal. Table 27 on page 41 indicates voltage levels used to detect and clear the low-voltage fault condition.

Power-Down Mode

The LXT970 goes into power-down mode when PWRDWN is asserted. In this mode, all functions are disabled except the MDIO. The power supply current is significantly reduced. This mode can be used for energy-efficient applications or for redundant applications where there are two devices and one is left as a stand-by. When the LXT970 is returned to normal operation, configuration settings of the MDIO registers are maintained. Refer to Table 23 on page 39 for power-down specifications and Table 44 on page 55 for hardware reset specifications.

Software Reset

Software reset causes all state machines to be reset and the LXT970 to re-configure itself to the settings of the hardware configuration pins (MF<4:0>, FDE, CFG0, CFG1).

The LXT970 may be reset via software by setting bit $0.15 = 1$. This bit setting will be maintained while the reset operation is running. When the reset operation is complete, the LXT70 will reset bit $0.15 = 0$.

Hardware Reset

Hardware reset causes the LXT970 to reset all of its functions and re-configure itself based on the hardware configuration pin settings.

The LXT970 will perform a hardware reset when a Low signal is detected at the RESET pin. All operational conditions must be met for this function to operate. VCC must be above 4.75V and stable, and the RESET signal must be asserted for two cycles of the master input clock. The LXT970 continues to drive an internal reset for a period of 300 μ s after the RESET signal is de-asserted to ensure that all functions start up smoothly. MII registers are not available and the MDIO output is tri-stated during the internal reset period. Refer to Table 44 on page 55 for hardware reset specifications.

APPLICATION INFORMATION

Magnetics Information

The LXT970 requires a 1:1 ratio for both the receive and the transmit transformers. Refer to Table 18 for magnetics requirements.

Table 19 provides a cross-reference list of compatible magnetics components from various vendors. This information is provided only as a reference. Designers must test and evaluate all components for suitability in their applications.

Table 18: Magnetics Requirements

Parameter	Min	Nom	Max	Units	Test Condition
Rx and Tx Turns Ratio	–	1:1	–	–	
Insertion Loss	0.0	–	1.1	dB	
Primary Inductance	350	–	–	μH	
Transformer Isolation	–	2	–	kV	
Differential to common mode rejection	–	–	-40	dB	.1 to 60 MHz
	–	–	-35	dB	60 to 100 MHz
Return Loss	–	–	-17	dB	.1 to 60 MHz
	–	–	-15	dB	60 to 100 MHz
Rise Time	2.0	–	3.5	ns	10% to 90%

Table 19: Magnetics Component Manufacturers

Manufacturer	Single Port	Dual Port	Quad Port
Belfuse	S558-5999-39	S558-5999-75	S558-5999-C0
HALO	TG22-3506ND TD22-3506G1 TG22-S010ND TG22-S012ND TG110-S050N2	TG110-3506NX TG110-S025NX	TG110-6506NX TG110-S450NS
Nanopulse	6120-30 6120-37 6170-30 6181-37	6809-30 6815-30	6887-30 6923-30 6886-30 6931-30
Pulse (Fil-Mag)	PE-68517L PE-68515L H1019 H1012	H1026 H1028	H1036L H1044
Valor	ST6118 ST6114	ST6155	ST6160 ST6163

Crystal Information

The LXT970 requires a parallel-resonant fundamental-mode crystal that meet specifications as shown in Table 20. XI and XO input capacitance and voltage requirements are provided in Table 26 on page 41.

Crystals are available from various manufacturers. Designers should test and validate all crystals before committing to a specific component. Based on limited evaluation, Table 21 lists some suitable crystal manufacturers and part numbers.

Table 20: Crystal Requirements

Parameter	Min	Nom	Max	Units	Test Condition
Frequency	–	25.0	–	MHz	
Frequency Stability	–	–	±100	ppm	-40 - 85°C
1. See Table 26 (Clock Characteristics) for additional device specifications.					

Table 21: Crystal Component Manufacturers

Component	Manufacturer	Part Number
Crystal	Epson America	MA-505-25.000M
	Caliber Electronics	AA18C1-25.000MHz

Design Recommendations

The LXT970 is designed in accordance with IEEE requirements and provides outstanding receive Bit Error Ratio (BER) and long-line-length performance. Lab tests show that the LXT970 performs well beyond the required distance of 100 meters. Ensuring maximum performance from the LXT970 requires attention to detail and good design practices. Refer to the *LXT970 Design and Layout Guide* for detailed design and layout information.

General Design Guidelines

Adherence to generally accepted design practices is essential to minimize noise levels on power and ground planes. Up to 50 mV of noise is considered acceptable. 50 to 80 mV of noise is considered marginal. High-frequency switching noise can be reduced, and its effects can be eliminated, by following these simple guidelines throughout the design:

- Fill in unused areas of the signal planes with solid copper and attach them with vias to a VCC or ground plane that is not located adjacent to the signal layer.
- Use ample bulk and decoupling capacitors throughout the design (a value of .01 μ F is recommended for decoupling caps).
- Provide ample power and ground planes.
- Provide termination on all high-speed switching signals and clock lines.
- Provide impedance matching on long traces to prevent reflections.
- Route high-speed signals next to a continuous, unbroken ground plane.
- Filter and shield DC-DC converters, oscillators, etc.
- Do not route any digital signals between the LXT970 and the RJ45 connectors at the edge of the board.
- Do not extend any circuit power and ground plane past the center of the magnetics or to the edge of the board. Use this area for chassis ground, or leave it void.

Power Supply Filtering

Power supply ripple and digital switching noise on the VCC plane can cause EMI problems and degrade line performance. It is generally difficult to predict in advance the performance of any design, although certain factors greatly increase the risk of having these problems:

- Poorly-regulated or over-burdened power supplies.
- Wide data busses (>32-bits) running at a high clock rate.
- DC-to-DC converters.

Many of these issues can be improved just by following good general design guidelines. In addition, Level One also recommends filtering between the power supply and the analog VCC pins of the LXT970. Filtering has two benefits. First, it keeps digital switching noise out of the analog circuitry inside the LXT970, which helps line performance. Second, if the VCC planes are laid out correctly, it keeps digital switching noise away from external connectors, reducing EMI problems.

The recommended implementation is to divide the VCC plane into two sections. The digital section supplies power to the digital VCC pin, VCC IO pin, and to the external components. The analog section supplies power to VCCA, VCCT, and VCCR pins of the LXT970. The break between the two planes should run under the device. In designs with more than one LXT970, a single continuous analog VCC plane can be used to supply them all.

The digital and analog VCC planes should be joined at one or more points by ferrite beads. The beads should produce at least a 100 Ω impedance at 100 MHz. The beads should be placed so that current flow is evenly distributed. The maximum current rating of the beads should be at least 150% of the current that is actually expected to flow through them. (>400 mA per LXT970). A 10 μ F bulk cap should be placed on each side of each ferrite bead to stop switching noise from traveling through the ferrite.

In addition, a high-frequency bypass cap (.01 μ f) should be placed near each analog VCC pin.

Ground Noise

The best approach to minimize ground noise is strict use of good general design guidelines and by filtering the VCC plane.

Power and Ground Plane Layout Considerations

Great care needs to be taken when laying out the power and ground planes. The following guidelines are recommended:

- Follow the guidelines in the *LXT970 Design and Layout Guide* for locating the split between the digital and analog VCC planes.
- Keep the digital VCC plane away from the TPOP/N and TPIP/N signals, away from the magnetics, and away from the RJ45 connectors.
- Place the layers so that the TPOP/N and TPIP/N signals can be routed near or next to the ground plane. It is more important to shield TPOP/N than TPIP/N for EMI performance.

The Twisted-Pair Interface

Figure 20 on page 38 shows the recommended termination circuits for the twisted-pair interface. This interface consists of magnetics (1:1 ratio) and a 100 Ω termination resistance in parallel on the device-side of the winding. On the transmit pair, a common-mode bypass capacitor to ground is strongly recommended. A similar technique on the receive side can improve performance in some cases, however the results are highly application specific and must be verified. A “Bob Smith” termination is often provided for the unused signal pairs.

The following guidelines apply to when laying out any differential pair:

- Space both members close together, allowing nothing to come between them.
- Keep distances as short as possible, both traces should have the same length.
- Avoid layer changes as much as possible.
- Keep termination circuits close together and on the same side of the board.
- Always put termination circuits close to the source end of any circuit.
- Route TREF nearby, but not in-between TPOP and TPON.

The Fiber Interface

The fiber interface consists of a pseudo-ECL transmit and receive pair to an external fiber optic transceiver. The transmit pair should be AC-coupled to the transceiver, and biased to 3.7V with a 50 Ω equivalent impedance. The receive pair can be DC-coupled, and should be biased to 3.0V with a 50 Ω equivalent impedance. Figure 20 on page 38 shows the correct bias networks to achieve these requirements.

Transmit Hold Time Adjustment

Transmit hold time for TXD, TX_EN, and TX_ER from TX_CLK High is currently specified in Tables 33, 35, 37, and 39 as 5 ns minimum. 0 ns minimum is the IEEE specification. Depending on the specification of the MAC or ASIC used in your design, you may or may not need to account for this in your PC board design.

If you determine that a timing adjustment is required, there are a couple of recommended ways to do this.

- If using series resistors in the TXD lines, increase the value of the resistors to achieve the necessary delay.
- An alternative method is to add the appropriate delay in the TX_CLK line. Depending on the amount of delay required, this may be accomplished with a series resistor or by adding a buffer to the TX_CLK line.

Note that some delay is introduced by the actual PC board traces themselves.

Other Recommendations

- Series termination resistors are strongly advised on the MII signals driven by the LXT970. The correct value to use is the nominal trace impedance minus 13 Ω ; if the trace impedance is not known, use 55 Ω .
- Provide a bulk capacitor (4.7 - 10 μ F) for VCCIO.
- Place the RBIAS resistor as close to the RBIAS pin as possible. Run an etch directly from the pin to the resistor, and sink the other side of the resistor to a filtered ground. Surround the RBIAS trace with a filtered ground; do not run high-speed signals next to RBIAS.

Typical Application

Figure 20 is typical interface circuitry of the LXT970. The diagram groups similar pins; it does not portray the actual chip pinout. The Media Independent Interface pins are at the upper left. Hardware Control Interface pins are center left. The line interface pins for twisted-pair and fiber are shown on the top and bottom right respectively.

The VCCD and VCCIO pins are at the bottom of the diagram. VCCT, VCCR and VCCA are at the center right. All VCC pins (except VCCIO) use a single power supply. VCCIO may be powered by a 3.3V supply, and may be separately connected.

Voltage Divider For MF Inputs

The LXT970 requires an external voltage divider to provide optional (VMF2 and VMF3) multi-level inputs to the Multi-Function (MF) pins. These voltage levels are designated as VMF1 - VMF4. A single voltage divider may be used to drive the MF pins in designs using multiple PHYs. Figure 19 shows a voltage divider with three 1 k Ω resistors configured in series between VCC and Ground.

Figure 19: Voltage Divider

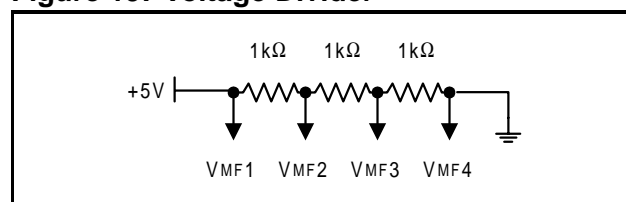
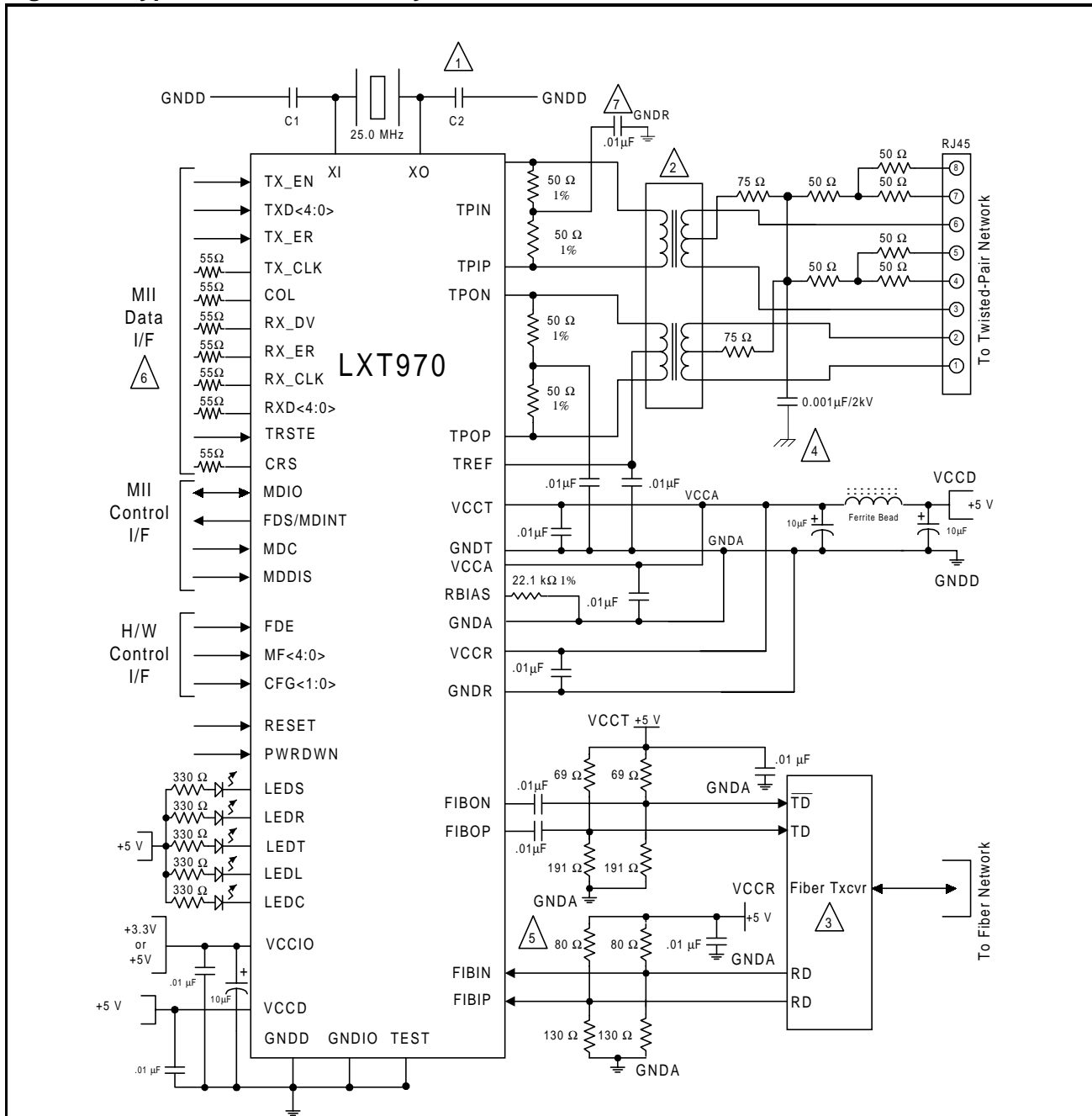

Figure 20: Typical Interface Circuitry



1. Refer to Tables 20 and 21 for crystals.
2. Refer to Tables 18 and 19 for magnetics.
3. Refer to fiber transceiver manufacturer recommendations for termination circuitry. Suitable fiber transceivers include: HFBR-5103 and HBRF-5
4. Bypassing to chassis ground (if available) provides additional EMI shielding.
5. If the fiber interface is not used, FIBIN, FIBIP, FIBON, and FIBOP may be left unconnected.
6. Series terminations resistors are recommended for all MII outputs. The proper value is application specific.
7. Placement of this cap should be verified for each application. This cap typically reduces error rates at long-line lengths, but is implementation specific.

TEST SPECIFICATIONS

NOTE

Minimum and maximum values in Tables 22 through 44 and Figures 21 through 35 represent the performance specifications of the LXT970 and are guaranteed by test except, where noted, by design.

Table 22: Absolute Maximum Ratings

Parameter		Sym	Min	Max	Units
Supply Voltage		VCC	-0.3	6	V
Operating Temperature	Ambient	TOPA	-15	+85	°C
	Case	TOPC	–	+120	°C
Storage Temperature		TST	-65	+150	°C
CAUTION					
Exceeding these values may cause permanent damage. Functional operation under these conditions is not implied. Exposure to maximum rating conditions for extended periods may affect device reliability.					

Table 23: Operating Conditions

Parameter		Sym	Min	Typ ¹	Max	Units
Recommended Supply Voltage ²	Except MII Supply	VCC	4.75	5.0	5.25	V
	II Supply	VCCIO	3.125	–	5.25	V
Recommended Operating Temperature	Ambient	TOPA	0	–	70	°C
	Case	TOPC	0	–	110	°C
Power Consumption (+5V Only)	100BASE-TX	ICC	–	170	–	mA
	100BASE-FX	ICC	–	80	–	mA
	10BASE-T	ICC	–	185	–	mA
	Power-Down Mode	ICC	–	9	–	mA
	Auto-Negotiation	ICC	–	240	270	mA
<p>1. Typical values are at 25 °C and are for design aid only; not guaranteed and not subject to production testing.</p> <p>2. Voltages with respect to ground unless otherwise specified.</p>						

Table 24: Digital I/O Characteristics¹ - (Over Recommended Range)

Parameter	Symbol	Min	Typ ²	Max	Units	Test Conditions
Input Low Voltage ³	V _{IL}	–	–	.8	V	
Input High Voltage ³	V _{IH}	2.0	–	–	V	
Input Current	I _I	-10	–	10	μA	0.0 < V _I < V _{CC}
Output Low Voltage	V _{OL}	–	–	0.4	V	I _{OL} = 4 mA
Output High Voltage - (MII only)	V _{OH}	2.2	–	–	V	I _{OH} = -4 mA, V _{CCIO} = 3.3V
Output High Voltage	V _{OH}	2.4	–	–	V	I _{OH} = -4 mA, V _{CCIO} = 5.0V
Driver Output Resistance (Line Driver Output Enabled)	R _O ¹	6.0	–	25.0	Ω	V _{CCIO} = 3.3V
	R _O ¹	6.0	–	25.0	Ω	V _{CCIO} = 5.0V

1. Applies to all pins except MF<4:0> pins. Refer to Table 25 for MF pin I/O Characteristics.
 2. Typical values are at 25 °C and are for design aid only; not guaranteed and not subject to production testing.
 3. Does not apply to X1 or TX_CLK pins. Refer to Table 26 for clock input levels.

Table 25: Digital I/O Characteristics - MultiFunction Pins MF<4:0> (Over Recommended Range)

Parameter	Symbol	Min	Typ ¹	Max	Units	Test Conditions
Input Voltage Level 1	V _{MF1}	V _{CC} - 0.5	–	–	V	
Input Voltage Level 2	V _{MF2}	(V _{CC} /2) + 0.5	–	V _{CC} - 1.2	V	
Input Voltage Level 3	V _{MF3}	1.2	–	V _{CC} /2 - 0.5	V	
Input Voltage Level 4	V _{MF4}	–	–	0.5	V	

1. Typical values are at 25 °C and are for design aid only; not guaranteed and not subject to production testing.

Table 26: Required Clock Characteristics

Parameter	Sym	Min	Typ ¹	Max	Units	Test Conditions
Master Clock Mode - External XI Clock Input						
Input Low Voltage ²	V _{IL}	–	–	1.0	V	
Input High Voltage ²	V _{IH}	3.2	–	–	V	
Input Clock Frequency Tolerance ²	Δf	–	–	± 100	ppm	Clock frequency is 25 MHz or 2.5 MHz
Input Clock Duty Cycle ²	T _{DC}	40	–	60	%	
Input Capacitance (XI and XO)	C _{IN}	–	3.0	–	pF	
Slave Clock Mode - External TX_CLK Input						
Input Low Voltage	V _{IL}	–	–	.8	V	
Input High Voltage	V _{IH}	2.0	–	–	V	
Input Clock Frequency Tolerance ²	Δf	–	–	± 100	ppm	Clock frequency is 25 MHz or 2.5 MHz
Input Clock Duty Cycle ²	T _{DC}	35	–	65	%	
1. Typical values are at 25 °C and are for design aid only; not guaranteed and not subject to production testing. 2. Parameter is guaranteed by design; not subject to production testing.						

Table 27: Low-Voltage Fault Detect Characteristics

Parameter	Sym	Min	Typ ¹	Max	Units	Test Conditions
Detect Fault Threshold	V _{LT}	3.4	–	4.0	V	–
Clear Fault Threshold	V _{LH}	4.1	–	4.7	V	–
1. Typical values are at 25 °C and are for design aid only; not guaranteed and not subject to production testing.						

Table 28: 100BASE-TX Transceiver Characteristics (Over Recommended Range)

Parameter	Sym	Min	Typ ¹	Max	Units	Test Conditions
Peak Differential Output Voltage	VOP	0.95	–	1.05	V	Note 2
Signal Amplitude Symmetry	V _{SS}	98	–	102	%	Note 2
Signal Rise/Fall Time	TRF	3.0	–	5.0	ns	Note 2
Rise/Fall Time Symmetry	TRFS	–	–	0.5	ns	Note 2
Duty Cycle Distortion	DCD	–	–	± 0.5	ns	Offset from 16ns pulse width at 50% of pulse peak
Overshoot/Undershoot	VOS	–	–	5	%	–

1. Typical values are at 25 °C and are for design aid only; not guaranteed and not subject to production testing.
 2. Measured at the line side of the specified transformer, line replaced by 100Ω (±1%) resistor.

Table 29: 100BASE-FX Transceiver Characteristics (Over Recommended Range)

Parameter	Sym	Min	Typ ¹	Max	Units	Test Conditions
Transmitter						
Peak Differential Output Voltage (Single Ended)	VOP	0.6	–	1.0	V	–
Signal Rise/Fall Time	TRF	–	–	1.6	ns	10 <-> 90% 2.0 pF load
Jitter (Measured Differentially)	–	–	–	1.3	ns	–
Receiver						
Peak Differential Input Voltage	VIP	0.55	–	1.5	V	–
Common-Mode Input Range	VCMIR	2.25	–	VCC - 0.5	V	–

1. Typical values are at 25 °C and are for design aid only; not guaranteed and not subject to production testing.

Table 30: 10BASE-T Transceiver Characteristics (Over Recommended Range)

Parameter	Sym	Min	Typ ¹	Max	Units	Test Conditions
Transmitter						
Peak Differential Output Voltage	VOP	2.2	2.5	2.8	V	With specified transformer, line replaced by 100Ω (±1%) resistor
Transmit Timing Jitter added by the MAU and PLS Sections ^{2,3}	–	0	2	11	ns	After line model specified by IEEE 802.3 for 10BASE-T MAU
Receiver						
Receive Input Impedance ²	ZIN	–	3.6	–	kΩ	Between TPIP/TPIN
Differential Squelch Threshold	VDS	300	420	585	mV	5 MHz square wave input
1. Typical values are at 25 °C and are for design aid only; not guaranteed and not subject to production testing. 2. Parameter is guaranteed by design; not subject to production testing. 3. IEEE 802.3 specifies maximum jitter additions at 1.5 ns for the AUI cable, 0.5 ns from the encoder, and 3.5 ns from the MAU.						

Table 31: 10BASE-T Link Integrity Timing Characteristics (Over Recommended Range)

Parameter	Sym	Min	Typ ¹	Max	Units	Test Conditions
Time Link Loss Receive	TLL	50	64	150	ms	–
Link Pulse	TLP	2	4	7	Link Pulses	–
Link Min Receive Timer	TLR MIN	2	4	7	ms	–
Link Max Receive Timer	TLR MAX	50	64	150	ms	–
Link Transmit Period	TLT	8	10	24	ms	–
Link Pulse Width	TLPW	–	100	–	ns	–
1. Typical values are at 25 °C and are for design aid only; not guaranteed and not subject to production testing.						

Figure 21: MII - 100BASE-TX Receive Timing / 4B Mode

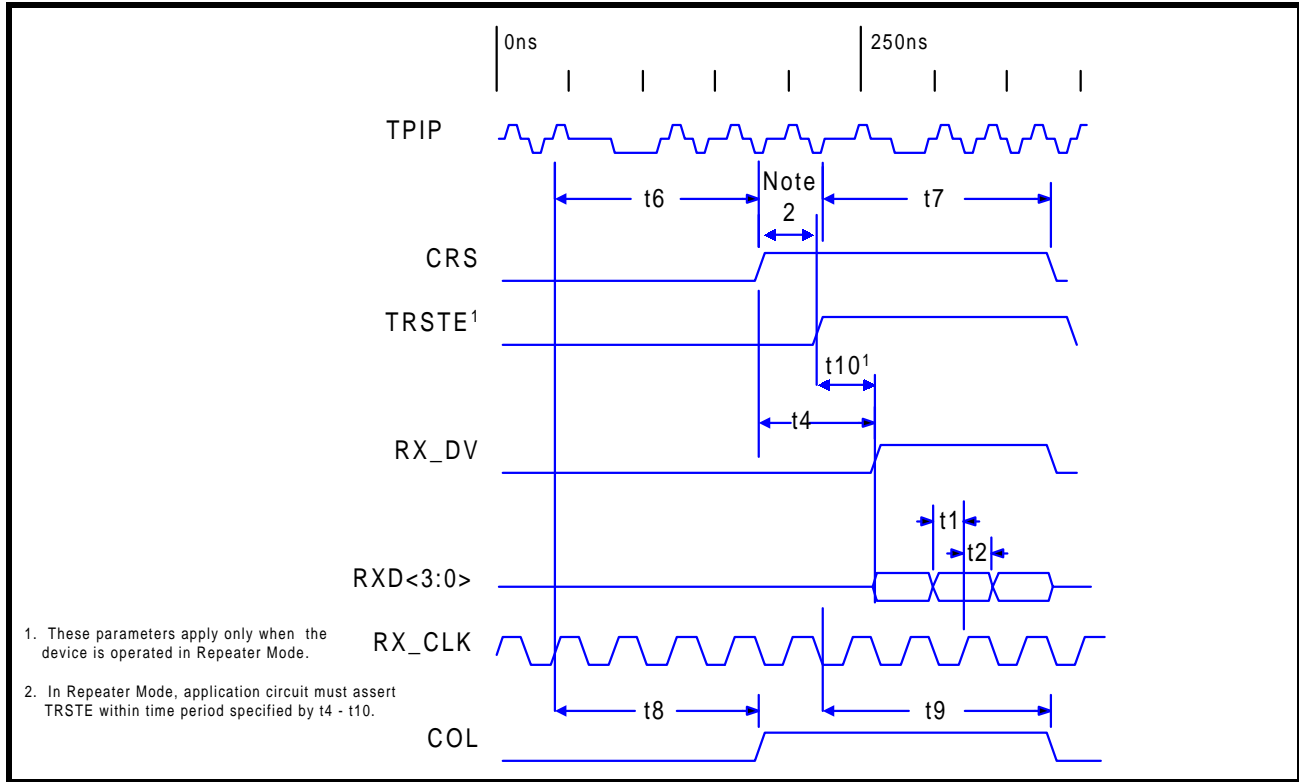

Table 32: MII - 100BASE-TX Receive Timing Parameters / 4B Mode (Over Recommended Range)

Parameter	Sym	Min	Typ ¹	Max	Units ³
RXD, RX_DV, RX_ER Setup to RX_CLK High	t1	10	–	–	ns
RXD, RX_DV, RX_ER Hold from RX_CLK High	t2	10	–	–	ns
CRS asserted to RXD<3:0>, RX_DV asserted	t4	–	8	–	BT
Receive start of “J” to CRS asserted	t6	0	15 - 19	20	BT
Receive start of “T” to CRS de-asserted	t7	13	23 - 27	28	BT
Receive start of “J” to COL asserted	t8	0	15 - 19	20	BT
Receive start of “T” to COL de-asserted	t9	13	23 - 27	28	BT
TRSTE asserted to RX_DV, RXD<3:0> driven ²	t10	–	20	–	ns

1. Typical values are at 25 °C and are for design aid only; not guaranteed and not subject to production testing.
 2. These parameters apply only when the device is operated in Repeater Mode.
 3. BT is the duration of one bit as transferred to and from the MAC and is the reciprocal of the bit rate. 100BASE-T bit time = 10⁻⁸s or 10 ns.

Figure 22: MII - 100BASE-TX Transmit Timing / 4B Mode

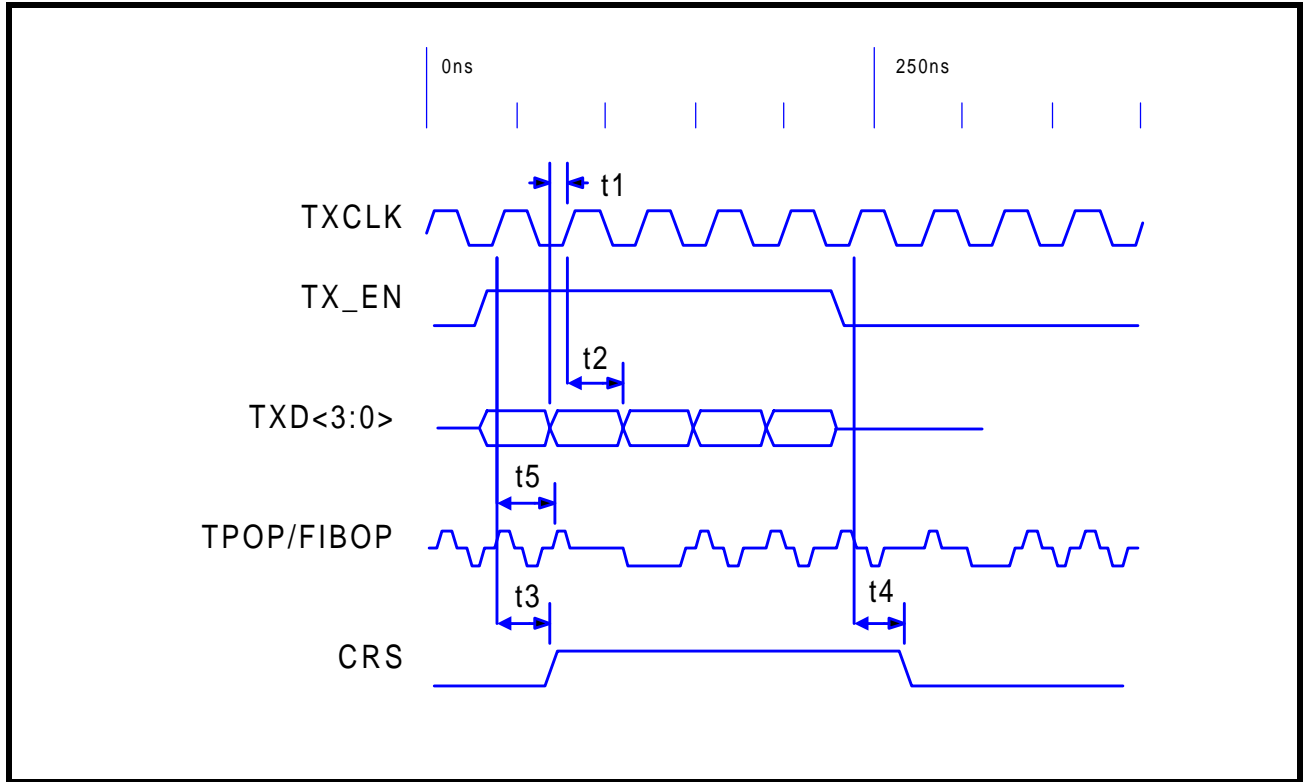

Table 33: MII - 100BASE-TX Transmit Timing Parameters / 4B Mode (Over Recommended Range)

Parameter	Sym	Min	Typ ¹	Max	Units ²
TXD<3:0>, TX_EN, TX_ER Setup to TX_CLK High	t1	10	–	–	ns
TXD<3:0>, TX_EN, TX_ER Hold from TX_CLK High	t2	5	–	–	ns
TX_EN sampled to CRS asserted	t3	–	3	4	BT
TX_EN sampled to CRS de-asserted	t4	–	4	16	BT
TX_EN sampled to TPO out (Tx latency)	t5	6	10	14	BT

1. Typical values are at 25 °C and are for design aid only; not guaranteed and not subject to production testing.
 2. BT is the duration of one bit as transferred to and from the MAC and is the reciprocal of the bit rate. 100BASE-T bit time = 10⁻⁸s or 10 ns.

Figure 23: MII - 100BASE-TX Receive Timing / 5B Mode

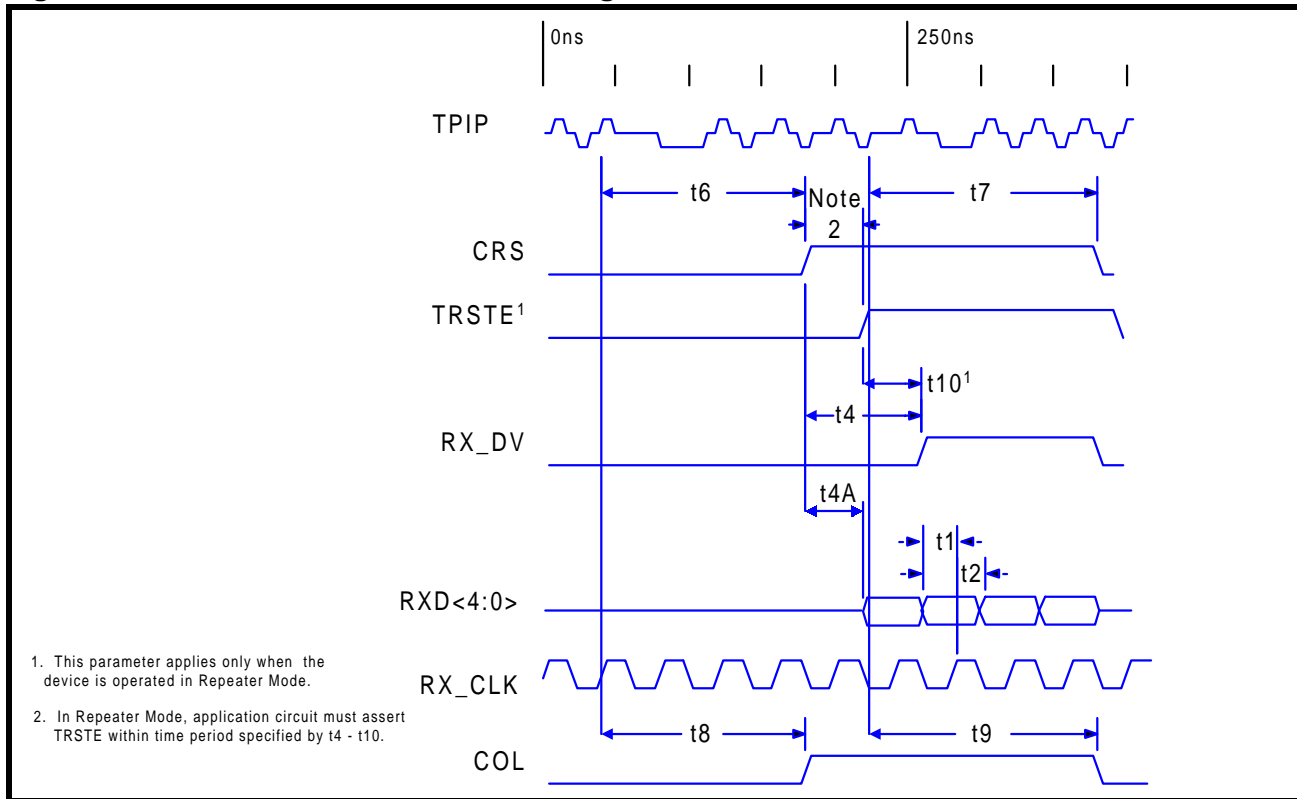

Table 34: MII - 100BASE-TX Receive Timing Parameters / 5B Mode (Over Recommended Range)

Parameter	Sym	Min	Typ ¹	Max	Units ³
RXD, RX_DV, RX_ER Setup to RX_CLK High	t1	10	–	–	ns
RXD, RX_DV, RX_ER Hold from RX_CLK High	t2	10	–	–	ns
CRS asserted to RX_DV asserted	t4	–	8	–	BT
CRS asserted to RXD<4:0> asserted	t4A	–	4	–	BT
Receive start of “J” to CRS asserted	t6	0	15 - 19	20	BT
Receive start of “T” to CRS de-asserted	t7	13	23 - 27	28	BT
Receive start of “J” to COL asserted	t8	0	15 - 19	20	BT
Receive start of “T” to COL de-asserted	t9	13	23 - 27	28	BT
TRSTE asserted to RX_DV, RXD<4:0> driven ²	t10	–	20	–	ns

1. Typical values are at 25 °C and are for design aid only; not guaranteed and not subject to production testing.
 2. These parameters apply only when the device is operated in Repeater Mode.
 3. BT is the duration of one bit as transferred to and from the MAC and is the reciprocal of the bit rate. 100BASE-T bit time = 10⁻⁸s or 10 ns.

Figure 24: MII - 100BASE-TX Transmit Timing / 5B Mode

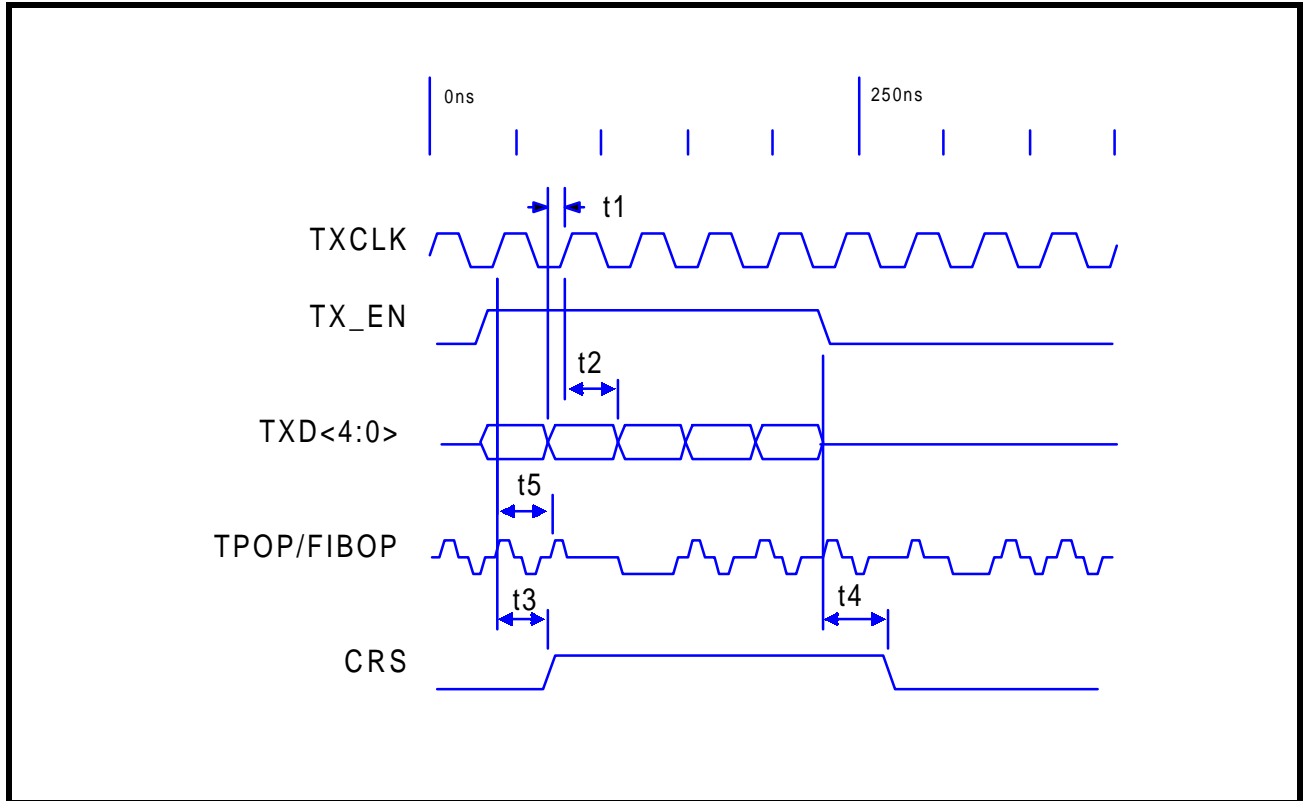

Table 35: MII - 100BASE-TX Transmit Timing Parameters / 5B Mode (Over Recommended Range)

Parameter	Sym	Min	Typ ¹	Max	Units ²
TXD, TX_EN, TX_ER Setup to TX_CLK High	t1	10	–	–	ns
TXD, TX_EN, TX_ER Hold from TX_CLK High	t2	5	–	–	ns
TX_EN sampled to CRS asserted	t3	–	3	4	BT
TX_EN sampled to CRS de-asserted	t4	–	4	16	BT
TX_EN sampled to TPO out (Tx latency)	t5	4	6	9	BT

1. Typical values are at 25 °C and are for design aid only; not guaranteed and not subject to production testing.
 2. BT is the duration of one bit as transferred to and from the MAC and is the reciprocal of the bit rate. 100BASE-T bit time = 10^{-8} s or 10 ns.

Figure 25: MII - 100BASE-FX Receive Timing / 4B Mode

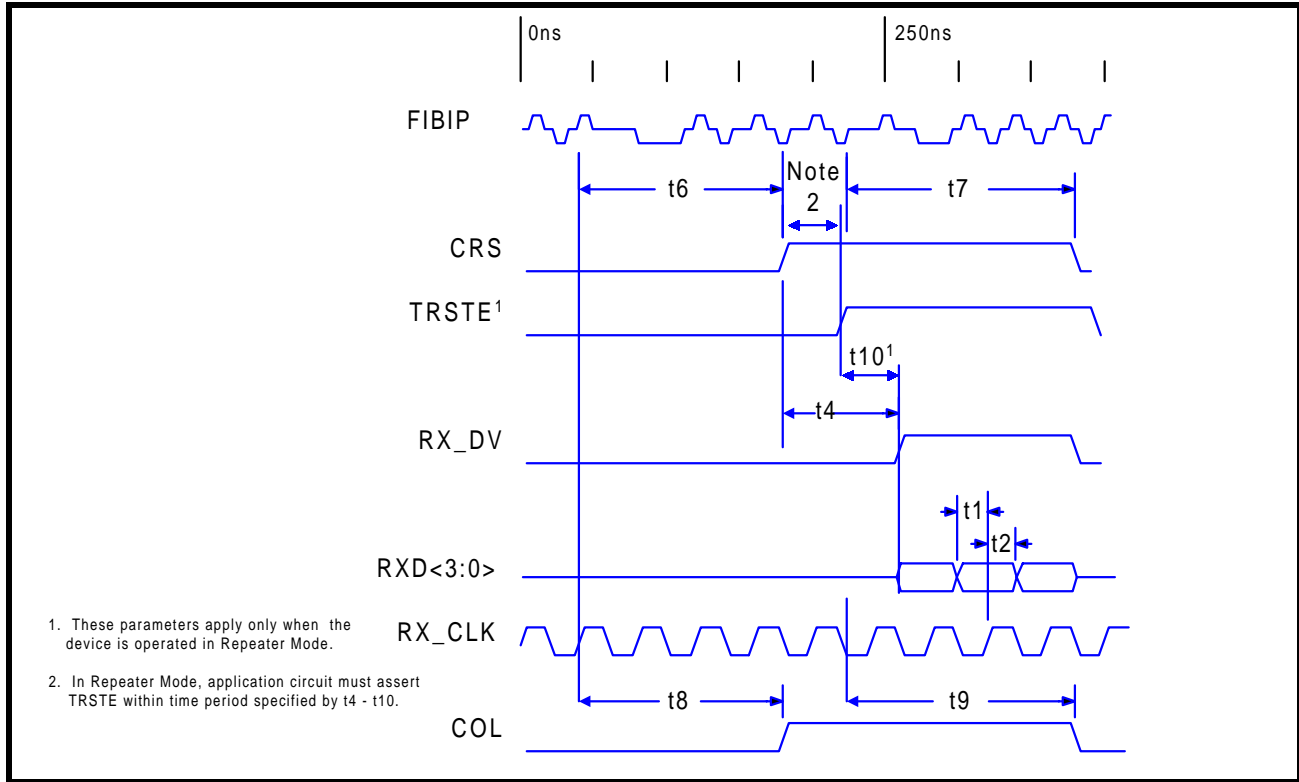

Table 36: MII - 100BASE-FX Receive Timing Parameters / 4B Mode (Over Recommended Range)

Parameter	Sym	Min	Typ ¹	Max	Units ³
RXD, RX_DV, RX_ER Setup to RX_CLK High	t1	10	–	–	ns
RXD, RX_DV, RX_ER Hold from RX_CLK High	t2	10	–	–	ns
CRS asserted to RXD<3:0>, RX_DV asserted	t4	–	8	–	BT
Receive start of “J” to CRS asserted	t6	0	13 - 17	20	BT
Receive start of “T” to CRS de-asserted	t7	13	21 - 25	26	BT
Receive start of “J” to COL asserted	t8	0	13 - 17	20	BT
Receive start of “T” to COL de-asserted	t9	13	21 - 25	26	BT
TRSTE asserted to RX_DV, RXD<3:0> driven ²	t10	–	20	–	ns

1. Typical values are at 25 °C and are for design aid only; not guaranteed and not subject to production testing.
 2. These parameters apply only when the device is operated in Repeater Mode.
 3. BT is the duration of one bit as transferred to and from the MAC and is the reciprocal of the bit rate. 100BASE-T bit time = 10⁻⁸s or 10 ns.

Figure 26: MII - 100BASE-FX Transmit Timing / 4B Mode

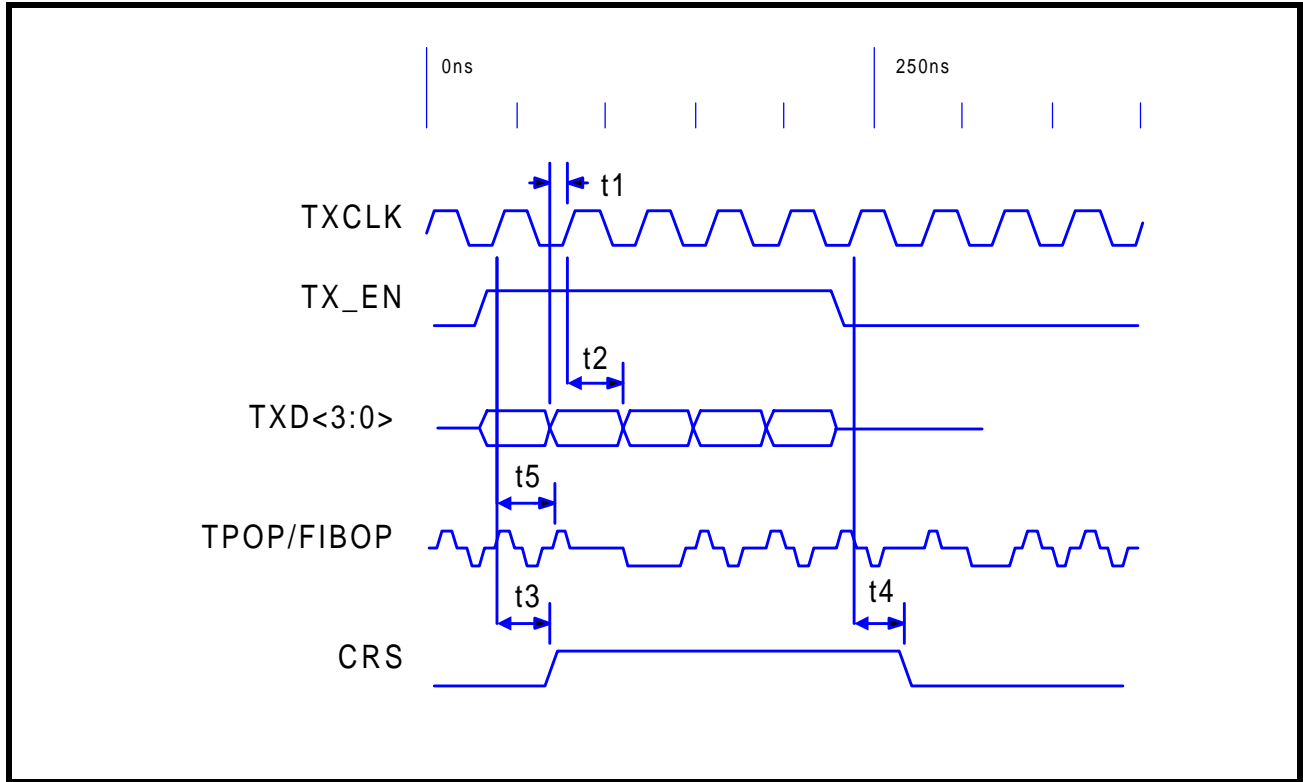

Table 37: MII - 100BASE-FX Transmit Timing Parameters / 4B Mode (Over Recommended Range)

Parameter	Sym	Min	Typ ¹	Max	Units ²
TXD<3:0>, TX_EN, TX_ER Setup to TX_CLK High	t1	10	–	–	ns
TXD<3:0>, TX_EN, TX_ER Hold from TX_CLK High	t2	5	–	–	ns
TX_EN sampled to CRS asserted	t3	–	3	4	BT
TX_EN sampled to CRS de-asserted	t4	–	4	16	BT
TX_EN sampled to TPO out (Tx latency)	t5	6	11	14	BT

1. Typical values are at 25 °C and are for design aid only; not guaranteed and not subject to production testing.
 2. BT is the duration of one bit as transferred to and from the MAC and is the reciprocal of the bit rate. 100BASE-T bit time = 10⁻⁸s or 10 ns.

Figure 27: MII - 10BASE-T Receive Timing

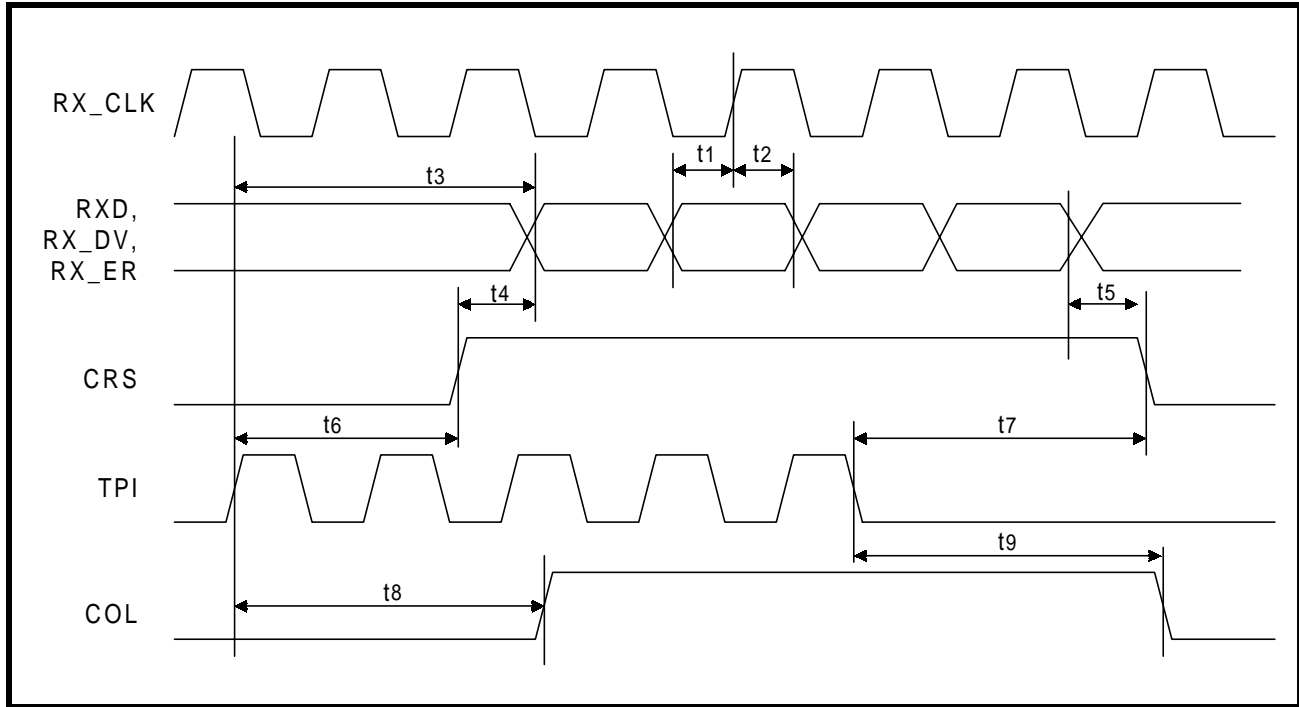

Table 38: MII - 10BASE-T Receive Timing Parameters (Over Recommended Range)

Parameter	Sym	Min	Typ ¹	Max	Units ⁴
RXD, RX_DV, RX_ER Setup to RX_CLK High	t1	10	–	–	ns
RXD, RX_DV, RX_ER Hold from RX_CLK High	t2	10	–	–	ns
TPI in to RXD out (Rx latency)	t3	–	–	73 ³	BT ²
CRS asserted to RXD, RX_DV, RX_ER asserted	t4	0	–	69 ³	BT
RXD, RX_DV, RX_ER de-asserted to CRS de-asserted	t5	0	2.5 - 5.5	6	BT
TPI in to CRS asserted	t6	0	4	5	BT
TPI quiet to CRS de-asserted	t7	0	18	19	BT
TPI in to COL asserted	t8	0	4	5	BT
TPI quiet to COL de-asserted	t9	0	18	19	BT

1. Typical values are at 25 °C and are for design aid only; not guaranteed and not subject to production testing.
 2. IEEE 802.3 defines BT as “the duration of one bit as transferred to and from the MAC. The bit time is the reciprocal of the bit rate. For example, for 10BASE-T the bit time is 10⁻⁷ or 100 ns.”
 3. CRS is asserted. RXD/RX_DV are driven at the start of SFD (64 BT).
 4. BT is the duration of one bit as transferred to and from the MAC and is the reciprocal of the bit rate. 10BASE-T bit time = 10⁻⁷s or 100 ns.

Figure 28: MII - 10BASE-T Transmit Timing

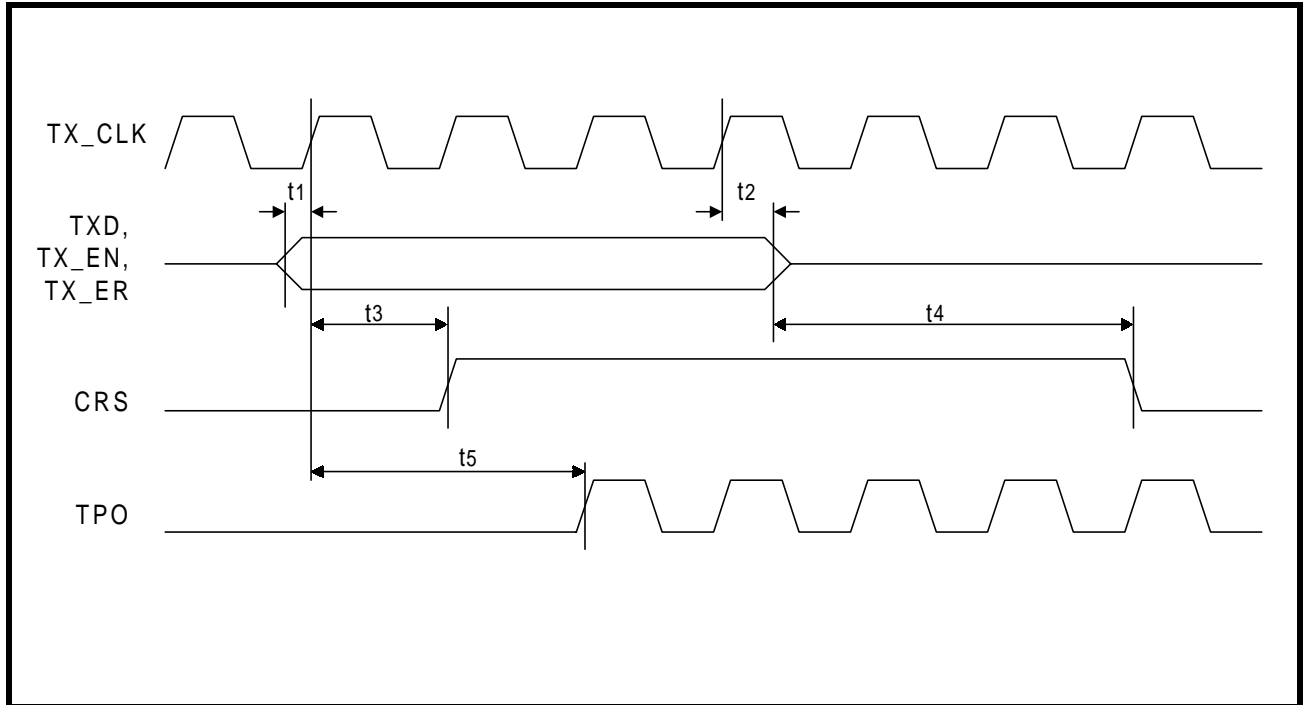

Table 39: MII - 10BASE-T Transmit Timing Parameters (Over Recommended Range)

Parameter	Sym	Min	Typ ¹	Max	Units ²
TXD, TX_EN, TX_ER Setup to TX_CLK High	t1	10	–	–	ns
TXD, TX_EN, TX_ER Hold from TX_CLK High	t2	5	–	–	ns
TX_EN sampled to CRS asserted	t3	–	0	4	BT
TX_EN sampled to CRS de-asserted	t4	–	8	–	BT
TX_EN sampled to TPO out (Tx latency)	t5	–	3 - 5	–	BT

1. Typical values are at 25 °C and are for design aid only; not guaranteed and not subject to production testing.
 2. BT is the duration of one bit as transferred to and from the MAC and is the reciprocal of the bit rate. 10BASE-T bit time = 10⁻⁷s or 100 ns.

Figure 29: 10BASE-T SQE (Heartbeat) Timing

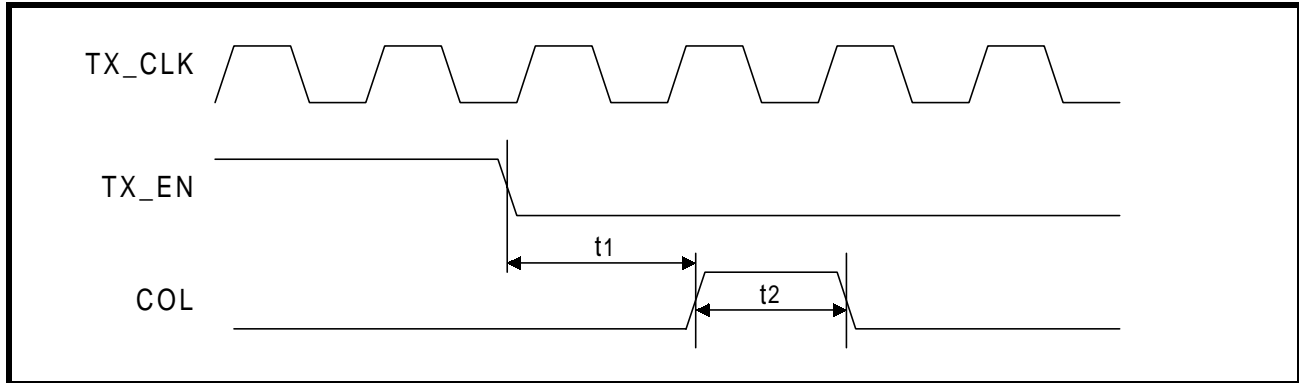

Table 40: 10BASE-T SQE (Heartbeat) Timing Parameters (Over Recommended Range)

Parameter	Sym	Min	Typ ¹	Max	Units
COL (SQE) Delay after TX_EN off	t1	0.65	1.0	1.6	μs
COL (SQE) Pulse duration	t2	.5	1.0	1.5	μs

1. Typical values are at 25 °C and are for design aid only; not guaranteed and not subject to production testing.

Figure 30: 10BASE-T Jab and Unjab Timing

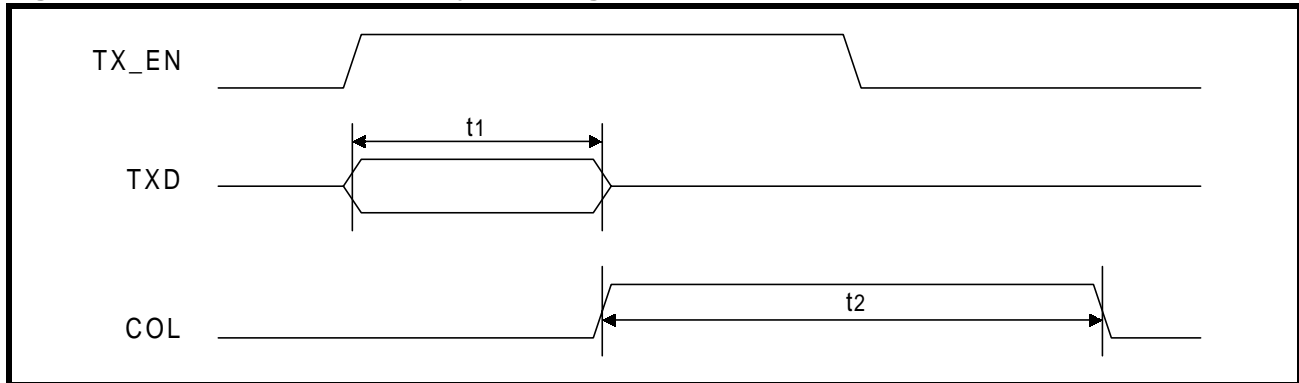

Table 41: 10BASE-T Jab and Unjab Timing Parameters (Over Recommended Range)

Parameter	Sym	Min	Typ ¹	Max	Units
Maximum Transmit time	t1	20	96 - 128 ²	150	ms
Unjab time	t2	250	525	750	ms

1. Typical values are at 25 °C and are for design aid only; not guaranteed and not subject to production testing.
 2. Typical transmit time may be either of these values depending on internal 32 ms clock synchronization.

Figure 31: Auto Negotiation and Fast Link Pulse Timing

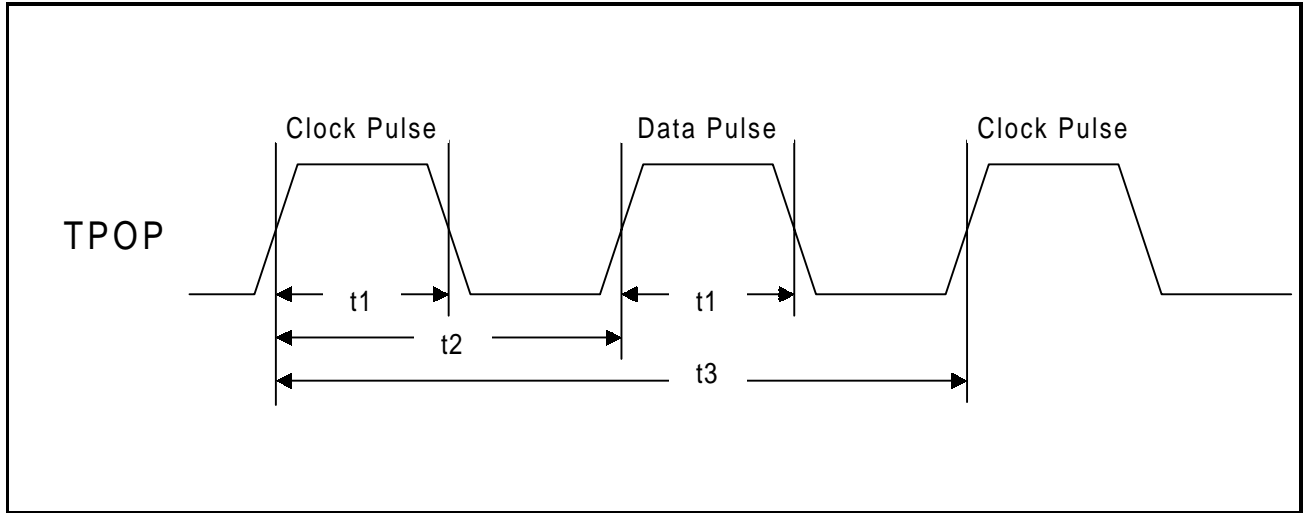

Figure 32: Fast Link Pulse Timing

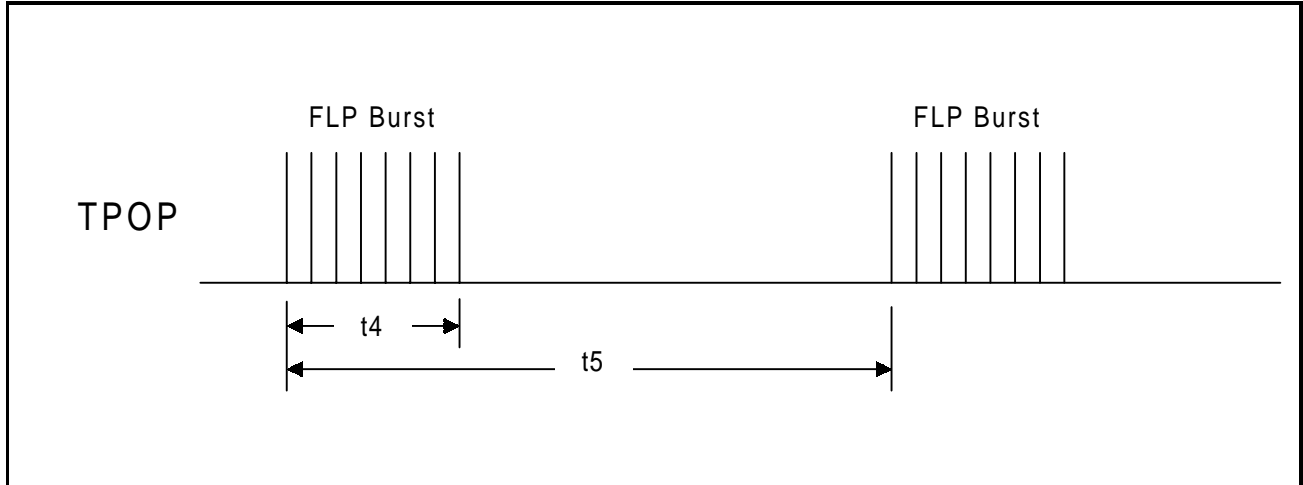

Table 42: Auto Negotiation and Fast Link Pulse Timing Parameters (Over Recommended Range)

Parameter	Sym	Min	Typ ¹	Max	Units
Clock/Data pulse width	t1	–	100	–	ns
Clock pulse to Data pulse	t2	55.5	62.5	69.5	μs
Clock pulse to Clock pulse	t3	111	125	139	μs
FLP burst width	t4	–	2	–	ms
FLP burst to FLP burst	t5	8	12	24	ms
Clock/Data pulses per burst	–	17	–	33	ea

1. Typical values are at 25 °C and are for design aid only; not guaranteed and not subject to production testing.

Figure 33: MDIO Timing when Sourced by STA

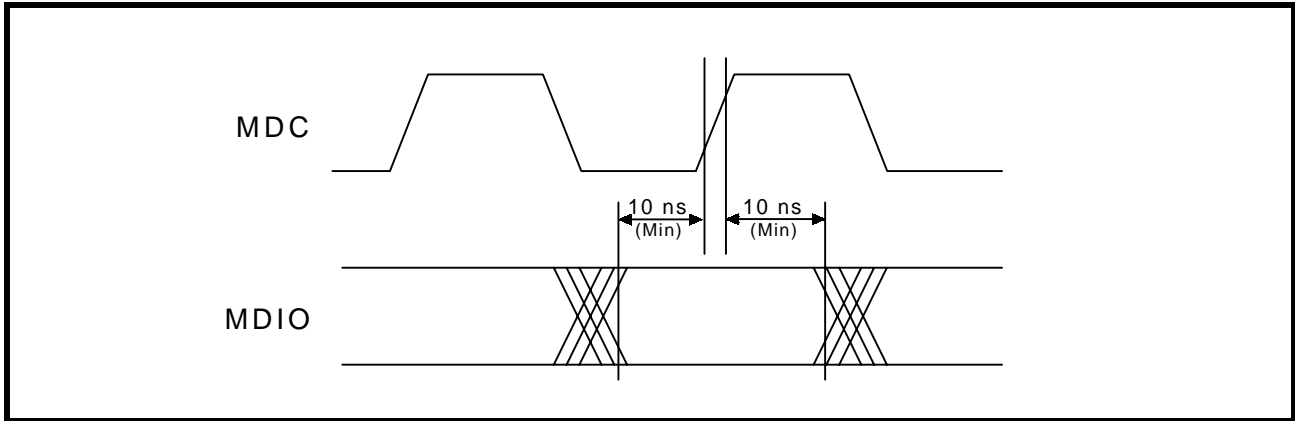

Figure 34: MDIO Timing when Sourced by PHY

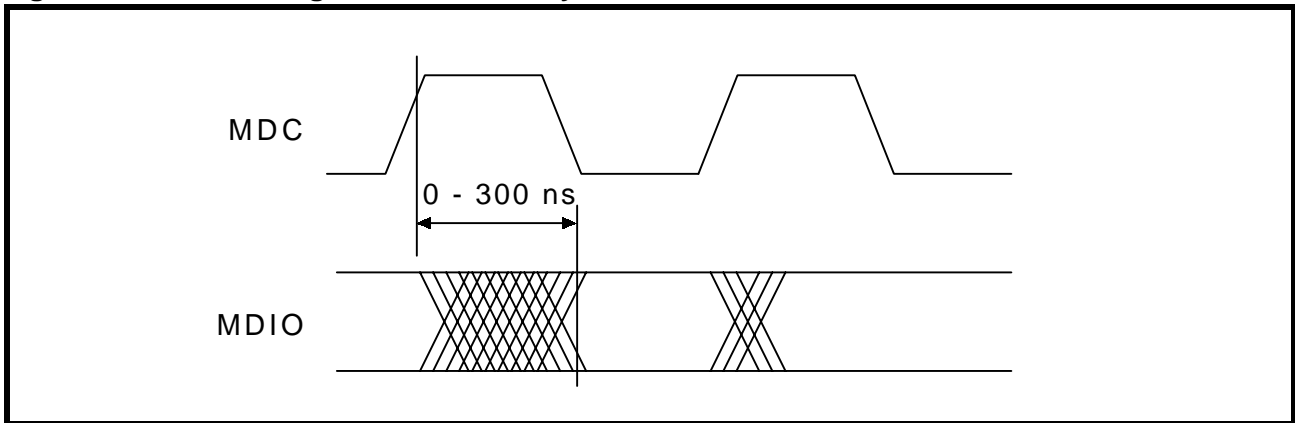

Table 43: MDIO Timing Parameters (Over Recommended Range)

Parameter	Sym	Min	Typ ¹	Max	Units	Test Conditions
MDIO Setup before MDC	–	10	–	–	ns	When sourced by STA
MDIO Hold after MDC	–	10	–	–	ns	When sourced by STA
MDC to MDIO Output delay	–	0	10	300	ns	When sourced by PHY

1. Typical values are at 25° C and are for design aid only; not guaranteed and not subject to production testing.

Figure 35: Power-Down/Hardware Reset Timing Parameters (Over Recommended Range)

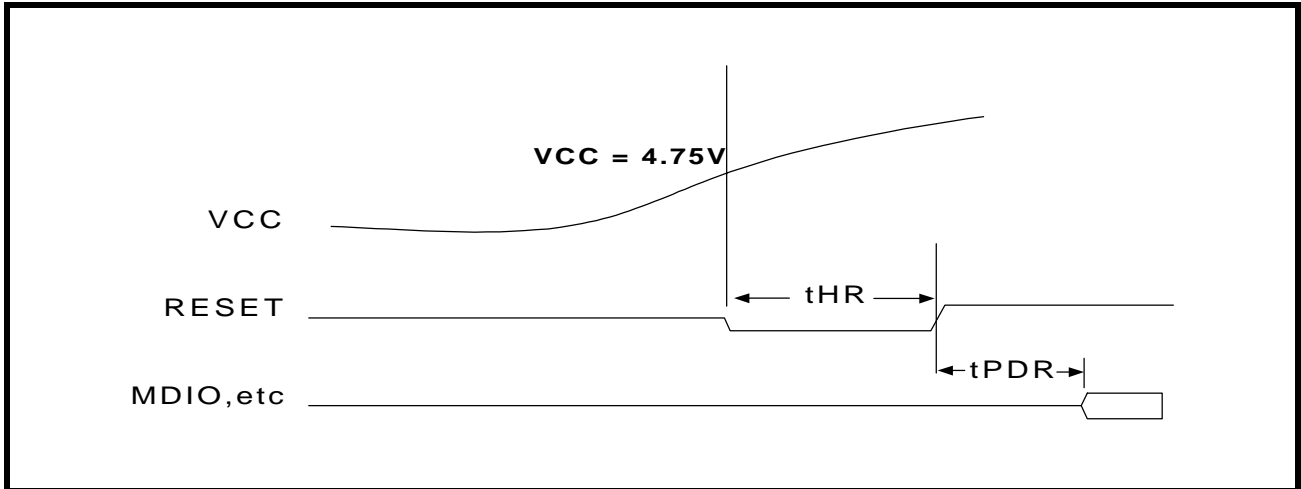

Table 44: Power-Down Recovery/Hardware Reset Timing Parameters

Parameter	Sym	Min	Typ ¹	Max	Units	Test Conditions
Power-Down recovery time	tPDR	–	50	–	ms	Revision B8 and earlier
Power-Down recovery time	tPDR	–	1.0	–	ms	Revision B9 only
Hardware reset time	tHR	–	300	–	μs	All Revisions

1. Typical values are at 25° C and are for design aid only; not guaranteed and not subject to production testing.

REGISTER DEFINITIONS

The LXT970 register set includes a total of twelve 16-bit registers. Refer to Table 45 for a complete register listing.

- Seven base registers (0 through 6) are defined in accordance with the “Reconciliation Sublayer and Media Independent Interface” and “Physical Layer Link Signaling for 10/100 Mbps Auto-Negotiation” sections of the IEEE 802.3 specification (Register 7, Next Page, is not supported).
- Five additional registers (16 through 20) are defined in accordance with the IEEE 802.3 specification for adding unique chip functions.

Table 45: Register Set

Address	Register Name	Bit Assignments
0	Control Register	Refer to Table 46
1	Status Register	Refer to Table 47
2	PHY Identification Register 1	Refer to Table 48
3	PHY Identification Register 2	Refer to Table 49
4	Auto-Negotiation Advertisement Register	Refer to Table 50
5	Auto-Negotiation Link Partner Ability Register	Refer to Table 51
6	Auto-Negotiation Expansion Register	Refer to Table 52
16	Mirror Register	Refer to Table 53
17	Interrupt Enable Register	Refer to Table 54
18	Interrupt Status Register	Refer to Table 55
19	Configuration Register	Refer to Table 56
20	Chip Status Register	Refer to Table 57

Table 46: Control Register (Address 0)

Bit	Name	Description	Type ¹	Default
0.15	Reset	1 = Reset chip. 0 = Enable normal operation.	R/W SC	0
0.14	Loopback	1 = Enable loopback mode. When Loopback is enabled, during 100 Mbps operation, the LXT970 disconnects its transmitter and receiver from the network. Data sent by the controller passes through the chip and then gets looped back to the MII. During 10 Mbps operation the preamble, SFD, and data loop directly back to the MII. 0 = Disable loopback mode.	R/W	0
0.13	Speed Selection	1 = 100 Mbps 0 = 10 Mbps	R/W	Note 2
0.12	Auto-Negotiation Enable	1 = Enable auto-negotiate process (overrides speed select and duplex mode bits). 0 = Disable auto-negotiate process.	R/W	Note 3
0.11	Power-Down	1 = Enable power-down. 0 = Enable normal operation.	R/W	Note 4
0.10	Isolate	1 = Electrically isolate LXT970 from MII. 0 = Normal operation.	R/W	Note 5
0.9	Restart Auto-Negotiation	1 = Restart auto-negotiation process. 0 = Normal operation.	R/W SC	Note 6
0.8	Duplex Mode	1 = Enable full-duplex. 0 = Enable half-duplex.	R/W	Note 7
0.7	Collision Test	1 = Enable COL signal test. Bit 0.14 must be enabled to use this bit. This bit is used in conjunction with bit 0.14 to test the COL output. 0 = Disable COL signal test.	R/W	0 Note 8
0.6:4	Transceiver Test Mode	Not Supported	RO	0
0.3	Master-Slave Enable	Not Supported	RO	0
0.2	Master-Slave Value	Not Supported	RO	0
0.1:0	Reserved		R/W	0

1. R/W = Read/Write
SC = Self Clearing

2. If auto-negotiation is enabled, this bit is ignored. If auto-negotiation is disabled, the default value of bit 0.13 is determined by pin CFG0.

3. The default value of bit 0.12 is determined by pin MF0.

4. The LXT970 will maintain all set values of the configuration registers upon exiting power-down mode. A delay of 500 ns minimum is required from the time power-down is cleared until any register can be written.

5. The default value of bit 0.10 is determined by pin TRSTE.

6. If auto-negotiation is enabled, the default value of bit 0.9 is determined by pin CFG0. If auto-negotiation is disabled, the default value of bit 0.9 = 0.

7. If auto-negotiation is enabled, this bit is ignored. If auto-negotiation is disabled, the default value of bit 0.8 is determined by pin FDE.

8. This bit is ignored unless loopback is enabled (0.14 = 1).

Table 47: Status Register (Address 1)

Bit	Name	Description	Type ¹	Default
1.15	100BASE-T4	Not Supported	RO	0
1.14	100BASE-X full-duplex	1 = LXT970 able to perform full-duplex 100BASE-X.	RO	1
1.13	100BASE-X half-duplex	1 = LXT970 able to perform half-duplex 100BASE-X	RO	1
1.12	10 Mb/s full-duplex	1 = LXT970 able to operate at 10 Mb/s in full-duplex mode	RO	1
1.11	10 Mb/s half-duplex	1 = LXT970 able to operate at 10 Mb/s in half-duplex mode	RO	1
1.10	100BASE-T2 full-duplex	Not Supported	RO	0
1.9	100BASE-T2 half-duplex	Not Supported	RO	0
1.8	Reserved	Ignore on read	RO	0
1.7	Master-Slave Configuration Fault	Not Supported	RO	0
1.6	MF Preamble Suppression	0 = LXT970 will not accept management frames with preamble suppressed.	RO	0
1.5	Auto-Neg. Complete	1 = Auto-negotiation process complete. 0 = Auto-negotiation process not complete.	RO	0
1.4	Remote Fault	1 = Remote fault condition detected. 0 = No remote fault condition detected. This bit is set when: <ul style="list-style-type: none"> • Link partner transmits a remote fault condition (bit 5.13 = 1) • Link partner protocol is anything other than CSMA-CD (bits 5.4:0 = <00001>) • Link partner advertises T4 capability only (bits 5.9:5 ¼ <10000>) 	RO/LH	0
1.3	Auto-Neg. Ability	1 = LXT970 is able to perform auto-negotiation.	RO	1
1.2	Link Status	1 = Link is up. 0 = Link is down.	RO/LL	0
1.1	Jabber Detect (10BASE-T Only)	1 = Jabber condition detected. 0 = No jabber condition detected.	RO/LH	0
1.0	Extended Capability	1 = Extended register capabilities.	RO	1

1. RO = Read Only
LL = Latching Low (This bit remains Low until read, and then returns High).
LH = Latching High (This bit remains High until read, and then returns Low).

Table 48: PHY Identification Register 1 (Address 2)

Bit	Name	Description	Type ¹	Default
2.15:0	PHY ID Number	The PHY identifier composed of bits 3 through 18 of the OUI.	RO	7810 hex

1. RO = Read Only

Table 49: PHY Identification Register 2 (Address 3)

Bit	Name	Description	Type ¹	Default
3.15:10	PHY ID number	The PHY identifier composed of bits 19 through 24 of the OUI.	RO	000000 bin
3.9:4	Manufacturer's model number	6 bits containing manufacturer's part number.	RO	000000 bin
3.3:0	Manufacturer's revision number	4 bits containing manufacturer's revision number.	RO	0000 bin

1. RO = Read Only

Figure 36: PHY Identifier Bit Mapping

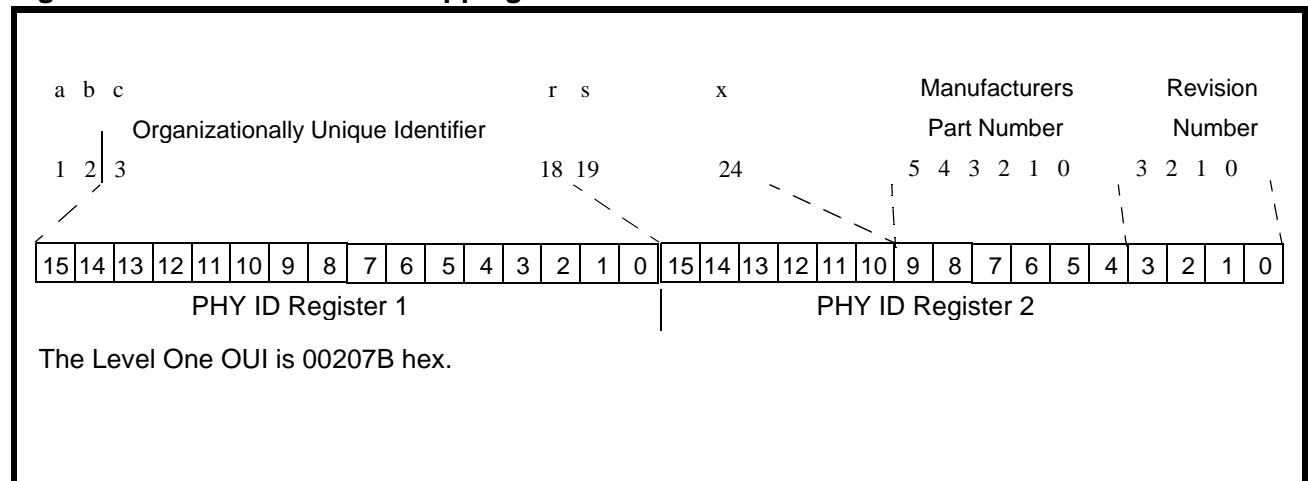

Table 50: Auto Negotiation Advertisement Register (Address 4)

Bit	Name	Description	Type ¹	Default
4.15	Next Page	Not Supported	RO	0
4.14	Reserved	Ignore on read.	RO	0
4.13	Remote Fault	1 = Remote fault. 0 = No remote fault.	R/W	0
4.12:11	Reserved	Ignore on read.	R/W	0
4.10	Pause	1 = Pause operation enabled for full-duplex links. 0 = Pause operation is disabled.	R/W	0
4.9	100BASE-T4	1 = 100BASE-T4 capability is available. 0 = 100BASE-T4 capability is not available. (The LXT970 does not support 100BASE-T4 but allows this bit to be set to advertise in the Auto-Negotiation sequence for 100BASE-T4 operation. An external 100BASE-T4 transceiver could be switched in if this capability is desired.)	R/W	0
4.8	100BASE-TX full-duplex	1 = DTE is 100BASE-TX full-duplex capable. 0 = DTE is not 100BASE-TX full-duplex capable.	R/W	Note 2
4.7	100BASE-TX	1 = DTE is 100BASE-TX capable. 0 = DTE is not 100BASE-TX capable.	R/W	Note 3
4.6	10BASE-T full-duplex	1 = DTE is 10BASE-T full-duplex capable. 0 = DTE is not 10BASE-T full-duplex capable.	R/W	Note 4
4.5	10BASE-T	1 = DTE is 10BASE-T capable. 0 = DTE is not 10BASE-T capable.	R/W	Note 5
4.4:0	Selector Field, S<4:0>	<00001> = IEEE 802.3 <00010> = IEEE 802.9 ISLAN-16T <00000> = Reserved for future Auto-Negotiation development <11111> = Reserved for future Auto-Negotiation development Unspecified or reserved combinations should not be transmitted.	R/W	00001

1. R/W = Read/Write
RO = Read Only
2. The default value of bit 4.8 is determined by pin FDE ANDed with pin MF4.
3. The default value of bit 4.7 is determined by pin MF4.
4. The default value of bit 4.6 is determined by pin FDE AND'ed with pin CFG1.
5. The default value of bit 4.5 is determined by pin CFG1.

Table 51: Auto Negotiation Link Partner Ability Register (Address 5)

Bit	Name	Description	Type ¹	Default
5.15	Next Page	1 = Link Partner has ability to send multiple pages. 0 = Link Partner has no ability to send multiple pages.	RO	N/A
5.14	Acknowledge	1 = Link Partner has received Link Code Word from LXT970. 0 = Link Partner has not received Link Code Word from LXT970.	RO	N/A
5.13	Remote Fault	1 = Remote fault. 0 = No remote fault.	RO	N/A
5.12:11	Reserved	Ignore on read.	RO	N/A
5.10	Pause	1 = Pause operation enabled for link partner. 0 = Pause operation is disabled.	RO	N/A
5.9	100BASE-T4	1 = Link Partner is 100BASE-T4 capable. 0 = Link Partner is not 100BASE-T4 capable.	RO	N/A
5.8	100BASE-TX full-duplex	1 = Link Partner is 100BASE-TX full-duplex capable. 0 = Link Partner is not 100BASE-TX full-duplex capable.	RO	N/A
5.7	100BASE-TX	1 = Link Partner is 100BASE-TX capable. 0 = Link Partner is not 100BASE-TX capable.	RO	N/A
5.6	10BASE-T full-duplex	1 = Link Partner is 10BASE-T full-duplex capable. 0 = Link Partner is not 10BASE-T full-duplex capable.	RO	N/A
5.5	10BASE-T	1 = Link Partner is 10BASE-T capable. 0 = Link Partner is not 10BASE-T capable.	RO	N/A
5.4:0	Selector Field S[4:0]	<00001> = IEEE 802.3 <00010> = IEEE 802.9 ISLAN-16T <00000> = Reserved for future Auto-Negotiation development <11111> = Reserved for future Auto-Negotiation development Unspecified or reserved combinations shall not be transmitted.	RO	N/A

1. RO = Read Only

Table 52: Auto Negotiation Expansion (Address 6)

Bit	Name	Description	Type ¹	Default
6.15:5	Reserved	Ignore.	RO	0
6.4	Parallel Detection Fault	1 = Parallel detection fault has occurred. 0 = Parallel detection fault has not occurred.	RO/ LH	0
6.3	Link Partner Next Page Able	1 = Link partner is next page able. 0 = Link partner is not next page able.	RO	0
6.2	Next Page Able	Not Supported	RO	0
6.1	Page Received	1 = 3 identical and consecutive link code words have been received from link partner. 0 = 3 identical and consecutive link code words have not been received from link partner.	RO/ LH	0
6.0	Link Partner Auto Neg Able	1 = Link partner is auto-negotiation able. 0 = Link partner is not auto-negotiation able.	RO	0

1. RO = Read Only
LH = Latching High (This bit remains High until read, and then returns Low).

Table 53: Mirror Register (Address 16, Hex 10)

Bit	Name	Description	Type ¹	Default
16.15:0	User Defined	This register is intended for use in checking the MII serial port and has no effect on chip operation.	R/W	0

1. R/W = Read /Write

Table 54: Interrupt Enable Register (Address 17, Hex 11)

Bit	Name	Description	Type ¹	Default
17.15:2	Reserved	Write as 0; ignore on read.	R/W	N/A
17.1	INTEN	1 = Enable interrupts. Must be enabled for bit 17.0 or 19.12 to be effective. 0 = Disable interrupts.	R/W	0
17.0	TINT	1 = Forces MDINT Low and sets bit 18.15 = 1. Also forces interrupt pulse on MDIO when bit 19.12 = 1. 0 = Normal operation. This bit is ignored unless the interrupt function is enabled (17.1 = 1).	R/W	0
1. R/W = Read /Write				

Table 55: Interrupt Status Register (Address 18, Hex 12)

Bit	Name	Description	Type ¹	Default
18.15	MINT	1 = Indicates MII interrupt pending. 0 = Indicates no MII interrupt pending. This bit is cleared by reading Register 1 followed by reading Register 18.	RO	N/A
18.14	XTALOK	1 = Indicates that the LXT970 is fully powered up and the on-chip clocks are stable. 0 = Indicates that XTAL circuit is not stable.	RO	0
18.13:0	Reserved	Ignore	RO	0
1. RO = Read Only				

Table 56: Configuration Register (Address 19, Hex 13)

Bit	Name	Description	Type ¹	Default															
19.15	Reserved	Write as 0; ignore on read.	R/W	N/A															
19.14	Txmit Test (100BASE-TX)	1 = 100BASE-T transmit test enabled, LXT970 will transmit data regardless of link status. This function is the analog of the link test function (19.8) for 100BASE-TX. 0 = Normal operation.	R/W	0															
19.13	Repeater Mode	1 = Enable Repeater Mode. 0 = Enable DTE Mode.	R/W	Note 2															
19.12	MDIO_INT	1 = Enable interrupt signaling on MDIO (if 17.1 = 1). 0 = Normal operation (MDIO Interrupt disabled). Bit is ignored unless the interrupt function is enabled (17.1 = 1).	R/W	0															
19.11	TP Loopback (10BASE-T)	1 = Disable 10T TP Loopback. Data transmitted by the MAC will not loopback to the RXD and RX_DV and CRS pins. 0 = Enable 10T TP Loopback - Preamble, SFD, and data (RXD, RX_DV, CRS) are directly looped back to the MII.	R/W	0															
19.10	SQE (10BASE-T)	1 = Enable SQE. 0 = Disable SQE (Default).	R/W	0															
19.9	Jabber (10BASE-T)	1 = Disable jabber. 0 = Normal operation (jabber enabled).	R/W	0															
19.8	Link Test (10BASE-T)	1 = Disable 10BASE-T link integrity test. 0 = Normal operation (10BASE-T link integrity test enabled).	R/W	Note 3															
19.7:6	LEDC Programming bits	Determine condition indicated by LEDC. <table border="1" style="margin-left: 20px;"> <thead> <tr> <th>bit 7</th> <th>bit 6</th> <th>Description</th> </tr> </thead> <tbody> <tr> <td>0</td> <td>0</td> <td>LEDC indicates collision</td> </tr> <tr> <td>0</td> <td>1</td> <td>LEDC is off</td> </tr> <tr> <td>1</td> <td>0</td> <td>LEDC indicates activity.</td> </tr> <tr> <td>1</td> <td>1</td> <td>LEDC is continuously on (for diagnostic use).</td> </tr> </tbody> </table>	bit 7	bit 6	Description	0	0	LEDC indicates collision	0	1	LEDC is off	1	0	LEDC indicates activity.	1	1	LEDC is continuously on (for diagnostic use).	R/W	0,0
bit 7	bit 6	Description																	
0	0	LEDC indicates collision																	
0	1	LEDC is off																	
1	0	LEDC indicates activity.																	
1	1	LEDC is continuously on (for diagnostic use).																	
19.5	Advance TX Clock	1 = TX clock is advanced relative to TXD<4:0> and TX_ER by 1/2 TX_CLK cycle. 0 = Normal operation.	R/W	0															
19.4	5B Symbol/ (100BASE-X only) 4B Nibble	1 = 5-bit Symbol Mode (Bypass encoder/decoder); RXD<4:0> symbol data is not aligned. 0 = 4-bit Nibble Mode (Normal operation).	R/W	Note 4															

1. R/W = Read/Write
2. The default value of bit 19.13 is determined by pin MF1.
3. If auto-negotiation is disabled, the default value of bit 19.8 is determined by pin CFG1. If auto-neg is enabled, the default value of bit 19.8 = 0.
4. The default value of bit 19.4 is determined by pin MF2.
5. The default value of bit 19.3 is determined by pin MF3.
6. If auto-negotiation is disabled, default value of bit 19.2 is determined by pin MF4. If auto-negotiation is enabled, default value of bit 19.2 = 0.

Table 56: Configuration Register (Address 19, Hex 13) – continued

Bit	Name	Description	Type ¹	Default
19.3	Scrambler (100BASE-X only)	1 = Bypass transmit scrambler and receive descrambler. 0 = Normal operation (scrambler and descrambler enabled). In FX mode, the LXT970 <i>automatically</i> bypasses the Scrambler. Selecting Scrambler bypass in FX mode will cause the LXT970 to also bypass the 4B/5B encoder and enable Symbol mode MII operation.	R/W	Note 5
19.2	100BASE-FX	1 = Enable 100BASE fiber interface. 0 = Enable 100BASE twisted-pair interface.	R/W	Note 6
19.1	Reserved	Write as 0; Ignore on read.	R/W	0
19.0	Transmit Disconnect	1 = Disconnect TP transmitter from line. 0 = Normal operation.	R/W	0

1. R/W = Read/Write
2. The default value of bit 19.13 is determined by pin MF1.
3. If auto-negotiation is disabled, the default value of bit 19.8 is determined by pin CFG1. If auto-neg is enabled, the default value of bit 19.8 = 0.
4. The default value of bit 19.4 is determined by pin MF2.
5. The default value of bit 19.3 is determined by pin MF3.
6. If auto-negotiation is disabled, default value of bit 19.2 is determined by pin MF4. If auto-negotiation is enabled, default value of bit 19.2 = 0.

Table 57: Chip Status Register (Address 20, Hex 14)

Bit	Name	Description	Type ¹	Default
20.15:14	Reserved	Ignore on read.	RO	N/A
20.13	Link	1 = Link is up. 0 = Link is down. Link bit 20.13 is a duplicate of bit 1.2, except that it is a dynamic indication, whereas bit 1.2 latches Low.	RO	0
20.12	Duplex Mode	1 = Full-duplex. 0 = Half-duplex.	RO	Note 2
20.11	Speed	1 = 100 Mbps operation. 0 = 10 Mbps operation.	RO	Note 2
20.10	Reserved	Ignore on read.	RO	N/A
20.9	Auto-Negotiation Complete	1 = Auto-negotiation process complete. 0 = Auto-negotiation process not complete. Auto-Negotiation Complete bit 20.9 is a duplicate of bit 1.5.	RO/LH	0
20.8	Page Received	1 = Three identical and consecutive link code words have been received. 0 = Three identical and consecutive link code words have not been received. Page Received bit 20.8 is a duplicate of bit 6.1	RO/LH	0
20:7	Reserved	Ignore on read.	RO	0
20.6	Reserved	Ignore on read.	RO	0
20.5	Reserved	Ignore on read.	RO	N/A
20.4	Reserved	Ignore on read.	RO	N/A
20.3	Reserved	Ignore on read.	RO	N/A
20.2	Low-Voltage	1 = Low-voltage fault on VCC has occurred. 0 = No fault.	RO	N/A
20.1	Reserved	Ignore on read.	RO	N/A
20.0	Reserved	Ignore on read.	RO	N/A

1. RO = Read Only
LH = Latching High (This bit remains High until read, and then returns Low).
2. Bits 20.12 and 20.11 reflect the current operating mode of the LXT970.

MECHANICAL SPECIFICATIONS

Figure 37: 64-Pin PQFP Package Diagram

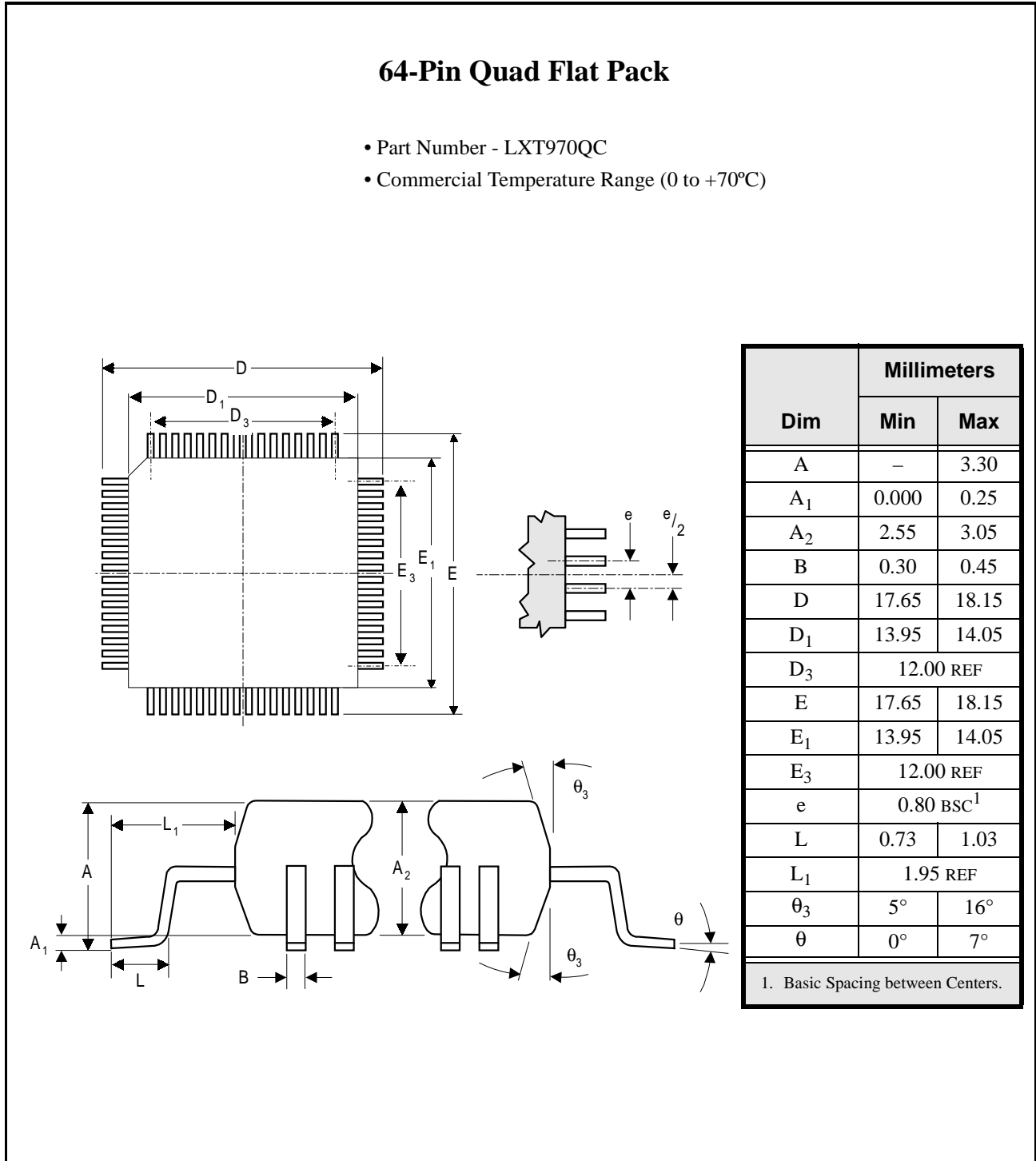

Figure 38: 64-Pin LQFP Package Diagram

64-Pin Low-Profile Quad Flat Pack

- Part Number - LXT970LC
- Commercial Temperature Range (0 to +70°C)

Dim	Millimeters	
	Min	Max
A	–	1.60
A ₁	0.05	0.15
A ₂	1.35	1.45
B	0.30	0.45
D	16.0 BSC ¹	
D ₁	14.0 BSC ¹	
E	16.0 BSC ¹	
E ₁	14.0 BSC ¹	
e	0.80 BSC ¹	
L	0.45	0.75
L ₁	1.00 REF	
θ ₃	11°	13°
θ	0°	7°

1. Basic Spacing between Centers.

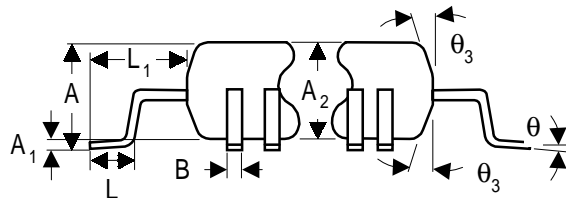
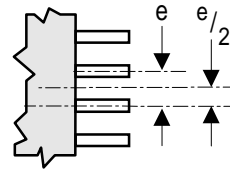
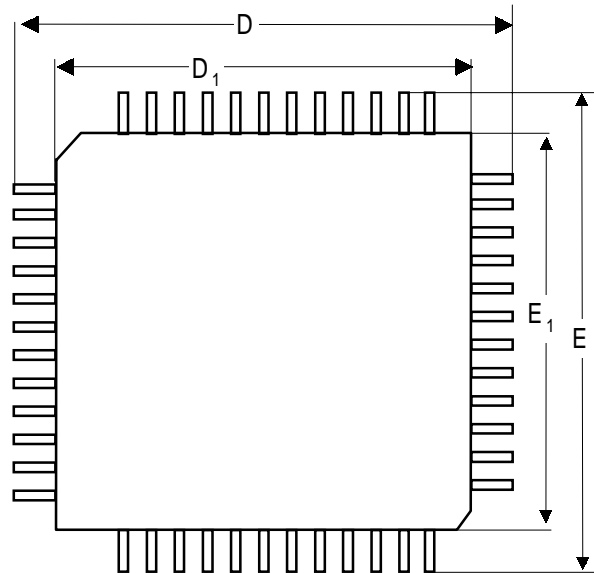

REVISION HISTORY

Table 58: Changes From Revision 1.4 to Revision 1.5 (06/98)

Section	Page #	Change	Text
Features	1	Update	Add “Dual-Speed” to LXT970 product name.
RBIAS	8	Update	Correct external resistor value from 22 k Ω to 22.1 k Ω .
RESET	8	Update	Change reset cycle time from 205 μ s to 300 μ s.
Loopback	16	Update	Rewrite loopback discussion. Add operational and test loopback. Add Table 10 and Figure 5 and re-number subsequent tables and figures.
Additional Operating Features	32	Update	Add hardware and software reset descriptions.
Table 18 Magnetics Req.	33	Update	Change insertion loss Max from .6 to 1.1 dB. Change return loss parameters and differential CMR to negative parameters and move to Max column.
Table 19 Magnetics Components	33	Update	Change Pulse quad-port magnetic H1048 to H1044.
Table 21 Crystal Manufacturers	34	Add	Add crystal manufacturer and part number.
Design Recommendation	35	Update	Rewrite power supply filtering to de-emphasize ground beads.
Figure 20 Typical Circuitry	38	Update	Delete ground ferrite bead and associated note 1. Correct RBIAS resistor value from 22 k Ω to 22.1 k Ω .
Table 24 Digital I/O Characteristics	40	Update	Combine Tables 24 and 26 (now Table 24) and change note 1 to, “Applied to all pins except MF<4:0> pins.” Digital I/O Characteristics for MII pins and all other pins.
10BASE-T Link Timing	43	Update	Move 10BASE-T link timing (was Table 28) to page 43 (now Table 31)
Table 38 10BASE-T Rx Timing	50	Update	Correct Note 3. <i>From:</i> RXD/RX_DV are not driven during preamble and SFD. <i>To:</i> RXD/RX_DV are driven at the start of SFD.
Tables 44 and 45 HW & SW Reset Timing	55	Update	Delete Figure 36 and Table 45, hardware and software timing. Add hardware reset timing to Figure 35 and Table 44. Change HW reset timing from 200 μ s to 300 μ s Typ.
Table 47 Control Register	57	Update	Change note 4 From, “The LXT970 will reset all registers... <i>To:</i> “The LXT970 will maintain all set values of the configuration registers upon exiting power-down mode.”

Table 58: Changes From Revision 1.4 to Revision 1.5 (06/98)

Section	Page #	Change	Text
Table 51 Advertise & Link Partner Registers	60	Update	Add Pause Operation to bit 4.10.
Table 52 Advertise & Link Partner Registers	61	Update	Add Pause Operation to bit 5.10.
Table 55 Interrupt Enable Register	63	Update	Clarify bit 17.1 - Interrupt enable and remove pin 2 reference.
Table 57 Configuration Register	64	Update	Clarify bit 19.11 - TP Loopback.

Table 59: Changes From Revision 1.3 to Revision 1.4 (04/98)

Section	Page #	Change	Text
Features	1	Update	Add 64-pin LQFP package to features list. Add note on bottom of page, referencing WEB.
Figure 1 Pin Assignments	4	Update	Add LQFP package designator. Add associated plane (digital/analog) to power supply signals.
Tables 1 - 7	4 - 9	Update	Add note 1; pin numbers apply to both the QFP and LQFP packages.
Table 18 Magnetics	33	Update	Update Magnetics table - HALO single-port and quad-port part numbers.
Figure 35 Table 45	55	Update	Add hardware and software reset timing figure and parameters.
Figure 34 Table 44	55	Update	Add power-down recovery time for revision B9 parts.
Figure 37 64-pin QFP Diagram	66	Update	Change dimension D ₁ , E ₁ , and L to incorporate JEDEC specs. D ₁ Min from 13.90 to 13.95mm. E ₁ Min from 13.90 to 13.95mm and Max from 14.10 to 14.05mm. L Min from 0.65 to 0.73mm and Max from 0.95 to 1.03mm.
Figure 38 64-pin LQFP Diagram	67	Update	Add 64-pin LQFP package diagram.
Tables 59, 60, 61 Revision History	68	Update	Update revision history.

Table 60: Changes From Revision 1.2 to Revision 1.3 (02/98)

Section	Page #	Change	Text
Table 18 Magnetics	32	Update	Change various magnetics part numbers.
Table 20 Crystals	33	Update	Delete CTS part number CTX093.
Application Info	35	Update	Add transmit hold time adjustment description and workaround.
Figure 19 NIC Application Diagram	36	Update	Delete the beads from VCCR/GNDR and note 2. Change value of bypass caps to .01 μ F.
Tables 21, 22 Absolute Max Recommended Operating	37	Update	Add Operating Case Temperature - 110°C. Absolute Max Case Operating Temperature - 120°C.
Tables 58, 59, 60 Revision History	66	Update	Add revision history tables to back of data sheet.

Table 61: Changes From Revision 1.1 to Revision 1.2 (01/98)

Section	Page #	Change	Text
Table 2 MII Signal Descriptions	5	Update	Add note 3, “The MII outputs of the LXT970 are high-strength drivers....”.
Table 5 LED Signal Descriptions	7	Update	Add note 2, “LED’s are read at power-up to determine scrambler seed values.”
Table 6 Misc Signal Descriptions	7	Correct	Correct reset cycle from 205ns to 205µs.
Table 7 Hardware I/F Signal Descriptions	8	Update	Rewrite multi-function Pin Description for clarification.
Functional Descriptions	12	Update	Rewrite and reorganize Functional section. Add Figures 3 , 4 , 5, and 13. Add Tables 10, 14, and 15.
Table 18 Application Information	32	Update	Add dual-port and quad-port magnetics.
Table 20 Crystals	33	Correct	Correct Epson part # from SE2539CT to MA-505-25.000M.
Design Recommendations	34	Update	Rewrite layout requirements and rename as Design Recommendations.
Figure 19 I/F Circuitry Diagram	36	Change	Change TP inputs on NIC application diagram: Two 50Ω filters instead on one 100Ω Add notes 8 and 9. Change biasing circuit on the fiber input pins from 69Ω and 191Ω to 80Ω and 130Ω Add MII outputs series resistors (55Ω)
Tables 32, 34, 36 Test Specifications	42, 44, 46	Update	Change 100BASE-TX/FX receive hold timing from 5ns to 10ns.
Table 46 Control Register	55	Update	0.14 - Loopback Add: “During 10 Mbps operation the preamble, SFD, and data loop directly back to the MII” to Enable loopback mode.
Table 56 Configuration Register	61	Correct	Correct register description for 19.11 - TP Loopback (10BASE-T). Remove, “CRS is asserted during a transmission only...”, from Disable Loopback. Add, “Preamble is also driven during loopback operation.”, to Enable Loopback.
Table 57 Chip Status Register	63	Change	Change bits 20.0, 20.4, 20.5, 20.6 to reserved.

Table 62: Changes From Revision 1.0 to Revision 1.1 (05/97)

Section	Page #	Change	Text
Table 7 HW I/F Signal Descriptions	8	Update	Minor changes to MF4 pin description.
100 Mbps Operation	21	Update	Add FX Operation Description.
Figure 15 NIC App Diagram	28	Update	Moved TPO bypass caps from VCC to GND.

NOTES

NOTES

Corporate Headquarters

9750 Goethe Road
Sacramento, California 95827
Telephone: (916) 855-5000
Fax: (916) 854-1101
Web: www.level1.com



The Americas

EAST

Eastern Area Headquarters & Northeastern Regional Office

234 Littleton Road, Unit 1A
Westford, MA 01886
Tel: (508) 692-1193
Fax: (508) 692-1244

North Central Regional Office

One Pierce Place
Suite 500E
Itasca, IL 60143
Tel: (630) 250-6044
Fax: (630) 250-6045

Southeastern Regional Office

4020 WestChase Blvd
Raleigh, NC 27607
Tel: (919) 836-9798
Fax: (919) 836-9818

WEST

Western Area Headquarters

3375 Scott Blvd., #110
Santa Clara, CA 95054
Tel: (408) 496-1950
Fax: (408) 496-1955

South Central Regional Office

2340 E. Trinity Mills Road
Suite 306
Carrollton, TX 75006
Tel: (972) 418-2956
Fax: (972) 418-2985

Southwestern Regional Office

28203 Cabot Road
Suite 300
Laguna Niguel, CA 92677
Tel: (714) 365-5655
Fax: (714) 365-5653

Latin/South America

9750 Goethe Road
Sacramento, CA 95827
USA
Tel: (916) 855-5000
Fax: (916) 854-1102

International

ASIA/PACIFIC

Asia / Pacific Area Headquarters

101 Thomson Road
United Square #08-01
Singapore 307591
Tel: +65 353 6722
Fax: +65 353 6711

Central Asia/Pacific Regional Office

Suite 305, 4F-3, No. 75,
Hsin Tai Wu Road
Sec. 1, Hsi-Chih,
Taipei County, Taiwan
Tel: +886 22 698 2525
Fax: +886 22 698 3017

Northern Asia/Pacific Regional Office

Nishi-Shinjuku, Mizuma
Building 8F
3-3-13, Nishi-Shinjuku,
Shinjuku-Ku
Tokyo, 160 Japan
Tel: +81 3 3347-8630
Fax: +81 3 3347-8635

EUROPE

European Area Headquarters

Parc Technopolis - Bat. Zeta
3, avenue du Canada -
Z.A. de Courtaboeuf
91974 Les Ulis Cedex
France
Tel: +33 1 64 86 2828
Fax: +33 1 60 92 0608

Central and Southern Europe Regional Office

“Regus”
Feringastrasse 6
D-85774 Muenchen-
Unterfoerhring, Germany
Tel: +49 89 99 216 375
Fax: +49 89 99 216 377

Northern Europe Regional Office

Torshamnsgatan 35
164/40 Kista/Stockholm,
Sweden
Tel: +46 8 750 3980
Fax: +46 8 750 3982

<u>Revision</u>	<u>Date</u>	<u>Status</u>
-----------------	-------------	---------------

1.5	07/98	Add pause, hardware reset, and software reset operational descriptions. Rewrite Design Recommendations to de-emphasize ground filtering. Change note 3 in Table 38 to RXD/RX_DV are driven at the start of SFD. Clarify bit 17.1, interrupt enable and bit 19.11, loopback.
-----	-------	---

The products listed in this publication are covered by one or more of the following patents. Additional patents pending.
5,008,637; 5,028,888; 5,057,794; 5,059,924; 5,068,628; 5,077,529; 5,084,866; 5,148,427; 5,153,875; 5,157,690; 5,159,291; 5,162,746; 5,166,635; 5,181,228;
5,204,880; 5,249,183; 5,257,286; 5,267,269; 5,267,746; 5,461,661; 5,493,243; 5,534,863; 5,574,726; 5,581,585; 5,608,341; 5,671,249; 5,666,129; 5,701,099

Copyright © 1998 Level One Communications, Inc. Specifications subject to change without notice.

All rights reserved. Printed in the United States of America.

PDS-T970-R1.5-0798