

CHARGE SENSITIVE PREAMPLIFIER - DISCRIMINATOR

A121

Model **A121** is a hybrid charge sensitive preamplifier-discriminator designed for use in fast pulse counting mode with microchannel plates, channel electron multipliers, low gain photomultiplier tubes, proportional counters and solid state detectors.

FEATURES:

- Fixed Dead Time
- Sensitivity: 5×10^4 electrons (Voltage Adjustable)
- Frequency: 12 MHz periodic
- Analog monitor output
- Output Pulse: 35 ns minimum (Adjustable)
- $V_s = +4$ to $+7$ VDC (25 mW)
- Input Noise: 15×10^{-16} coulombs RMS;
9,650 e^- RMS; 19% of threshold
- Noise Slope: 1.8×10^{-17} coulombs RMS/pF

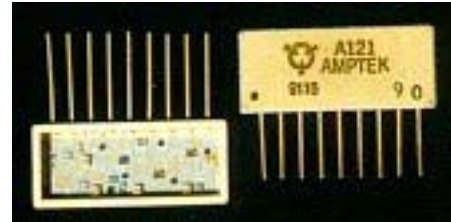

A121 DIMENSIONS

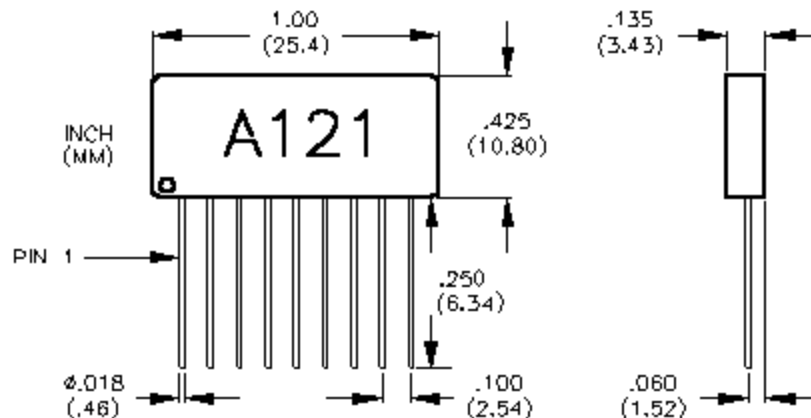

A121 RESPONSE

STEP INPUT THROUGH 2 pF TEST CAPACITOR

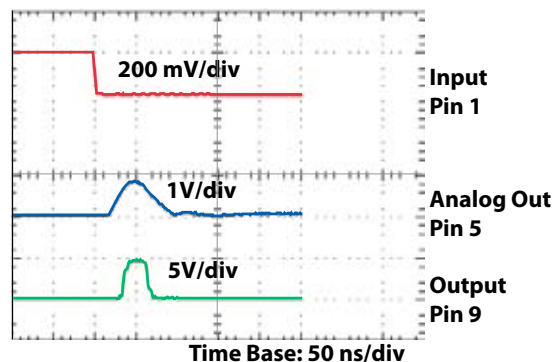

AMPTEK, INC. 14 DeAngelo Drive, Bedford, MA 01730-2204 USA

Tel: +1 (781) 275-2242 Fax: +1 (781) 275-3470 email: sales@amptek.com www.amptek.com

SPECIFICATIONS

Input Characteristics	
Threshold	Model A121 has a nominal threshold referred to the input of 8×10^{-15} coulomb. This is equivalent to 5×10^4 electrons.
Threshold Stability vs. Temperature	0.5% per °C
Threshold Stability vs. Power Supply Variations (Vs)	-0.1% per mV
Unit-to-Unit Threshold Variation	±8%
Noise (typical)	15×10^{-16} coulombs RMS; 9,650 e ⁻ RMS; 19% of threshold
Noise Slope (typical)	1.8×10^{-17} coulombs RMS/pF
Output Characteristics (At Threshold) Input Test: 4 mV through 2 pF Q = CV = 0.008 pC = 5×10^4 electrons	
Analog Output (Pin 5) Sensitivity	120 mV (15V/pC)
Analog Output Risetime	10 ns
Output (Pin 9)	5 V; 35 ns minimum
General	
Dead Time	Fixed Dead Time. Minimum Dead Time 80 ns. See figure A.
Count Rate	12×10^6 CPS periodic
Operating Voltage	+4 to +7 VDC (25 mW)
Operating Current (typical)	5 mA quiescent, plus 1.5 mA/MHz
Temperature	-55 to +85 °C operational
Screening	Amptek High Reliability (Optional NASA GS/FC S-311-P-698)
Warranty	One year
Weight	3.5 g
Package	9-pin SIP
Accessories	PC-121 test board

A121 PIN CONFIGURATION

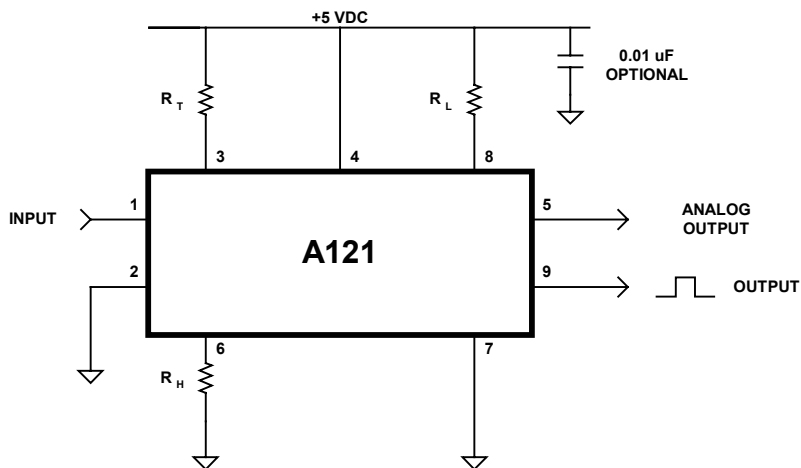

Pin 1	Input
Pin 2	Ground and case
Pin 3	Threshold Adjust (5k ohms $< R_T$; open for maximum sensitivity), see Figure B
Pin 4	V_S (+5 to +7 VDC MAX.)
Pin 5	Analog Monitor
Pin 6	Pulse Width Adjustment ($R_H < 30K$ ohms); $R_H = 0$ For Minimum Pulse Width of 35 ns, see Figure C
Pin 7	Ground and Case
Pin 8	Deadtime Adjustment ($R_L < 30K$ ohms); $R_L = 0$ For Minimum Deadtime of 80 ns, see Figure A
Pin 9	Output

Figure A

**A121 Typical Total Dead Time As A Function Of Resistance
From Pin 8 to +5 Volts DC**

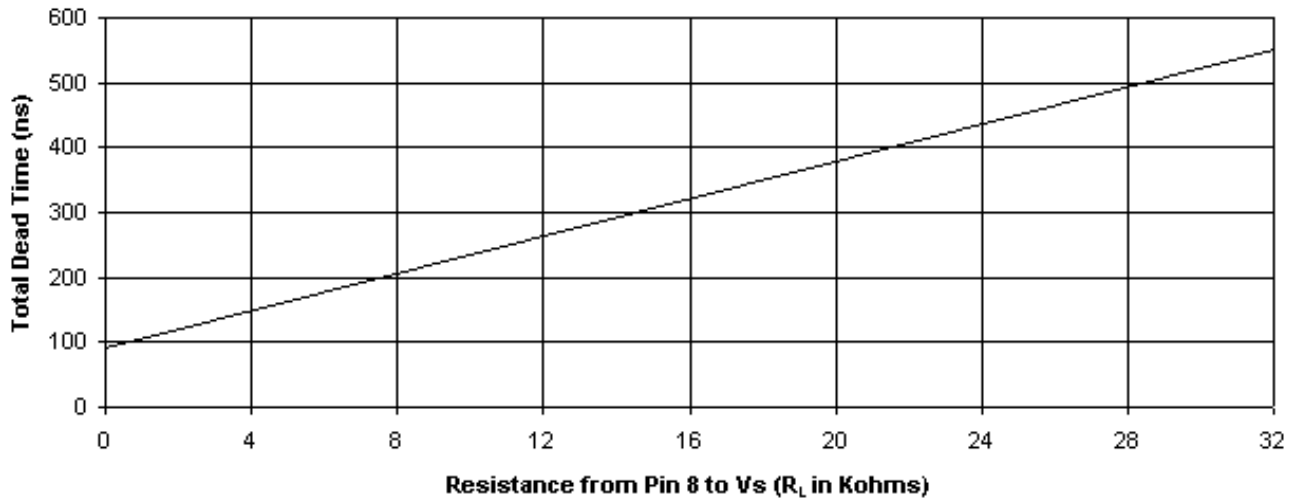

Figure B

**A121 Input Threshold Vs. Control Voltage on Pin 3
(at +50° C and -20° C)**

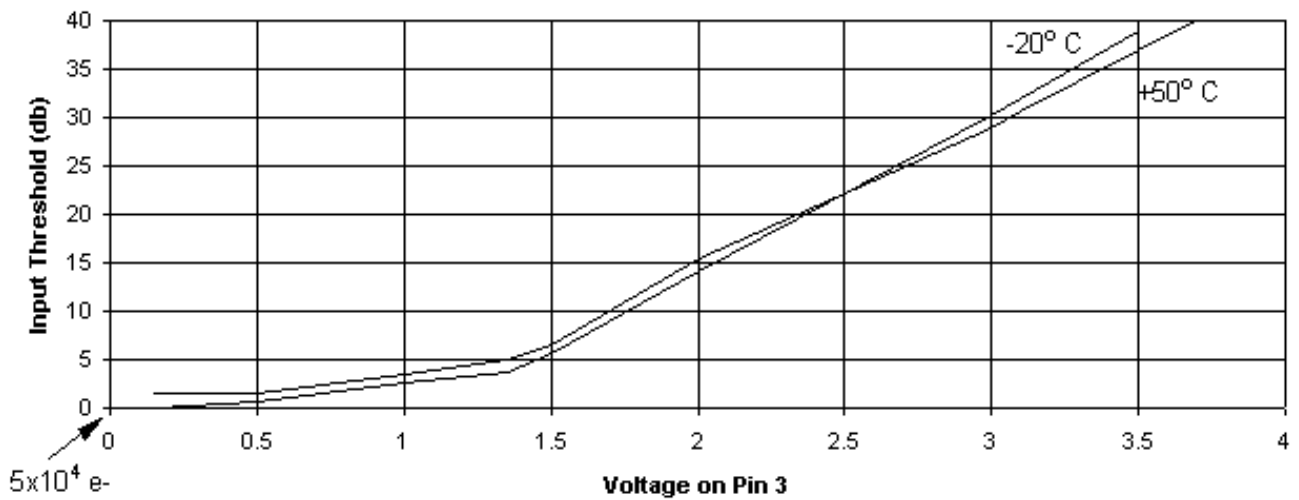
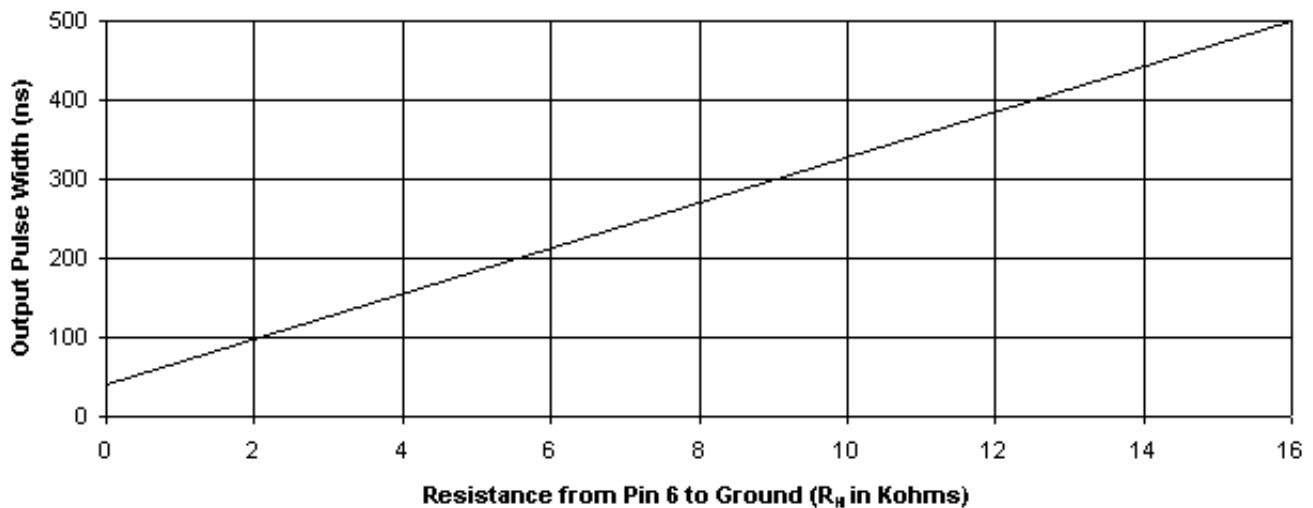

Figure C

**A121 Typical Output Pulse Width
Vs. Resistance to Ground from Pin 6**



NOTES ON A121

1. PIN 1, INPUT

Pin 1 has a DC level of 1.2 volts. This DC level should not be changed by external circuitry. Pin 1 should be AC coupled to the detector. The High Voltage coupling capacitor should have adequate voltage rating in order to prevent breakdown which could damage the A121.

For detectors with anode at ground potential:

An anode at ground potential needs a DC path to ground to maintain a fixed potential. This can be provided by DC coupling to the input of the A121, which will hold the anode at about 1.2 V. Alternatively, you can AC couple, but use a higher value resistor (1 MEG) to ground at the anode side of the capacitor.

2. Protection to the A121 can be provided as follows:

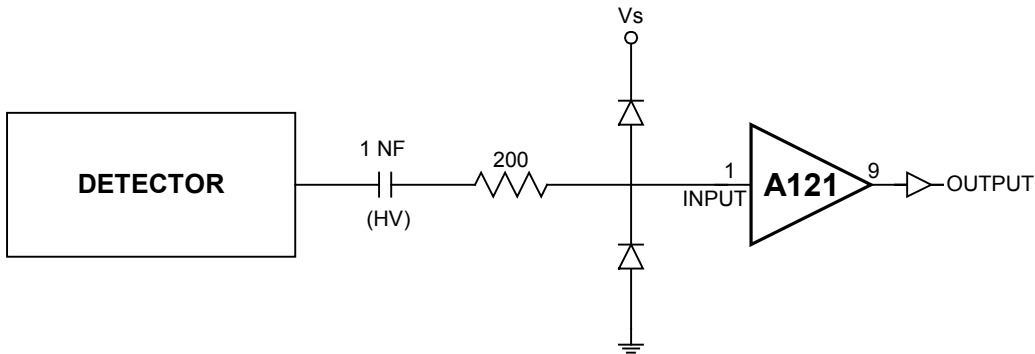

3. PIN 3, THRESHOLD ADJUST

Threshold to the A121 can be changed remotely by changing the voltage level on Pin 3. A resistor from Pin 3 to Vs can be added in order to raise the threshold on the A121. The impedance at Pin 3 is about 10k ohms. (See Figure B)

4. PIN 5, ANALOG MONITOR

Pin 5 provides a positive analog pulse output from the preamplifier section just prior to the discriminator with a rise time of about 10 ns. At maximum sensitivity (Pin 3 = 0 volts) the amplitude of this pulse is proportional to the input charge, $A = 15 \text{ V/pC}$. At threshold this will correspond to a 120 mV pulse. If a voltage is present on Pin 3, the size of the analog pulse will be divided by the same threshold attenuation factor the voltage produced. Example: If 1.3 volts is present on Pin 3 (6 dB attenuation is a factor of 2), the size of the analog pulse will be 60 mV. This output must be capacitively coupled to external circuitry and can be used to monitor detector gain variations by performing pulse height analysis.

5. PIN 9, OUTPUT

The final output stage of the A121 is produced from a 74AC00 gate with a 200 ohm series resistor.

PC121 Test Board for the A121

The PC121 is a printed circuit board designed to facilitate testing of the A121. Please see <http://www.amptek.com/a121.html> for complete specifications.

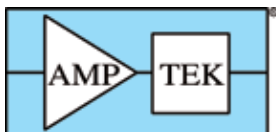

AMPTEK, INC. 14 DeAngelo Drive, Bedford, MA 01730-2204 USA
Tel: +1 (781) 275-2242 Fax: +1 (781) 275-3470
email: sales@amptek.com www.amptek.com