

# 233-303 RJ45 jack to solder cup wire termination MIL-DTL-38999 Series III type

How To Order 233-303									
Sample Part Number	233-303			NF	00	G	17	5L	N
Series / Basic Part No.	SuperSeal® RJ45 Connector								
Finish	NF = Cadmium Olive Drab ME = Electroless Nickel MT = Nickel PTFE								
Connector Style	00 = Square Flange Receptacle with Slotted Holes 07 = Jam Nut Receptacle								
Insert-to-Shell Grounding	G = Insert grounded to shell (for use with shielded cable)								
Shell Size	17 or 19								
Temperature Rating	5H = Cat5e, High Temp      6A = Cat6a, High Temp      5L = Cat5e, Low Temp								
Alternate Key Position	A, B, C, D, E, N = Normal; Per MIL-DTL-38999								

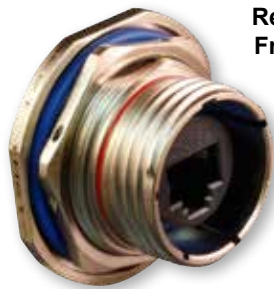

Receptacle Front View



Receptacle Rear View

For panel cut-out dimensions and electrical specifications see page E-3

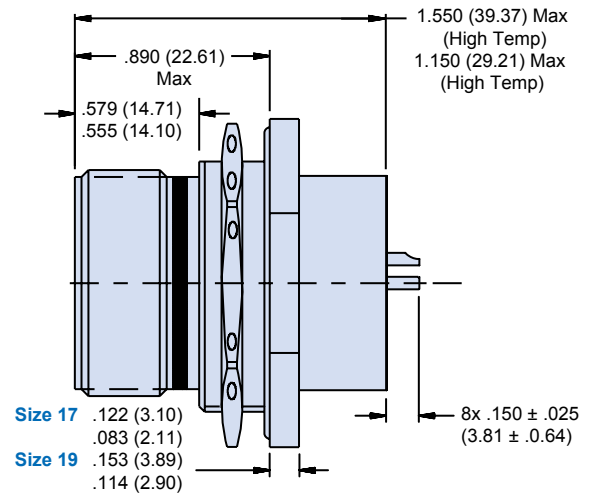
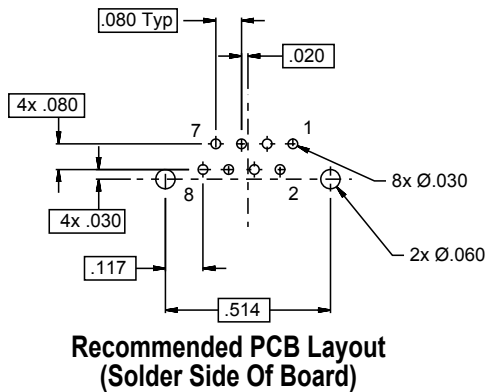

Square Flange Receptacle

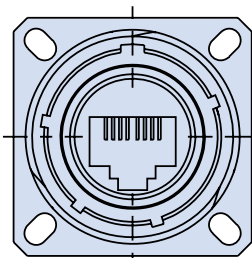

Receptacle Front View

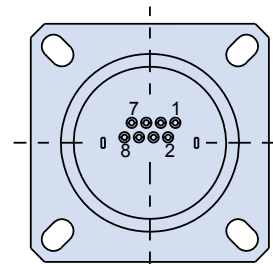
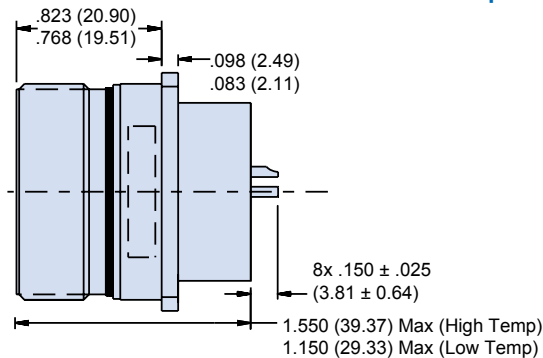

Receptacle Rear View