



TC7136
TC7136A

LOW POWER, 3-1/2 DIGIT ANALOG-TO-DIGITAL CONVERTERS

FEATURES

- Fast Overrange Recovery, Guaranteed First Reading Accuracy
- Low Temperature Drift Internal Reference
 - TC713670 ppm/°C Typ
 - TC7136A35 ppm/°C Typ
- Guaranteed Zero Reading With Zero Input
- Low Noise15 μ V_{P-P}
- High Resolution0.05%
- Wide Dynamic Range72 dB
- Low Input Leakage Current1 pA Typ
10 pA Max
- Direct LCD Drive — No External Components
- Precision Null Detectors With True Polarity at Zero
- High-Impedance Differential Input
- Convenient 9V Battery Operation With Low Power Dissipation500 μ W Typ
900 μ W Max
- Internal Clock Circuit
- Available in Compact Flat Package or PLCC
- Industrial Temperature Range Device Available

TYPICAL APPLICATIONS

- Thermometry
- Bridge Readouts
 - Strain Gauges
 - Load Cells
 - Null Detectors
- Digital Meters
 - Voltage/Current/Ohms/Power
 - pH
 - Capacitance/Inductance
 - Fluid Flow Rate/Viscosity/Level
 - Humidity
 - Position
- Digital Scales
- Panel Meters
- LVDT Indicators
- Portable Instrumentation
- Power Supply Readouts
- Process Monitors
- Gaussmeters
- Photometers

TYPICAL OPERATING CIRCUIT

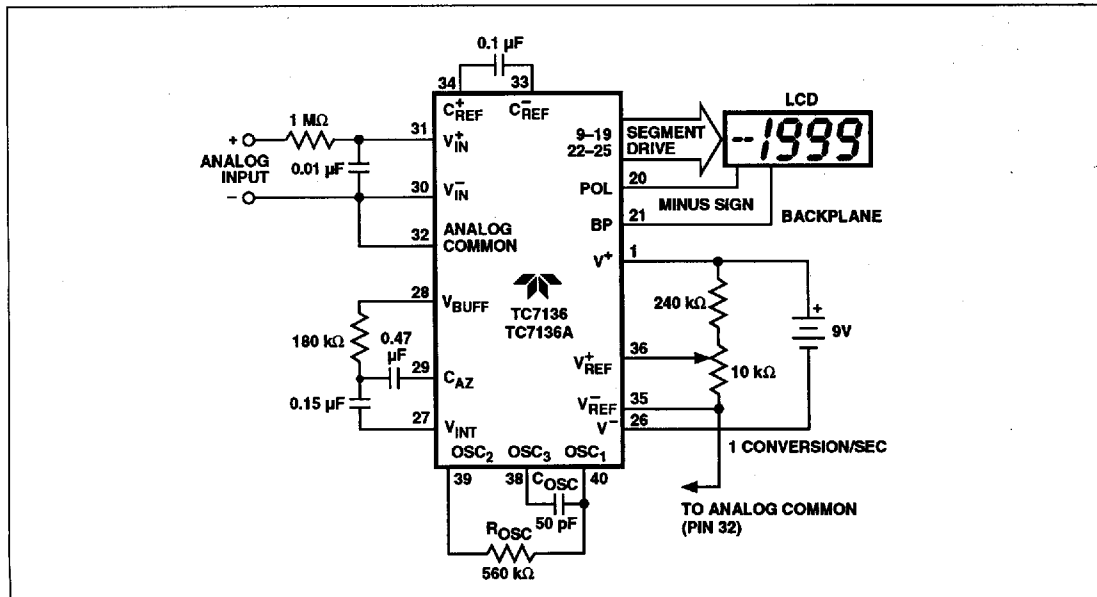

T-51-10-05

LOW POWER, 3-1/2 DIGIT ANALOG-TO-DIGITAL CONVERTERS

TC7136 TC7136A

GENERAL DESCRIPTION

The TC7136 and TC7136A are low-power, 3-1/2 digit, liquid crystal display (LCD), analog-to-digital converters (ADCs). These devices incorporate an "integrator output zero" phase which guarantees overrange recovery. The performance of existing TC7126, TC7126A and ICL7126-based systems may be upgraded with minor changes to external, passive components.

The TC7136A has an improved internal zener reference voltage circuit which maintains the analog common temperature drift to 35 ppm/°C (typical) and 75 ppm/°C (maximum). This represents an improvement of two to four times over similar 3-1/2 digit converters. The costly, space-consuming external reference source may be removed.

The TC7136 limits linearity error to less than 1 count on 200 mV or 2V full-scale ranges. Roll-over error — the difference in readings for equal magnitude but opposite polarity input signals — is below ±1 count. High-impedance differential inputs offer 1 pA leakage currents and a $10^{12}\Omega$ input impedance. The differential reference input allows

ratio-metric measurements for ohms or bridge transducer measurements. The $15\mu\text{V}_{\text{p-p}}$ noise performance guarantees a "rock solid" reading. The auto-zero cycle guarantees a zero display readout for a 0V input.

The single-chip CMOS TC7136 incorporates all the active devices for a 3-1/2 digit ADC to directly drive an LCD. The internal oscillator, precision voltage reference, and display segment/backplane drivers simplify system integration, reduce board space requirements and lower total cost. A low-cost, high-resolution (0.05%) indicating meter requires only a display, four resistors, four capacitors and a 9V battery. The flat package option eases the mechanical design of low-cost, hand-held multimeters.

The TC7136A dual-slope conversion technique rejects interference signals if the converter's integration time is set to a multiple of the interference signal period. This is especially useful in industrial measurement environments where 50 Hz, 60 Hz, and 400 Hz line frequency signals are present.

ORDERING INFORMATION

Part No.	Package	Pin Layout	Temperature Range	Reference Temperature Coefficient (Max)
TC7136ACPL	40-Pin Plastic DIP	Normal	0°C to +70°C	75 ppm/°C
TC7136CPL				150 ppm/°C
TC7136ARCPL	40-Pin Plastic DIP	Reversed	0°C to +70°C	75 ppm/°C
TC7136RCPL				150 ppm/°C
TC7136AIJL	40-Pin CerDIP	Normal	-25°C to +85°C	100 ppm/°C
TC7136IJL				150 ppm/°C
TC7136ACKW	44-Pin Plastic Flat	Formed Leads	0°C to +70°C	75 ppm/°C
TC7136CKW				150 ppm/°C
TC7136ACLW	44-Pin PLCC		0°C to +70°C	75 ppm/°C
TC7136CLW				150 ppm/°C

LOW POWER, 3-1/2 DIGIT
ANALOG-TO-DIGITAL CONVERTERS

1

TC7136
TC7136A

PIN CONFIGURATIONS

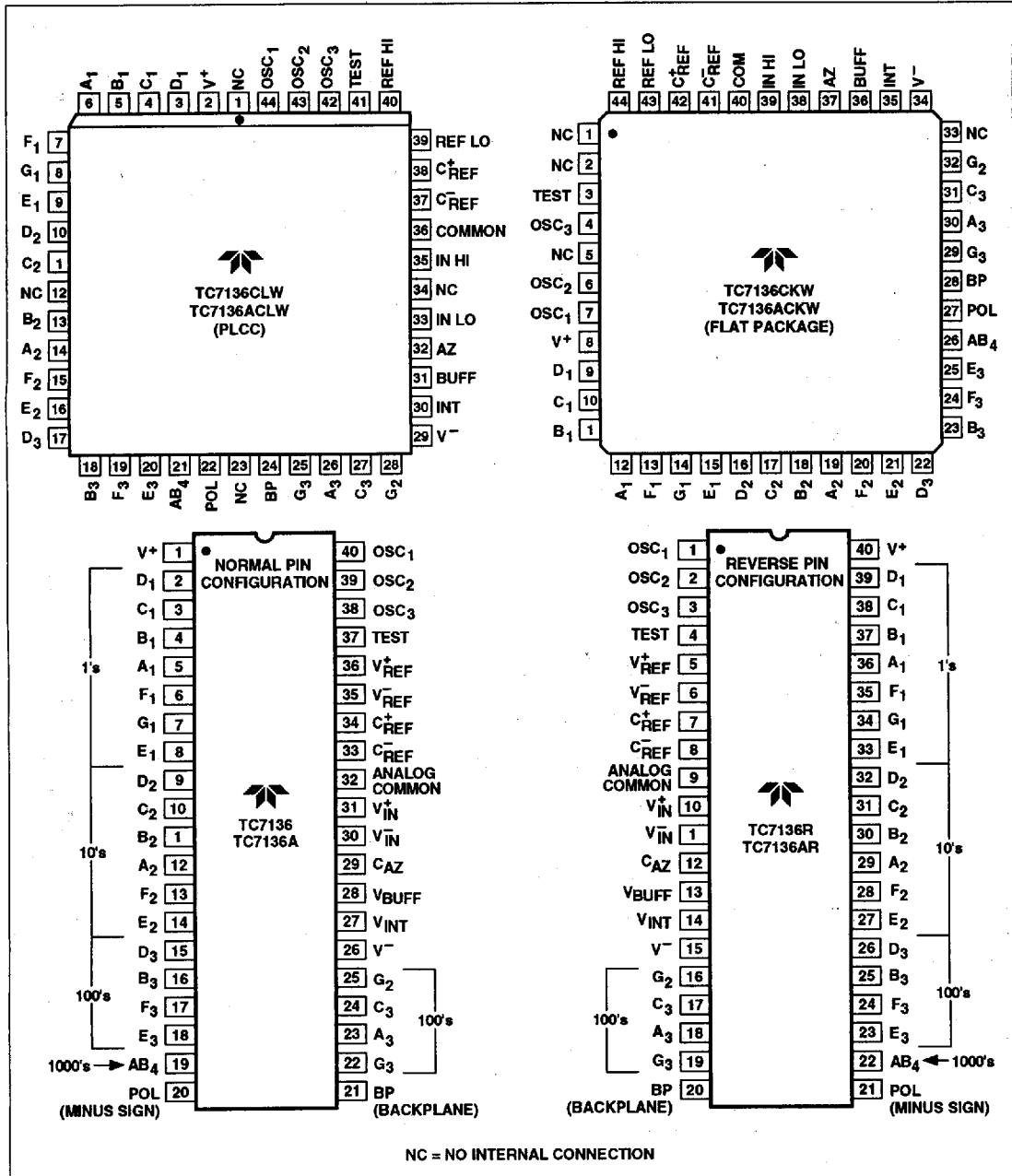

T-51-10-05

LOW POWER, 3-1/2 DIGIT ANALOG-TO-DIGITAL CONVERTERS

TC7136
TC7136A

ABSOLUTE MAXIMUM RATINGS

Supply Voltage (V^+ to V^-)	+15V
Analog Input Voltage (Either Input) (Note 1)	V^+ to V^-
Reference Input Voltage (Either Input)	V^+ to V^-
Clock Input	TEST to V^+
Power Dissipation (Note 2)	
CerDIP (J)	1000 mW
Plastic DIP (P)	800 mW
Flat Package (K, L)	500 mW
Operating Temperature Range	
C Devices	0°C to +70°C
I Devices	-25°C to +85°C

Storage Temperature Range	-65°C to +150°C
Lead Temperature (Soldering, 60 sec)	+300°C

Static-sensitive device. Unused devices must be stored in conductive material. Protect devices from static discharge and static fields. Stresses above those listed under Absolute Maximum Ratings may cause permanent damage to the device. These are stress ratings only and functional operation of the device at these or any other conditions above those indicated in the operational sections of the specifications is not implied. Exposure to Absolute Maximum Rating Conditions for extended periods may affect device reliability.

ELECTRICAL CHARACTERISTICS: $V_S = 9V$, $f_{CLK} = 16$ kHz, and $T_A = +25^\circ C$, unless otherwise noted.

Symbol	Parameter	Test Conditions	Min	Typ	Max	Unit
Input						
	Zero Input Reading	$V_{IN} = 0V$ Full Scale = 200 mV	-000.0	±000.0	+000.0	Digital Reading
	Zero Reading Drift	$V_{IN} = 0V$, $0^\circ C \leq T_A \leq +70^\circ C$	—	0.2	1	$\mu V/^\circ C$
	Ratiometric Reading	$V_{IN} = V_{REF}$, $V_{REF} = 100$ mV	999	999/1000	1000	Digital Reading
NL	Nonlinearity Error	Full Scale = 200 mV or 2V Max Deviation From Best Straight Line	-1	±0.2	1	Count
	Roll-Over Error	$-V_{IN} = +V_{IN} = 200$ mV	-1	±0.2	1	Count
e_N	Noise	$V_{IN} = 0V$, Full Scale = 200 mV	—	15	—	μV_{P-P}
I_L	Input Leakage Current	$V_{IN} = 0V$	—	1	10	pA
CMRR	Common-Mode Rejection Ratio	$V_{CM} = \pm 1V$, $V_{IN} = 0V$, Full Scale = 200 mV	—	50	—	$\mu V/V$
	Scale Factor Temperature Coefficient	$V_{IN} = 199$ mV, $0^\circ C \leq T_A \leq +70^\circ C$ Ext Ref Temp Coeff = 0 ppm/°C	—	1	5	ppm/°C
Analog Common						
V_{CTC}	Analog Common Temperature Coefficient	250 k Ω Between Common and V^+ $0^\circ C \leq T_A \leq +70^\circ C$ TC7136A "C" Commercial Temp TC7136 Range Devices	—	35	75	ppm/°C
		-25°C ≤ T_A ≤ +85°C TC7136A "I" Industrial Temp TC7136 Range Devices	—	35	100	ppm/°C
			—	70	150	ppm/°C
V_C	Analog Common Voltage	250 k Ω Between Common and V^+	2.7	3.05	3.35	V
LCD Drive						
V_{SD}	LCD Segment Drive Voltage	V^+ to $V^- = 9V$	4	5	6	V_{P-P}
V_{BD}	LCD Backplane Drive Voltage	V^+ to $V^- = 9V$	4	5	6	V_{P-P}
Power Supply						
I_S	Power Supply Current	$V_{IN} = 0V$, V^+ to $V^- = 9V$ (Note 6)	—	70	100	μA

- NOTES: 1. Input voltages may exceed supply voltages when input current is limited to 100 μA .
 2. Dissipation rating assumes device is mounted with all leads soldered to PC board.
 3. Refer to "Differential Input" discussion.
 4. Backplane drive is in-phase with segment drive for "off" segment and 180° out-of-phase for "on" segment. Frequency is 20 times conversion rate. Average DC component is less than 50 mV.
 5. See "Typical Operating Circuit".
 6. A 48 kHz oscillator increases current by 20 μA (typical). Common current not included.

T-51-10-05

LOW POWER, 3-1/2 DIGIT ANALOG-TO-DIGITAL CONVERTERS

1

TC7136
TC7136A

PIN DESCRIPTION

40-Pin DIP			
Pin Number	Normal	(Reverse)	Name Description
1		(40)	V ⁺ Positive supply voltage.
2		(39)	D ₁ Activates the D section of the units display.
3		(38)	C ₁ Activates the C section of the units display.
4		(37)	B ₁ Activates the B section of the units display.
5		(36)	A ₁ Activates the A section of the units display.
6		(35)	F ₁ Activates the F section of the units display.
7		(34)	G ₁ Activates the G section of the units display.
8		(33)	E ₁ Activates the E section of the units display.
9		(32)	D ₂ Activates the D section of the tens display.
10		(31)	C ₂ Activates the C section of the tens display.
11		(30)	B ₂ Activates the B section of the tens display.
12		(29)	A ₂ Activates the A section of the tens display.
13		(28)	F ₂ Activates the F section of the tens display.
14		(27)	E ₂ Activates the E section of the tens display.
15		(26)	D ₃ Activates the D section of the hundreds display.
16		(25)	B ₃ Activates the B section of the hundreds display.
17		(24)	F ₃ Activates the F section of the hundreds display.
18		(23)	E ₃ Activates the E section of the hundreds display.
19		(22)	AB ₄ Activates both halves of the 1 in the thousands display.
20		(21)	POL Activates the negative polarity display.
21		(20)	BP Backplane drive output.
22		(19)	G ₃ Activates the G section of the hundreds display.
23		(18)	A ₃ Activates the A section of the hundreds display.
24		(17)	C ₃ Activates the C section of the hundreds display.
25		(16)	G ₂ Activates the G section of the tens display.
26		(15)	V ⁻ Negative power supply voltage.
27		(14)	V _{INT} The integrating capacitor should be selected to give the maximum voltage swing that ensures component tolerance build-up will not allow the integrator output to saturate. When analog common is used as a reference and the conversion rate is 3 readings per second, a 0.047 μF capacitor may be used. The capacitor must have a low dielectric constant to prevent roll-over errors. See Integrating Capacitor section for additional details.
28		(13)	V _{BUFF} Integration resistor connection. Use a 180 kΩ for a 200 mV full-scale range and a 1.8 MΩ for 2V full-scale range.
29		(12)	C _{AZ} The size of the auto-zero capacitor influences the system noise. Use a 0.47 μF capacitor for a 200 mV full scale, and a 0.1 μF capacitor for a 2V full scale. See paragraph on Auto-Zero Capacitor for more details.
30		(11)	V _{IN} ⁻ The low input signal is connected to this pin.
31		(10)	V _{IN} ⁺ The high input signal is connected to this pin.
32		(9)	ANALOG COMMON This pin is primarily used to set the analog common-mode voltage for battery operation or in systems where the input signal is referenced to the power supply. See paragraph on Analog Common for more details. It also acts as a reference voltage source.
33		(8)	C _{REF} ⁻ See pin 34.

T-51-10-05

LOW POWER, 3-1/2 DIGIT ANALOG-TO-DIGITAL CONVERTERS

TC7136 TC7136A

PIN DESCRIPTION (Cont.)

40-Pin DIP				
Pin Number	Normal	(Reverse)	Name	Description
34	(7)		C_{REF}^+	A 0.1 μ F capacitor is used in most applications. If a large common-mode voltage exists (for example, the V_{IN}^- pin is not at analog common), and a 200 mV scale is used, a 1 μ F capacitor is recommended and will hold the roll-over error to 0.5 count.
35	(6)		V_{REF}^-	See pin 36.
36	(5)		V_{REF}^+	The analog input required to generate a full-scale output (1999 counts). Place 100 mV between pins 35 and 36 for 199.9 mV full scale. Place 1V between pins 35 and 36 for 2V full scale. See paragraph on Reference Voltage.
37	(4)		TEST	Lamp test. When pulled high (to V^+) all segments will be turned on and the display should read -1888. It may also be used as a negative supply for externally-generated decimal points. See paragraph under Test for additional information.
38	(3)		OSC ₃	See pin 40.
39	(2)		OSC ₂	See pin 40.
40	(1)		OSC ₁	Pins 40, 39 and 38 make up the oscillator section. For a 48 kHz clock (3 readings per second) connect pin 40 to the junction of a 180 k Ω resistor and a 50 pF capacitor. The 180 k Ω resistor is tied to pin 39 and the 50 pF capacitor is tied to pin 38.

GENERAL THEORY OF OPERATION

Dual-Slope Conversion Principles

The TC7136A is a dual-slope, integrating analog-to-digital converter. An understanding of the dual-slope conversion technique will aid in following detailed TC7136A operational theory.

The conventional dual-slope converter measurement cycle has two distinct phases:

- (1) Input signal integration
- (2) Reference voltage integration (deintegration)

The input signal being converted is integrated for a fixed time period (t_{SI}), measured by counting clock pulses. An opposite polarity constant reference voltage is then integrated until the integrator output voltage returns to zero. The reference integration time is directly proportional to the input signal (t_{RI}).

In a simple dual-slope converter, a complete conversion requires the integrator output to "ramp-up" and "ramp-down."

A simple mathematical equation relates the input signal, reference voltage, and integration time:

$$\frac{1}{RC} \int_0^{t_{SI}} V_{IN}(t) dt = \frac{V_R t_{RI}}{RC}$$

where:

- V_R = Reference voltage
- t_{SI} = Signal integration time (fixed)
- t_{RI} = Reference voltage integration time (variable).

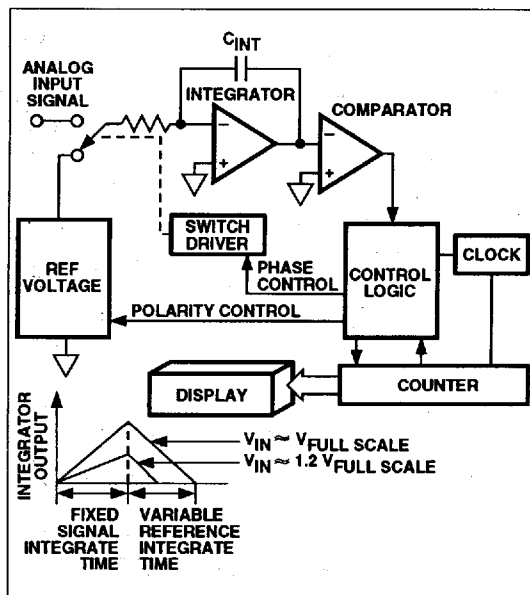

Figure 1 Basic Dual-Slope Converter

For a constant V_{IN} :

$$V_{IN} = V_R \left[\frac{t_{RI}}{t_{SI}} \right]$$

LOW POWER, 3-1/2 DIGIT ANALOG-TO-DIGITAL CONVERTERS

TC7136
TC7136A

1

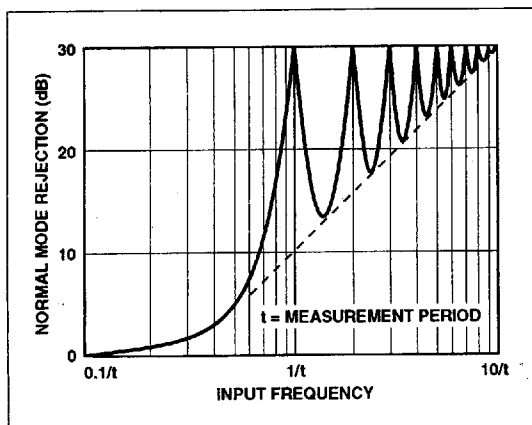

Figure 2 Normal-Mode Rejection of Dual-Slope Converter

The dual-slope converter accuracy is unrelated to the integrating resistor and capacitor values, as long as they are stable during a measurement cycle. Noise immunity is an inherent benefit. Noise spikes are integrated, or averaged, to zero during integration periods. Integrating ADCs are immune to the large conversion errors that plague successive approximation converters in high-noise environments. Interfering signals with frequency components at multiples of the averaging period will be attenuated. Integrating ADCs commonly operate with the signal integration period set to a multiple of the 50 Hz/60 Hz power line period.

ANALOG SECTION

In addition to the basic integrate and deintegrate dual-slope cycles discussed above, the TC7136 and TC7136A designs incorporate an "integrator output-zero cycle" and an "auto-zero cycle." These additional cycles ensure the integrator starts at 0V (even after a severe overrange conversion) and that all offset voltage errors (buffer amplifier, integrator and comparator) are removed from the conversion. A true digital zero reading is assured without any external adjustments.

A complete conversion consists of four distinct phases:

- (1) Integrator output-zero phase
- (2) Auto-zero phase
- (3) Signal integrate phase
- (4) Reference deintegrate phase

Integrator Output-Zero Phase

This phase guarantees the integrator output is at 0V before the system-zero phase is entered. This ensures that true system offset voltages will be compensated for, even

after an overrange conversion. The count for this phase is a function of the number of counts required by the deintegrate phase.

The count lasts from 11 to 140 counts for non-overrange conversions and from 31 to 640 counts for overrange conversions.

Auto-Zero Phase

During the auto-zero phase, the differential input signal is disconnected from the circuit by opening internal analog gates. The internal nodes are shorted to analog common (ground) to establish a zero input condition. Additional analog gates close a feedback loop around the integrator and comparator. This loop permits comparator offset voltage error compensation. The voltage level established on C_{AZ} compensates for device offset voltages. The auto-zero phase residual is typically 10 μ V to 15 μ V.

The auto-zero duration is from 910 to 2900 counts for non-overrange conversions and from 300 to 910 counts for overrange conversions.

Signal Integration Phase

The auto-zero loop is entered and the internal differential inputs connect to V_{IN}^+ and V_{IN}^- . The differential input signal is integrated for a fixed time period. The TC7136A signal integration period is 1000 clock periods or counts. The externally-set clock frequency is divided by four before clocking the internal counters. The integration time period is:

$$t_{SI} = \frac{4}{f_{OSC}} \times 1000,$$

where f_{OSC} = external clock frequency.

The differential input voltage must be within the device common-mode range when the converter and measured system share the same power supply common (ground). If the converter and measured system do not share the same power supply common, V_{IN}^- should be tied to analog common.

Polarity is determined at the end of signal integrate phase. The sign bit is a true polarity indication, in that signals less than 1 LSB are correctly determined. This allows precision null detection limited only by device noise and auto-zero residual offsets.

Reference Integrate Phase

The third phase is reference integrate or deintegrate. V_{IN}^- is internally connected to analog common and V_{IN}^+ is connected across the previously-charged reference capacitor. Circuitry within the chip ensures the capacitor will be connected with the correct polarity to cause the integrator output to return to zero. The time required for the output to

T-51-10-05

LOW POWER, 3-1/2 DIGIT
ANALOG-TO-DIGITAL CONVERTERS

TC7136
TC7136A

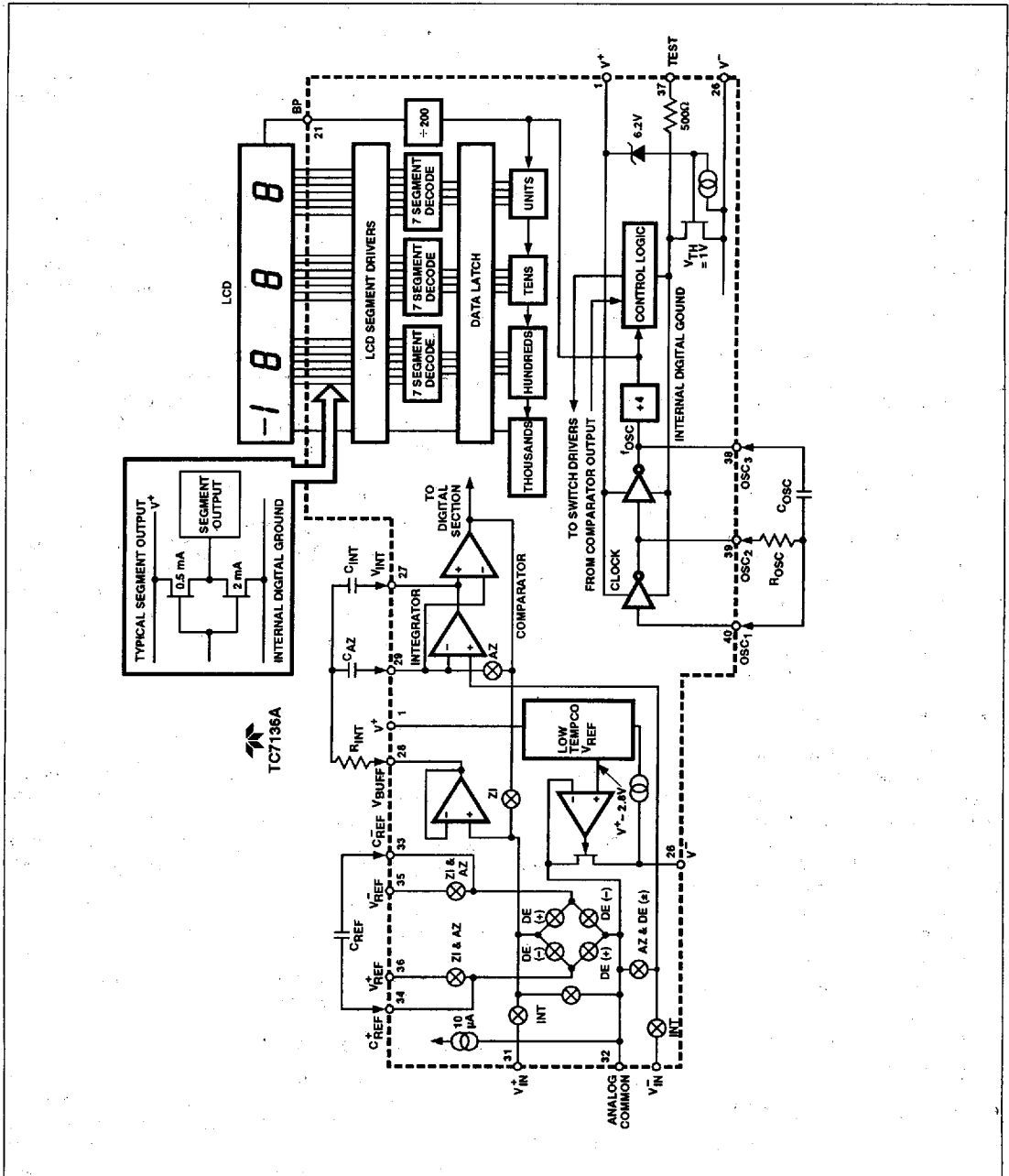

Figure 3 TC7136A Block Diagram

LOW POWER, 3-1/2 DIGIT ANALOG-TO-DIGITAL CONVERTERS

TC7136
TC7136A

1

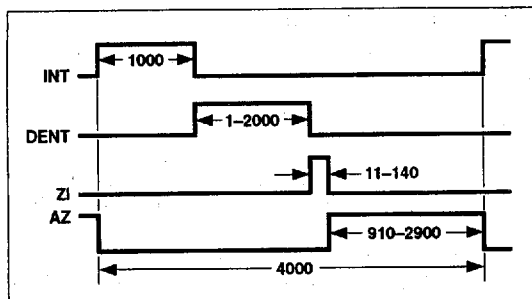

Figure 4 Conversion Timing During Normal Operation

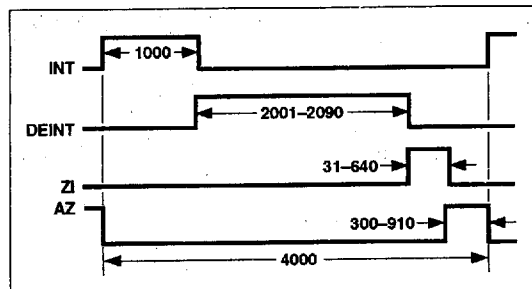

Figure 5 Conversion Timing During Overrange Operation

return to zero is proportional to the input signal and is between 0 and 2000 internal clock periods. The digital reading displayed is

$$1000 \frac{V_{IN}}{V_{REF}}$$

DIGITAL SECTION

The TC7136A contains all the segment drivers necessary to directly drive a 3-1/2 digit LCD. An LCD backplane driver is included. The backplane frequency is the external clock frequency divided by 800. For three conversions per second the backplane frequency is 60 Hz with a 5V nominal amplitude. When a segment driver is in-phase with the backplane signal, the segment is "OFF." An out-of-phase segment drive signal causes the segment to be "ON," or visible. This AC drive configuration results in negligible DC voltage across each LCD segment, ensuring long LCD life. The polarity segment driver is "ON" for negative analog inputs. If V_{IN}^+ and V_{IN}^- are reversed, this indicator would reverse.

On the TC7136A, when the test pin is pulled to V^+ , all segments are turned "ON." The display reads -1888. During this mode the LCD segments have a constant DC voltage impressed. Do not leave the display in this mode for more

than several minutes. LCDs may be destroyed if operated with DC levels for extended periods.

The display font and segment drive assignment are shown in Figure 6.

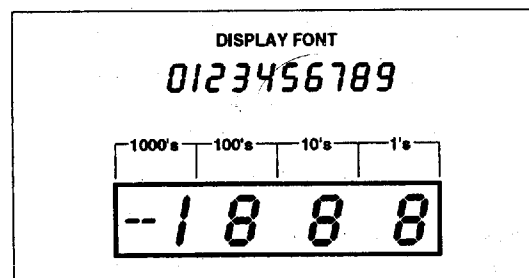

Figure 6 Display FONT and Segment Assignment

System Timing

The oscillator frequency is divided by 4 prior to clocking the internal decade counters. The four-phase measurement cycle takes a total of 4000 counts, or 16,000 clock pulses. The 4000-count cycle is independent of input signal magnitude.

Each phase of the measurement cycle has the following length:

- (1) Auto-zero phase: 3000 to 2900 counts
(1200 to 11,600 clock pulses)
- (2) Signal integrate: 1000 counts
(4000 clock pulses)

This time period is fixed. The integration period is:

$$t_{SI} = 4000 \left[\frac{1}{f_{OSC}} \right]$$

where f_{OSC} is the externally-set clock frequency.

- (3) Reference integrate: 0 to 2000 counts
- (4) Zero integrator: 11 to 640 counts

The TC7136 is a drop-in replacement for the TC7126 and ICL7126. The TC7136A offers a greatly-improved internal reference temperature coefficient. Minor component value changes are required to upgrade existing designs and improve the noise performance.

COMPONENT VALUE SELECTION

Auto-Zero Capacitor (C_{AZ})

The C_{AZ} capacitor size has some influence on system noise. A 0.47 μF capacitor is recommended for 200 mV full-scale applications where 1 LSB is 100 μV . A 0.1 μF capacitor is adequate for 2V full-scale applications. A Mylar-type dielectric capacitor is adequate.

T-51-10-05

LOW POWER, 3-1/2 DIGIT ANALOG-TO-DIGITAL CONVERTERS

TC7136 TC7136A

Reference Voltage Capacitor (C_{REF})

The reference voltage used to ramp the integrator output voltage back to zero during the reference integrate phase is stored on C_{REF} . A 0.1 μF capacitor is acceptable when V_{REF^-} is tied to analog common. If a large common-mode voltage exists ($V_{REF^-} \neq$ analog common) and the application requires a 200 mV full scale, increase C_{REF} to 1 μF . Roll-over error will be held to less than 0.5 count. A Mylar-type dielectric capacitor is adequate.

Integrating Capacitor (C_{INT})

C_{INT} should be selected to maximize integrator output voltage swing without causing output saturation. Analog common will normally supply the differential voltage reference this case, a $\pm 2\text{V}$ full-scale integrator output swing is satisfactory. For 3 readings per second ($f_{OSC} = 48 \text{ kHz}$) a 0.047 μF value is suggested. For one reading per second, 0.15 μF is recommended. If a different oscillator frequency is used, C_{INT} must be changed in inverse proportion to maintain the nominal $\pm 2\text{V}$ integrator swing.

An exact expression for C_{INT} is:

$$C_{INT} = \frac{(4000) \left(\frac{1}{f_{OSC}} \right) \left(\frac{V_{FS}}{R_{INT}} \right)}{V_{INT}}$$

where: f_{OSC} = Clock frequency at pin 38
 V_{FS} = Full-scale input voltage
 R_{INT} = Integrating resistor
 V_{INT} = Desired full-scale integrator output swing.

C_{INT} must have low dielectric absorption to minimize roll-over error. An inexpensive polypropylene capacitor is recommended.

Integrating Resistor (R_{INT})

The input buffer amplifier and integrator are designed with Class A output stages. The output stage idling current is 6 μA . The integrator and buffer can supply 1 μA drive currents with negligible linearity errors. R_{INT} is chosen to remain in the output stage linear drive region, but not so large that PC board leakage currents induce errors. For a 200 mV full scale, R_{INT} is 180 k Ω . A 2V full scale requires 1.8 M Ω .

Component	Nominal Full-Scale Voltage	
	200 mV	2V
C_{AZ}	0.47 μF	0.1 μF
R_{INT}	180 k Ω	1.8 M Ω
C_{INT}	0.047 μF	0.047 μF

NOTE: $f_{OSC} = 48 \text{ kHz}$ (3 readings per sec). $R_{OSC} = \text{k}\Omega$, $C_{OSC} = 50 \text{ pF}$.

Oscillator Components

C_{OSC} should be 50 pF. R_{OSC} is selected from the equation:

$$f_{OSC} = \frac{0.45}{RC}$$

Note that f_{OSC} is $\div 4$ to generate the TC7136A's internal clock. The backplane drive signal is derived by dividing f_{OSC} by 800.

To achieve maximum rejection of 60 Hz noise pickup, the signal integrate period should be a multiple of 60 Hz. Oscillator frequencies of 240 kHz, 120 kHz, 80 kHz, 60 kHz, 40 kHz, 33-1/3 kHz, etc. should be selected. For 50 Hz rejection, oscillator frequencies of 200 kHz, 100 kHz, 66-2/3 kHz, 50 kHz, 40 kHz, etc. would be suitable. Note that 40 kHz (2.5 readings per second) will reject both 50 Hz and 60 Hz (also 400 Hz and 440 Hz).

Reference Voltage Selection

A full-scale reading (2000 counts) requires the input signal be twice the reference voltage.

Required Full-Scale Voltage*	V_{REF}
200 mV	100 mV
2V	1V

* $V_{FS} = 2 V_{REF}$.

In some applications, a scale factor other than unity may exist between a transducer output voltage and the required digital reading. Assume, for example, a pressure transducer output for 2000 lb/in.² is 400 mV. Rather than dividing the input voltage by two, the reference voltage should be set to 200 mV. This permits the transducer input to be used directly.

The differential reference can also be used when a digital zero reading is required when V_{IN} is not equal to zero. This is common in temperature measuring instrumentation. A compensating offset voltage can be applied between analog common and V_{IN^-} . The transducer output is connected between V_{IN^+} and analog common.

DEVICE PIN FUNCTIONAL DESCRIPTION

Differential Signal Inputs

V_{IN^+} (Pin 31), V_{IN^-} (Pin 30)

The TC7136A is designed with true differential inputs and accepts input signals within the input stage common-mode voltage range (V_{COM}). The typical range is $V^+ - 1\text{V}$ to $V^- + 1\text{V}$. Common-mode voltages are removed from the system when the TC7136A operates from a battery or floating power source (isolated from measured system), and V_{IN^-} is connected to analog common (V_{COM}). (See Figure 7.)

T-51-10-05

LOW POWER, 3-1/2 DIGIT ANALOG-TO-DIGITAL CONVERTERS

TC7136 TC7136A

With sufficiently high total supply voltage ($V^+ - V^- > 7V$), analog common is a very stable potential with excellent temperature stability (typically 35 ppm/°C). This potential can be used to generate the TC7136A's reference voltage. An external voltage reference will be unnecessary in most cases because of the 35 ppm/°C temperature coefficient. See TC7136A Internal Voltage Reference discussion.

TEST (Pin 37)

The test pin potential is 5V less than V^+ . Test may be used as the negative power supply connection for external CMOS logic. The test pin is tied to the internally-generated negative logic supply through a 500Ω resistor. The test pin load should not be more than 1 mA. See the Applications Section for additional information on using test as a negative digital logic supply.

If test is pulled high (to V^+), all segments plus the minus sign will be activated. Do not operate in this mode for more than several minutes. With Test = V^+ , the LCD segments are impressed with a DC voltage which will destroy the LCD.

TC7136A Internal Voltage Reference

The TC7136 analog common voltage temperature stability has been significantly improved (Figure 9). The "A" version of the industry-standard TC7136 device allows users to upgrade old systems and design new systems without external voltage references. External R and C values do not need to be changed; however, noise performance will be improved by increasing C_{AZ} . (See Auto-Zero Capacitor section.) Figure 10 shows analog common supplying necessary voltage reference for the TC7136A.

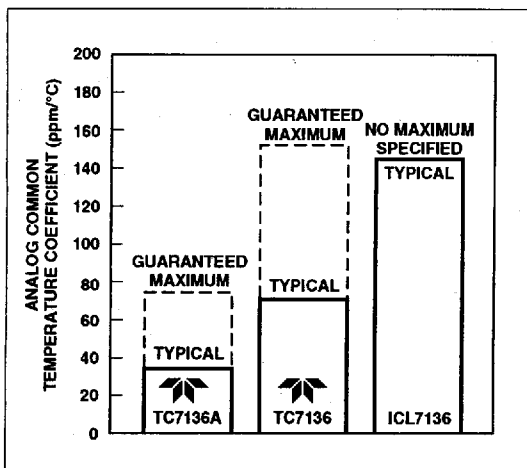

Figure 9 Analog Common Temperature Coefficient

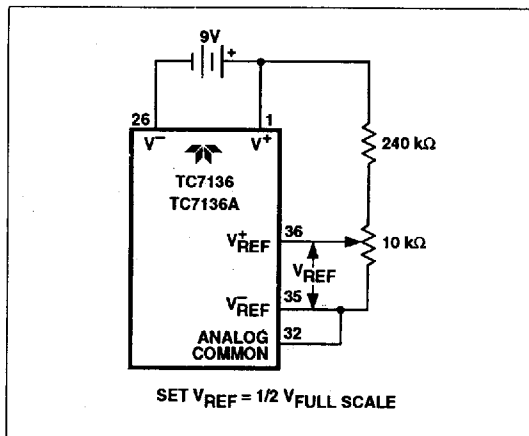

Figure 10 TC7136A Internal Voltage Reference Connection

APPLICATIONS INFORMATION

Liquid Crystal Display Sources

Several manufacturers supply standard LCDs to interface with the TC7136A 3-1/2 digit analog-to-digital converter.

Manufacturer	Address/Phone	Representative Part Numbers*
Crystaloid Electronics	5282 Hudson Dr., Hudson, OH 44236 216-655-2429	C5335, H5535, T5135, SX440
AND	770 Airport Blvd., Burlingame, CA 94010 415-347-9916	FE 0801, FE 0203
VGI, Inc.	1800 Vernon St., Ste. 2 Roseville, CA 95678 916-783-7878	11048, 11126
Hamlin, Inc.	612 E. Lake St., Lake Mills, WI 53551 414-648-2361	3902, 3933, 3903

*NOTE: Contact LCD manufacturer for full product listing/specifications.

Decimal Point and Annunciator Drive

The test pin is connected to the internally-generated digital logic supply ground through a 500Ω resistor. The test pin may be used as the negative supply for external CMOS gate segment drivers. LCD annunciators for decimal points, low battery indication, or function indication may be added without adding an additional supply. No more than 1 mA should be supplied by the test pin. The test pin potential is approximately 5V below V^+ .

LOW POWER, 3-1/2 DIGIT ANALOG-TO-DIGITAL CONVERTERS

1

**TC7136
TC7136A**

Ratiometric Resistance Measurements

The TC7136A's true differential input and differential reference make ratiometric readings possible. In ratiometric operation, an unknown resistance is measured with respect to a known standard resistance. No accurately-defined reference voltage is needed.

The unknown resistance is put in series with a known standard and a current passed through the pair. The voltage developed across the unknown is applied to the input and the voltage across the known resistor applied to the reference input. If the unknown equals the standard, the display will read 1000. The displayed reading can be determined from the following expression:

$$\text{Displayed reading} = \frac{R_{\text{UNKNOWN}}}{R_{\text{STANDARD}}} \times 1000.$$

The display will overrange for $R_{\text{UNKNOWN}} \geq 2 \times R_{\text{STANDARD}}$.

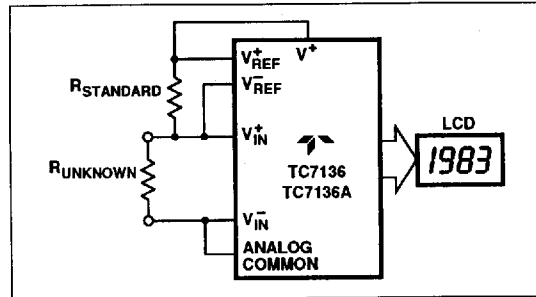

Figure 12 Low Parts Count Ratiometric Resistance Measurement

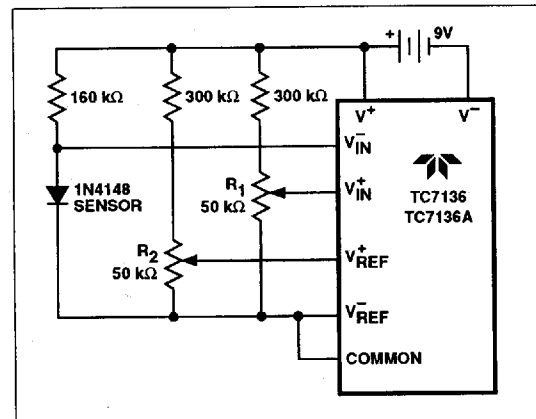

Figure 13 Temperature Sensor

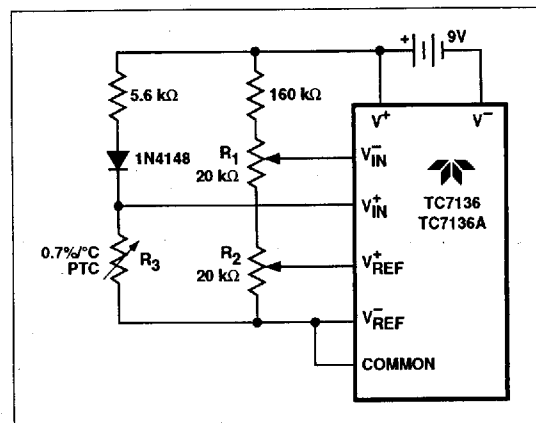

Figure 14 Positive Temperature Coefficient Resistor Temperature Sensor

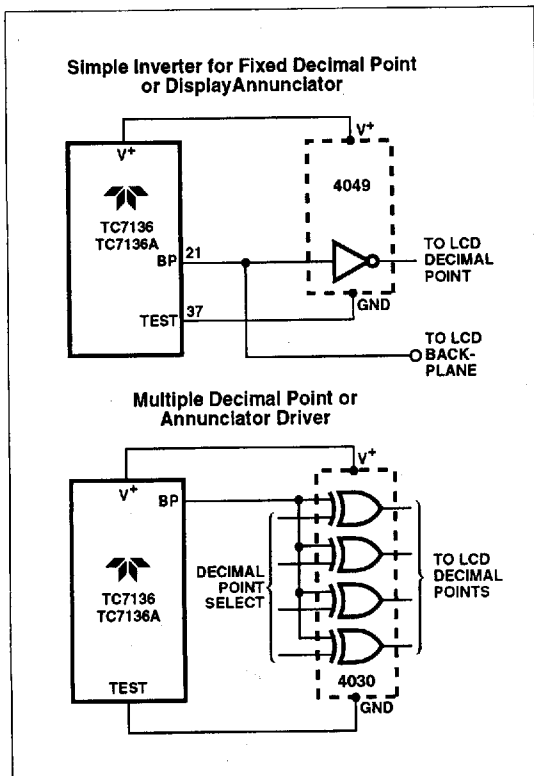

Figure 11 Decimal Point and Annunciator Drives