

8-Bit Transceiver
Features

- Function and pinout compatible with FCT and F logic
- 25Ω output series resistors to reduce transmission line reflection noise
- FCT-C speed at 4.1 ns max. (Com'l)
FCT-A speed at 4.6 ns max. (Com'l)
- Edge-rate control circuitry for significantly improved noise characteristics
- Power-off disable feature
- Fully compatible with TTL input and output logic levels
- ESD > 2000V

- Sink current **12 mA (Com'l),
12 mA (Mil)**
- Source current **15 mA (Com'l),
12 mA (Mil)**

Three-state outputs
Functional Description

The FCT2245T contains eight non-inverting, bidirectional buffers with three-state outputs intended for bus oriented applications. On-chip termination resistors have been added to the outputs to reduce system noise caused by reflections. For this reason, the FCT2245T can be used in an existing design to replace the FCT245T. The FCT2245T current sink-

ing capability is 12 mA at the A and B ports.

The Transmit/Receive (T/R) input determines the direction of data flow through the bidirectional transceiver. Transmit (Active HIGH) enables data from A ports to B ports; receive (Active LOW) enables data from B ports to A ports. The output enable (OE) input, when HIGH, disables both the A and B ports by putting them in a High Z condition.

The outputs are designed with a power-off disable feature to allow for live insertion of boards.

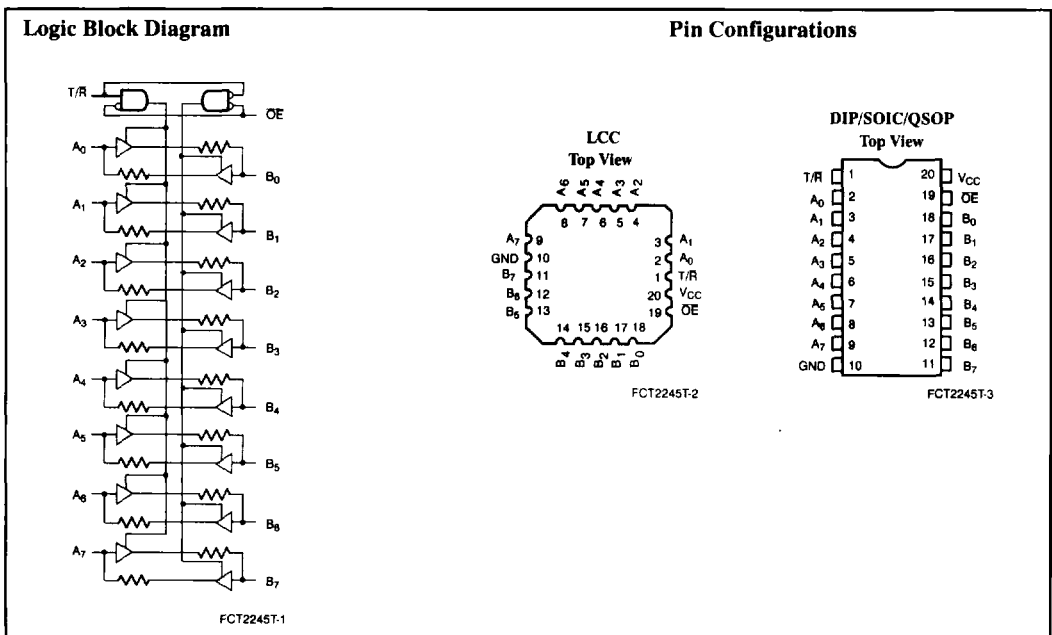
Function Table ⁽¹⁾

Inputs		Output
OE	T/R	
L	L	Bus B Data to Bus A
L	H	Bus A Data to Bus B
H	X	High Z State

Note:

1. H = HIGH Voltage Level. L = LOW Voltage Level. X = Don't Care.

Maximum Ratings^[2,3]

(Above which the useful life may be impaired. For user guidelines, not tested.)

Storage Temperature	−65°C to +150°C
Ambient Temperature with Power Applied	−65°C to +135°C
Supply Voltage to Ground Potential	−0.5V to +7.0V
DC Input Voltage	−0.5V to +7.0V
DC Output Voltage	−0.5V to +7.0V
DC Output Current (Maximum Sink Current/Pin)	120 mA
Power Dissipation	0.5W

Static Discharge Voltage >2001V
(per MIL-STD-883, Method 3015)

Operating Range

Range	Range	Ambient Temperature	V _{CC}
Commercial	CT, DT	0°C to +70°C	5V ± 5%
Commercial	T, AT	−40°C to +85°C	5V ± 5%
Military ^[4]	All	−55°C to +125°C	5V ± 10%

Electrical Characteristics Over the Operating Range

Parameter	Description	Test Conditions		Min.	Typ. ^[5]	Max.	Unit
V _{OH}	Output HIGH Voltage	V _{CC} =Min., I _{OH} =−15 mA	Com'l	2.4	3.3		V
		V _{CC} =Min., I _{OH} =−12 mA	Mil	2.4	3.3		V
V _{OL}	Output LOW Voltage	V _{CC} =Min., I _{OL} =12 mA	Com'l		0.3	0.55	V
		V _{CC} =Min., I _{OL} =12 mA	Mil		0.3	0.55	V
R _{OUT}	Output Resistance	V _{CC} =Min., I _{OL} =12 mA	Com'l	20	25	40	Ω
		V _{CC} =Min., I _{OL} =12 mA	Mil		25		Ω
V _{IH}	Input HIGH Voltage			2.0			V
V _{IL}	Input LOW Voltage					0.8	V
V _H	Hysteresis ^[6]	All inputs			0.2		V
V _{IK}	Input Clamp Diode Voltage	V _{CC} =Min., I _{IN} =−18 mA			−0.7	−1.2	V
I _I	Input HIGH Current	V _{CC} =Max., V _{IN} =V _{CC}				5	μA
I _{IH}	Input HIGH Current	V _{CC} =Max., V _{IN} =2.7V				±1	μA
I _{IL}	Input LOW Current	V _{CC} =Max., V _{IN} =0.5V				±1	μA
I _{OS}	Output Short Circuit Current ^[7]	V _{CC} =Max., V _{OUT} =0.0V		−60	−120	−225	mA
I _{OFF}	Power-Off Disable	V _{CC} =0V, V _{OUT} =4.5V				±1	μA

Capacitance^[6]

Parameter	Description	Test Conditions	Typ. ^[5]	Max.	Unit
C _{IN}	Input Capacitance		5	10	pF
C _{OUT}	Output Capacitance		9	12	pF

Notes:

- Unless otherwise noted, these limits are over the operating free-air temperature range.
- Unused inputs must always be connected to an appropriate logic voltage level, preferably either V_{CC} or ground.
- T_A is the "instant on" case temperature.
- Typical values are at V_{CC}=5.0V, T_A=+25°C ambient.
- This parameter is guaranteed but not tested.
- Not more than one output should be shorted at a time. Duration of short should not exceed one second. The use of high-speed test apparatus and/or sample and hold techniques are preferable in order to minimize internal chip heating and more accurately reflect operational values. Otherwise prolonged shorting of a high output may raise the chip temperature well above normal and thereby cause invalid readings in other parametric tests. In any sequence of parameter tests, I_{OS} tests should be performed last.



Power Supply Characteristics

Parameter	Description	Test Conditions	Typ. ^[5]	Max.	Unit
I _{CC}	Quiescent Power Supply Current	V _{CC} =Max., V _{IN} ≤0.2V, V _{IN} ≥V _{CC} -0.2V	0.1	0.2	mA
ΔI _{CC}	Quiescent Power Supply Current (TTL inputs)	V _{CC} =Max., V _{IN} =3.4V ^[8] f _I =0, Outputs Open	0.5	2.0	mA
I _{CCD}	Dynamic Power Supply Current ^[9]	V _{CC} =Max., One Input Toggling, 50% Duty Cycle, Outputs Open, T/R=OE=GND, V _{IN} ≤0.2V or V _{IN} ≥V _{CC} -0.2V	0.06	0.12	mA/ MHz
I _C	Total Power Supply Current ^[10]	V _{CC} =Max., 50% Duty Cycle, Outputs Open, One Bit Toggling at f _I =10 MHz, T/R=OE=GND, V _{IN} ≤0.2V or V _{IN} ≥V _{CC} -0.2V	0.7	1.4	mA
		V _{CC} =Max., 50% Duty Cycle, Outputs Open, One Bit Toggling at f _I =10 MHz, T/R=OE=GND, V _{IN} =3.4V or V _{IN} =GND	1.0	2.4	mA
		V _{CC} =Max., 50% Duty Cycle, Outputs Open, Eight Bits Toggling at f _I =2.5 MHz, T/R=OE=GND, V _{IN} ≤0.2V or V _{IN} ≥V _{CC} -0.2V	1.3	2.6 ^[11]	mA
		V _{CC} =Max., 50% Duty Cycle, Outputs Open, Eight Bits Toggling at f _I =2.5 MHz, T/R=OE=GND, V _{IN} =3.4V or V _{IN} =GND	3.3	10.6 ^[11]	mA

Notes:

8. Per TTL driven input (V_{IN}=3.4V); all other inputs at V_{CC} or GND.

9. This parameter is not directly testable, but is derived for use in Total Power Supply calculations.

10. I_C = I_{QUIESCENT} + I_{INPUTS} + I_{DYNAMIC}

I_C = I_{CC} + ΔI_{CC}D_HN_T + I_{CCD}(f₀/2 + f_IN_I)

I_{CC} = Quiescent Current with CMOS input levels

ΔI_{CC} = Power Supply Current for a TTL HIGH input (V_{IN}=3.4V)

D_H = Duty Cycle for TTL inputs HIGH

N_T = Number of TTL inputs at D_H

I_{CCD} = Dynamic Current caused by an input transition pair (HLH or LHL)

f₀ = Clock frequency for registered devices, otherwise zero

f_I = Input signal frequency

N_I = Number of inputs changing at f_I

All currents are in milliamps and all frequencies are in megahertz.

11. Values for these conditions are examples of the I_{CC} formula. These limits are guaranteed but not tested.

Switching Characteristics Over the Operating Range

Parameter	Description	FCT2245T				FCT2245AT				Unit	Fig. No. ^[3]
		Military		Commercial		Military		Commercial			
		Min. ^[12]	Max.	Min. ^[12]	Max.	Min. ^[12]	Max.	Min. ^[12]	Max.		
t _{PLH} t _{PHL}	Propagation Delay A _n to B _n or B _n to A _n	1.5	7.5	1.5	7.0	1.5	4.9	1.5	4.6	ns	1, 3
t _{PZH} t _{PZL}	Output Enable Time	1.5	10.0	1.5	9.5	1.5	6.5	1.5	6.2	ns	1, 7, 8
t _{PHZ} t _{PLZ}	Output Disable Time	1.5	10.0	1.5	7.5	1.5	6.0	1.5	5.0	ns	1, 7, 8

Switching Characteristics Over the Operating Range (continued)

Parameter	Description	FCT2245CT		FCT2245DT		Unit	Fig. No. ^[3]
		Commercial		Commercial			
		Min. ^[12]	Max.	Min. ^[12]	Max.		
t _{PLH} t _{PHL}	Propagation Delay A _n to B _n or B _n to A _n	1.5	4.1	1.5	3.8	ns	1, 3
t _{PZH} t _{PZL}	Output Enable Time	1.5	5.8	1.5	5.0	ns	1, 7, 8
t _{PHZ} t _{PLZ}	Output Disable Time	1.5	4.5	1.5	4.3	ns	1, 7, 8

Ordering Information—FCT2245T

Speed (ns)	Ordering Code	Package Name	Package Type	Operating Range
3.8	CY74FCT2245DTQC	Q5	20-Lead (150-Mil) QSOP	Commercial
	CY74FCT2245DTSOC	S5	20-Lead (300-Mil) Molded SOIC	
4.1	CY74FCT2245CTPC	P5	20-Lead (300-Mil) Molded DIP	Commercial
	CY74FCT2245CTQC	Q5	20-Lead (150-Mil) QSOP	
	CY74FCT2245CTSOC	S5	20-Lead (300-Mil) Molded SOIC	
4.6	CY74FCT2245ATPC	P5	20-Lead (300-Mil) Molded DIP	Commercial
	CY74FCT2245ATQC	Q5	20-Lead (150-Mil) QSOP	
	CY74FCT2245ATSOC	S5	20-Lead (300-Mil) Molded SOIC	
4.9	CY54FCT2245ATDMB	D6	20-Lead (300-Mil) CerDIP	Military
	CY54FCT2245ATLMB	L61	20-Pin Square Leadless Chip Carrier	
7.0	CY54FCT2245TDMB	D6	20-Lead (300-Mil) CerDIP	Military
	CY54FCT2245TLMB	L61	20-Pin Square Leadless Chip Carrier	
7.5	CY74FCT2245TPC	P5	20-Lead (300-Mil) Molded DIP	Commercial
	CY74FCT2245TQC	Q5	20-Lead (150-Mil) QSOP	
	CY74FCT2245TSOC	S5	20-Lead (300-Mil) Molded SOIC	

Shaded areas contain preliminary information.

Notes:

12. Minimum limits are guaranteed but not tested on Propagation Delays.
13. See "Parameter Measurement Information" in the General Information section.

Document #: 38-00349