Fiber Optic "Light to Logic"™ Receiver

Technical Data

RCV5201

Features

- **Light to Logic 20-pin DIP Receiver Offers ECL Compatibility**
- **-36 dBm at 155 Mbit/s
-40 dBm at 52 Mbit/s**
- **Single +5 Volt Supply**
- **GaAs IC Preamplicifier for High Performance**
- **Maximum Optical Input Power >-7 dBm**
- **SONET/SDH Compliant**

Applications

- **Telecommunications Networks**
- **SONET and SDH Compatible**
- **Local Area and Metropolitan Area Networks**
- **Military Communications and Control Systems**
- **Digital Cable TV Networks**

Description

The RCV5201 receivers provide optical signal conversion and processing. Each receiver contains an InGaAs PIN photodiode and high sensitivity, wide dynamic range, transimpedance amplifier, capacitively coupled to limiting amplifier stages with PECL output drivers. Also provided is a loss of signal alarm.

The planar PIN photodiode operates throughout the 1200 nm to 1600 nm wavelength band. A GaAs IC wide dynamic range transimpedance amplifier optimized for either 52 Mbaud or 155 Mbaud operation provides the low noise front end gain.

A low pass filter maximizes the signal to noise ratio while minimizing intersymbol interference. The interface amplifier provides signal conversion and buffering for the PECL complementary data outputs. A complementary PECL alarm output is also provided.



The receivers operate from +5 volt and -5.2 volt or +5 volt and Ground power supplies. A 50/125 micron multimode fiber pigtail is included, assuring compatibility with multimode and single mode fiber optic systems.

Connection Diagram

Top View

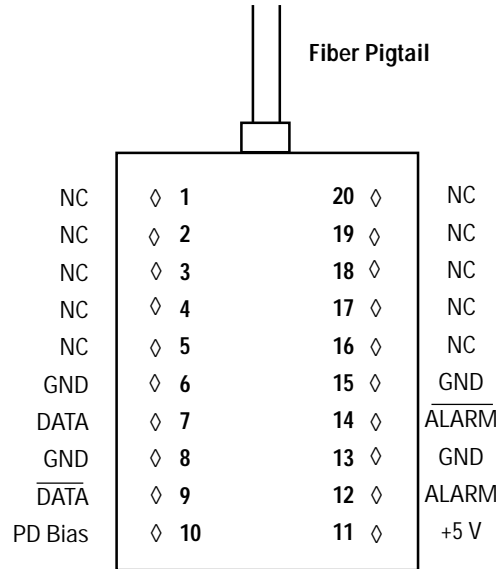

Pin Descriptions

Pin 1, 2, 3, 4, 5, 16, 17, 18, 19, 20 NC:

These pins are not connected and should be left open circuit on the application PCB.

Pin 6, 8, 13, 15 GND:

These pins should be connected to the circuit ground.

Pin 7, 9, Data, $\overline{\text{Data}}$:

These pins provide complimentary differential PECL DATA and $\overline{\text{DATA}}$ outputs. The RCV5201 DATA output is non inverting, an optical pulse causes the DATA output to go to the PECL logic high state (+4 Volt nominal).

Pin 12, 14 ALARM, $\overline{\text{ALARM}}$:

These pins provide complimentary differential ALARM and $\overline{\text{ALARM}}$ outputs. This is the low light alarm. ALARM goes to a logic low (3.3 Volt nominal) state when the optical power drops below the threshold level (insufficient optical power).

The optical power must increase to a higher level than the level where the alarm went low before ALARM will return high. This difference is the alarm hysteresis.

Pin 10, PD Bias:

This pin must be connected to any voltage from 0 Volt (GND) to 5 Volt. This provides the photodiode bias and the current drawn is directly proportional to the average received photocurrent $I = \text{Responsivity} \times \text{Mean Power}$. The responsivity will be between 0.7 A/W and 1.0 A/W.

Functional Description

Design

The RCV5201 receiver contains an InGaAsP photodetector, transimpedance amplifier and interface amplifier circuit. It is designed with a multimode fiber pigtail to allow maximum flexibility in connector options.

The interface amplifier is capacitively coupled to the preamplifier circuit with a time constant of approximately 0.1 ms.

Terminating the Outputs

The data outputs of the RCV5201 are PECL compatible. Care should be taken to match termination impedances to the interconnect to minimize reflection effects. Both serial data outputs (DATA and $\overline{\text{DATA}}$) should be terminated identically, even if only one output is used, in order to balance the drive currents drawn from the RCV5201. This will lower the power supply noise generated by the RCV5201 and improve performance at low optical input power levels.

Power Supplies

The RCV5201 will operate to specifications with a single +5 Volt power supply (Pin 10 Grounded). The -5 Volt PIN bias is provided to maintain functional compatibility with second sources.

Circuit Layout

The RCV5201 uses very high bandwidth circuitry to achieve its high level of performance. Care must be taken to ensure stable operation. The use of ground planes and transmission line interconnects is required. The use of a standard evaluation board is highly recommended for those users who are not familiar with these techniques.

Signal traces should conform to ECL design rules to prevent reflections and ringing from degrading performance. Useful guidelines are contained in ECL manufacturer design manuals.

Manufacturing

The fiber pigtail on the device requires normal fiber handling considerations. Care should be taken to avoid tight bends as well as excessive tension on the fiber pigtail.

The allowable temperature range for the RCV5201 is limited by the material used in the pigtail. Exposure to temperatures over 85°C is not recommended. Low profile sockets or hand soldering is recommended for this part.

Figure 1 - Block Diagram

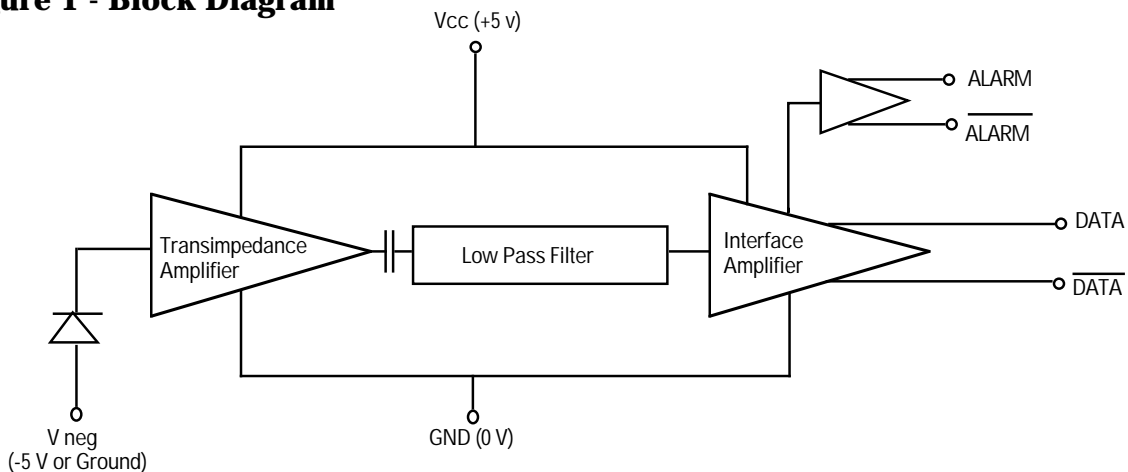

Performance Specifications

Absolute Limiting Ratings

Parameter	Symbol	Minimum	Maximum	Units	Note
Supply Voltage	V _{cc}	-0.5	+5.5	V	1
Supply Voltage	V _{neg}	-10	+0.5	V	-

Environmental Parameters

Parameter	Symbol	Minimum	Maximum	Units	Note
Operating Temperature	-	-40	+85	°C	-
Storage Temperature	-	-40	+85	°C	-
Humidity	-	-	85	%RH	-

Electrical Parameters (-40°C to +85°C)

Parameter	Symbol	Minimum	Maximum	Units	Note
Supply Voltage	V _{cc}	4.75	5.3	V	-
Supply Voltage	V _{neg}	0	-6.0	V	-
V _{cc} Supply Current	-	-	100	mA	4
V _{neg} Supply Current	-	-	1.0	mA	-
DATA Output Level (high)	-	3.9	4.15	V	2, 3
DATA Output Level (low)	-	3.1	3.5	V	2, 3
ALARM Output Level (high)	V _{off}	3.9	4.15	V	2, 3
ALARM Output Level (low)	V _{on}	3.1	3.5	V	2, 3

Notes:

1. V_{cc} of -0.5 volt and V_{neg} of +0.5 volt may not be applied simultaneously.
2. Output terminated to (V_{cc} - 2) with 50 Ω load or equivalent.
3. Output voltages are for V_{cc} = 5.0 volt.
4. Outputs not loaded.

Optical Parameters (-40°C to +85°C)

Parameter	Symbol	Minimum	Maximum	Units	Note
Wavelength	-	1200	1600	nm	-
Receiver Sensitivity					-
52 Mb	-	-	-40	dBm	1
155 Mb	-	-	-36	dBm	1
Maximum Input Power	-	-7.0	-	dBm	-
Alarm ON					-
52 Mb	-	-48	-40	dBm	-
155 Mb	-	-44	-36	dBm	-
Hysteresis	-	0.5	4	dB	-
Alarm Response Time	-	-	600	μS	-
Reliability Target	-	-	2000	FIT	-

Notes:

1. At a BER of 1×10^{-10} , 2^{23-1} PRBS pattern NRZ data at the line rate with 10:1 extinction ratio.

Fiber Pigtail	Typical	Units
Fiber Core	50	microns
Fiber Outer Diameter	125	microns
Fiber Plastic Diameter	900	microns

Drawing Dimensions

DIM	MIN	NOM	MAX
A	-	33.02	33.2
B	-	-	40.75
C	16.0	16.13	16.3
D	-	-	9.27
E	2.6	2.8	2.95
F	-	2.54	-
ØG	0.46	0.5	0.53
H	3.1	-	3.5
J	-	4.57	-
K	10	10.16	10.3
L	400	-	1000

All dimensions in mm

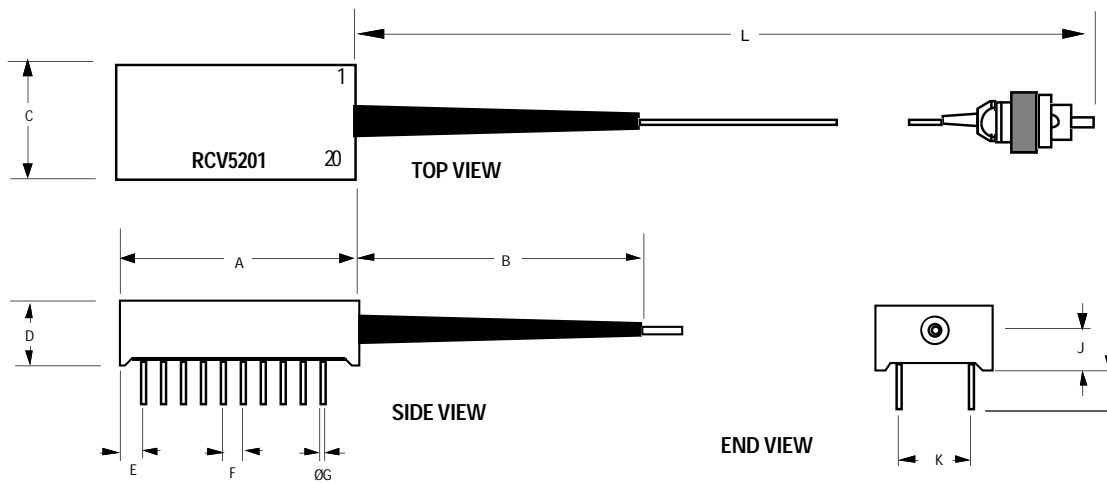

Ordering Information

Please order part number RCV5201-XXX-FP

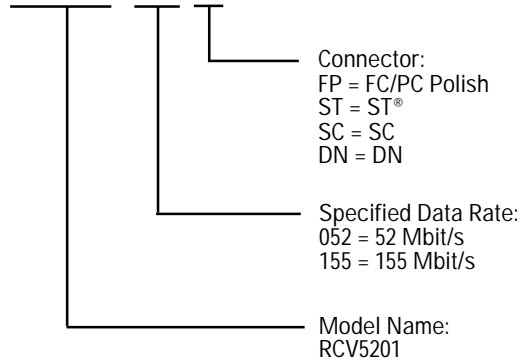

Allowable part numbers

RCV5201-052-FP
RCV5201-052-ST
RCV5201-052-SC
RCV5201-052-DN
RCV5201-155-FP
RCV5201-155-ST
RCV5201-155-SC
RCV5201-155-DN

Handling Precautions

1. The RCV5201 can be damaged by current surges or overvoltage. Power supply transient precautions should be taken.
2. Normal handling precautions for electrostatic sensitive devices should be taken.



For more information:

*United States:

*Europe:

Far East/Australasia: (65) 290-6305

Canada: (416) 206-4725

Japan: (81) 3 3331 6111

*Call your local HP sales office listed in your telephone directory and ask for a Components representative.

Data subject to change
Copyright ©1995 Hewlett-Packard Co.

Printed in USA 5963-3563E (3/95)