

Compact, Small Package 1A Power-Distribution Switches

Features

- High Side N-MOSFET with Internal Charge Pump
- 1A Continuous Current
- Built-in Soft-Start
- Wide Supply Voltage Range
- Current-Limit and Short-Circuit Protections
- Input Voltage Under Voltage Lockout Protection
- Reverse Current Blocking when Switch Disabled
- Output OVP Protection
- Reverse Current-Limit Protection
- Output Discharge
- Over-Temperature Protection
- UL Approved-File No. E328191
- Nemko IEC/EN 60950-1 CB Scheme Certified, No.79342
- TUV IEC/EN 60950-1 Certified, No.44 780 14 406748-004
- Lead Free and Green Devices Available (RoHS Compliant)

Applications

- HDMI Port Protection Switches
- Bluetooth Protection Switches
- High-side Power Protection Switches

Simplified Application Circuit

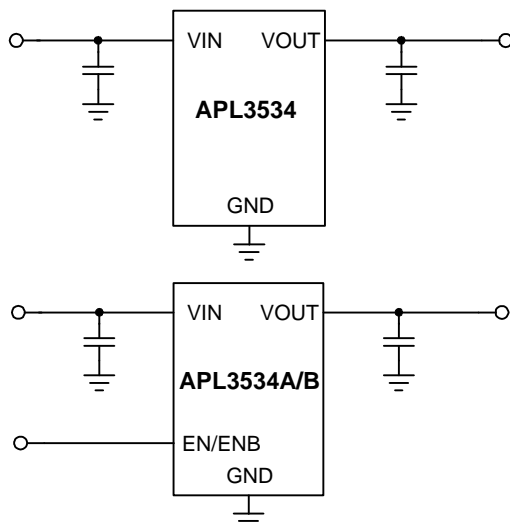

General Description

The APL3534/A/B is a power-distribution switch with current-limiting function and output OVP protections that can deliver current up to 1A. The device incorporates a 110mΩ N-channel MOSFET power switch.

The device integrates some protection features, including current-limit protection, output over-voltage protection, over-temperature protection and UVLO. The current-limit protection can protect down-stream devices from catastrophic failure by limiting the output current at current-limit threshold during over-load or short-circuit events. The output over-voltage protection can prevent current flowing from VOUT to VIN when an abnormally high voltage exists in VOUT. The over-temperature protection function shuts down the N-channel MOSFET power switch when the junction temperature rises beyond 140°C and will automatically turns on the power switch when the temperature drops by 20°C. The UVLO function keeps the power switch in off state until there is a valid input voltage present.

The device is available in lead free SOT-23-3 and SOT-23-5 packages.

Pin Configuration

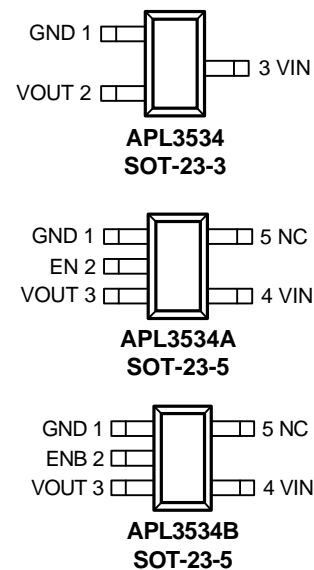

ANPEC reserves the right to make changes to improve reliability or manufacturability without notice, and advise customers to obtain the latest version of relevant information to verify before placing orders.

Ordering and Marking Information

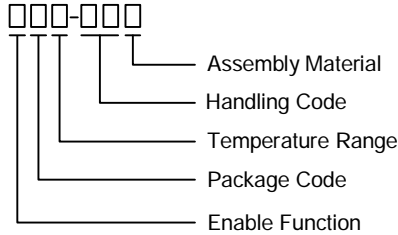
APL3534		Enable Function Blank : No Enable Function A : Active High B : Active Low Package Code A : SOT-23-3 B : SOT-23-5 Operating Ambient Temperature Range I : -40 to 85 °C Handling Code TR : Tape & Reel Assembly Material G : Halogen and Lead Free Device
APL3534 A:	L34X	X - Date Code
APL3534A B:	L4AX	X - Date Code
APL3534B B:	L4BX	X - Date Code

Note: ANPEC lead-free products contain molding compounds/die attach materials and 100% matte tin plate termination finish; which are fully compliant with RoHS. ANPEC lead-free products meet or exceed the lead-free requirements of IPC/JEDEC J-STD-020D for MSL classification at lead-free peak reflow temperature. ANPEC defines "Green" to mean lead-free (RoHS compliant) and halogen free (Br or Cl does not exceed 900ppm by weight in homogeneous material and total of Br and Cl does not exceed 1500ppm by weight).

Absolute Maximum Ratings (Note 1)

Symbol	Parameter	Rating	Unit
V _{IN}	VIN to GND Voltage	-0.3 ~ 6.5	V
V _{OUT}	VOUT to GND Voltage	-0.3 ~ 6.5	V
V _{EN} , V _{ENB}	EN, ENB to GND Voltage	-0.3 ~ 6.5	V
T _J	Maximum Junction Temperature	-40 ~ 150	°C
T _{STG}	Storage Temperature	-65 ~ 150	°C
T _{SDR}	Maximum Lead Soldering Temperature (10 Seconds)	260	°C

Note1: Stresses beyond those listed under "absolute maximum ratings" may cause permanent damage to the device. These are stress ratings only and functional operation of the device at these or any other conditions beyond those indicated under "recommended operating conditions" is not implied. Exposure to absolute maximum rating conditions for extended periods may affect device reliability.

Thermal Characteristics (Note 2)

Symbol	Parameter	Typical Value	Unit
θ _{JA}	Junction-to-Ambient Resistance in free air (SOT-23-3, SOT-23-5)	260	°C/W

Note 2: θ_{JA} is measured with the component mounted on a high effective thermal conductivity test board in free air.

Recommended Operating Conditions (Note 3)

Symbol	Parameter	Range	Unit
V _{IN}	VIN Input Voltage	2.7~ 5.4	V
I _{OUT}	OUT Output Current	0 ~ 1	A
T _A	Ambient Temperature	-40 ~ 85	°C
T _J	Junction Temperature	-40 ~ 125	°C

Note 3: Refer to the typical application circuit.

Electrical Characteristics

V_{IN}=5V, V_{EN}=5V or V_{ENB}=0V and T_A=25°C (unless otherwise noted).

Symbol	Parameter	Test Conditions	APL3534/A/B			Unit
			Min.	Typ.	Max.	
UNDER-VOLTAGE LOCKOUT						
	VIN UVLO Threshold Voltage	V _{IN} rising	2.35	2.5	2.65	V
	VIN UVLO Hysteresis		-	0.1	-	V
SUPPLY CURRENT						
I _{VIN}	VIN Supply Current	No load, V _{EN} = High (or V _{ENB} = Low)	-	100	150	μA
I _{SD}	VIN Shutdown Current	No load, V _{EN} = Low (or V _{ENB} = High)	-	-	1	μA
	OUT Leakage Current	V _{OUT} tied to ground, V _{EN} =Low (or V _{ENB} = High)	-	-	1	μA
	OUT Input Current	V _{OUT} =5V, V _{IN} = 0V, no matter V _{EN} = Low or High	-	-	1	μA
POWER SWITCH						
R _{DS(ON)}	Power Switch On Resistance	V _{IN} =5V, I _{OUT} =1A, T _J =25°C	-	110	140	mΩ
		V _{IN} =5V, I _{OUT} =1A, T _J =-40~125°C	-	-	175	mΩ
		V _{IN} =3.3V, I _{OUT} =1A, T _J =25°C	-	120	155	mΩ
		V _{IN} =3.3V, I _{OUT} =1A, T _J =-40~125°C	-	-	195	mΩ
CURRENT-LIMIT PROTECTIONS						
I _{LIM}	Current-Limit Threshold	T _J =25°C,	1.3	1.6	1.9	A
		T _J =-40~125°C	1.05	-	-	A
I _{SHORT}	Short-Circuit Output Current	V _{OUT} <1.2V (This function is disabled during soft start interval)	0.3	0.6	1	A
OUTPUT OVER-VOLTAGE PROTECTS						
I _{RV}	Reverse Current Blocking Threshold	V _{OUT} - V _{IN} =1V, T _J =25°C	0.3	0.5	0.7	A
t _{RVDEG}	Reverse Current Blocking Deglitch Time	Guaranteed by Design	-	0.7	-	ms
V _{OVP}	Output OVP Threshold		5.5	5.75	6	V
T _{OVD}	Output OVP Delay Time		-	20	-	μs
SOFT-START CONTROL PIN						
t _{SS}	Soft-Start Time	V _{IN} =5V, V _{OUT} =10% to 90%	1	2.5	4	ms

Electrical Characteristics (Cont.)

$V_{IN}=5V$, $V_{EN}=5V$ or $V_{ENB}=0V$ and $T_A=25^{\circ}C$ (unless otherwise noted).

Symbol	Parameter	Test Conditions	APL3534/A/B			Unit
			Min.	Typ.	Max.	
OUTPUT DISCHARGE AND ENABLE						
	VOUT Discharge Resistance	$V_{IN}=5V$, $V_{EN}=\text{Low}$ (or $V_{ENB}=\text{High}$), $V_{OUT}=1V$	-	40	-	Ω
V_{EN}, V_{ENB}	Input Logic High		2	-	-	V
	Input Logic Low		-	-	0.8	V
	EN, ENB Input Current	$V_{EN}=5V$ or $V_{ENB}=5V$	-	-	1	μA
	EN, ENB Leakage	$V_{EN}=0V$ or $V_{ENB}=0V$	-	-	1	μA
OUTPUT TEMPERATURE PROTECTION (OTP)						
T_{OTP}	Over-Temperature Threshold	T_J rising	-	140	-	$^{\circ}C$
	Over-Temperature Hysteresis		-	20	-	$^{\circ}C$

Typical Operating Characteristics

UVLO Threshold Voltage vs. Junction Temperature

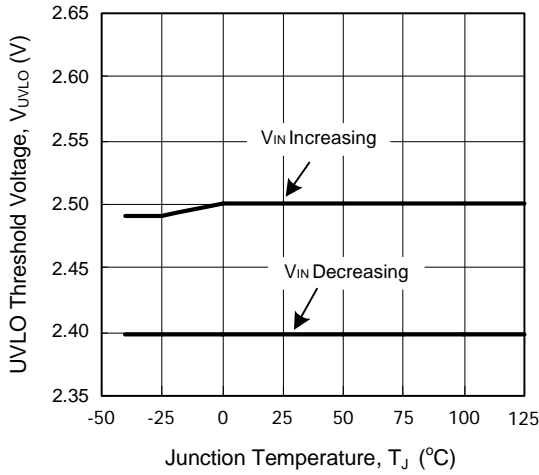

Supply Current vs. Junction Temperature

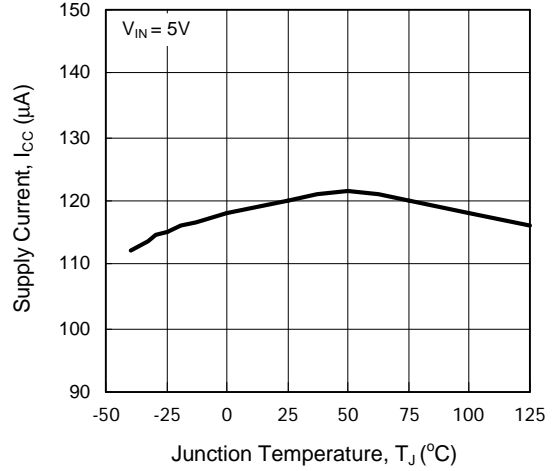

Switch On Resistance vs. Junction Temperature

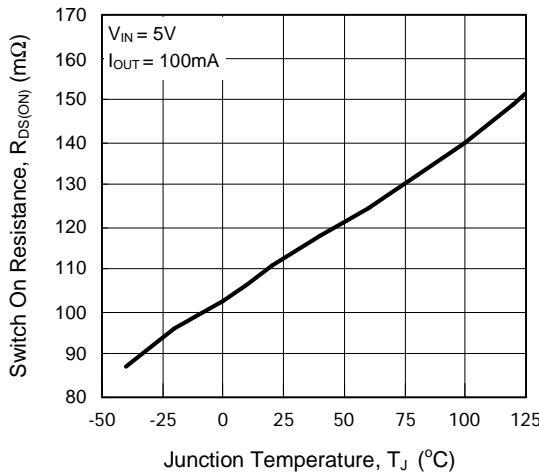

Switch On Resistance vs. Input Voltage

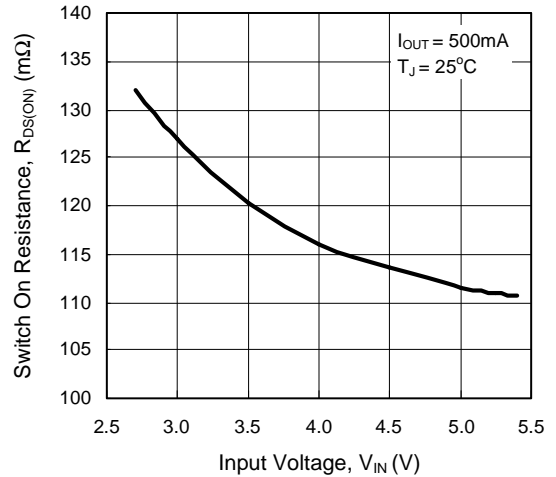

Current Limit Threshold vs. Junction Temperature

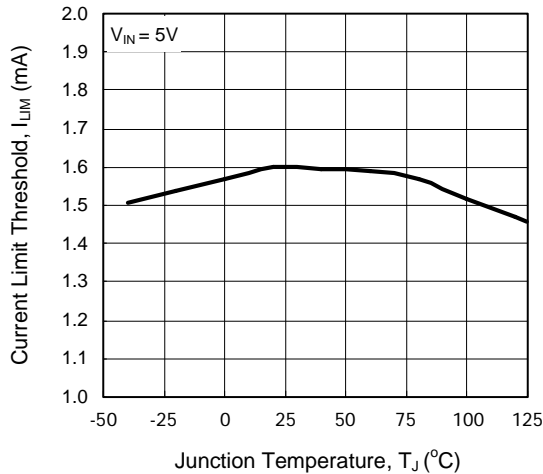

Short-Circuit Output Current vs. Junction Temperature

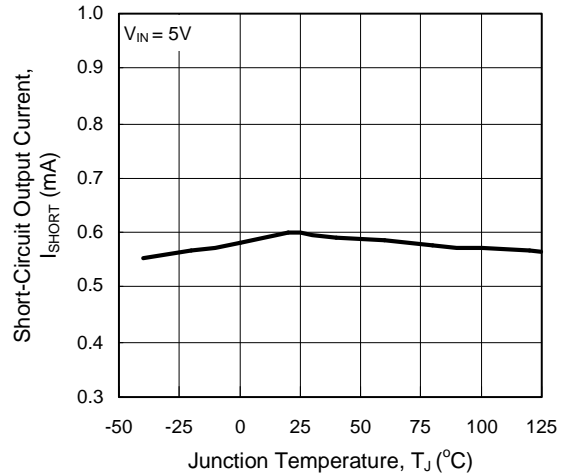

Typical Operating Characteristics

Current-Limit Response vs. Output Peak Current

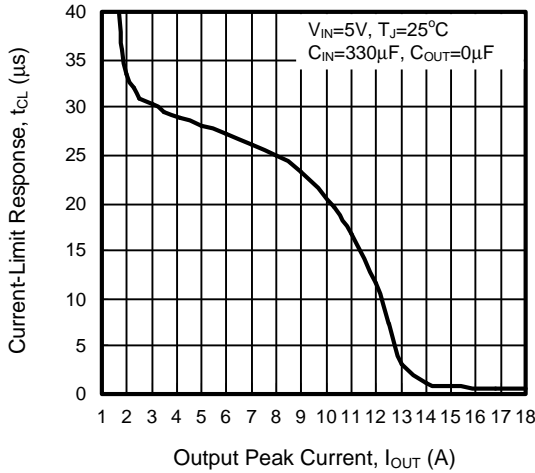

Switch On Resistance vs. Output Current

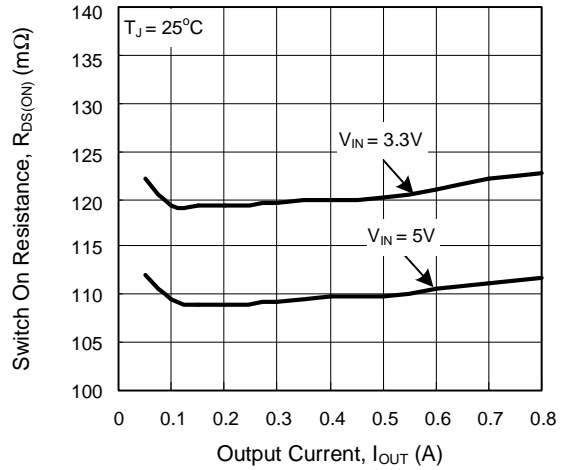

Output OVP Threshold vs. Junction Temperature

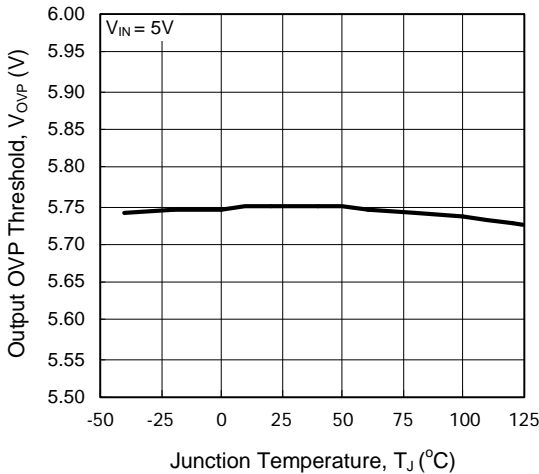

Reverse Current Blocking Threshold vs. Junction Temperature

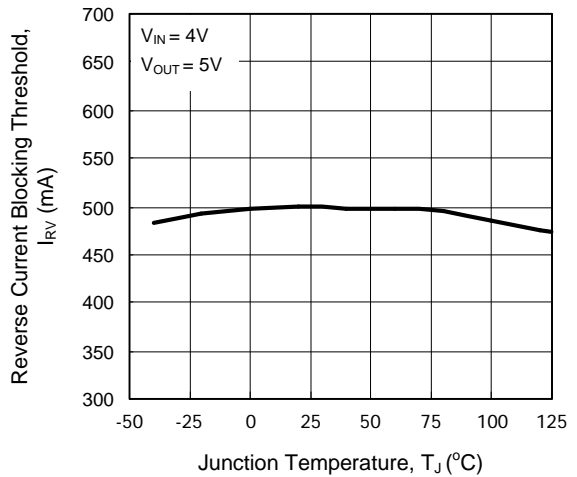

Reverse Current Blocking Threshold vs. Output Voltage

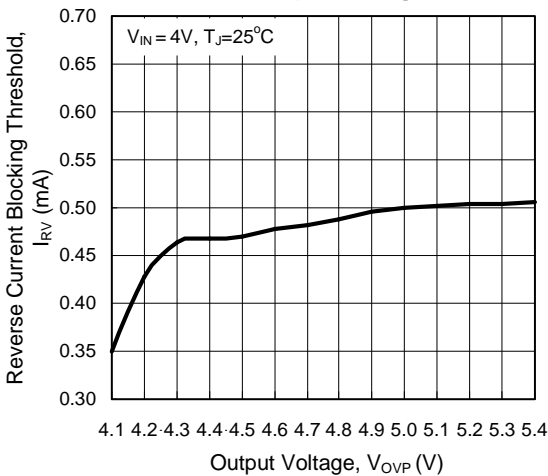

EN pin Threshold Voltage vs. Input Voltage

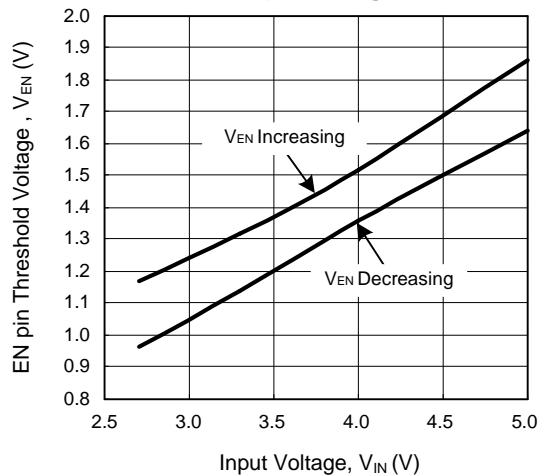

Operating Waveforms

Refer to the typical application circuit. The test condition is $V_{IN}=5V$, $T_A=25^{\circ}C$ unless otherwise specified.

Power On

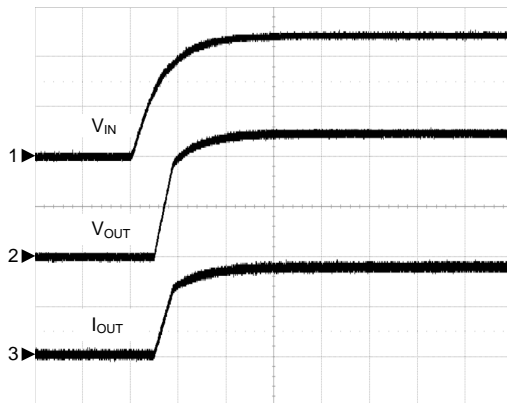

$C_{IN}=0.1\mu F$, $C_{OUT}=0.1\mu F$, $R_{OUT}=5\Omega$
 CH1: V_{IN} , 2V/Div, DC
 CH2: V_{OUT} , 2V/Div, DC
 CH3: I_{OUT} , 0.5A/Div, DC
 TIME: 5ms/Div

Power Off

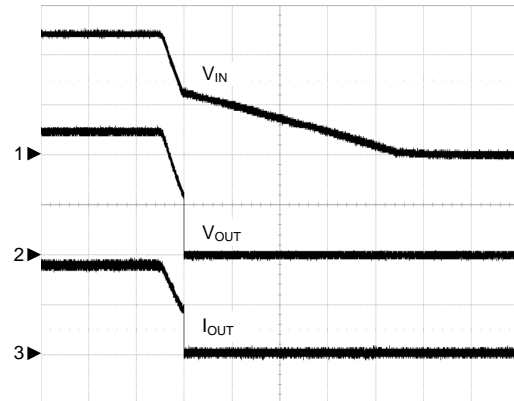

$C_{IN}=0.1\mu F$, $C_{OUT}=0.1\mu F$, $R_{OUT}=5\Omega$
 CH1: V_{IN} , 2V/Div, DC
 CH2: V_{OUT} , 2V/Div, DC
 CH3: I_{OUT} , 0.5A/Div, DC
 TIME: 5ms/Div

Short Circuit Response

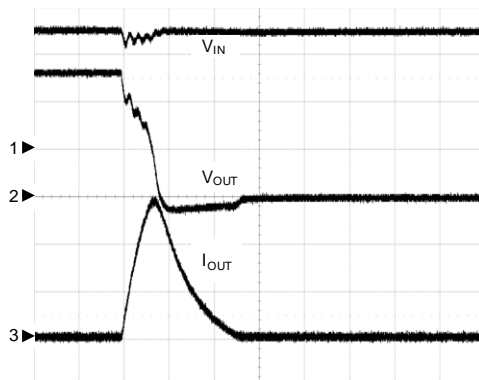

$C_{IN}=330\mu F$, $C_{OUT}=0\mu F$, $R_{OUT}=\text{Open} \rightarrow 0\Omega$
 CH1: V_{IN} , 2V/Div, DC
 CH2: V_{OUT} , 2V/Div, DC
 CH3: I_{OUT} , 5A/Div, DC
 TIME: 1 μs /Div

Over-Current Protection

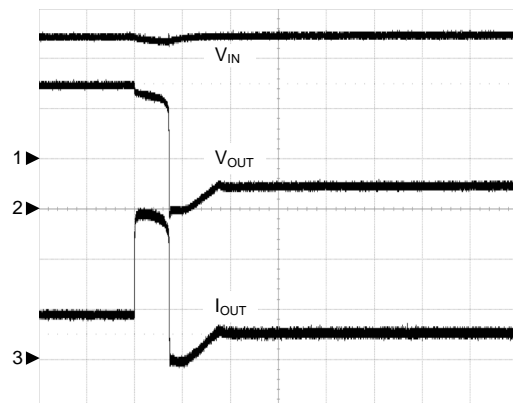

$C_{IN}=330\mu F$, $C_{OUT}=0.1\mu F$, $I_{OUT}=5\Omega$ to 2Ω
 CH1: V_{IN} , 2V/Div, DC
 CH2: V_{OUT} , 2V/Div, DC
 CH3: I_{OUT} , 1A/Div, DC
 TIME: 50 μs /Div

Operating Waveforms

Refer to the typical application circuit. The test condition is $V_{IN}=5V$, $T_A=25^{\circ}C$ unless otherwise specified.

Output Over-Voltage Protection

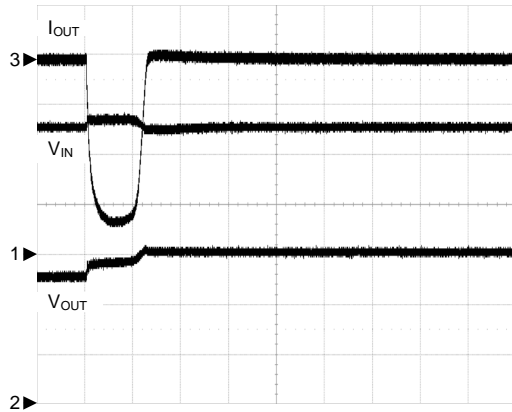

$C_{IN}=0.1\mu F$, $C_{OUT}=0.1\mu F$, $V_{OUT}=\text{open} \rightarrow 6V$, $R_{IN}=5\Omega$
 CH1: V_{IN} , 2V/Div, DC
 CH2: V_{OUT} , 2V/Div, DC
 CH3: I_{OUT} , 0.5A/Div, DC
 TIME: 20 μs /Div

Reverse Current Protection

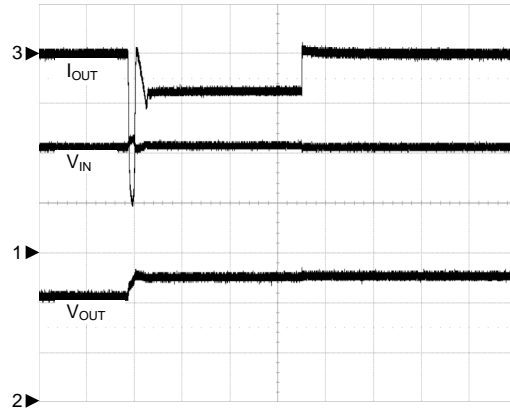

$C_{IN}=0.1\mu F$, $C_{OUT}=0.1\mu F$, $R_{IN}=5\Omega$
 $V_{IN}=4.2V$, $V_{OUT}=\text{open} \rightarrow 5V$
 CH1: V_{IN} , 2V/Div, DC
 CH2: V_{OUT} , 2V/Div, DC
 CH3: I_{OUT} , 0.5A/Div, DC
 TIME: 0.2ms/Div

Enable Response

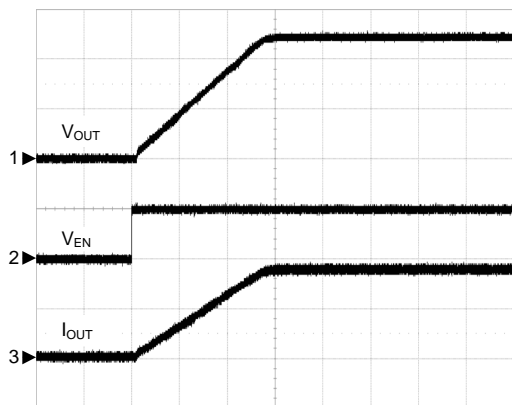

$C_{IN}=0.1\mu F$, $C_{OUT}=0.1\mu F$, $R_{OUT}=5\Omega$
 CH1: V_{OUT} , 2V/Div, DC
 CH2: V_{EN} , 5V/Div, DC
 CH3: I_{OUT} , 500mA/Div, DC
 TIME: 1ms/Div

Shutdown Response

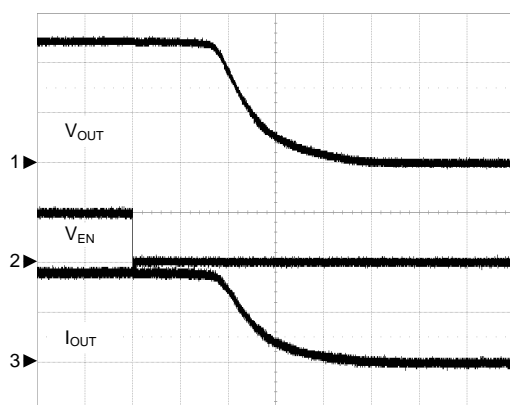

$C_{IN}=0.1\mu F$, $C_{OUT}=0.1\mu F$, $R_{OUT}=5\Omega$
 CH1: V_{OUT} , 2V/Div, DC
 CH2: V_{EN} , 5V/Div, DC
 CH3: I_{OUT} , 500mA/Div, DC
 TIME: 2 μs /Div

Pin Description

PIN		NAME	FUNCTION
NO.			
SOT-23-3	SOT-23-5		
1	1	GND	Ground.
2	3	VOUT	Output Voltage Pin. The output voltage follows the input voltage. When EN is low or V_{IN} is UVLO, the output voltage is discharged by an internal resistor.
3	4	VIN	Power Supply Input Connect this pin to external DC supply.
-	2	EN/ENB	Pulling the ENB above 2V or EN below 0.8V will disable the device, and pulling ENB pin below 0.8V or EN above 2V will enable the device. The EN and ENB pins cannot be left floating.
-	5	NC	Not Connected Internally.

Block Diagram

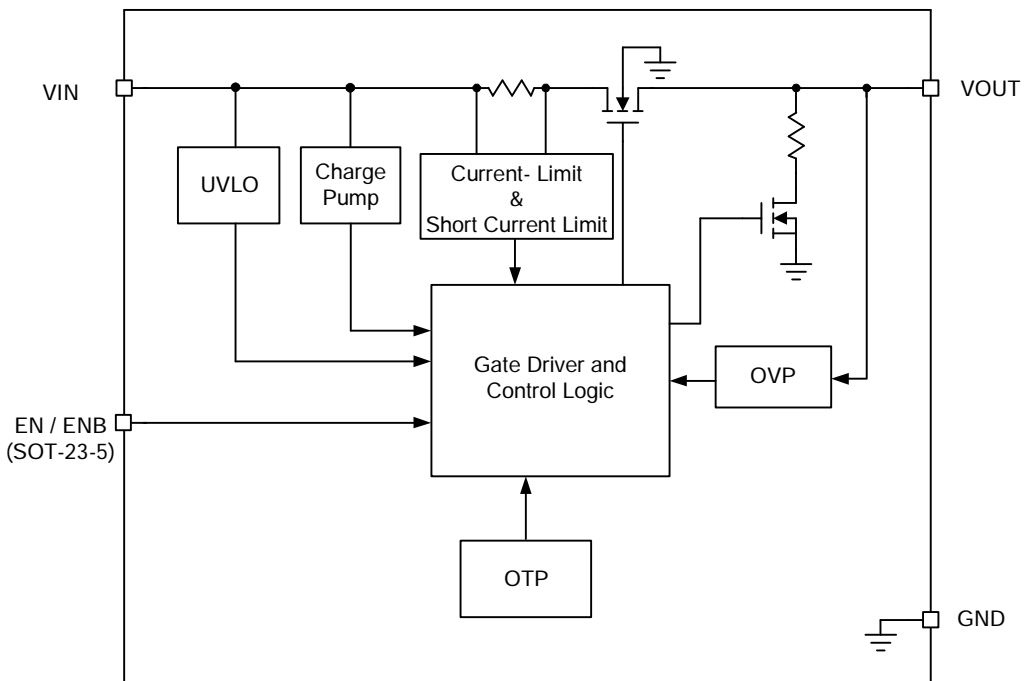

Typical Application Circuit

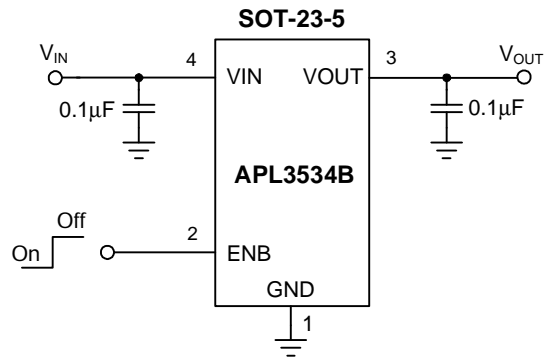
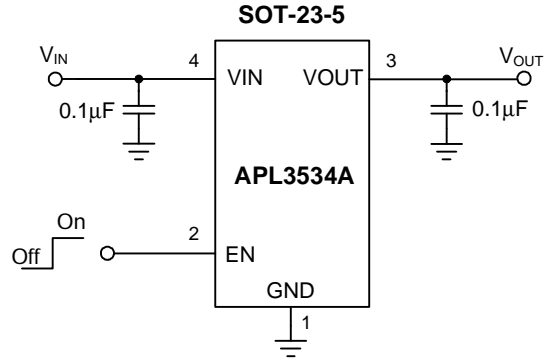
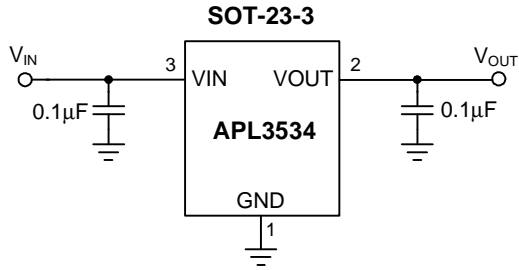

Function Description

VIN Under-voltage Lockout (UVLO)

The APL3534/A/B power switch has a built-in under-voltage lockout circuit to keep the output shut off until internal circuitry is operating properly. The UVLO circuit has hysteresis and a de-glitch feature so that it will typically ignore undershoot transients on the input. When input voltage exceeds the UVLO threshold, the output voltage starts a soft-start to reduce the inrush current.

Power Switch

The power switch is an N-channel MOSFET with a low $R_{DS(ON)}$. The internal power MOSFET does not have the body diode. When IC is in UVLO state, the MOSFET prevents a current flowing from the VOUT back to VIN and VIN to VOUT.

Current-Limit Protection

The APL3534/A/B power switch provides the current-limit protection function. During current-limit, the devices limit output current at current-limit threshold. For reliable operation, the device should not be operated in current-limit for extended period time.

Short-Circuit Protection

When the output voltage drops below 1.2V, which is caused by the over load or short-circuit, the devices limit the output current down to a safe level. The short-circuit current-limit is used to reduce the power dissipation during short-circuit condition. If the junction temperature is over the thermal shutdown temperature the device will enter the thermal shutdown. This Function is disabled during soft-start interval.

Soft-Start

The APLA3534/A/B has a built-in output soft-start control to limit the current surge during start-up. The soft-start interval is 2.5ms.

Output Over-Voltage Protection

The output over-voltage protection is implemented by 2 either sensing mechanisms. One is by sensing when V_{OUT} voltage is above V_{OVP} threshold, the internal power MOSFET is turned off. The other is by sensing when reverse current, flowing from VOUT to VIN, surpasses I_{RV} . When the reverse current reaches the reverse current Blocking threshold, the device limits the reverse current at I_{RV} threshold level. When the reverse current fault exists for more than 0.7ms, the internal power MOSFET is turned off. The internal power MOSFET is allowed to turn-on once the output voltage goes below $V_{IN}-1.2V$.

Output Discharge

When the input voltage is under VIN UVLO Threshold or $V_{EN}=Low$ or $V_{ENB}=High$, the output discharge device is turned on to discharge the output voltage.

Enable/Disable (SOT-23-5)

Pulling the ENB above 2V or EN below 0.8V will disable the device, and pulling ENB pin below 0.8V or EN above 2V will enable the device.

When the IC is disabled the supply current is reduced to less than 1 μ A. The enable input is compatible with both TTL and CMOS logic levels. The EN/ENB pins cannot be left floating.

Over-temperature Protection

When the junction temperature exceeds 140 $^{\circ}$ C, the internal thermal sense circuit turns off the power FET and allows the device to cool down. When the device's junction temperature cools by 20 $^{\circ}$ C, the internal thermal sense circuit will enable the device, resulting in a pulsed output during continuous thermal protection. Thermal protection is designed to protect the IC in the event of over-temperature conditions. For normal operation, the junction temperature cannot exceed $T_J=+125^{\circ}$ C.

Application Information

Input Capacitor

A 1µF or higher ceramic bypass capacitor from VIN to GND, located near the APL3534/A/B, is strongly recommended to suppress the ringing during short circuit fault event. When the load current trips the SCP threshold in an over load condition such as a short circuit, hot plug-in or heavy load transient the IC immediately turns off the internal power switch that will cause VIN ringing due to the inductance between power source and VIN. Without the bypass capacitor, the output short may cause sufficient ringing on the input to damage internal control circuitry. Input capacitor is especially important to prevent V_{IN} from ringing too high in some applications where the inductance between power source to VIN is large (ex, an extra bead is added between power source line to VIN for EMI reduction), additional input capacitance may be needed on the input to reduce voltage overshoot from exceeding the absolute maximum voltage of the device during over load conditions.

Thermal Consideration

The APL3534 maximum power dissipation depends on the differences of the thermal resistance and temperature between junction and ambient air. The power dissipation P_D across the device is:

$$P_D = (T_J - T_A) / \theta_{JA}$$

where $(T_J - T_A)$ is the temperature difference between the junction and ambient air. θ_{JA} is the thermal resistance between junction and ambient air. Assuming the $T_A = 25^\circ\text{C}$ and maximum $T_J = 140^\circ\text{C}$ (typical thermal limit threshold), the maximum power dissipation is calculated as:

$$P_{D(MAX)} = (140 - 25) / 260 = 0.44(\text{W})$$

For normal operation, do not exceed the maximum operating junction temperature of $T_J = 125^\circ\text{C}$. The calculated power dissipation should be less than:

$$P_D = (125 - 25) / 260 = 0.38(\text{W}) \text{ ----- } T_A = 25^\circ\text{C}$$

$$P_D = (125 - 85) / 260 = 0.15(\text{W}) \text{ ----- } T_A = 85^\circ\text{C}$$

The power dissipation depends on operating ambient temperature for fixed $T_J = 125^\circ\text{C}$ and thermal resistance θ_{JA} . For APL3534 packages, the Figure 1 of derating curves allows the designer to see the effect of rising ambient temperature on the maximum power allowed.

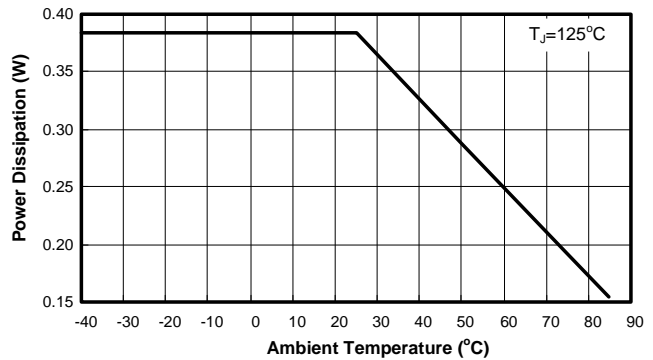

Figure 1. Derating Curves for APL3534 Package

Layout Consideration

The PCB layout should be carefully performed to maximize thermal dissipation and to minimize voltage drop, droop and EMI. The following guidelines must be considered:

1. Please place the input capacitors near the VIN pin as close as possible.
2. Output decoupling capacitors for load must be placed near the load as close as possible for decoupling high-frequency ripples.

3. Locate APL3534/A/B and output capacitors near the load to reduce parasitic resistance and inductance for excellent load transient performance.
4. The negative pins of the input and output capacitors and the GND pin must be connected to the ground plane of the load.
5. Keep V_{IN} and V_{OUT} traces as wide and short as possible.

Application Information

Recommended Minimum Footprint

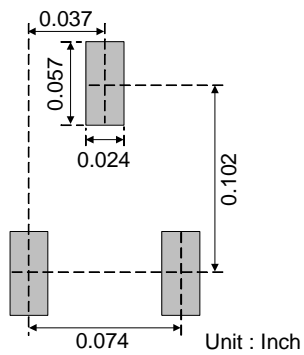

SOT-23-3

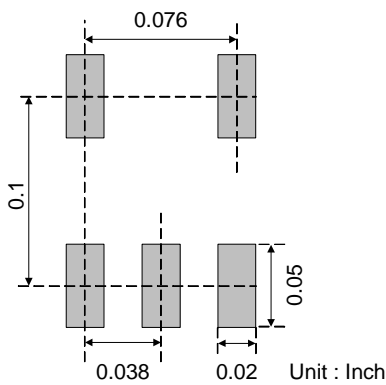

SOT-23-5

Package Information

SOT-23-3

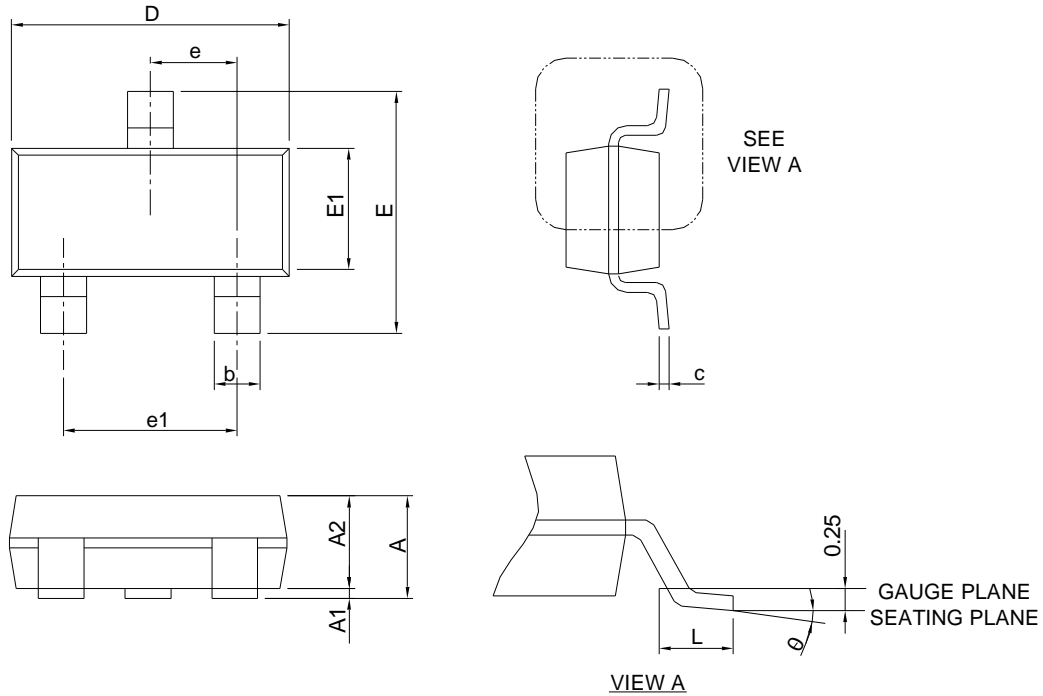

SYMBOL	SOT-23-3			
	MILLIMETERS		INCHES	
	MIN.	MAX.	MIN.	MAX.
A		1.45		0.057
A1	0.00	0.15	0.000	0.006
A2	0.90	1.30	0.035	0.051
b	0.30	0.50	0.012	0.020
c	0.08	0.22	0.003	0.009
D	2.70	3.10	0.106	0.122
E	2.60	3.00	0.102	0.118
E1	1.40	1.80	0.055	0.071
e	0.95 BSC		0.037 BSC	
e1	1.90 BSC		0.075 BSC	
L	0.30	0.60	0.012	0.024
θ	0°	8°	0°	8°

Note : Dimension D and E1 do not include mold flash, protrusions or gate burrs. Mold flash, protrusion or gate burrs shall not exceed 10 mil per side.

Package Information

SOT-23-5

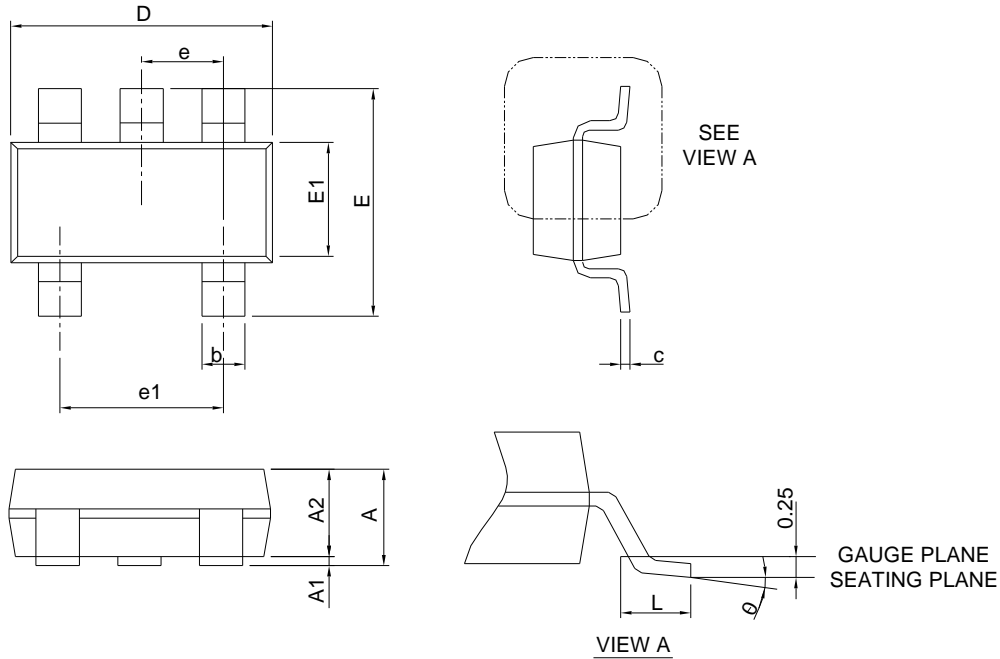

SYMBOL	SOT-23-5			
	MILLIMETERS		INCHES	
	MIN.	MAX.	MIN.	MAX.
A		1.45		0.057
A1	0.00	0.15	0.000	0.006
A2	0.90	1.30	0.035	0.051
b	0.30	0.50	0.012	0.020
c	0.08	0.22	0.003	0.009
D	2.70	3.10	0.106	0.122
E	2.60	3.00	0.102	0.118
E1	1.40	1.80	0.055	0.071
e	0.95 BSC		0.037 BSC	
e1	1.90 BSC		0.075 BSC	
L	0.30	0.60	0.012	0.024
θ	0°	8°	0°	8°

Note : 1. Follow JEDEC TO-178 AA.
 2. Dimension D and E1 do not include mold flash, protrusions or gate burrs. Mold flash, protrusion or gate burrs shall not exceed 10 mil per side.

Carrier Tape & Reel Dimensions

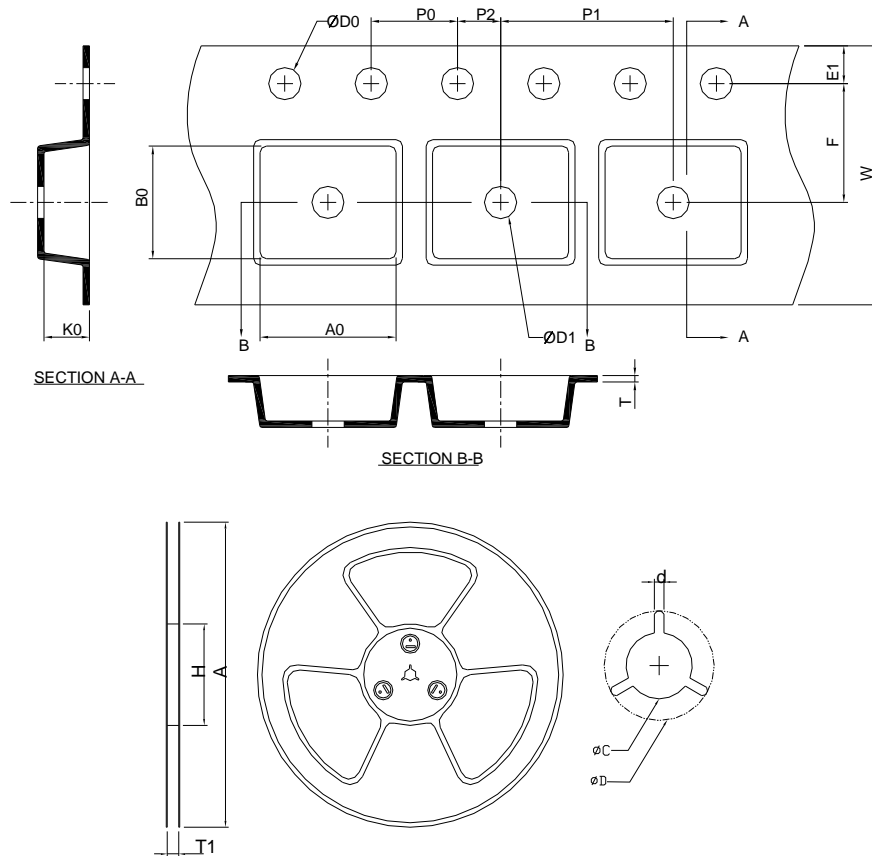

Application	A	H	T1	C	d	D	W	E1	F
SOT-23-3	178.0±2.00	50 MIN.	8.4+2.00 -0.00	13.0+0.50 -0.20	1.5 MIN.	20.2 MIN.	8.0±0.30	1.75±0.10	3.5±0.05
	P0	P1	P2	D0	D1	T	A0	B0	K0
	4.0±0.10	4.0±0.10	2.0±0.05	1.5+0.10 -0.00	1.0 MIN.	0.6+0.00 -0.40	3.20±0.20	3.10±0.20	1.50±0.20
Application	A	H	T1	C	d	D	W	E1	F
SOT-23-5	178.0±2.00	50 MIN.	8.4+2.00 -0.00	13.0+0.50 -0.20	1.5 MIN.	20.2 MIN.	8.0±0.30	1.75±0.10	3.5±0.05
	P0	P1	P2	D0	D1	T	A0	B0	K0
	4.0±0.10	4.0±0.10	2.0±0.05	1.5+0.10 -0.00	1.0 MIN.	0.6+0.00 -0.40	3.20±0.20	3.10±0.20	1.50±0.20

(mm)

Devices Per Unit

Package Type	Unit	Quantity
SOT-23-3	Tape & Reel	3000
SOT-23-5	Tape & Reel	3000

Taping Direction Information

SOT-23-3

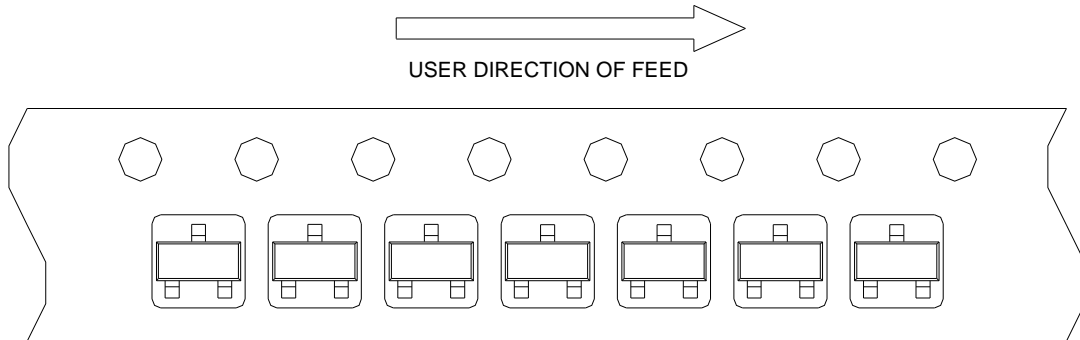

SOT-23-5

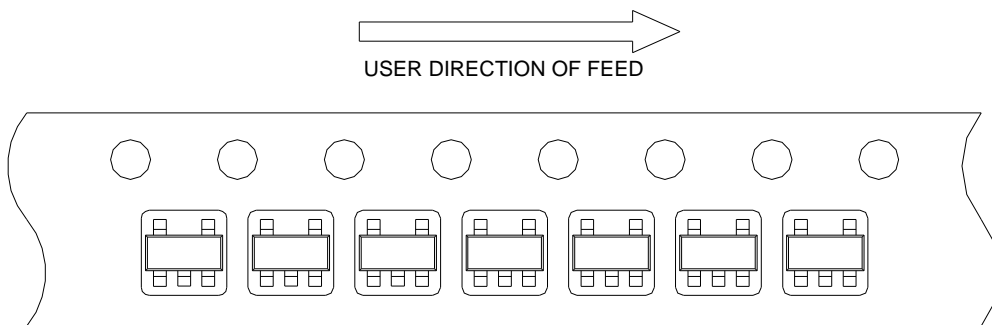

Classification Profile

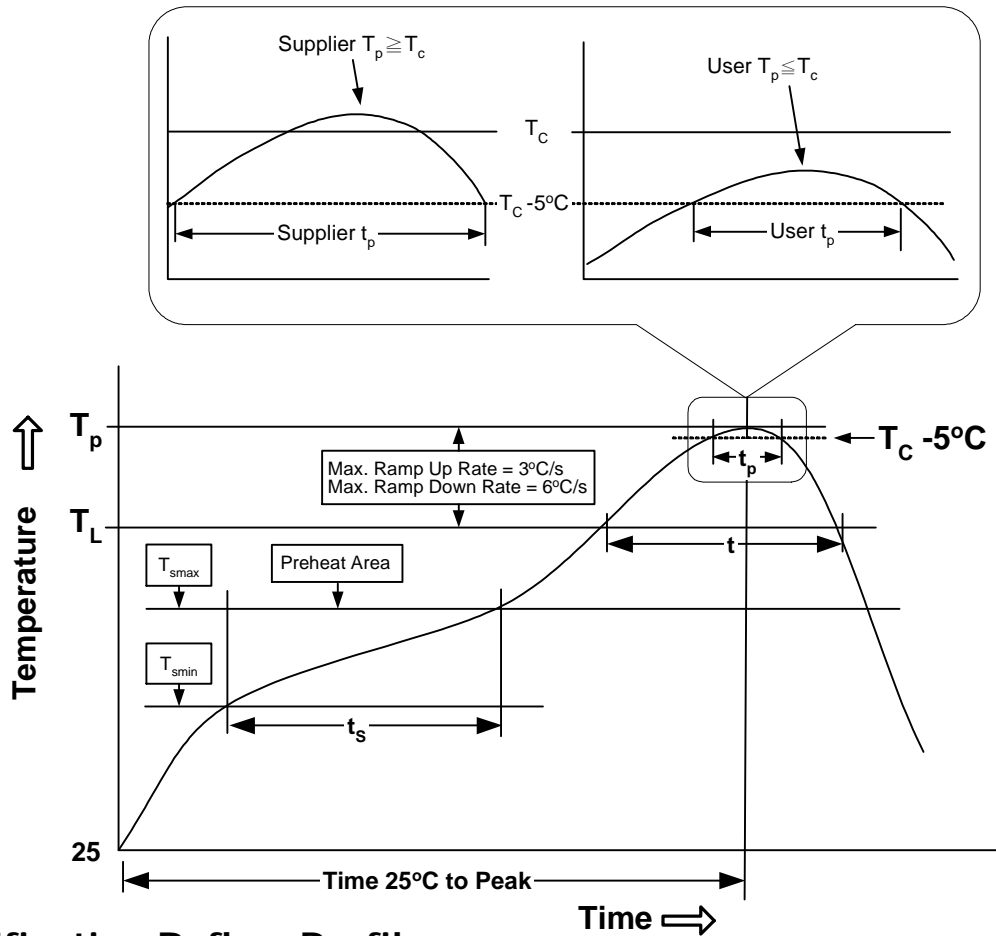

Classification Reflow Profiles

Profile Feature	Sn-Pb Eutectic Assembly	Pb-Free Assembly
Preheat & Soak		
Temperature min (T_{smin})	100 °C	150 °C
Temperature max (T_{smax})	150 °C	200 °C
Time (T_{smin} to T_{smax}) (t_s)	60-120 seconds	60-120 seconds
Average ramp-up rate (T_{smax} to T_p)	3 °C/second max.	3 °C/second max.
Liquidous temperature (T_L)	183 °C	217 °C
Time at liquidous (t_L)	60-150 seconds	60-150 seconds
Peak package body Temperature (T_p)*	See Classification Temp in table 1	See Classification Temp in table 2
Time (t_p)** within 5°C of the specified classification temperature (T_c)	20** seconds	30** seconds
Average ramp-down rate (T_p to T_{smax})	6 °C/second max.	6 °C/second max.
Time 25°C to peak temperature	6 minutes max.	8 minutes max.
* Tolerance for peak profile Temperature (T_p) is defined as a supplier minimum and a user maximum.		
** Tolerance for time at peak profile temperature (t_p) is defined as a supplier minimum and a user maximum.		

Classification Reflow Profiles (Cont.)

Table 1. SnPb Eutectic Process – Classification Temperatures (Tc)

Package Thickness	Volume mm ³ <350	Volume mm ³ ≥350
<2.5 mm	235 °C	220 °C
≥2.5 mm	220 °C	220 °C

Table 2. Pb-free Process – Classification Temperatures (Tc)

Package Thickness	Volume mm ³ <350	Volume mm ³ 350-2000	Volume mm ³ >2000
<1.6 mm	260 °C	260 °C	260 °C
1.6 mm – 2.5 mm	260 °C	250 °C	245 °C
≥2.5 mm	250 °C	245 °C	245 °C

Reliability Test Program

Test item	Method	Description
SOLDERABILITY	JESD-22, B102	5 Sec, 245°C
HOLT	JESD-22, A108	1000 Hrs, Bias @ T _j =125°C
PCT	JESD-22, A102	168 Hrs, 100%RH, 2atm, 121°C
TCT	JESD-22, A104	500 Cycles, -65°C~150°C
HBM	MIL-STD-883-3015.7	VHBM ≥ 2KV
MM	JESD-22, A115	VMM ≥ 200V
Latch-Up	JESD 78	10ms, I _{tr} ≥ 100mA

Customer Service

Anpec Electronics Corp.

Head Office :

No.6, Dusing 1st Road, SBIP,
Hsin-Chu, Taiwan, R.O.C.
Tel : 886-3-5642000
Fax : 886-3-5642050

Taipei Branch :

2F, No. 11, Lane 218, Sec 2 Jhongsing Rd.,
Sindian City, Taipei County 23146, Taiwan
Tel : 886-2-2910-3838
Fax : 886-2-2917-3838