

# SN54F518, SN54F519, SN74F518, SN74F519 8-BIT IDENTITY COMPARATORS WITH OPEN-COLLECTOR OUTPUTS

D2932, MARCH 1987—REVISED JANUARY 1989

- Compares Two 8-Bit Words
- 'F518 Has 20-k $\Omega$  Pull-up Resistors on Q Inputs
- Package Options Include Plastic "Small Outline" Packages, Ceramic Chip Carriers, and Standard Plastic and Ceramic 300-mil DIPs
- Dependable Texas Instruments Quality and Reliability

## description

These identity comparators perform comparisons on two eight-bit binary or BCD words. The 'F518 and F519 provide P = Q open-collector outputs. The 'F518 devices feature 20-k $\Omega$  pull-up termination resistors on the Q inputs for analog or switch data.

The SN54F518 and SN54F519 are characterized for operation over the full military temperature range of -55°C to 125°C. The SN74F518 and SN74F519 are characterized for operation from 0°C to 70°C.

## logic symbol†

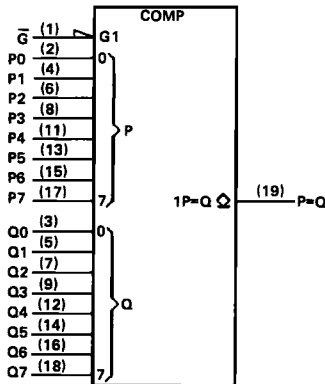

† This symbol is in accordance with ANSI/IEEE Std 91-1984 and IEC Publication 617-12.

SN54F518, SN54F519 . . . J PACKAGE  
SN74F518, SN74F519 . . . DW OR N PACKAGE

(TOP VIEW)

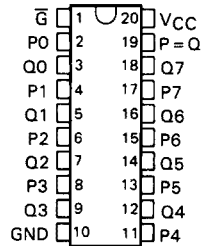

SN54F518, SN54F519 . . . FK PACKAGE

(TOP VIEW)

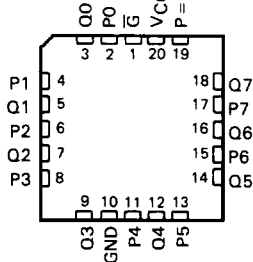

FUNCTION TABLE

INPUTS		OUTPUT P = Q
DATA P, Q	ENABLE G-bar	
P = Q	L	H
P $\neq$ Q	X	L
X	H	L

**SN54F518, SN54F519, SN74F518, SN74F519**  
**8-BIT IDENTITY COMPARATORS WITH OPEN-COLLECTOR OUTPUTS**

logic diagram (positive logic)

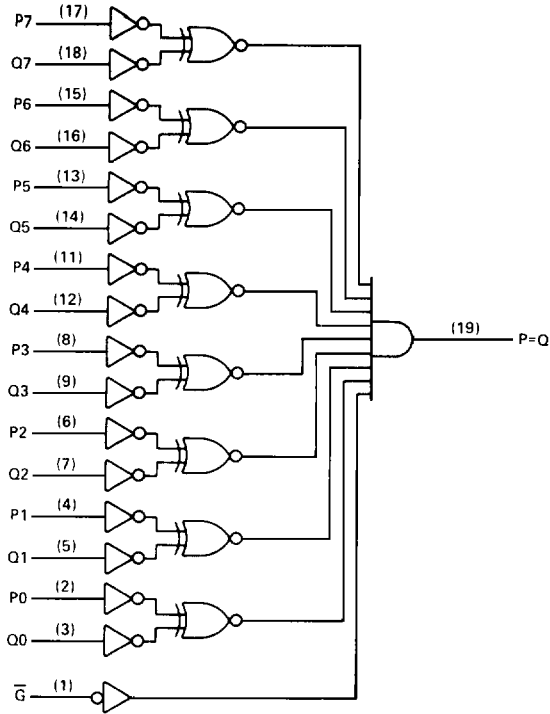

2

Data Sheets

**absolute maximum ratings over operating free-air temperature range (unless otherwise noted)**

Supply voltage, $V_{CC}$ .....	-0.5 V to 7 V
Input voltage <sup>†</sup> .....	-1.2 V to 7 V
Input current .....	-30 mA to 5 mA
Voltage applied to any output in the high state .....	-0.5 V to 5.5 V
Current into any output in the low state .....	40 mA
Operating free-air temperature range: SN54F518, SN54F519 .....	-55°C to 125°C
SN74F518, SN74F519 .....	0°C to 70°C
Storage temperature range .....	-65°C to 150°C

<sup>†</sup>The input voltage ratings may be exceeded provided the input current ratings are observed.

# SN54F518, SN74F518

## 8-BIT IDENTITY COMPARATORS WITH OPEN-COLLECTOR OUTPUTS

### recommended operating conditions

	SN54F518			SN74F518			UNIT
	MIN	NOM	MAX	MIN	NOM	MAX	
V <sub>CC</sub> Supply voltage	4.5	5	5.5	4.75	5	5.5	V
V <sub>IH</sub> High-level input voltage	2			2			V
V <sub>IL</sub> Low-level input voltage			0.8			0.8	V
V <sub>OH</sub> High-level output voltage			5.5			5.5	V
I <sub>OL</sub> Low-level output current			20			20	mA
T <sub>A</sub> Operating free-air temperature	-55		125	0		70	°C

### electrical characteristics over recommended operating free-air temperature range (unless otherwise noted)

PARAMETER	TEST CONDITIONS	SN54F518			SN74F518			UNIT
		MIN	TYP <sup>†</sup>	MAX	MIN	TYP <sup>†</sup>	MAX	
V <sub>IK</sub>	V <sub>CC</sub> = 4.5 V, I <sub>I</sub> = -18 mA			-1.2			-1.2	V
I <sub>OH</sub>	V <sub>CC</sub> = 4.5 V, V <sub>OH</sub> = 5.5 V			0.1			0.1	mA
V <sub>OL</sub>	V <sub>CC</sub> = 4.5 V, I <sub>OL</sub> = 20 mA		0.30	0.5		0.30	0.5	V
I <sub>I</sub>	$\bar{Q}$ and P inputs			0.1			0.1	mA
	Q inputs	V <sub>CC</sub> = 5.5 V, V <sub>I</sub> = 7 V						
I <sub>IH</sub>	$\bar{Q}$ and P inputs			20			20	μA
	Q inputs	V <sub>CC</sub> = 5.5 V, V <sub>I</sub> = 2.7 V						
I <sub>IL</sub>	$\bar{Q}$ and P inputs			-0.3			-0.3	mA
	Q inputs	V <sub>CC</sub> = 5.5 V, V <sub>I</sub> = 0.5 V						
I <sub>CC</sub>	V <sub>CC</sub> = 5.5 V, See Note 1		24	39		24	39	mA

### switching characteristics (see Note 2)

PARAMETER	FROM (INPUT)	TO (OUTPUT)	V <sub>CC</sub> = 5 V, C <sub>L</sub> = 50 pF, R <sub>L</sub> = 500 Ω, T <sub>A</sub> = 25°C			V <sub>CC</sub> = 4.5 V to 5.5 V, C <sub>L</sub> = 50 pF, R <sub>L</sub> = 500 Ω, T <sub>A</sub> = MIN to MAX <sup>‡</sup>				UNIT
			'F518			SN54F518		SN74F518		
			MIN	TYP	MAX	MIN	MAX	MIN	MAX	
t <sub>PLH</sub>	P or Q	P = Q	4	11.5	14.5	4	15.5	4	10	ns
t <sub>PHL</sub>			2	6.2	9	2	11.5	2	10	
t <sub>PLH</sub>	$\bar{Q}$	P = Q	4.5	11.5	14	4.5	15.5	4.5	14.5	ns
t <sub>PHL</sub>			2	5.1	6.5	2	9.5	2	7.5	

<sup>†</sup>All typical values are at V<sub>CC</sub> = 5 V, T<sub>A</sub> = 25°C

<sup>‡</sup>For conditions shown as MIN or MAX, use the appropriate value specified under Recommended Operating Conditions.

NOTES: 1. I<sub>CC</sub> is measured with all inputs at 4.5 V.

2. Load circuits and waveforms are shown in Section 1.

2  
Data Sheets

# SN54F519, SN74F519

## 8-BIT IDENTITY COMPARATORS WITH OPEN-COLLECTOR OUTPUTS

### recommended operating conditions

	SN54F519			SN74F519			UNIT
	MIN	NOM	MAX	MIN	NOM	MAX	
V <sub>CC</sub> Supply voltage	4.5	5	5.5	4.75	5	5.5	V
V <sub>IH</sub> High-level input voltage	2			2			V
V <sub>IL</sub> Low-level input voltage			0.8			0.8	V
V <sub>OH</sub> High-level output voltage			5.5			5.5	V
I <sub>OL</sub> Low-level output current			20			20	mA
T <sub>A</sub> Operating free-air temperature	-55		125	0		70	°C

### electrical characteristics over recommended operating free-air temperature range (unless otherwise noted)

PARAMETER	TEST CONDITIONS	SN54F519		SN74F519		UNIT	
		MIN	TYP†	MAX	MIN		TYP†
V <sub>IK</sub>	V <sub>CC</sub> = 4.5 V, I <sub>I</sub> = -18 mA			-1.2		-1.2	V
I <sub>OH</sub>	V <sub>CC</sub> = 4.5 V, V <sub>OH</sub> = 5.5 V			0.1		0.1	mA
V <sub>OL</sub>	V <sub>CC</sub> = 4.5 V, I <sub>OL</sub> = 20 mA	0.30	0.5	0.30	0.5		V
I <sub>I</sub>	V <sub>CC</sub> = 5.5 V, V <sub>I</sub> = 7 V		0.1			0.1	mA
I <sub>IH</sub>	V <sub>CC</sub> = 5.5 V, V <sub>I</sub> = 2.7 V		20			20	μA
I <sub>IL</sub>	V <sub>CC</sub> = 5.5 V, V <sub>I</sub> = 0.5 V		-0.6			-0.6	mA
I <sub>CC</sub>	V <sub>CC</sub> = 5.5 V, See Note 1	24	39	24	39		mA

### switching characteristics (see Note 2)

PARAMETER	FROM (INPUT)	TO (OUTPUT)	V <sub>CC</sub> = 5 V, C <sub>L</sub> = 50 pF, R <sub>L</sub> = 500 Ω, T <sub>A</sub> = 25°C			V <sub>CC</sub> = 4.5 V to 5.5 V C <sub>L</sub> = 50 pF, R <sub>L</sub> = 500 Ω, T <sub>A</sub> = MIN to MAX‡				UNIT
			'F519			SN54F519		SN74F519		
			MIN	TYP	MAX	MIN	MAX	MIN	MAX	
t <sub>PLH</sub>	P or Q	P = Q	4	11.5	14.5	4	15.5	4	15	ns
t <sub>PHL</sub>			2	6.2	9	2	11.5	2	10	
t <sub>PLH</sub>	Q	P = Q	4.5	11.5	14	4.5	15.5	4.5	14.5	ns
t <sub>PHL</sub>			2	5.1	6.5	2	9.5	2	7.5	

†All typical values are at V<sub>CC</sub> = 5 V, T<sub>A</sub> = 25°C.

‡For conditions shown as MIN or MAX, use the appropriate value specified under Recommended Operating Conditions.

NOTES: 1. I<sub>CC</sub> is measured with inputs at 4.5 V.

2. Load circuits and waveforms are shown in Section 1.