

This document is the property of Amphenol Corporation and is delivered on the express condition that it not be disclosed, reproduced or used, in whole or in part, for manufacture or sale by anyone other than Amphenol Corporation without its prior consent, and that no right is granted to disclose or to use any information in this document.

The marking on this product doesn't contain environmental hazardous materials per Material Specification SS-00259 for Sony GP compliant or per directive 2011/65/EU for RoHS compliant or per IEC 61249-2-21 for Halogen-Free compliant.

REVISIONS				
SYM	ECN No.	DESCRIPTION	DATE	BY
AX1		INITIAL REVISION	03/08/2018	Chenny Yeh
AX2		ADD P/S OPTION	04/11/2019	Chenny Yeh
AX3		MODIFIED KEY SHAPE	06/24/2018	Chenny Yeh
AX4		ADD SPECIAL KEY	08/19/2019	Chenny Yeh

FOR REFERENCE ONLY

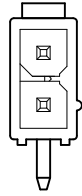

2*1

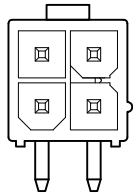

2*2

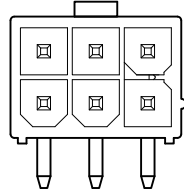

2*3

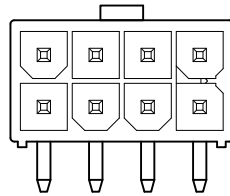

2*4

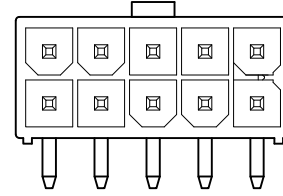

2*5

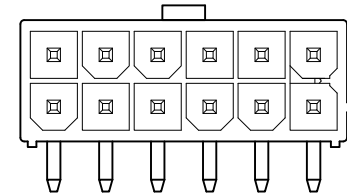

2*6

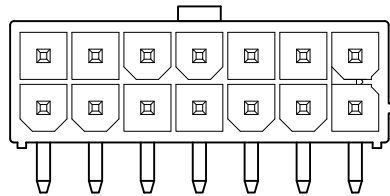

2*7

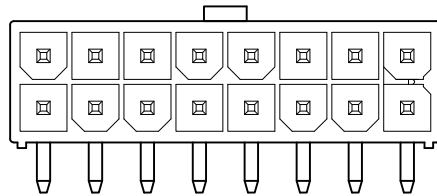

2*8

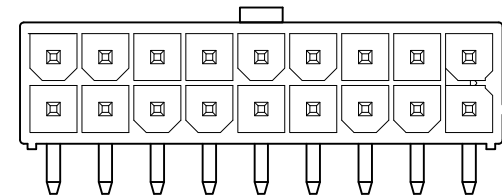

2*9

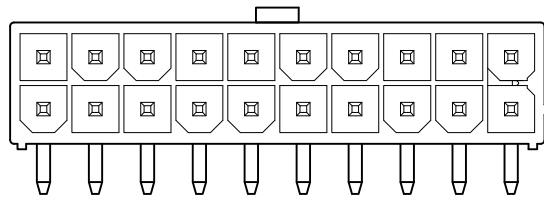

2*10

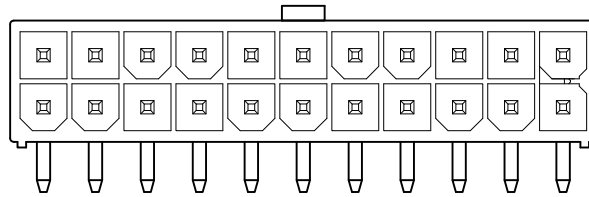

2*11

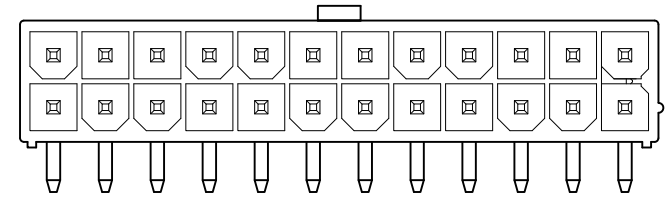

2*12

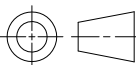
TOLERANCE	DRAWN	APPROVALS	DATE	TITLE	Amphenol [®] Amphenol Corporation Amphenol Taiwan Corporation							
X. X.X ±0.30 X.XX ±0.20 X.XXX ±0.10	DESIGNED	Chenny Yeh	08/19/2019	G87MPS SERIES MINI POWER SUPER CONN. 4.20 x5.5 PITCH, HEADER R/A, DIP TYPE								
ANGULAR ±2°	CHECKED	Sondra Sang	08/19/2019		UNIT	mm	SIZE	A3	PART No.	G87MPSXX2X0XCHR		
UNLESS OTHERWISE SPECIFIED	DWG TYPE	CUST DWG	PROJECT CODE		T652	SCALE	NA	SHEET	2 OF 3	DWG No.	G87MPSXX2X0XCHR	REV.

This document is the property of Amphenol Corporation and is delivered on the express condition that is not to be disclosed, reproduced or used, in whole or in part, for manufacture or sale by anyone other than Amphenol Corporation without its prior consent, and that no right is granted to disclose or to use any information in this document.

The marking on this product doesn't contain environmental hazardous materials per Material Specification SS-00259 for Sony GP compliant or per directive 2011/65/EU for RoHS compliant or per IEC 61249-2-21 for Halogen-Free compliant.

REVISIONS				
SYM	ECN No.	DESCRIPTION	DATE	BY
AX1		INITIAL REVISION	03/08/2018	Chenny Yeh
AX2		ADD P/S OPTION	04/11/2019	Chenny Yeh
AX3		MODIFIED KEY SHAPE	06/24/2018	Chenny Yeh
AX4		ADD SPECIAL KEY	08/19/2019	Chenny Yeh

FOR REFERENCE ONLY

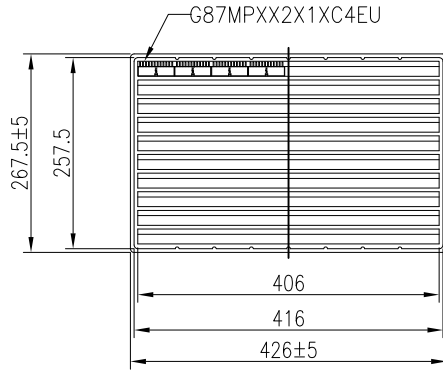

TRAY BOTTOM COVER

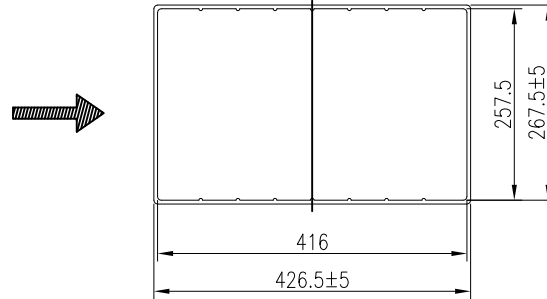

TRAY TOP COVER

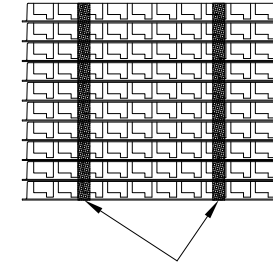

PE MEMBRANE

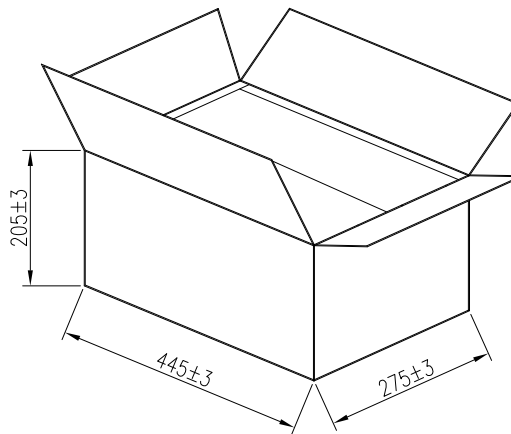

(10 INSIDE CARTON)

POS	PCS/TRAY	PCS/CARTON	N/W(kg)	G/W(kg)
02	260	2600	3.69	5.12
04	200	2000	4.32	5.75
06	160	1600	4.64	6.07
08	140	1400	5.11	6.54
10	120	1200	5.50	6.92
12	110	1100	5.85	7.28
14	90	900	5.45	6.88
16	90	900	6.38	7.81
18	80	800	6.65	8.07
20	70	700	6.34	7.76
22	70	700	6.85	8.28
24	60	600	6.26	7.69

TOLERANCE	DRAWN	APPROVALS	DATE	TITLE	Amphenol® Amphenol Corporation Amphenol Taiwan Corporation			
X. ±0.30	DESIGNED	Chenny Yeh	08/19/2019	G87MPS SERIES MINI POWER SUPER CONN. 4.20 x5.5 PITCH, HEADER R/A, DIP TYPE	 UNIT mm SIZE A3 SCALE NA SHEET 3 OF 3	PART No. G87MPSXX2X0XCHR		
X.X ±0.20	CHECKED	Sondra Sang	08/19/2019			DWG No. G87MPSXX2X0XCHR		
X.XXX ±0.10	APPROVED	Hank Hsu	08/19/2019			REV. AX4		
ANGULAR ±2°	DWG TYPE	CUST DWG				PROJECT CODE T652		
UNLESS OTHERWISE SPECIFIED								