

FEATURES

- **LOW COST**
- **LOW NOISE FIGURE**
0.8 dB at 4 GHz
1.7 dB at 8 GHz
- **HIGH ASSOCIATED GAIN**
12.0 dB at 4 GHz
9.0 dB at 8 GHz
- **HIGH MAXIMUM AVAILABLE GAIN**
16.0 dB at 4 GHz
12.0 dB at 8 GHz

DESCRIPTION

The NE720 is NEC's low cost 1.0 μm recessed gate GaAs FET, offering a low noise figure and high gain through 8 GHz. It is designed for consumer applications.

The device is available as a chip (NE72000) and in a hermetically sealed stripline package (NE72089A). The chip's gate and channel are glassivated with a thin layer of SiO₂ for mechanical protection. All bonding pads use a Ti-Pt-Au metallization system.

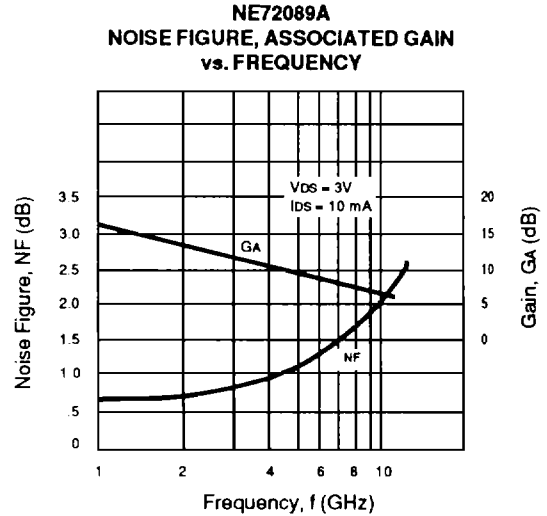

ELECTRICAL CHARACTERISTICS (TA = 25°C)

PART NUMBER EIAJ ¹ REGISTERED NUMBER PACKAGE OUTLINE			NE72000 ³ CHIP			NE72089A ⁴ 2SK354A 89A		
SYMBOLS	PARAMETERS AND CONDITIONS	UNITS	MIN	TYP	MAX	MIN	TYP	MAX
f _{MAX}	Maximum Frequency of Oscillation at V _{DS} = 3 V, I _{DS} = 30 mA	GHz		60			60	
MAG	Maximum Available Gain ² at V _{DS} = 3 V, I _{DS} = 30 mA (Typ. I _{DS} = 50% I _{DSS}) f = 4 GHz f = 8 GHz	dB dB		16.5 11.5			16.0 11.0	
NF _{OPT}	Optimum Noise Figure at V _{DS} = 3 V, I _{DS} = 10 mA (Typ. I _{DS} = 15% I _{DSS}) f = 4 GHz f = 8 GHz	dB dB		1.0 1.7	1.4		1.0 1.7	1.4
GA	Associated Gain at V _{DS} = 3 V, I _{DS} = 10 mA (Typ. I _{DS} = 15% I _{DSS}) f = 4 GHz f = 8 GHz	dB dB		11.0 9.0			11.0 8.5	
P _{1dB}	Output Power at 1 dB Compression Point at V _{DS} = 4 V, I _{DS} = 30 mA (Typ. I _{DS} = 50% I _{DSS}) f = 4 GHz	dBm		15.0			15.0	

Notes:

1. Electronic Industrial Association of Japan.
2. Gain Calculations:

$$MAG = \frac{|S_{21}|}{|S_{12}|} (K \pm \sqrt{K^2 - 1})$$

When $K \leq 1$, MAG is undefined and MSG values are used. $MSG = \frac{|S_{21}|}{|S_{12}|}$, $K = \frac{1 + |\Delta|^2 - |S_{11}|^2 - |S_{22}|^2}{2 |S_{12} S_{21}|}$, $\Delta = S_{11} S_{22} - S_{21} S_{12}$

MAG = Maximum Available Gain

MSG = Maximum Stable Gain

3. RF performance is determined by packaging and testing 10 samples per wafer; wafer rejection criteria for standard devices is 2 rejects for 10 samples.
4. NE72089A is not recommended for new designs.

NE720 SERIES

ABSOLUTE MAXIMUM RATINGS¹ (T_A = 25°C)

SYMBOLS	PARAMETERS	UNITS	RATINGS
V _{DS}	Drain to Source Voltage	V	5.0
V _{GD0}	Gate to Drain Voltage	V	-6.0
V _{GS0}	Gate to Source Voltage	V	-6.0
I _{GF}	Gate Current	mA	4.0
I _{DS}	Drain Current	mA	I _{DSS}
T _{CH}	Channel Temperature	°C	175
T _{STG}	Storage Temperature NE72089A	°C	-65 to +175
P _T	Total Power Dissipation NE72089A NE72000	mW mW	300 500

Note:

1. Operation in excess of any one of these parameters may result in permanent damage.

TYPICAL PERFORMANCE CURVES

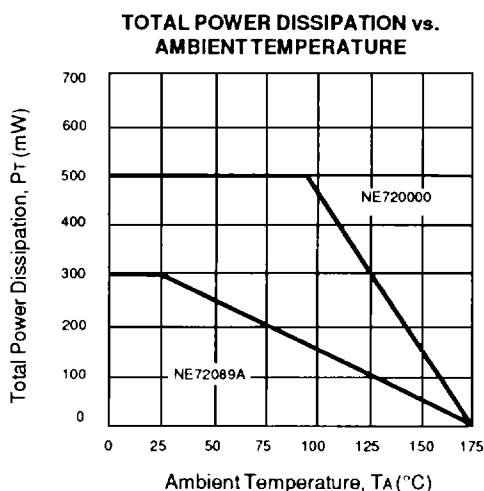

NE72000 EQUIVALENT CIRCUIT

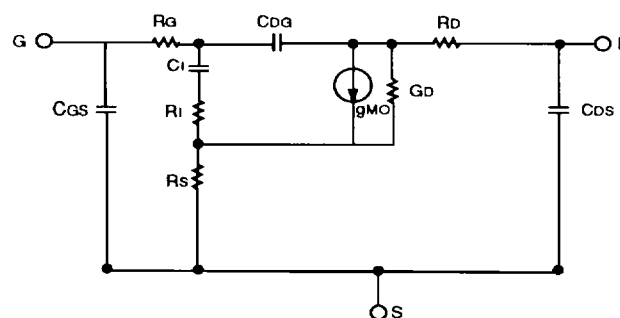

Components	Value
R _G	0.57Ω
C _I	0.15pF
R _I	2.00Ω
R _S	2.00Ω
C _{DG}	0.03 pF
R _D	2.00Ω
C _{DS}	0.015 pF
g _{mO}	40.0 mS
G _D	2.0 mS
C _{GS}	0.55 pF

NE72089A TYPICAL NOISE PARAMETERS

(V_{DS} = 3 V, I_{DS} = 10 mA)

FREQ. (GHz)	NF _{OPT} (dB)	G _A (dB)	Γ _{OPT}		R _{n/50}
			MAG	ANG	
1.0	0.60	17.5	0.76	13	0.68
2.0	0.75	14.5	0.73	36	0.58
4.0	1.00	11.5	0.65	68	0.42
6.0	1.30	9.0	0.53	100	0.28
8.0	1.70	8.5	0.42	138	0.19
10.0	2.05	7.0	0.31	175	0.15
12.0	2.50	6.5	0.25	-117	0.25

ELECTRICAL CHARACTERISTICS (T_A = 25°C)

PART NUMBER EIAJ ¹ REGISTERED NUMBER PACKAGE OUTLINE			NE72000 CHIP			NE72089A 2SK354A 89A		
SYMBOLS	PARAMETERS AND CONDITIONS	UNITS	MIN	TYP	MAX	MIN	TYP	MAX
I _{DSS}	Saturated Drain Current at V _{DS} = 3 V, V _{GS} = 0	mA	30	60	150	30	60	150
V _P	Pinch-off Voltage at V _{DS} = 3 V, I _{DS} = 0.1 mA	V	-0.8	-2.0	-4.0	-0.8	-2.0	-4.0
g _m	Transconductance at V _{DS} = 3 V, I _{DS} = 10 mA	mS	20	40	60	20	40	60
I _{GS}	Gate to Source Leakage Current at V _{GS} = -5 V	μA		1.0	10		1.0	10
R _{TH(CH-A)}	Thermal Resistance (Channel-to-Ambient)	°C/W			170 ²			400

Notes:

1. Electronic Industrial Association of Japan.
2. R_{TH}(Channel-to-Case) for chips mounted on an infinite heat sink.

TYPICAL PERFORMANCE CURVES (TA = 25°C)

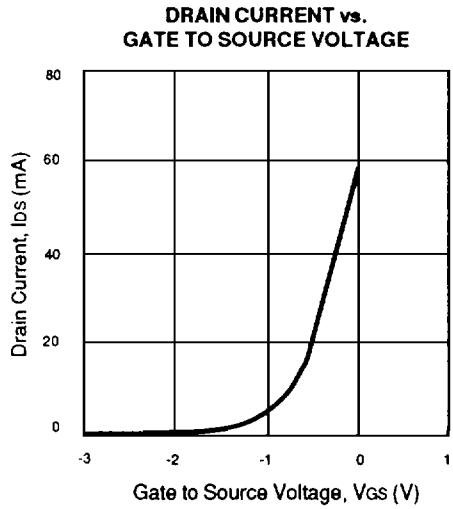
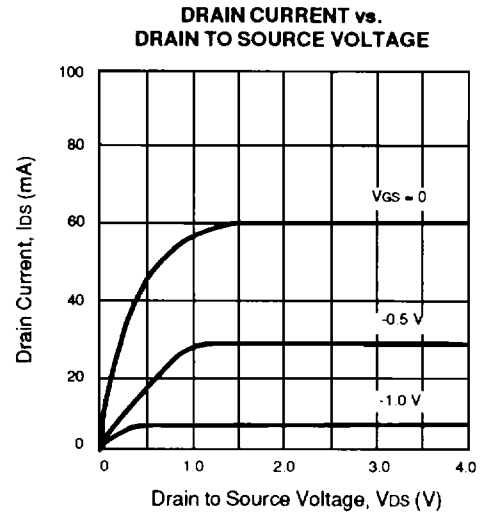
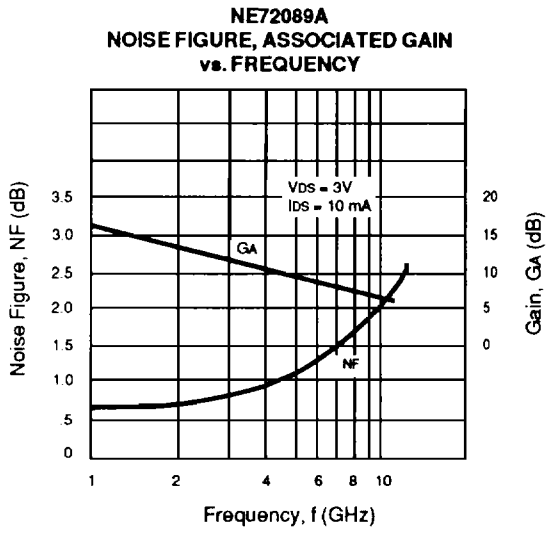

1

NE720 SERIES

TYPICAL COMMON SOURCE SCATTERING PARAMETERS ($T_A = 25^\circ\text{C}$)

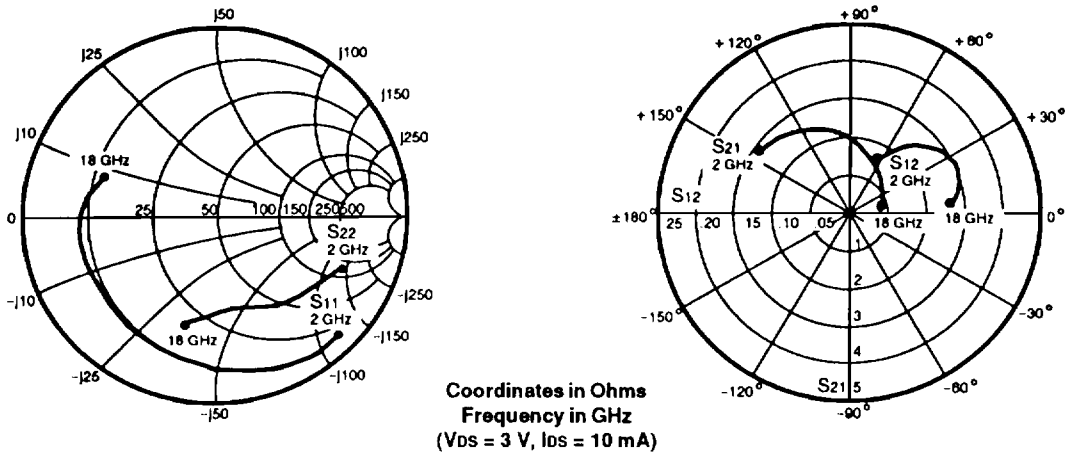

NE72000
 $V_{ds} = 3\text{ V}$, $I_{ds} = 10\text{ mA}$

FREQUENCY (GHz)	S ₁₁		S ₂₁		S ₁₂		S ₂₂	
	MAG	ANG	MAG	ANG	MAG	ANG	MAG	ANG
2.0	.91	-44	2.95	144	.08	64	.71	-22
3.0	.90	-63	2.81	132	.11	53	.68	-27
4.0	.83	-81	2.47	113	.12	44	.62	-35
5.0	.78	-96	2.27	105	.14	36	.58	-43
6.0	.75	-108	2.08	97	.15	32	.56	-52
7.0	.70	-119	1.83	87	.15	26	.55	-58
8.0	.67	-130	1.65	79	.15	19	.55	-63
9.0	.66	-140	1.49	72	.15	18	.56	-65
10.0	.64	-152	1.37	64	.15	15	.56	-67
11.0	.64	-158	1.24	59	.14	14	.54	-66
12.0	.67	-165	1.18	54	.14	13	.54	-67
13.0	.69	-168	1.11	49	.14	11	.51	-74
14.0	.69	-175	1.11	44	.14	12	.54	-80
15.0	.65	-178	.98	38	.13	9	.55	-86
16.0	.66	174	1.02	33	.14	9	.53	-90
17.0	.63	164	.96	26	.13	8	.56	-95
18.0	.64	160	.86	21	.13	9	.50	-97

$V_{ds} 3\text{ V}$, $I_{ds} 30\text{ mA}$

2.0	.90	-49	3.61	143	.07	62	.65	-24
3.0	.89	-70	3.39	130	.10	52	.61	-28
4.0	.83	-88	2.91	117	.11	44	.55	-36
5.0	.78	-103	2.63	104	.12	36	.51	-44
6.0	.75	-116	2.37	97	.13	33	.49	-53
7.0	.70	-126	2.08	87	.13	27	.49	-59
8.0	.68	-137	1.87	79	.13	22	.49	-64
9.0	.67	-148	1.67	73	.13	21	.51	-67
10.0	.65	-158	1.53	65	.12	19	.51	-68
11.0	.65	-164	1.37	60	.12	18	.49	-67
12.0	.70	-171	1.32	55	.12	18	.47	-68
13.0	.72	-174	1.23	51	.12	17	.47	-75
14.0	.74	-180	1.22	46	.13	20	.49	-81
15.0	.67	177	1.09	40	.12	17	.50	-87
16.0	.69	169	1.12	36	.12	18	.50	-90
17.0	.66	158	1.05	28	.13	18	.52	-96
18.0	.67	156	.94	24	.12	20	.56	-98

TYPICAL COMMON SOURCE SCATTERING PARAMETERS (TA = 25°C)

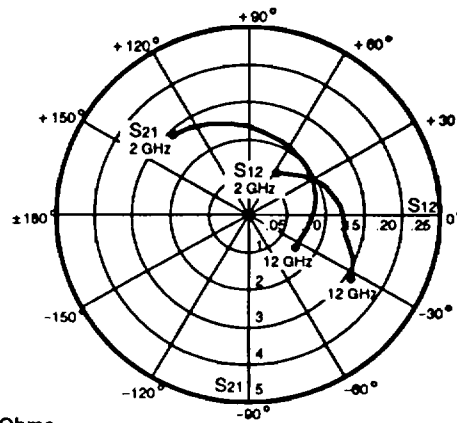
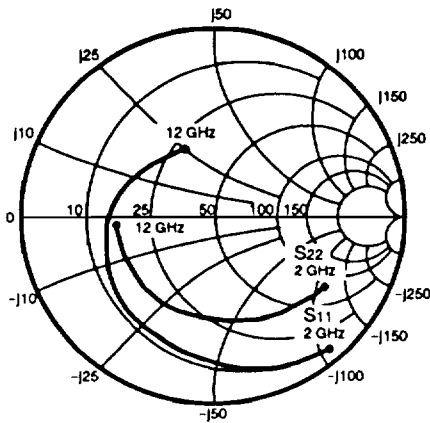

Coordinates in Ohms
Frequency in GHz
(V_{DS} = 3 V, I_{DS} = 10 mA)



NE72089A

V_{DS} = 3 V, I_{DS} = 10 mA

FREQUENCY (GHz)	S ₁₁		S ₂₁		S ₁₂		S ₂₂	
	MAG	ANG	MAG	ANG	MAG	ANG	MAG	ANG
2.0	.92	-52	2.94	130	.07	54	.68	-35
3.0	.84	-75	2.62	108	.09	38	.63	-51
4.0	.76	-95	2.34	90	.11	26	.59	-66
5.0	.71	-113	2.18	72	.12	16	.58	-79
6.0	.65	-131	2.02	56	.13	-7	.56	-93
7.0	.59	-146	1.86	41	.13	-1	.54	-105
8.0	.55	-160	1.76	26	.13	-7	.54	-116
9.0	.49	-177	1.68	13	.13	-12	.53	-129
10.0	.44	165	1.66	-1	.14	-17	.53	-139
11.0	.39	140	1.63	-19	.15	-26	.52	-154
12.0	.37	112	1.55	-34	.16	-33	.51	-170

V_{DS} = 3 V, I_{DS} = 30 mA

2.0	.89	-58	3.76	127	.06	55	.60	-35
3.0	.79	-82	3.27	105	.08	40	.56	-50
4.0	.72	-103	2.88	86	.09	31	.53	-64
5.0	.66	-121	2.61	69	.10	22	.51	-75
6.0	.60	-139	2.38	54	.11	16	.50	-86
7.0	.55	-155	2.18	38	.11	10	.50	-97
8.0	.50	-170	2.04	24	.12	6	.50	-108
9.0	.44	172	1.93	11	.12	2	.49	-118
10.0	.40	152	1.89	-3	.14	-2	.50	-126
11.0	.36	126	1.83	-20	.15	-11	.49	-138
12.0	.35	99	1.72	-36	.16	-18	.48	-151

NE720 SERIES

OUTLINE DIMENSIONS (Units in mm)

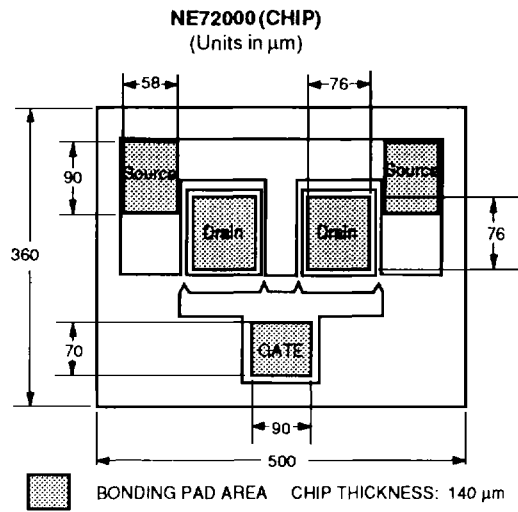

Note: All dimensions are typical unless otherwise specified.

PACKAGE OUTLINE 89A

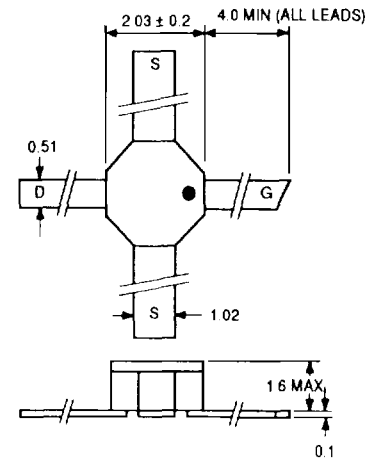

ORDERING INFORMATION

PART NUMBER	PACKAGE OUTLINE	I_{DSS} RANGE (mA)
NE72000	CHIP	Standard (30 to 150)
NE72000M	CHIP	90 to 120
NE72000N	CHIP	60 to 90
NE72000P	CHIP	30 to 60
NE72089A	89A	Standard (30 to 150)