

Timer Control for Triac and Relay

Description

The timer control circuit, U2100B, uses bipolar technology. It has different mode selections (Zero voltage switch, Phase control, Relay control). The output stage is

triggered according to input conditions. It can be used in triac application for two or three wire system as a power switch.

Features

- Adjustable and retriggerable tracking time
- Window monitoring for sensor input
- Enable input for triggering
- Internal noise suppression (40 ms) and retrigger blocking (640 ms)
- Two or three wire application

Applications

- Motion detectors
- Touch sensors
- Timer

Package: DIP8, SO8

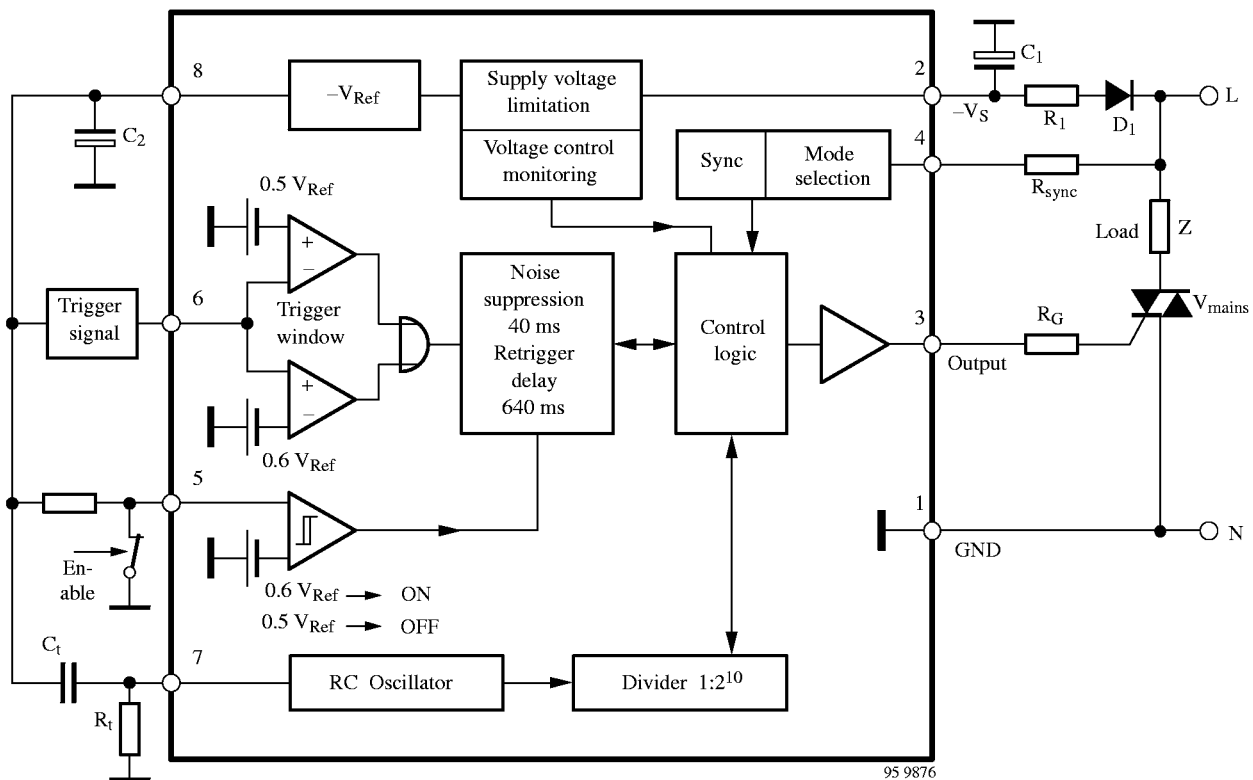
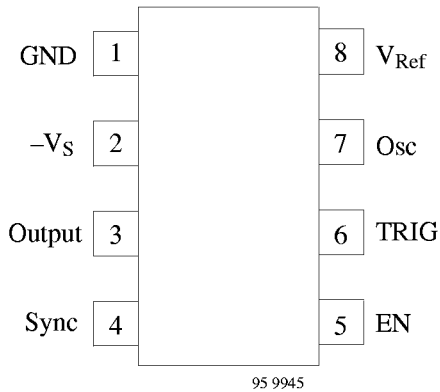

Figure 1. Block diagram with external circuit

Pin Description



Pin	Symbol	Function
1	GND	Reference point
2	$-V_S$	Supply voltage
3	Output	Driver output
4	Sync	Synchronisation and mode selection
5	EN	Enable
6	TRIG	Input trigger signal
7	Osc	RC Oscillator
8	V_{Ref}	Reference voltage

General Description

Monostable integrated power control circuit, U2100B, can be used according to mode selection in relay's or triac's applications. Beyond that, it can be used in triac-application for two wire system as power switch, (being the load in series to the switch) whereas the supply voltage for the control unit is gained from phase rest angle (α_{min} -operation).

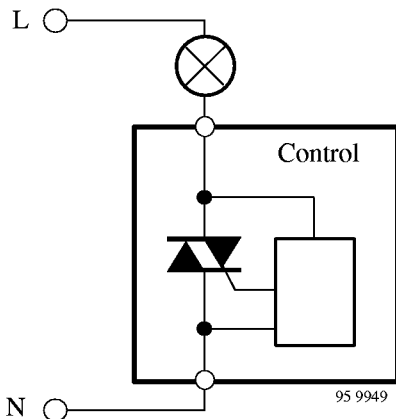

Figure 2. Two wire circuit

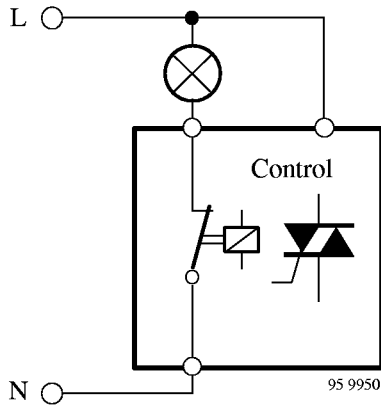

Figure 3. Three wire circuit

For three wire switch, two modes of operations are possible:

- Zero voltage switch operation for triac control
- Static operation for relay control

Mode Selection Pin 4 and Supply Voltage Pin 2

Operation modes can be selected by external voltage at the sync. input Pin 4 (clamping). Mode selection determines the current requirement of driver stage for relay's or triac's and hence the selection of supply voltage.

Zero Voltage Switch Operation, Figure 4

Selection condition:

V_4 = internal sync limitation, without external clamping

$$R_1 \approx 0.85 \frac{V_M - V_S}{2 I_{tot}}$$

$$I_{tot} = I_S + I_P + I_X$$

whereas:

I_S = Supply current of IC without load

I_P = Average trigger current I_G

I_X = External circuit current requirement

V_M = Mains voltage

Required firing pulse width t_p

$$t_p = \frac{2}{\omega} \arcsin \left(\frac{I_L \times V_M}{P \times \sqrt{2}} \right)$$

whereas:

I_L = Triac latching current

P = Power at load Z

$$R_{sync} [k\Omega] \approx \frac{V_M [V] \times \sqrt{2} \sin(\omega \times t_p [s]) - 0.7}{1.8 \times 10^{-2}} - 176$$

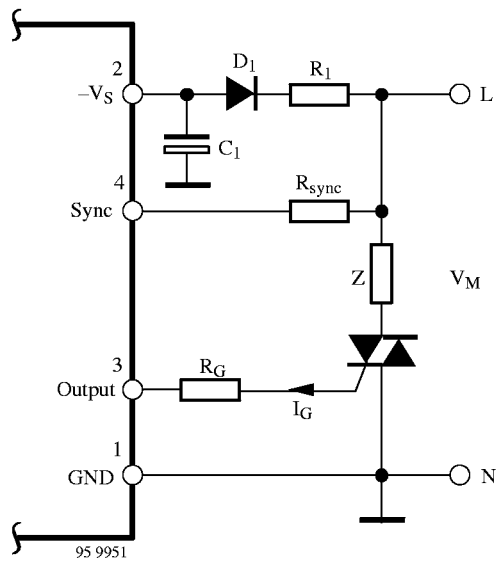

Figure 4.

α_{min} -Operation, Figure 6

Selection condition:

$$-V_4 = 6.5 \text{ to } 7.8 \text{ V} \quad +V_4 = \text{int. limitation}$$

$$R_{\alpha_{max}} = R_{sync} \frac{3.6 \text{ V}}{V_{R(\text{peak})} - 3.6 \text{ V}}$$

$$R_{\alpha_{min}} = R_{sync} \frac{10 \text{ V}}{V_M \times \sqrt{2} - 10 \text{ V}}$$

$V_{R(\text{peak})}$ is the peak voltage of the rest phase angle, which should be high enough to generate the supply voltage, V_S .

DC Operation, Figure 5

Selection condition:

$$+V_4 = 6.1 \text{ V} \quad -V_4 = \text{int. limitation}$$

whereas:

$$R_o \approx 1/10 X_c$$

$$X_c = 0.85 \frac{V_M - V_S}{I_{tot}}$$

$$I_{tot} = I_S + I_{Rel} + I_X$$

$$C_o = \frac{1}{\omega \times X_c}$$

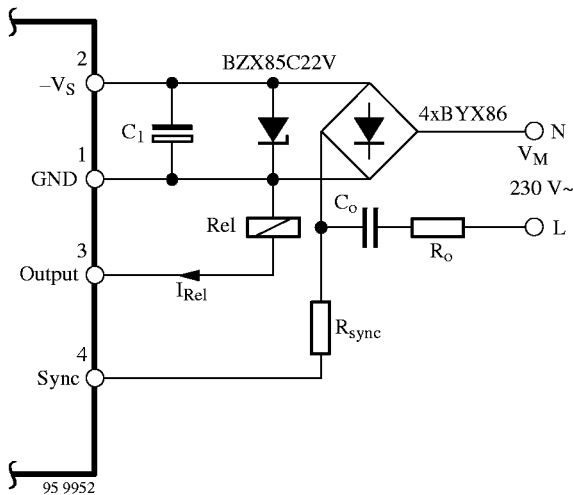

Figure 5.

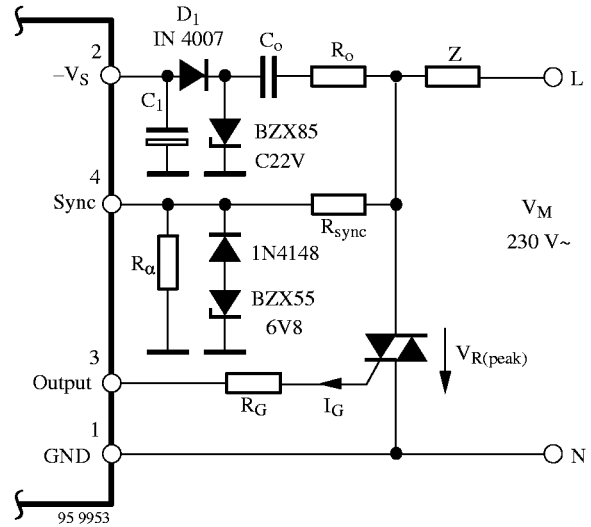

Figure 6.

- $C_1 = 100 \mu\text{F}/35 \text{ V}$
- $C_o = 0.33 \mu\text{F}/250 \text{ V}\sim$
- $R_o = 390 \Omega$
- $R_{sync} = 220 \text{ k}\Omega$
- $R_\alpha = 10 \text{ k}\Omega$
- $R_G = 390 \Omega$
- $D_1 = \text{IN } 4007$

Tracking Time Pin 7

An internal RC oscillator with following divider stage $1:2^{10}$ allows a very long and reproducible tracking time.

RC-values for required final time, t_t , can be calculated as follows:

$$R_t[\Omega] = \frac{t_t[s] \cdot 10^6}{1.6 \cdot 1024 \cdot C_t[\mu F]}$$

$$C_t[\mu F] = \frac{t_t[s] \cdot 10^6}{1.6 \cdot 1024 \cdot R_t[\Omega]}$$

$$t_t[s] = \frac{C_t[\mu F] \times R_t[\Omega] \times 1.6 \times 1024}{10^6}$$

Trigger Inputs Pins 5 and 6, Figures 7 and 8

Two AND-connected, identical inputs determine the trigger conditions of monostable time stages, i.e., both inputs must be in position "ON" so that the output is switched ON. The tracking time starts after the trigger conditions has elapsed. The output ON state is given until the tracking time is over.

Input Pin 5 is a simple comparator whereas input Pin 6 is built up as a window discriminator.

Noise suppression for $t_{ON} = 40$ ms guarantee, that there is no peak noise signals at the inputs which could trigger the circuit.

At the same time, the retrigger is delayed for a duration of 640 ms (t_{OFF}), to avoid noise signal to trigger the relay.

Absolute Maximum Ratings

Reference point Pin 1, unless otherwise specified

Parameters	Symbol	Value	Unit
Supply Pin 2			
Supply current	$-I_S$	10	mA
Peak current $t \leq 10 \mu s$	$-i_s$	60	mA
Supply voltage	$-V_S$	32	V
Reference voltage source Pin 8			
Output current	I_O	3	mA
Synchronization Pin 4			
Input current	$\pm I_{Sync.}$	5	mA
$t \leq 10 \mu s$	$i_{Sync.}$	20	mA
Window monitoring			
Input voltage	$-V_1$	V_{Ref} to 0	V
Enable-Schmitt trigger Pin 5			
Input voltage	$-V_1$	V_{Ref} to 0	V
Driver output Pin 3			
Collector voltage	$-V_o$	V_S to 2	V
Storage temperature range	T_{stg}	-40 to +125	°C
Junction temperature	T_j	125	°C
Ambient temperature range	T_{amb}	0 to 100	°C

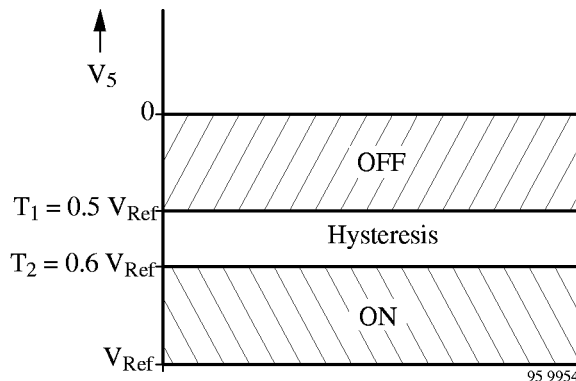

Figure 7. Trigger condition, Pin 5

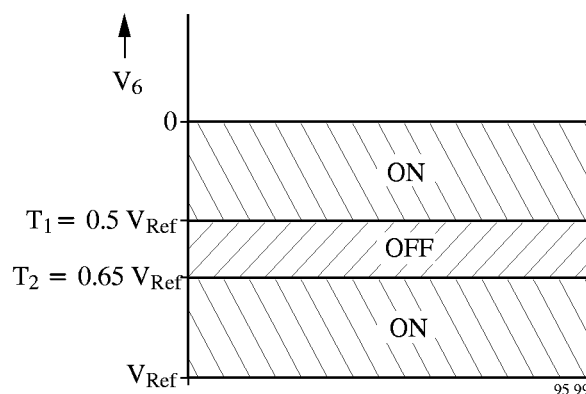

Figure 8. Trigger condition, Pin 6

Thermal Resistance

Parameters	Symbol	Value	Unit
Junction ambient DIP8	R_{thJA}	110	K/W
SO8 on PC board	R_{thJA}	220	K/W
SO8 on ceramic	R_{thJA}	140	K/W

Electrical Characteristics

$V_S = -18\text{ V}$, $T_{amb} = 25^\circ\text{C}$, reference point Pin 1, unless otherwise specified

Parameters	Test Conditions / Pins	Symbol	Min	Typ	Max	Unit
Supply voltage limitation	$I_S = 800\ \mu\text{A}$ Pin 2	$-V_S$	21		23	V
	$I_S = 2\ \text{mA}$		21.3		24	V
Current consumption	$I_3 = 0$	$-I_S$			750	μA
Supply voltage monitoring Pin 2						
ON-Threshold		$-V_S$		15		V
OFF-Threshold		$-V_S$		6.5		V
Reference voltage	$I_8 = 0.1\ \text{mA}$ Pin 8	$-V_{Ref}$	4.75		5.25	V
	$I_8 = 1.5\ \text{mA}$		4.55		5.25	V
Synchronization Pin 4						
Input current		$\pm i_{sync}$	0.1		1.1	mA
Voltage limitation	$I_4 = \pm 1\ \text{mA}$	$\pm V_{sync}$	8.8	9.4	10	V
Rest phase angle	ON	$\pm V_T$	3.6	4	4.4	V
α_{min} -threshold	Off	$\pm V_T$	1.8	2	2.2	V
Zero-identification Pin 4						
Zero-identification	ON	$\pm V_T$		1.5		V
		$\pm I_T$		8.5		μA
	OFF	$\pm V_T$		4		V
		$\pm I_T$		20		μA
Operation selection Pin 4						
Zero voltage switch		$\pm V_{sync}$		V_4 limit		
α_{min} -operation		$+V_{sync}$		V_4 limit		V
		$-V_{sync}$		6.5 to 7.8		V
DC mode		$-V_{sync}$		V_4 limit		V
		$+V_{sync}$		6.5 to 7.8		V
Window monitoring figure 4 Pin 6						
Threshold 1		$-V_I/V_{Ref}$	0.52	0.49	0.46	
Threshold 2		$-V_I/V_{Ref}$	0.67	0.65	0.63	
Enable-Schmitt trigger Pin 5						
Threshold 1	OFF	$-V_I/V_{Ref}$	0.33	0.3	0.27	
Threshold 2	ON	$-V_I/V_{Ref}$	0.62	0.6	0.58	
Oscillator $f = \frac{1}{1.6 \times R_t \times C_t}$						
Threshold 1	Pin 7 – 1	V_I/V_{Ref}	0.25	0.20	0.15	
Threshold 2	Pin 7 – 8	V_I		100	200	mV
Input current	Pin 7	I_I		100	500	nA
Output stage limiter diode w.r.t. Pin 1 Pin 3						
Saturation voltage	$I_3 = 100\ \text{mA}$	V_{3-2}			2	V
Output current		I_3	100			mA

Applications

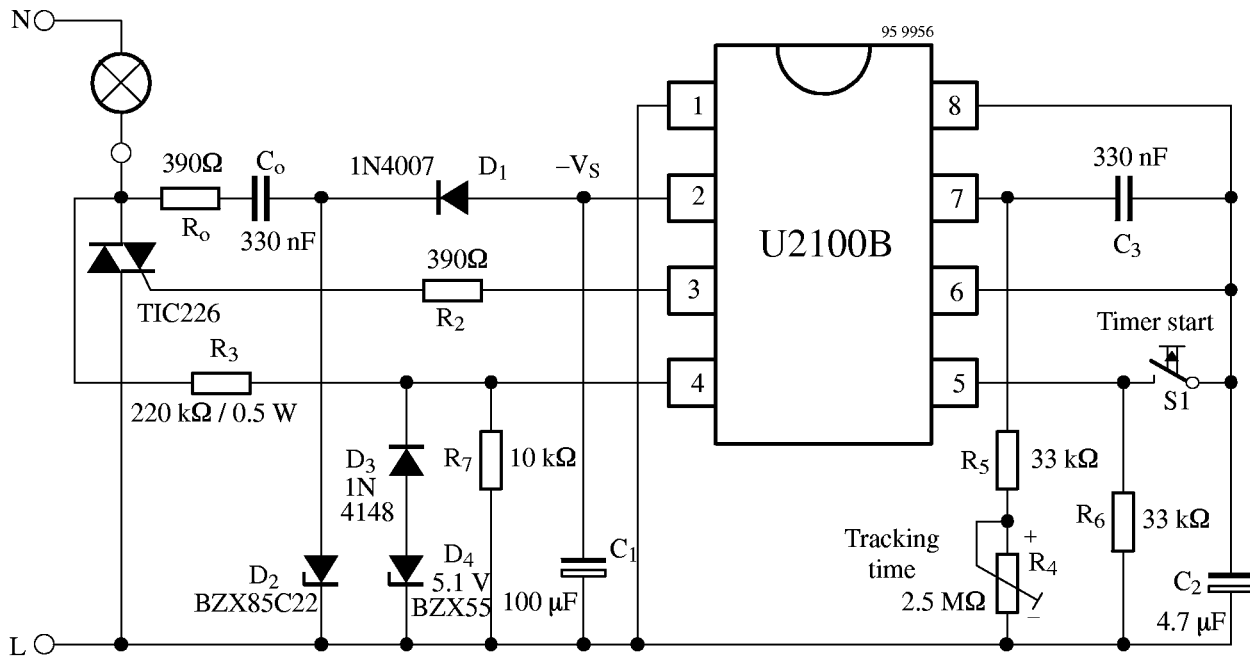

Figure 9. Lamp time control 18 sec. to 23 min. for two wire systems

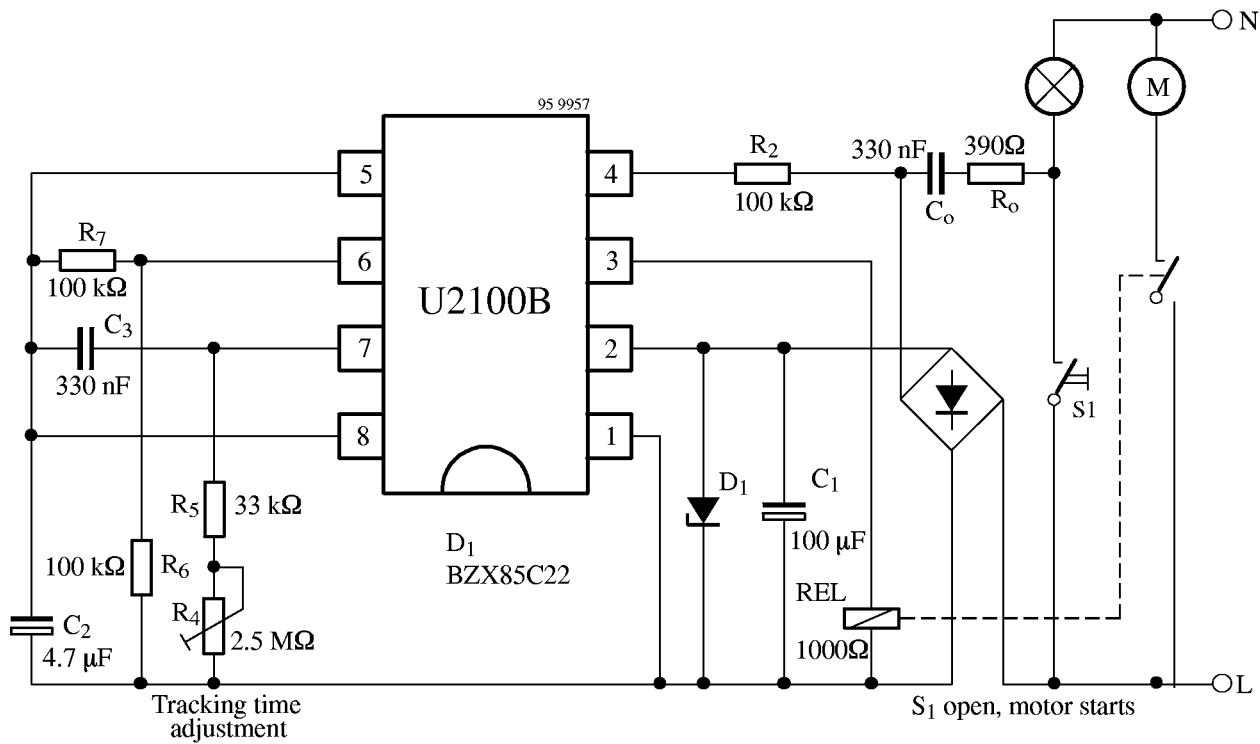
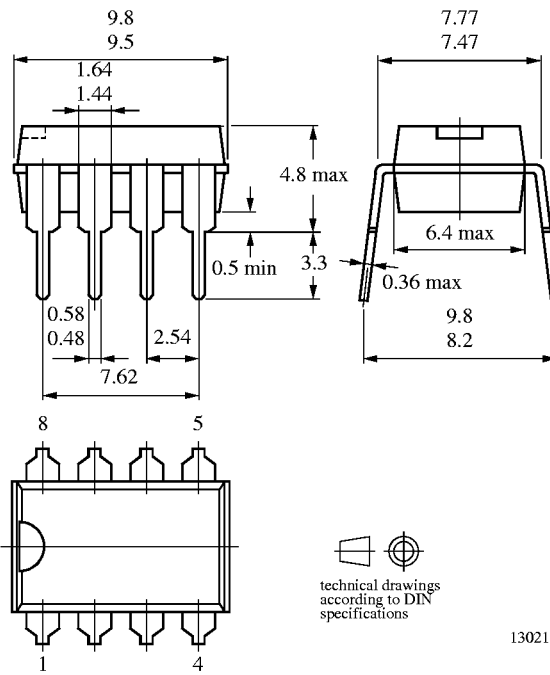

Figure 10. Fan tracking time control 18 sec. to 23 min.

Package Information

Package DIP8
Dimensions in mm



Package SO8
Dimensions in mm

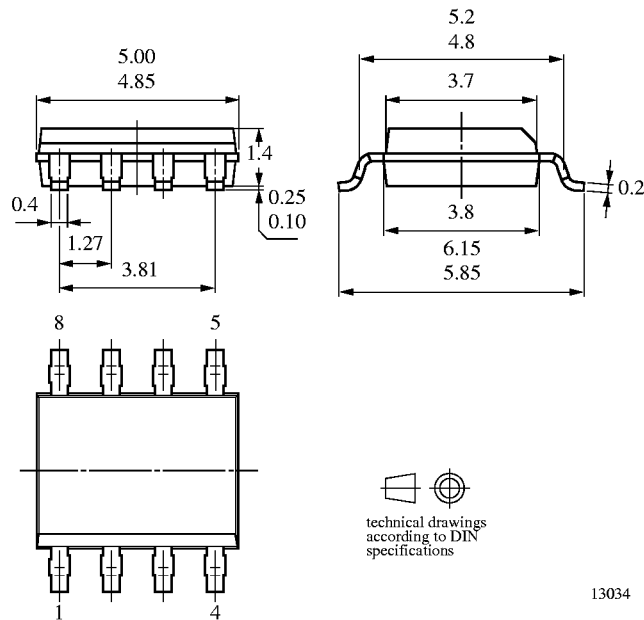

Ozone Depleting Substances Policy Statement

It is the policy of **TEMIC Semiconductor GmbH** to

1. Meet all present and future national and international statutory requirements.
2. Regularly and continuously improve the performance of our products, processes, distribution and operating systems with respect to their impact on the health and safety of our employees and the public, as well as their impact on the environment.

It is particular concern to control or eliminate releases of those substances into the atmosphere which are known as ozone depleting substances (ODSs).

The Montreal Protocol (1987) and its London Amendments (1990) intend to severely restrict the use of ODSs and forbid their use within the next ten years. Various national and international initiatives are pressing for an earlier ban on these substances.

TEMIC Semiconductor GmbH semiconductor division has been able to use its policy of continuous improvements to eliminate the use of ODSs listed in the following documents.

1. Annex A, B and list of transitional substances of the Montreal Protocol and the London Amendments respectively
2. Class I and II ozone depleting substances in the Clean Air Act Amendments of 1990 by the Environmental Protection Agency (EPA) in the USA
3. Council Decision 88/540/EEC and 91/690/EEC Annex A, B and C (transitional substances) respectively.

TEMIC Semiconductor GmbH can certify that our semiconductors are not manufactured with ozone depleting substances and do not contain such substances.

We reserve the right to make changes to improve technical design and may do so without further notice.

Parameters can vary in different applications. All operating parameters must be validated for each customer application by the customer. Should the buyer use TEMIC products for any unintended or unauthorized application, the buyer shall indemnify TEMIC against all claims, costs, damages, and expenses, arising out of, directly or indirectly, any claim of personal damage, injury or death associated with such unintended or unauthorized use.

TEMIC Semiconductor GmbH, P.O.B. 3535, D-74025 Heilbronn, Germany
Telephone: 49 (0)7131 67 2831, Fax number: 49 (0)7131 67 2423