

# TDA1170 • TDA1270

## TV VERTICAL DEFLECTION SYSTEMS

### FAIRCHILD LINEAR INTEGRATED CIRCUIT

02/14/26

**GENERAL DESCRIPTION** – The TDA1170 and TDA1270 are monolithic integrated circuits designed for use in TV vertical deflection systems. They are manufactured using the Fairchild Planar\* process.

Both devices are supplied in the 12-pin plastic power package with the heat sink fins bent for insertion into the printed circuit board.

The TDA1170 is designed primarily for large and small screen black and white TV receivers and industrial TV monitors. The TDA1270 is designed primarily for driving complementary vertical deflection output stages in color TV receivers and industrial monitors.

- VERTICAL OSCILLATOR
- VOLTAGE RAMP GENERATOR
- HIGH GAIN POWER AMPLIFIER
- FLYBACK GENERATOR (TDA1170)

#### ABSOLUTE MAXIMUM RATINGS

	TDA1170	TDA1270	UNITS
Supply Voltage (Pin 2)	27	40	V
Supply Voltage (Pin 5)	–	40	V
Flyback Voltage (Pin 4 – Pin 5)	58	–	V
Voltage at Pin 4	–	41	V
Sync Input Voltage (Pin 8)	±12	±12	V
Power Amplifier Input Voltage	–0.5 to +10	–0.5 to +10	V
Output Peak Current (Non-Repetitive $t \leq 2$ ms)	2.0	2.0	A
Output Peak Current	$f = 50$ Hz, $t \leq 10$ $\mu$ s	2.5	A
	$f = 50$ Hz, $t > 10$ $\mu$ s	1.5	A
Power Dissipation	$T_{tab} = 90^\circ$ C	5.0	W
	$T_A = 80^\circ$ C (free air)	1.0	W
Storage Temperature Range	–40 to +150	–40 to +150	$^\circ$ C
Pin Temperature (Soldering 10 s)	260	260	$^\circ$ C

$T_J = 150^\circ$ C MAX

#### THERMAL DATA

$\theta_{J-C}$  Thermal Resistance Junction to Tab (max) 12 $^\circ$ C/W  
 $\theta_{J-A}$  Thermal Resistance Junction to Ambient (max) 70 $^\circ$ C/W†

†Obtained with tabs soldered to printed circuit with minimized area.

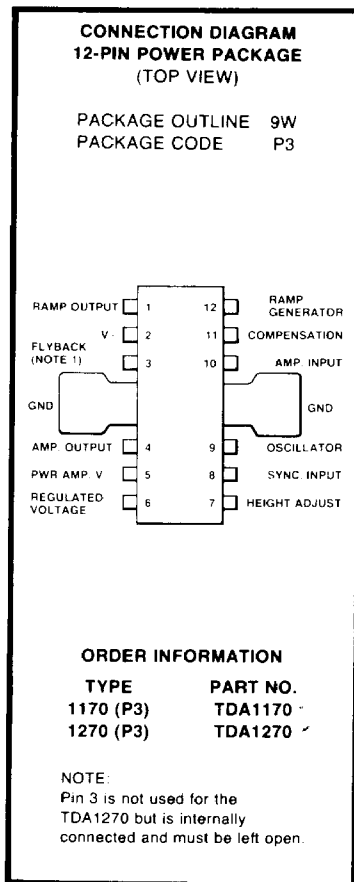

\*Planar is a patented Fairchild process.

BLOCK DIAGRAMS

TDA1170

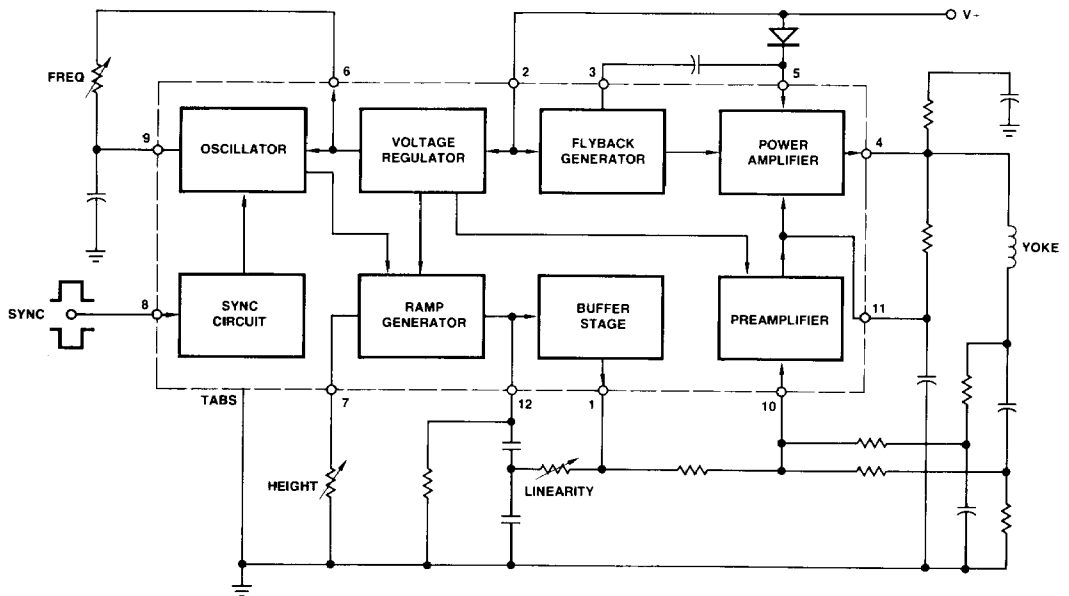

TDA1270

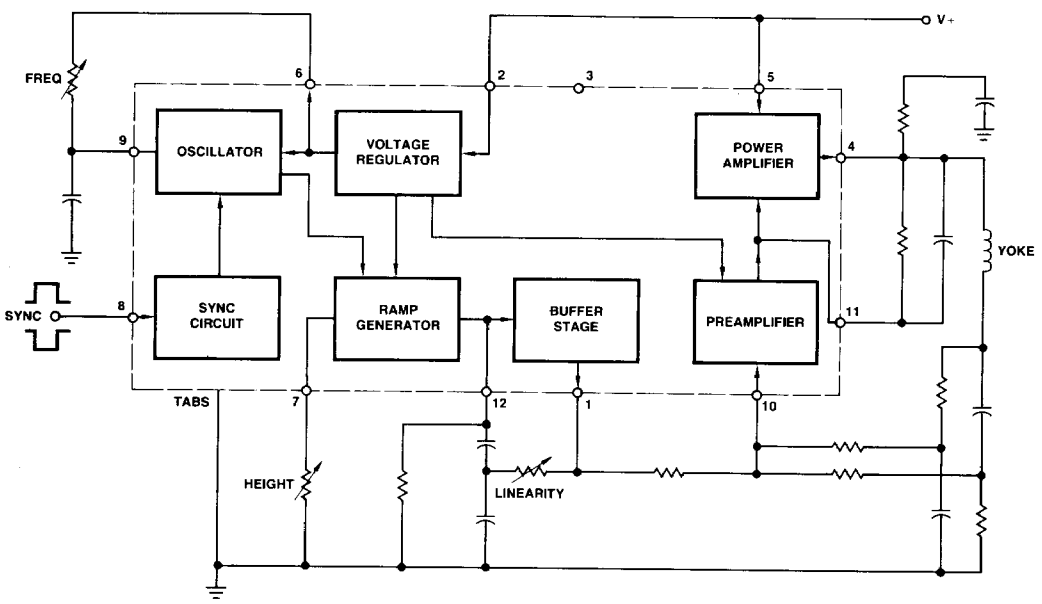

EQUIVALENT CIRCUIT

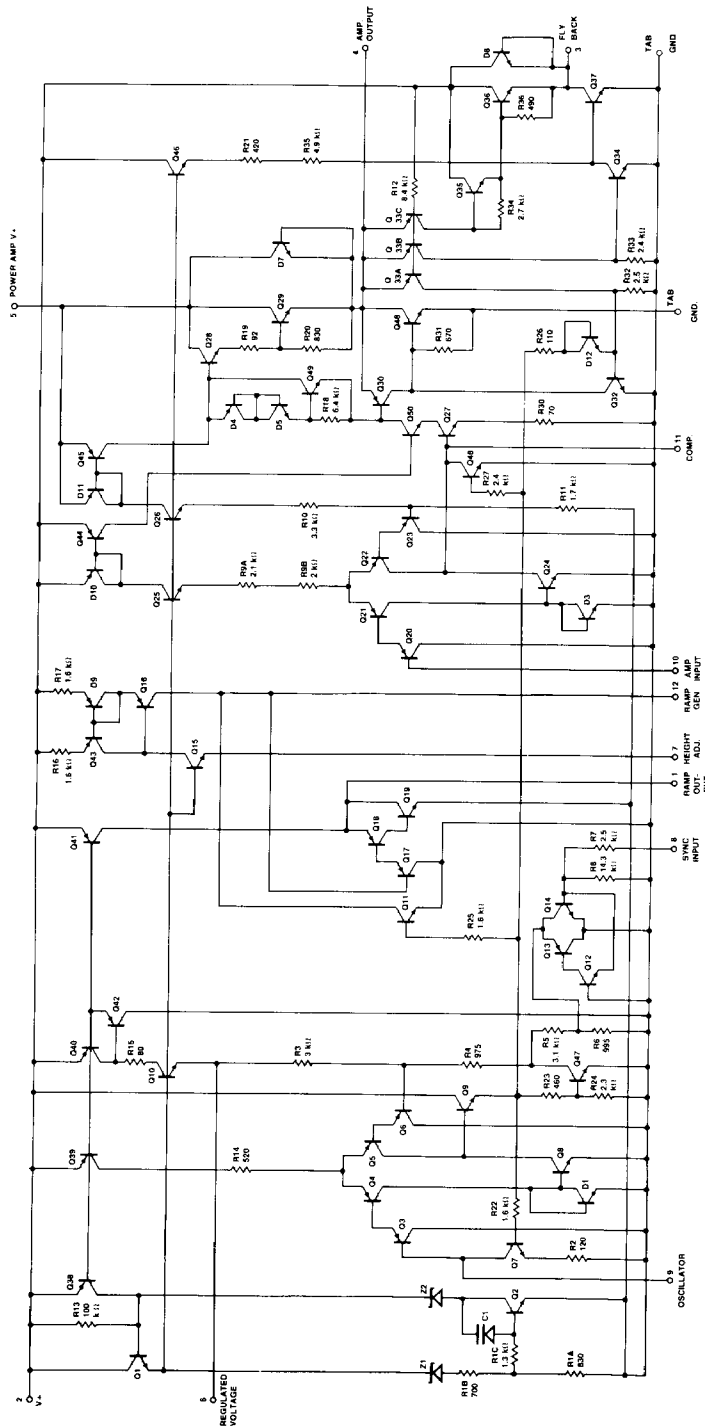

TDA1170

EQUIVALENT CIRCUIT

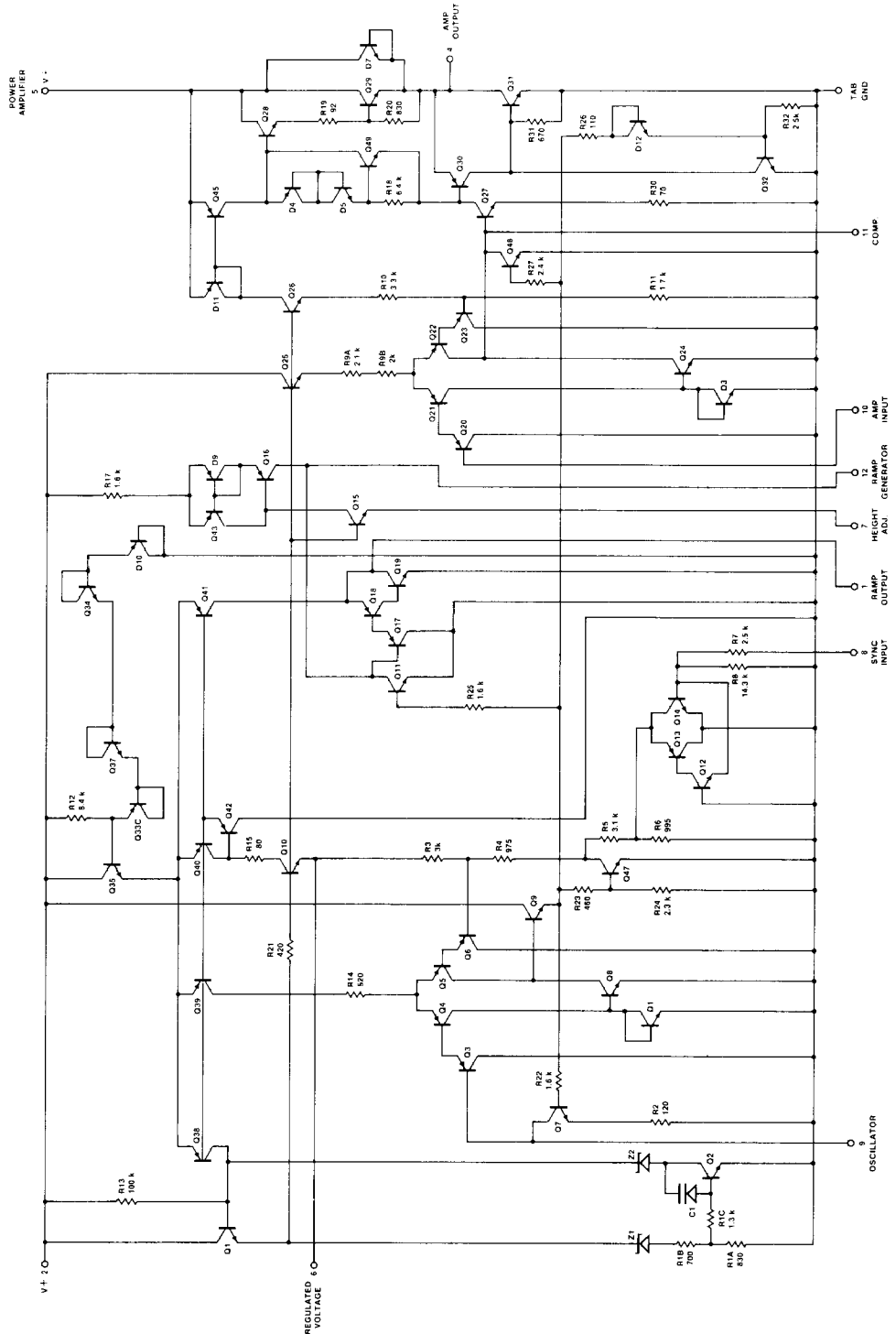

TDA1270

**ELECTRICAL CHARACTERISTICS:** (Refer to test circuits;  $T_A = 25^\circ\text{C}$ ;  $V_+ = 25\text{ V}$  (TDA1170);  $V_+ = 32\text{ V}$  (TDA1270) unless otherwise noted.)

**DC CHARACTERISTICS** (Test Circuits – Figures 1a, 1b).

CHARACTERISTICS	CONDITIONS	TDA1170			TDA1270			UNITS
		MIN	TYP	MAX	MIN	TYP	MAX	
Oscillator Bias Current	$V_g = 1\text{ V}$		0.2	1.0		0.2	1.0	$\mu\text{A}$
Amplifier Input Bias Current	$V_{10} = 1\text{ V}$		0.15	1.0		0.15	1.0	$\mu\text{A}$
Ramp Generator Bias Current			0.05	0.5		0.05	0.5	$\mu\text{A}$
Supply Voltage		10			10			V
Quiescent Output Voltage	$R_2 = 10\text{ k}\Omega$							V
	$V_+ = 25\text{ V}, R_1 = 30\text{ k}\Omega$ $V_+ = 10\text{ V}, R_1 = 10\text{ k}\Omega$	8.0 4.0	8.8 4.4	9.6 4.8				V V
Quiescent Output Voltage	$R_2 = 10\text{ k}\Omega$							V
	$V_+ = 32\text{ V}, R_1 = 30\text{ k}\Omega$ $V_+ = 10\text{ V}, R_1 = 10\text{ k}\Omega$				8.0 4.0	8.8 4.4	9.6 4.8	V V
Regulated Voltage $V_6, V_7$		6.0	6.5	7.0	6.0	6.5	7.0	V
$\frac{\Delta V_6}{\Delta V_+} \frac{\Delta V_7}{\Delta V_+}$ Line regulation	$V_+ = 10\text{ to }27\text{ V}$		1.5					mV/V
$\frac{\Delta V_6}{\Delta V_+} \frac{\Delta V_7}{\Delta V_+}$ Line regulation	$V_+ = 10\text{ to }40\text{ V}$					1.5		mV/V

**AC CHARACTERISTICS** (Test Circuits – Figures 2a, 2b)

Supply Current	$I_Y = 0.5\text{ A}$					70		mA
	$I_Y = 1\text{ A}$		140					mA
Peak to Peak Yoke Current (Pin 4)				1.6			1.0	A
Flyback Voltage	$I_Y = 1\text{ A}$		51					V
Peak Sync. Input Voltage (Positive or Negative)		1.0			1.0			Vpk
Peak to Peak Oscillator Sawtooth Voltage			2.4			2.4		Vpk-pk
Sync. Input Resistance	$V_g = 1\text{ V}$		3.5			3.5		$\text{k}\Omega$
Flyback Time	$I_Y = 1\text{ A}$		0.6	0.8				
	$I_Y = 0.5\text{ A}$					0.7		ms
Pull-in Range (Below 50 Hz)			7.0			7.0		Hz
Oscillator Frequency Drift with Supply Voltage	$V_+ = 10\text{ to }40\text{ V}$					0.01		$\frac{\text{Hz}}{\text{V}}$
	$V_+ = 10\text{ to }27\text{ V}$		0.01					
Oscillator Frequency Drift with Tab Temperature	$T_{\text{tab}} = 40\text{ to }120^\circ\text{C}$		0.015			0.015		$\frac{\text{Hz}}{^\circ\text{C}}$

4

TYPICAL PERFORMANCE CURVES – TDA1170

RELATIVE CHANGE IN QUIESCENT VOLTAGE AS A FUNCTION OF SUPPLY VOLTAGE

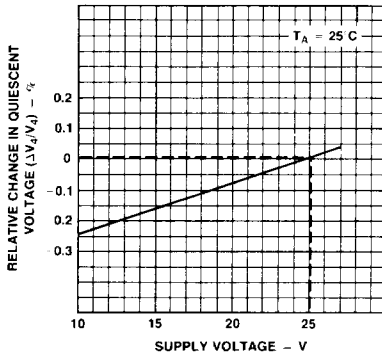

RELATIVE CHANGE IN QUIESCENT VOLTAGE AS A FUNCTION OF TAB TEMPERATURE

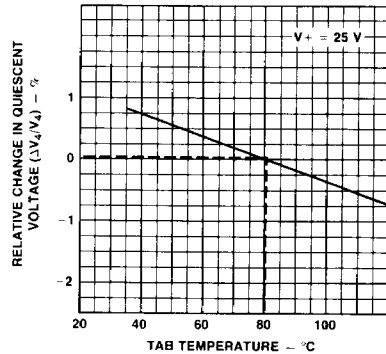

REGULATED VOLTAGE ( $V_6, V_7$ ) AS A FUNCTION OF SUPPLY VOLTAGE

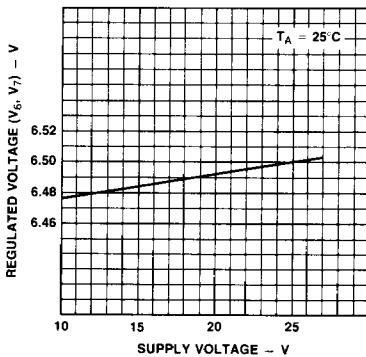

REGULATED VOLTAGE ( $V_6, V_7$ ) AS A FUNCTION OF TAB TEMPERATURE

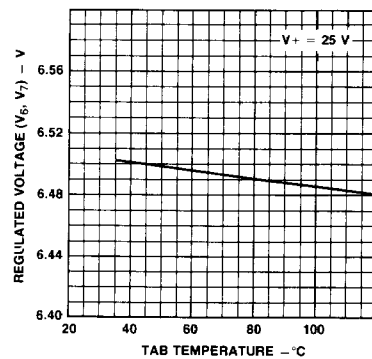

FREQUENCY VARIATION OF UNSYNCHRONIZED OSCILLATOR AS A FUNCTION OF SUPPLY VOLTAGE

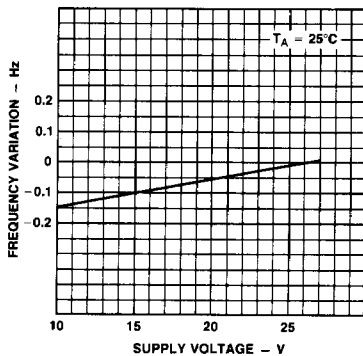

FREQUENCY VARIATION OF UNSYNCHRONIZED OSCILLATOR AS A FUNCTION OF TAB TEMPERATURE

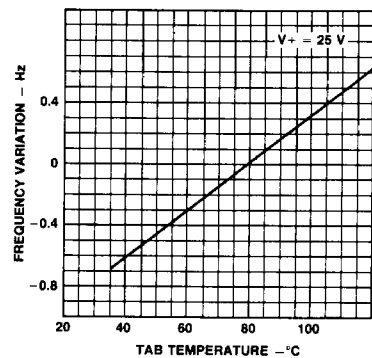

TYPICAL PERFORMANCE CURVES – TDA1270

RELATIVE CHANGE IN QUIESCENT VOLTAGE AS A FUNCTION OF SUPPLY VOLTAGE

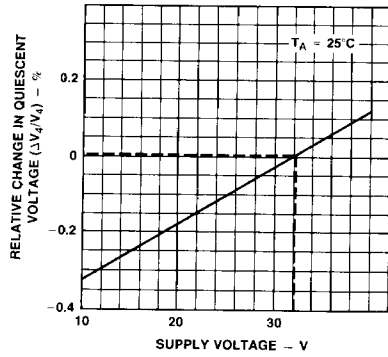

RELATIVE CHANGE IN QUIESCENT VOLTAGE AS A FUNCTION OF TAB TEMPERATURE

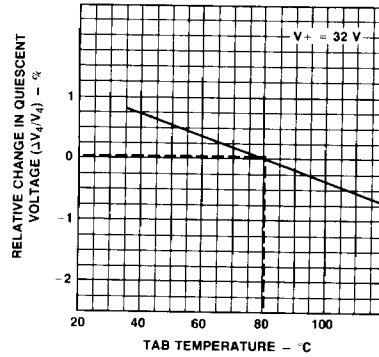

REGULATED VOLTAGE ( $V_6, V_7$ ) AS A FUNCTION OF SUPPLY VOLTAGE

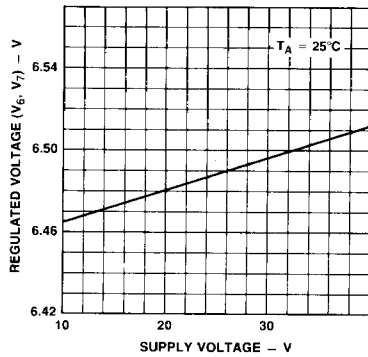

REGULATED VOLTAGE ( $V_6, V_7$ ) AS A FUNCTION OF TAB TEMPERATURE

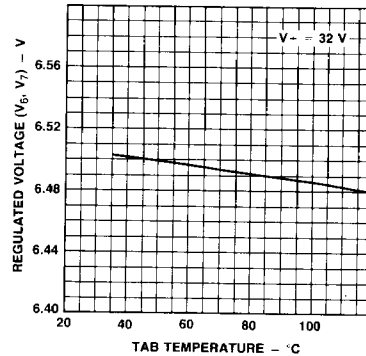

FREQUENCY VARIATION OF UNSYNCHRONIZED OSCILLATOR AS A FUNCTION OF SUPPLY VOLTAGE

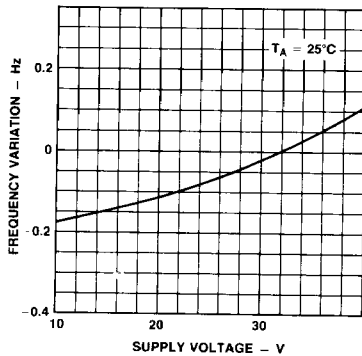

FREQUENCY VARIATION OF UNSYNCHRONIZED OSCILLATOR AS A FUNCTION OF TAB TEMPERATURE

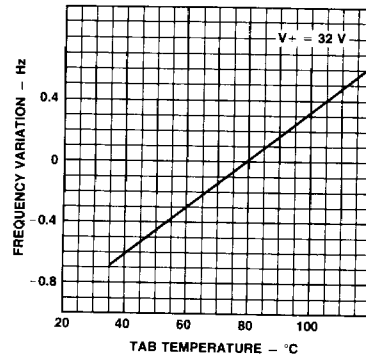

**APPLICATION INFORMATION (TDA1170)**

The vertical oscillator is directly synchronized by the sync pulses (positive or negative); therefore its free running frequency must be lower than the sync frequency. The use of current feedback causes the yoke current to be independent of yoke resistance variations due to thermal effects. Therefore no thermistor is required in series with the yoke. The flyback generator applies a voltage, about twice the supply voltage, to the yoke. This produces a short flyback time together with a high useful power to dissipated power ratio.

$$t_{fly} \approx \frac{2 L_Y I_Y}{3V+}$$

where:  $L_Y$  = Yoke inductance (mH)  
 $V+$  = Supply Voltage (V)  
 $I_Y$  = Peak to peak yoke current (A)

The supply current is :  $I+ \approx \frac{I_Y}{8} + 0.02$

As can be seen, the supply current is independent of  $V+$  and depends only on the yoke characteristics. The minimum value of  $V+$  necessary for the required output current results in the maximum efficiency. The quiescent output voltage (pin 4) is fixed by the voltage feedback net network R7, R8, and R9 (Fig. 2a) according to:

$$V_4 = V_{10} \frac{R7 + R8 + R9}{R7}$$

The voltage on the inverting input of the amplifier ( $V_{10}$ ) is  $V_{10} \approx 2 V$ . Typical application circuits are shown in Figures 3 and 4. A printed circuit board layout is shown in Figure 5.

**TEST CIRCUITS**

**STATIC TEST CIRCUIT FOR MEASUREMENT OF  $-I_g$ ,  $-I_{12}$ , AND  $V_4$**

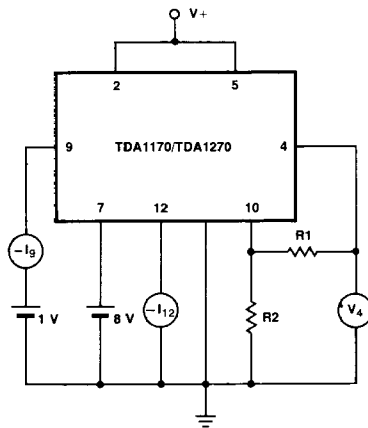

**Fig. 1a**

**STATIC TEST CIRCUIT FOR MEASUREMENT OF  $-I_{10}$ ,  $V_6$ ,  $V_7$ ,  $\Delta V_6/\Delta V+$  AND  $\Delta V_7/\Delta V+$**

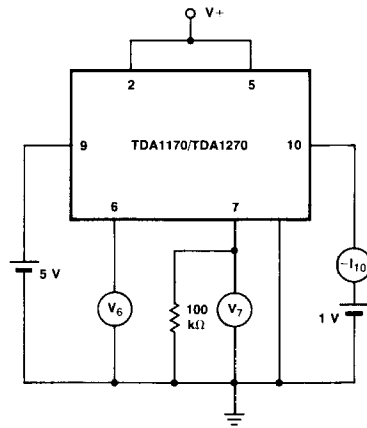

**Fig. 1b**



DYNAMIC TEST CIRCUIT FOR TDA1170

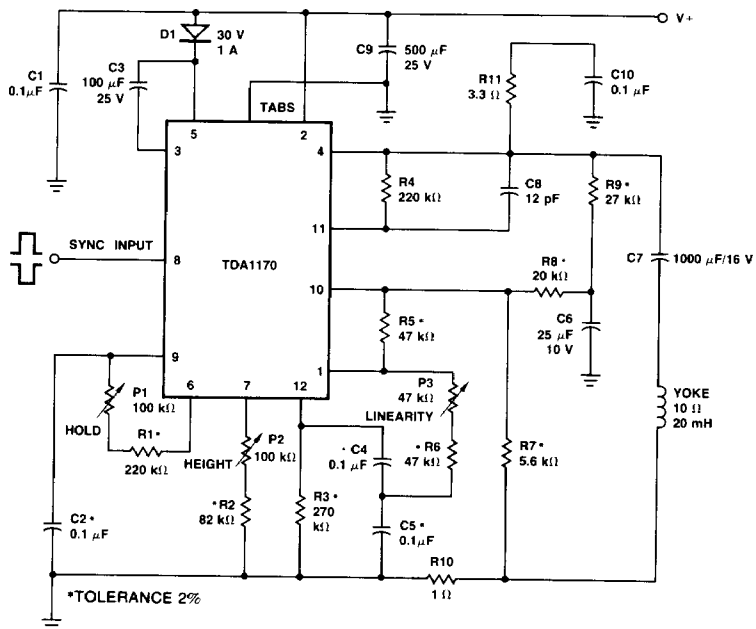

Fig. 2a

DYNAMIC TEST CIRCUIT FOR TDA1270.

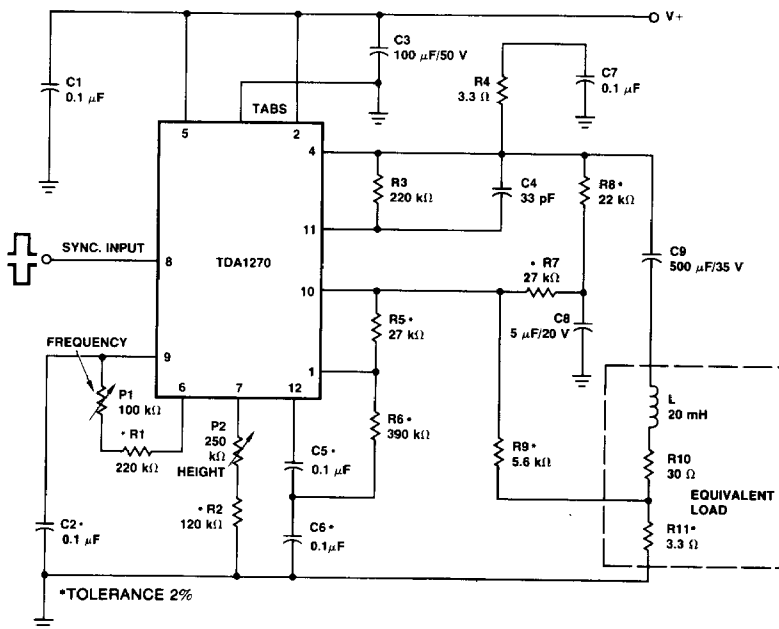

Fig. 2b

TYPICAL APPLICATION CIRCUIT FOR B & W 24" 110° TV SETS

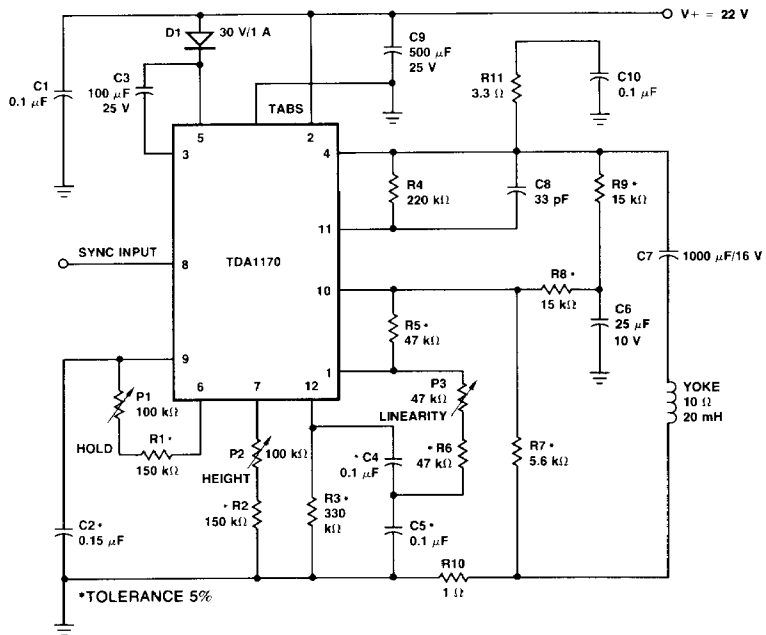

Fig. 3

Typical performance of circuit in Fig. 3 ( $V_+ = 22\text{ V}$ ;  $I_Y = 1\text{ A}$ ;  $R_Y = 10\ \Omega$ ;  $L_Y = 20\text{ mH}$ )

$I_+$	Supply current	140	mA
$t_{fly}$	Flyback time	0.75	ms
$I_Y$	Maximum scanning current (peak to peak)	1.2	A
$V_+$	Operating supply voltage	20 to 24	V
$P_D$	TDA1170 power dissipation	2.2	W

For safe working up to  $T_A = 50^\circ\text{C}$  a heatsink of  $\theta = 40^\circ\text{C/W}$  is required and each tab of the TDA1170 must be soldered to 1 cm<sup>2</sup> copper area of the printed circuit board.

TYPICAL APPLICATION CIRCUIT FOR B & W SMALL SCREEN TV SETS.

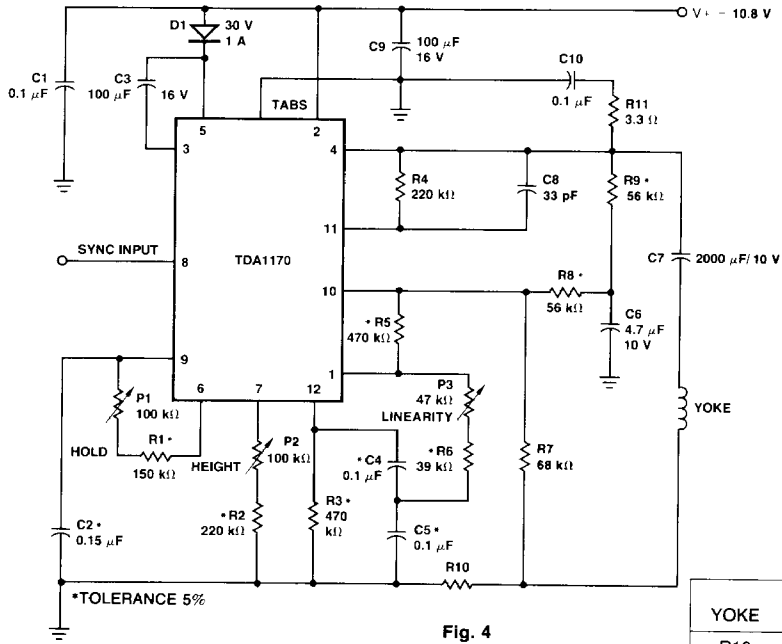

Fig. 4

Typical performance of circuit in Fig. 4 ( $V_+ = 10.8\text{ V}$ ;  $I_Y = 1\text{ A}$ ;  $R_Y = 4\ \Omega$ ;  $L_Y = 7.5\text{ mH}$ )

$I_+$	Supply current	150	mA
$t_{fly}$	Flyback time	0.7	ms
$I_Y$	Maximum scanning current (peak to peak)	1.15	A
$V_+$	Operating supply voltage	10.8	V
$P_D$	TDA1170 power dissipation	1.3	W

For safe working up to  $T_A = 50^\circ\text{C}$  a heatsink of  $\theta = 30^\circ\text{C/W}$  is required and each tab of the TDA1170 must be soldered to  $1\text{ cm}^2$  copper area of the printed circuit board.

PC BOARD AND COMPONENT LAYOUT FOR THE CIRCUIT OF FIG. 3 AND FIG. 4 (1:1 SCALE)

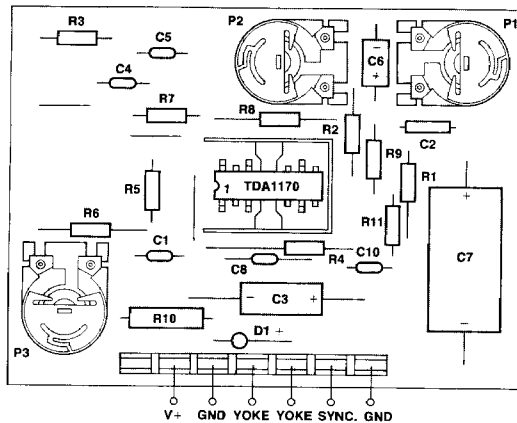

Fig. 5

C9 is not mounted on the PC board.

**APPLICATIONS INFORMATION (TDA1270)**

The high current capability of the TDA1270 allows low current gain transistors to be used in driving low impedance yokes. The oscillator is directly synchronized by the sync pulses; therefore its free frequency must be lower than the sync. frequency. The sync. input (pin 8) can be driven by positive or negative pulses.

The quiescent output voltage ( $V_4$ ) is fixed by the voltage feedback network, R7, R8, and R9 (Fig. 6) according to:

$$V_4 = V_{10} \frac{R7 + R8 + R9}{R9}$$

The voltage on the inverting input of the amplifier,  $V_{10}$ , is  $V_{10} \cong 2\text{ V}$ . Typical application circuits are shown in Fig. 6, 8, 10. Printed circuit board layouts are shown in Fig. 7 and 9.

**TYPICAL APPLICATION CIRCUIT FOR LARGE SCREEN COLOR TV SETS**

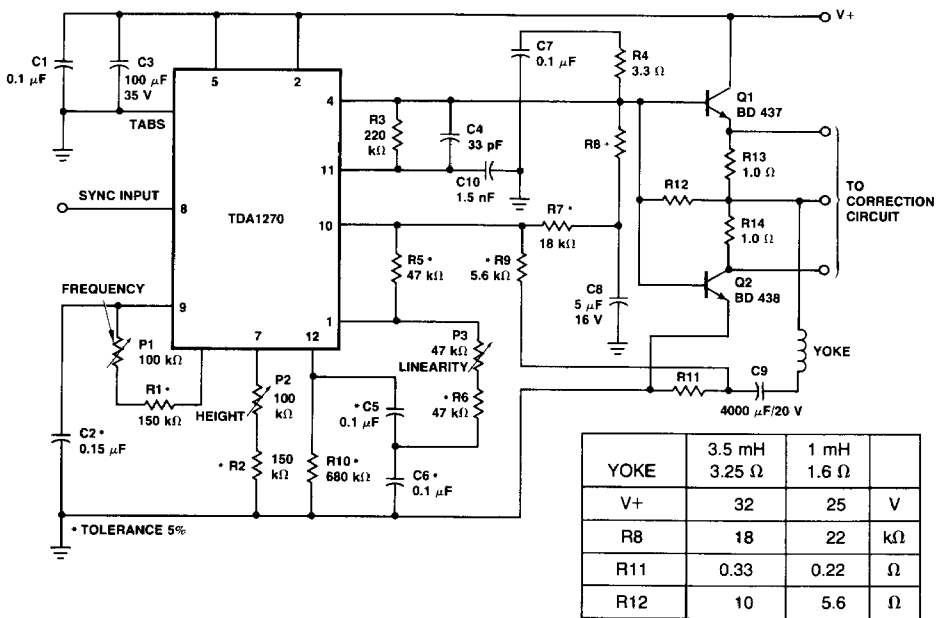

Fig. 6

- I+ Supply Current
- t<sub>fly</sub> Flyback Time
- I<sub>y</sub> Maximum Scanning Current (Peak to Peak)
- V+ Operating Supply Voltage
- P<sub>T</sub> TDA1270 Power Dissipation
- P<sub>T</sub> Output Transistors Power Dissipation
- θ<sub>tab-amb</sub> Heatsink θ Required for TDA1270
- θ<sub>case-amb</sub> θ of Output Transistors Heatsink (Total)

YOKE	
3.5 mH	1 mH
3.25 Ω	1.6 Ω
0.5 A	0.8 A
0.7 ms	0.6 ms
4 A	7.5 A
28 to 36 V	23 to 27 V
1.5 W	2.0 W
11 W	13 W
35°C/W	30°C/W
6°C/W	5°C/W

Stable continuous operation is ensured up to an ambient temperature of 55°C

PC BOARD AND COMPONENT LAYOUT FOR THE CIRCUIT OF FIG. 6 (1:1 SCALE)

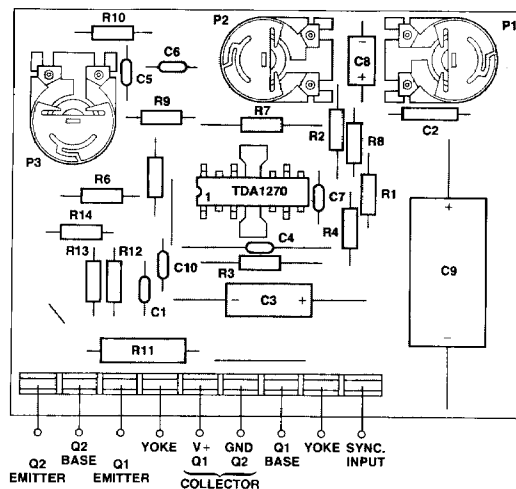

Fig. 7

TYPICAL APPLICATION CIRCUIT FOR 12" TO 17" (110°, 20 mm NECK) B & W TV SET.

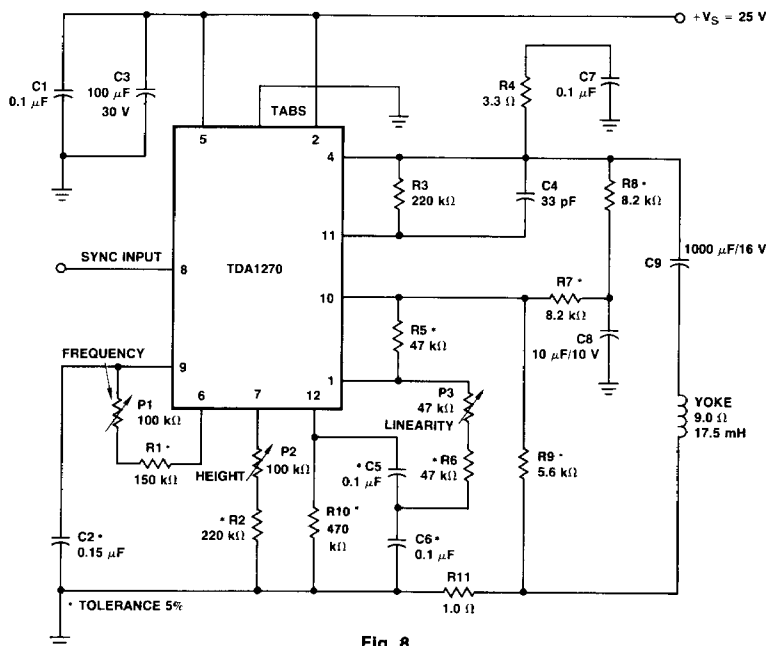

Fig. 8

Typical Performance of Circuit in Fig. 8

$I_+$	Supply Current	110	mA
$t_{fly}$	Flyback Time	0.8	ms
$I_y$	Maximum Scanning Current (Peak to Peak)	0.9	A
$V_+$	Operating Supply Voltage	23 to 27	V
$P_T$	TDA1270 Power Dissipation	2.4	W

For safe working up to  $T_A = 50^\circ\text{C}$  a heatsink of  $\theta = 30^\circ\text{C/W}$  is required and each tab of the TDA1270 must be soldered to 1 cm<sup>2</sup> copper area of the printed circuit board.

PC BOARD AND COMPONENT LAYOUT FOR THE CIRCUIT OF FIG. 8 (1:1 SCALE)

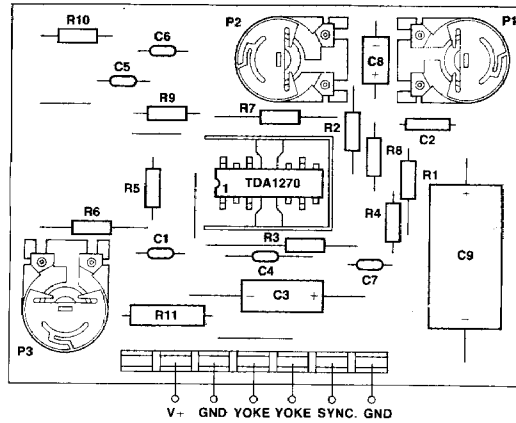

Fig. 9

Fig. 10 shows an output stage employing two NPN power transistors and a service switch that stops the vertical deflection during convergence adjustment.

VERTICAL DEFLECTION CIRCUIT EMPLOYING TWO NPN POWER OUTPUT TRANSISTORS.

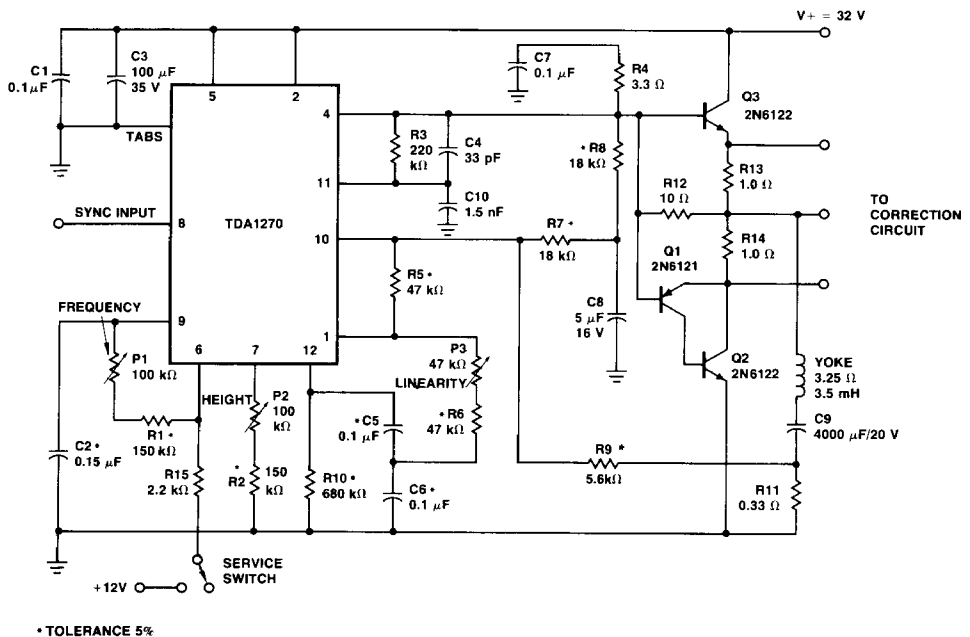

Fig. 10

**MOUNTING INSTRUCTIONS**

The junction to ambient thermal resistance of the TDA1170 and TDA1270 can be reduced by soldering the tabs to a suitable copper area of the printed circuit board (Fig. 12) or to an external heatsink (Fig. 13).

The diagram of Fig. 14 shows the maximum dissippable power  $P_D$  and the  $\theta_{J-A}$  as a function of the side "L" to two equal square copper areas having a thickness of  $35 \mu$  (1.4 mil). During soldering, the tab temperature must not exceed  $250^\circ\text{C}$  and the soldering time must not be longer than 10 seconds.

The external heatsink or printed circuit copper area must be connected to electrical ground.

**EXAMPLE OF P.C. BOARD COPPER AREA USED AS HEATSINK**

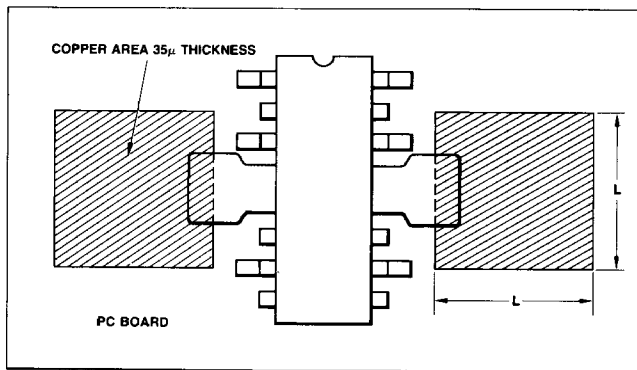

Fig. 12

**EXAMPLE OF CIRCUIT WITH ETHERNAL HEATSINK**

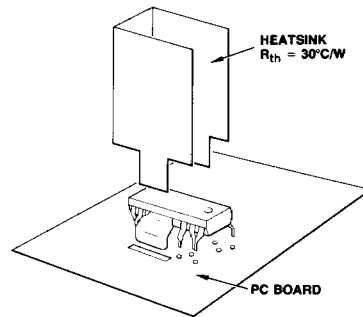

Fig. 13

**MAXIMUM POWER DISSIPATION AND THERMAL RESISTANCE AS A FUNCTION OF COPPER LENGTH (L)**

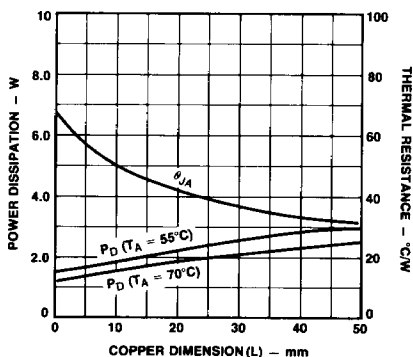

Fig. 14

**MAXIMUM POWER DISSIPATION AS A FUNCTION OF AMBIENT TEMPERATURE**

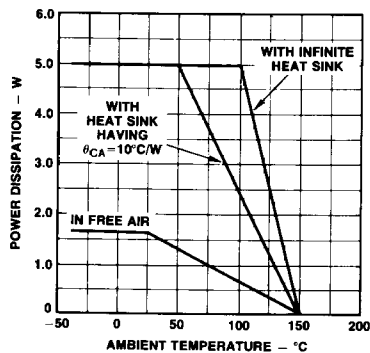

Fig. 15