

32-kHz Watch CMOS IC with Motor Regulation (3.0 V)

Features

- 32-kHz oscillator
- 2.2 V to 3.6 V operating voltage range
- 120 nA typical current consumption
- Motor regulation for minimum current consumption (MCAP)
- Voltage regulator
- Amplitude controlled oscillator
- Integrated capacitors, mask-selectable
- Mask options for pad designation and adaptation to the motor
- Low resistance outputs for bipolar stepping motor
- Motor fast-test function

Pad Configuration

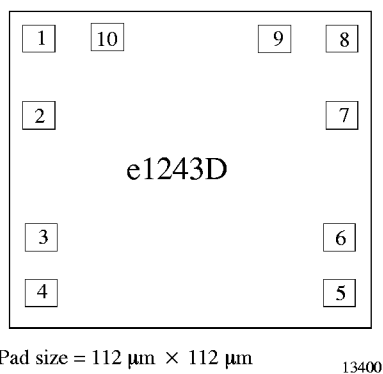

Figure 1.

Chip size: 1.75 x 1.18 mm²

General Description

The e1243D is an integrated circuit in CMOS Silicon-Gate Technology for analog watches. It consists of a 32-kHz oscillator, frequency dividers down to 1/2 Hz, output pulse formers and push-pull motor drivers. Capacitors are provided (selectable mask option) for tuning the crystal. Low current consumption and high oscillator stability are achieved by an on-chip voltage regulator.

Pin	Symbol	Function
1 to 6, 8	V _{SS}	Negative supply voltage
1 to 5, 8	V _{DD}	Positive supply voltage
1 to 4	OSCIN/ OSCOUT	Oscillator input/ output
7 5 and 6	MOT 1 MOT 2	Motor drive outputs
1 to 5, 8	RESET	Reset input
1 to 5, 8	M_TEST	Motor test input

Absolute Maximum Ratings

Parameters	Symbol	Value	Unit
Supply voltage	V _{DD}	-0.3 to +5 V	V
Input voltage range, all inputs	V _{IN}	(V _{SS} - 0.3 V) ≤ V _{IN} , ≤ (V _{DD} + 0.3 V)	V
Output short-circuit duration		indefinite	
Power dissipation (DIL package)	P _{tot}	125 mW	mW
Operating ambient temperature range	T _{amb}	-20 to +70	°C
Storage temperature range	T _{stg}	-40 to +125	°C
Lead temperature during soldering at 2 mm distance, 10 seconds	T _{sld}	260	°C

Absolute maximum ratings define parameter limits which, if exceeded, may permanently change or damage the device.

All inputs and outputs in TEMIC Semiconductors circuits are protected against electrostatic discharges. However,

precautions to minimize the build-up of electrostatic charges during handling are recommended.

This circuit is protected against supply voltage reversal for typically 5 minutes.

Functional Description

Voltage Regulator

An integrated voltage regulator provides the oscillator and the leading five divider stages with a well controlled positive supply voltage V_{REG} . Due to this reduced supply voltage, the frequency stability of the oscillator versus supply voltage variations is significantly improved and the current consumption of the circuit is minimized.

Oscillator

For generation of the 32768-Hz clock frequency, an amplitude controlled oscillator is used. The amplitude of the oscillator input signal is held constant independent of external load conditions (i.e., trimmer capacitance and quartz characteristics), minimizing the current consumption of the oscillator. For typical supply current versus C_{TRIM} and quartz R_S variations see figure 3.

A total capacitance of 22 pF is integrated, which can be selected for C_{OSCOUT} in 1 pF increments by metal mask options.

A trimming capacitor (chip capacitor) for frequency adjustment has to be connected between OSCIN and V_{SS} .

Important: It is recommended to connect the quartz case to V_{SS} .

Motor Drive Output

The e1243D contains two push-pull output buffers for driving bipolar stepper motors. During a motor pulse, the n-channel device of one buffer and the p-channel device of the other buffer is activated. Between two pulses, the p-channel devices of both buffers are active (see figure 4). Motor period t_M is 2 s.

Reset

Connecting the RESET input to V_{DD} for at least 31.2 ms resets the frequency divider, thus disabling further motor pulses. Motor pulses in progress when the reset function is applied will be completed. After releasing the RESET pad from V_{DD} , the next motor pulse appears with a delay of one half motor period (1 s) on the drive output opposed to the former (see figure 5).

4.2.7 Motor Test

Connecting M_TEST to V_{DD} for at least 31.2 ms changes the motor period from 2 s to either 62.5 ms or 125 ms (t_{MT} mask options), while the timing of the motor current regulation remains unchanged (see figure 4).

MCAP Motor Regulation.

(MCAP = Minimum Current Adaptive Pulse)

In order to reduce the motor current consumption to its absolute minimum for a given mechanical load (i.e., required torque), the motor drive parameters are adapted during **each** motor pulse to the existing load condition.

Adaption to a given motor is done by appropriate selection of the parameters t_1 , f_{chop} , t_2 , t_{ref} , t_{inc} , t_{dec} , t_{crit} , t_{max} , t_3 and i_{ref} .

Regulation Algorithm

The regulation is performed in the following way (please refer to figure 6 and 7):

At the end of t_1 , the motor current I_{MOT} is measured and this measured value is stored.

After measurement of the motor current, a reference current i_{ref} is generated, which is typically 100% of the previously (at the end of t_1) measured motor current and the actual motor current is compared every 61 μ s with i_{ref} .

If the motor current is found to be below i_{ref} , then a drive pulse t_2 is generated (see figure 6). At the end of the first t_2 pulse, the motor current is again compared to i_{ref} and as soon as the motor current falls again below i_{ref} , a new drive pulse t_2 is generated (see figure 6).

This is continued as long as the motor current drops below i_{ref} within a time shorter than t_{ref} – after the preceding drive pulse t_2 , or until the time t_{crit} has elapsed.

If the motor current does not drop below i_{ref} during the time t_{ref} , then no further motor pulses t_2 are generated (see figure 6).

In addition to the above, the following takes place in order to achieve reliable function over a wide range of mechanical load and power supply voltage (and minimum current consumption for a given load condition).

At power-up or with RESET = V_{DD} , t_{on} is set to its maximum value (duty cycle 50% or 100%).

If the motor pulses t_2 are terminated before t_{dec} has elapsed, then t_{on} is decremented, for the following motorpulse.

t_{on} may be decremented repetitively (after each motor pulse), until the t_2 pulses are terminated after t_{dec} or until a minimum width of t_{on} is reached.

If the motor pulses t_2 are terminated after t_{dec} but before t_{inc} has elapsed (which means that the duty cycle of the chopped pulses – t_{on}/t_{off} – during t_1 is well adapted to the mechanical load), then t_{on} remains unchanged.

If the motor pulses t_2 are not terminated at the end of t_{inc} , then t_{on} is incremented, for the following motorpulse.

t_{on} may be incremented repetitively (after each motor pulse) until the t_2 pulses are terminated before t_{inc} – or until a maximum width for t_{on} of 50% or 100% duty cycle is reached.

If the motor pulses t_2 are not terminated at t_{crit} , then an additional motorpulse t_3 (duty cycle 50% or 100%) will be generated (see figure 7).

In this case, the following motorpulse t_1 starts again with its maximum duty cycle (i.e., same condition as after power-up or RESET = V_{DD}).

Operating Characteristics

$V_{SS} = 0$, $V_{DD} = 3.0$ V, $T_{amb} = +25^\circ\text{C}$; unless otherwise specified. All voltage levels are measured with reference to V_{SS} . Test crystal as specified below.

Parameters	Test Conditions / Pins	Symbol	Min.	Typ.	Max.	Unit
Operating voltage	Functional test (figure 2)	V_{DD}	2.2		3.6	V
Operating current	$C_{OUT} = 16$ pF, $C_{TR} = 15$ pF $R_L = \infty$	I_{DD}		120	300	nA
RESET input current	RESET = V_{DD}	I_R		8		nA
Motor outputs						
Motor output current	$R_L = 2$ k Ω , $V_{DD} = 3.0$ V	I_M	± 1.35			mA
Motor period		t_M	2			s
Motor pulse width		t_{pw}	Mask option			ms
Oscillator						
Stability vs. supply voltage	$\Delta V_{SS} = 100$ mV, $C_{TR} = 5$ pF	$\Delta f/f$		0.1		ppm
Start-up voltage	within 2 sec	V_{ST}	2.4			V
Integrated input capacitance		C_{OSCIN}		2		pF
Integrated output capacitance		C_{OSCOUT}	Mask option		22	pF

Note 1: Typical parameters represent the statistical mean values

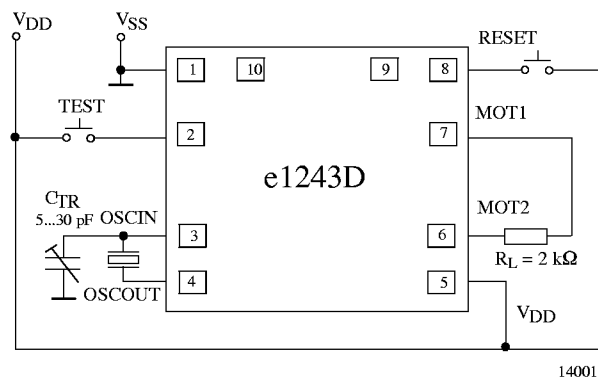

Figure 2. Functional test

Test Crystal Specification

Frequency	$f = 32768$ Hz
Series resistance	$R_S = 30$ k Ω
Static capacitance	$C_O = 1.0$ pF
Dynamic capacitance	$C_1 = 2.5$ fF
Load capacitance	$C_L = 8$ pF

Note: Maximum series resistance $R_S = 50$ k Ω

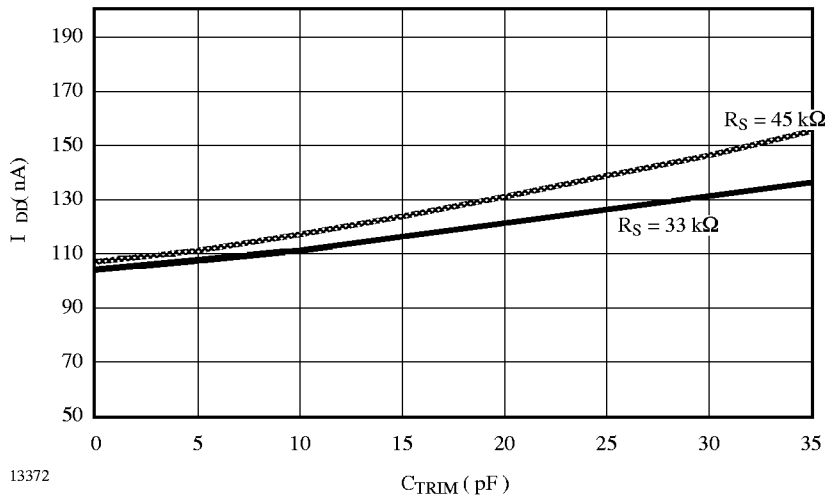

Figure 3. $I_{DD} = f(C_{TRIM}, \text{quartz})$

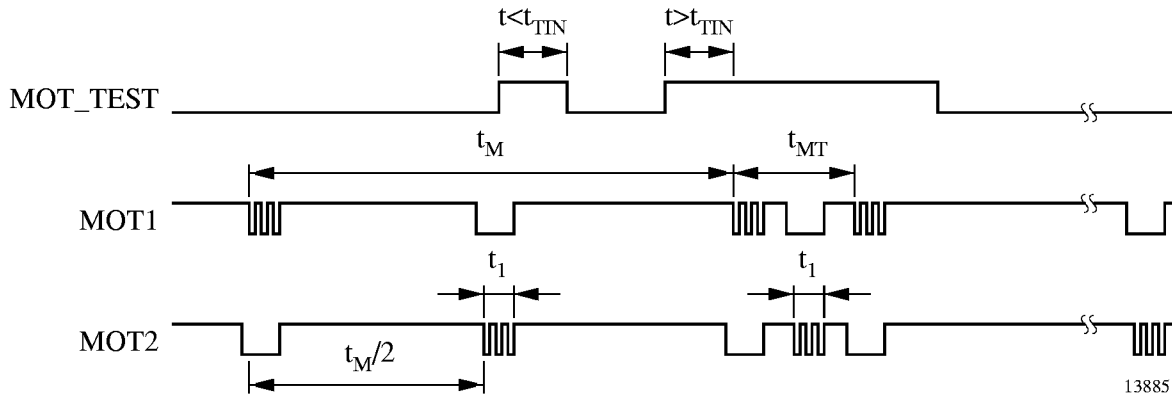

Figure 4. Motor drive outputs in normal mode and motortest

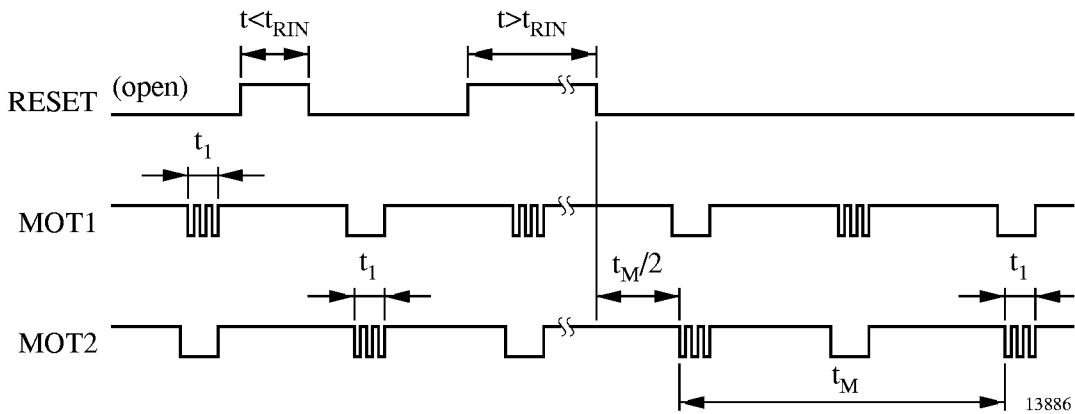

Figure 5. Motor drive outputs and reset

Note: For sake of simplicity, only the t_1 -portion of the motorpulse t_{PW} is shown in figure 4 and figure 5. The complete shape of the motorpulse is shown in figure 6 and figure 7.

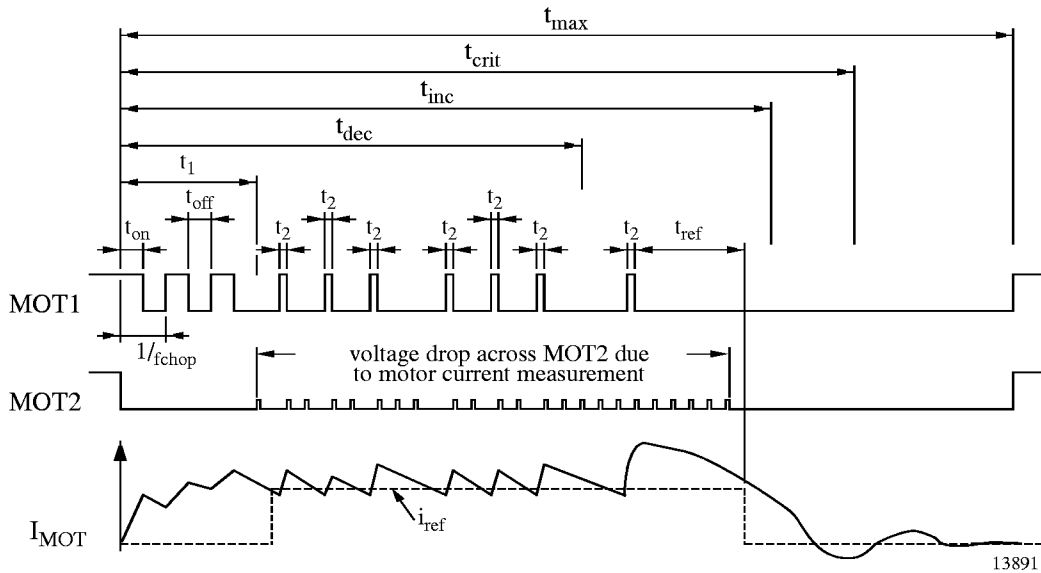

Figure 6. Motor pulse shape

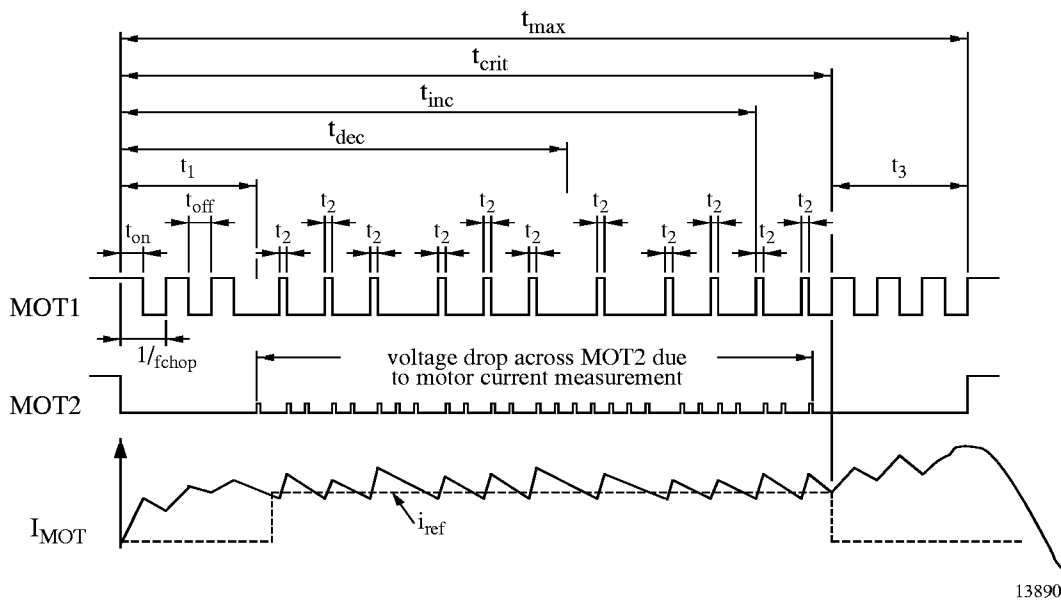

Figure 7. Motor pulse shape (no rotation at t_{crit})

We reserve the right to make changes to improve technical design and may do so without further notice.

Parameters can vary in different applications. All operating parameters must be validated for each customer application by the customer. Should the buyer use TEMIC Semiconductors products for any unintended or unauthorized application, the buyer shall indemnify TEMIC Semiconductors against all claims, costs, damages, and expenses, arising out of, directly or indirectly, any claim of personal damage, injury or death associated with such unintended or unauthorized use.

TEMIC Semiconductor GmbH, P.O.B. 3535, D-74025 Heilbronn, Germany
Telephone: 49 (0)7131 67 2594, Fax number: 49 (0)7131 67 2423