

GaN UV Photodiode
SD012-UVA-011

Precision – Control – Results

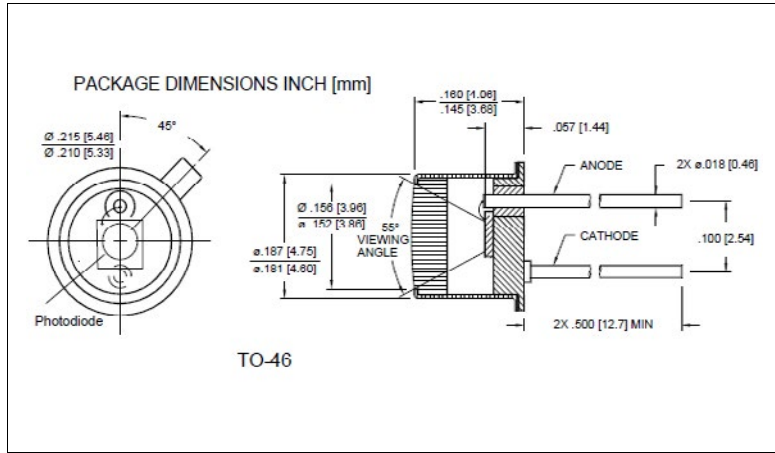
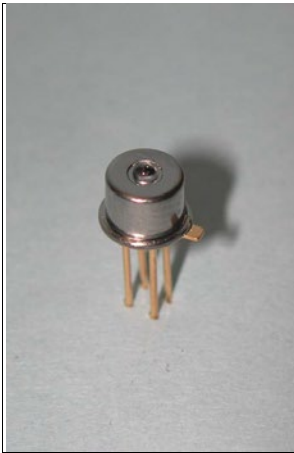

DESCRIPTION

The SD012-UVA-005 is a GaN UV photodiode with a 0.076 mm² active area. Unlike most UV detectors it cuts off unwanted visible light from its detection spectrum (220-370nm), thereby eliminating the need for optical filter. Photodiode is assembled packaged in a hermetic TO-46 package

RELIABILITY

This Luna high-reliability device is in principle able to meet military test requirements (Mil-STD-750, Mil-STD-883) after proper screening and group test. Contact Luna for recommendations on specific test conditions and procedures.

FEATURES

- Schottky-Type Photodiode
- Photovoltaic Mode Operation
- Low Noise
- High Speed
- Visible Blindness

APPLICATIONS

- UV Detection and Monitoring
- Medical
- Military

ABSOLUTE MAXIMUM RATINGS

SYMBOL	MIN	MAX	UNITS	T _a = 23°C UNLESS NOTED OTHERWISE	
Storage Temperature	-40	to +125	°C	-	-
Operating Temperature	-30	to +85	°C	-	-
Soldering Temperature	-	-	+260	°C	-
Forward Current	-	-	1.0	mA	-
Reverse Voltage	-	-	5.0	V	-

Information in this technical datasheet is believed to be correct and reliable. However, no responsibility is assumed for possible inaccuracies or omission. Specifications are subject to change without notice.

REV 01-04-16
© 2016 Luna Optoelectronics. All rights reserved.

**GaN UV Photodiode
SD012-UVA-011**

Precision – Control – Results

OPTO-ELECTRICAL PARAMETERS

T_a = 23°C UNLESS NOTED OTHERWISE

PARAMETER	TEST CONDITIONS	MIN	TYP	MAX	UNITS
Dark Current	V _R = 0.1V	-	0.1	100	pA
Shunt Resistance	V _R = 10 mV	1.0	100	-	GΩ
Short Circuit Current	UVI=1.0	-	20	-	nA
Spectral Application Range	Spot Scan	220	-	370	nm
Responsivity Peak	λ = 350 nm V, V _R = 0 V	-	0.18	-	A/W
Capacitance	V _{bias} = 0V; f = 1 MHz	-	10	-	pF
Noise Equivalent Power	λ=350	-	1.6	-	10 ⁻¹⁷ W/Hz ^{0.5}

TYPICAL PERFORMANCE

UV-A PHOTOCURRENT

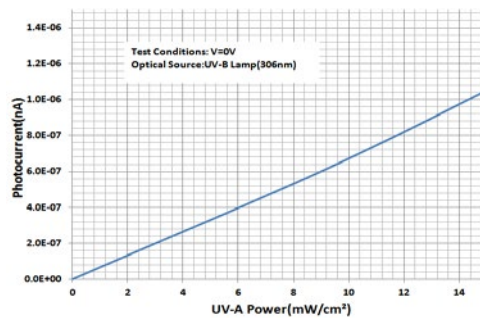

NOISE vs. BIAS

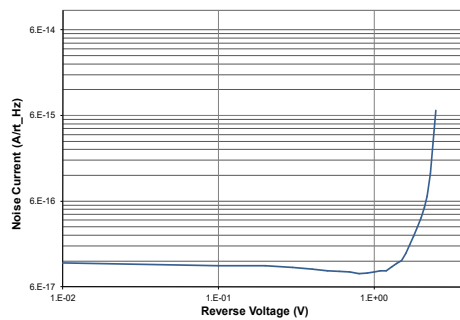

UV-I PHOTOCURRENT

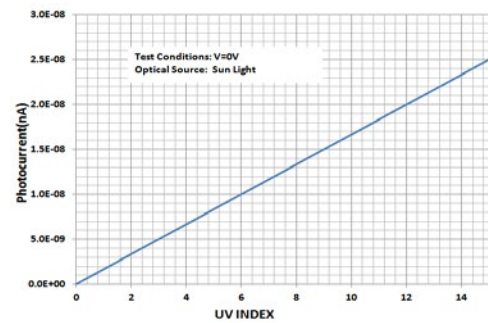

SPECTRAL RESPONSE

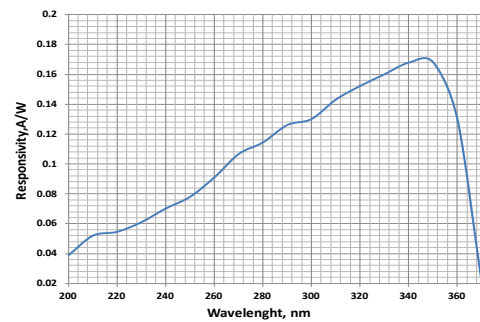

Information in this technical datasheet is believed to be correct and reliable. However, no responsibility is assumed for possible inaccuracies or omission. Specifications are subject to change without notice.

REV 01-04-16

© 2016 Luna Optoelectronics. All rights reserved.