

33C408

4 Megabit (512K x 8-Bit) CMOS SRAM

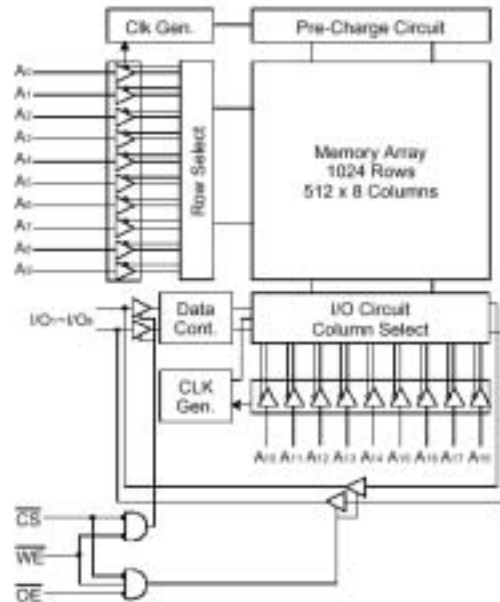
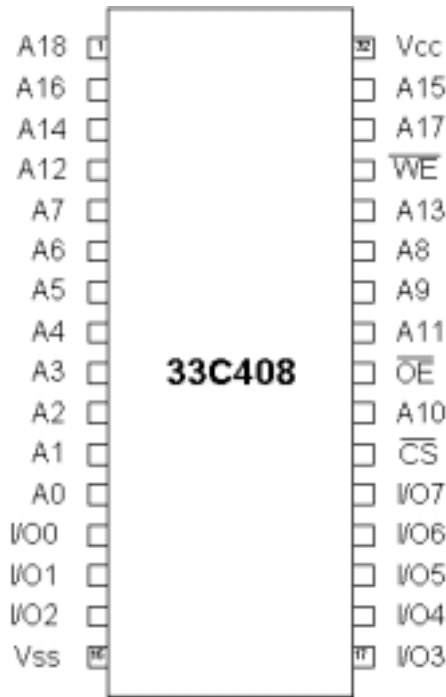

Logic Diagram

FEATURES:

- RAD-PAK® Technology radiation-hardened against natural space radiation
- 524,288 x 8 bit organization
- Total dose hardness:
 - > 100 krad (Si), depending upon space mission
- Excellent Single Event Effect
 - $SEL_{TH} > 68 \text{ MeV/mg/cm}^2$
 - $SEU_{TH} = 3 \text{ MeV/mg/cm}^2$
 - SEU saturated cross section: $6E-9 \text{ cm}^2/\text{bit}$
- Package:
 - 32-Pin RAD-PAK® flat pack
 - 32-Pin Non-RAD-PAK® flat pack
- Fast access time:
 - 20, 25, 30 ns maximum times available
- Single $5V \pm 10\%$ power supply
- Fully static operation
 - No clock or refresh required
- Three state outputs
- TTL compatible inputs and outputs
- Low power:
 - Standby: 60 mA (TTL); 10 mA (CMOS)
 - Operation: 180 mA (20 ns); 170 mA (25 ns); 160 mA (30 ns)

DESCRIPTION:

The 33C408 high-density 4 Megabit SRAM microcircuit features a greater than 100 krad (Si) total dose tolerance, depending upon space mission. Using DDC's radiation-hardened RAD-PAK® packaging technology, the 33C408 realizes a high density, high performance, and low power consumption. Its fully static design eliminates the need for external clocks, while the CMOS circuitry reduces power consumption and provides higher reliability. The 33C408 is equipped with eight common input/output lines, chip select and output enable, allowing for greater system flexibility and eliminating bus contention. The 33C408 features the same advanced 512K x 8-bit SRAM, high-speed, and low-power demand as the commercial counterpart.

DDC's patented RAD-PAK packaging technology incorporates radiation shielding in the microcircuit package. It eliminates the need for box shielding while providing the required radiation shielding for a lifetime in orbit or space mission. In a GEO orbit, RAD-PAK provides greater than 100 krad (Si) radiation dose tolerance. This product is available with screening up to Class S.

TABLE 1. PINOUT DESCRIPTION

| PIN | SYMBOL | DESCRIPTION |
|---|------------------------|---------------------|
| 12-5, 27, 26, 23, 25, 4, 28, 3, 31, 2, 30, 1 | A0-A18 | Address Inputs |
| 29 | $\overline{\text{WE}}$ | Write Enable |
| 22 | $\overline{\text{CS}}$ | Chip Select |
| 24 | $\overline{\text{OE}}$ | Output Enable |
| 13-15, 17-21 | I/O 1-I/O 8 | Data Inputs/Outputs |
| 32 | V_{CC} | Power (+5.0V) |
| 16 | V_{SS} | Ground |

TABLE 2. 33C408 ABSOLUTE MAXIMUM RATINGS

| PARAMETER | SYMBOL | MIN | MAX | UNIT |
|---|---------------------------------|------|-----------------------|--------------------|
| Voltage on V_{CC} supply relative to V_{SS} | V_{CC} | -0.5 | 7.0 | V |
| Voltage on any pin relative to V_{SS} | $V_{\text{IN}}, V_{\text{OUT}}$ | -0.5 | $V_{\text{CC}} + 0.5$ | V |
| Power Dissipation | P_{D} | -- | 1.0 | W |
| Storage Temperature | T_{S} | -65 | +150 | $^{\circ}\text{C}$ |
| Operating Temperature | T_{A} | -55 | +125 | $^{\circ}\text{C}$ |

TABLE 3. DELTA LIMITS

| PARAMETER | VARIATION |
|------------------|---------------------------------------|
| I_{CC1} | $\pm 10\%$ of stated vaule in Table 6 |
| I_{SB} | $\pm 10\%$ of stated vaule in Table 6 |
| I_{SB1} | $\pm 10\%$ of stated vaule in Table 6 |
| I_{LI} | $\pm 10\%$ of stated vaule in Table 6 |

TABLE 4. 33C408 RECOMMENDED OPERATING CONDITIONS
($V_{CC} = 5.0 \pm 10\%$, $T_A = -55$ TO $+125$ °C, UNLESS OTHERWISE NOTED)

| PARAMETER | SYMBOL | MIN | MAX | UNIT |
|---------------------------------|---------------|------|--------------|------|
| Supply Voltage | V_{CC} | 4.5 | 5.5 | V |
| Ground | V_{SS} | 0 | 0 | V |
| Input High Voltage ¹ | V_{IH} | 2.2 | $V_{CC}+0.5$ | V |
| Input Low Voltage ² | V_{IL} | -0.5 | 0.8 | V |
| Thermal Impedance | Θ_{JC} | -- | 1.21 | °C/W |

- V_{IH} (max) = $V_{CC} + 2.0V$ ac (pulse width ≤ 10 ns) for $I \leq 20$ mA
- V_{IL} (min) = $-2.0V$ ac (pulse width ≤ 10 ns) for $I \leq 20$ mA

TABLE 5. 33C408 DC ELECTRICAL CHARACTERISTICS
($V_{CC} = 5V \pm 10\%$, $T_A = -55$ TO $+125$ °C, UNLESS OTHERWISE SPECIFIED)

| PARAMETER | SYMBOL | CONDITION | SUBGROUPS | MIN | MAX | UNIT |
|--|-----------|--|-----------|-----|-------------------|---------|
| Input Leakage Current | I_{LI} | $V_{IN} = V_{SS}$ to V_{CC} | 1, 2, 3 | -2 | 2 | μA |
| Output Leakage Current | I_{LO} | $\overline{CS} = V_{IH}$ or $\overline{OE} = V_{IH}$ or $\overline{WE} = V_{IL}$, $V_{OUT} = V_{SS}$ to V_{CC} | 1, 2, 3 | -2 | 2 | μA |
| Output Low Voltage | V_{OL} | $I_{OL} = 8mA$ | 1, 2, 3 | -- | 0.4 | V |
| Output High Voltage | V_{OH} | $I_{OH} = -4mA$ | 1, 2, 3 | 2.4 | -- | V |
| Operating Current -20 -25 -30 | I_{CC} | Min cycle, 100% Duty, $\overline{CS} = V_{IL}$, $I_{OUT} = 0mA$, $V_{IN} = V_{IH}$ or V_{IL} | 1, 2, 3 | -- | 180 170 160 | mA |
| Standby Power Supply Current | I_{SB} | $\overline{CS} = V_{IH}$, Min Cycle | 1, 2, 3 | -- | 60 | mA |
| CMOS Standby Power Supply Current | I_{SB1} | $\overline{CS} \geq V_{CC} - 0.2V$, $f = 0$ MHz, $V_{IN} \geq V_{CC} - 0.2V$ or $V_{IN} < 0.2V$ | 1, 2, 3 | -- | 10 | mA |
| Input Capacitance ¹ | C_{IN} | $V_{IN} = 0V$, $f = 1MHz$, $T_A = 25$ °C | 1, 2, 3 | -- | 7 | pF |
| Output Capacitance ¹ | C_{IO} | $V_{IO} = 0V$ | 4, 5, 6 | -- | 8 | pF |

- Guaranteed by design.

TABLE 6. 33C408 AC TEST CONDITIONS AND CHARACTERISTICS
($V_{CC} = 5.0 \pm 10\%$, $T_A = -55$ TO $+125$ °C, UNLESS OTHERWISE NOTED)

| PARAMETER | MIN | TYP | MAX | UNITS |
|---|-----|-----|-----|-------|
| Input Pulse Level | 0.0 | -- | 3.0 | V |
| Output Timing Measurement Reference Level | -- | -- | 1.5 | V |

TABLE 6. 33C408 AC TEST CONDITIONS AND CHARACTERISTICS

($V_{CC} = 5.0 \pm 10\%$, $T_A = -55$ TO $+125$ °C, UNLESS OTHERWISE NOTED)

| PARAMETER | MIN | TYP | MAX | UNITS |
|--|-----|-----|-----|-------|
| Input Rise/Fall Time | -- | -- | 3.0 | ns |
| Input Timing Measurement Reference Level | -- | -- | 1.5 | V |

TABLE 7. 33C408 AC CHARACTERISTICS FOR READ CYCLE

($V_{CC} = 5V \pm 10\%$, $T_A = -55$ TO $+125$ °C, UNLESS OTHERWISE SPECIFIED)

| PARAMETER | SYMBOL | SUBGROUPS | MIN | TYP | MAX | UNIT |
|------------------------------------|-----------|-----------|-----|-----|-----|------|
| Read Cycle Time | t_{RC} | 9, 10, 11 | | | | ns |
| -20 | | | 20 | -- | -- | |
| -25 | | | 25 | -- | -- | |
| -30 | | | 30 | -- | -- | |
| Address Access Time | t_{AA} | 9, 10, 11 | | | | ns |
| -20 | | | -- | -- | 20 | |
| -25 | | | -- | -- | 25 | |
| -30 | | | -- | -- | 30 | |
| Chip Select Access Time | t_{CO} | 9, 10, 11 | | | | ns |
| -20 | | | -- | -- | 20 | |
| -25 | | | -- | -- | 25 | |
| -30 | | | -- | -- | 30 | |
| Output Enable to Output Valid | t_{OE} | 9, 10, 11 | | | | ns |
| -20 | | | -- | -- | 10 | |
| -25 | | | -- | -- | 12 | |
| -30 | | | -- | -- | 14 | |
| Chip Enable to Output in Low-Z | t_{LZ} | 9, 10, 11 | | | | ns |
| -20 | | | -- | 3 | -- | |
| -25 | | | -- | 3 | -- | |
| -30 | | | -- | 3 | -- | |
| Output Enable to Output in Low-Z | t_{OLZ} | 9, 10, 11 | | | | ns |
| -20 | | | -- | 0 | -- | |
| -25 | | | -- | 0 | -- | |
| -30 | | | -- | 0 | -- | |
| Chip Deselect to Output in High-Z | t_{HZ} | 9, 10, 11 | | | | ns |
| -20 | | | -- | 5 | -- | |
| -25 | | | -- | 6 | -- | |
| -30 | | | -- | 8 | -- | |
| Output Disable to Output in High-Z | t_{OHZ} | 9, 10, 11 | | | | ns |
| -20 | | | -- | 5 | -- | |
| -25 | | | -- | 6 | -- | |
| -30 | | | -- | 8 | -- | |
| Output Hold from Address Change | t_{OH} | 9, 10, 11 | | | | ns |
| -20 | | | 3 | -- | -- | |
| -25 | | | 5 | -- | -- | |
| -30 | | | 6 | -- | -- | |

TABLE 7. 33C408 AC CHARACTERISTICS FOR READ CYCLE

($V_{CC} = 5V \pm 10\%$, $T_A = -55$ TO $+125$ °C, UNLESS OTHERWISE SPECIFIED)

| PARAMETER | SYMBOL | SUBGROUPS | MIN | TYP | MAX | UNIT |
|--------------------------------|----------|-----------|-----|-----|-----|------|
| Chip Select to Power Up Time | t_{PU} | 9, 10, 11 | -- | 0 | -- | ns |
| -20 | | | -- | 0 | -- | |
| -25 | | | -- | 0 | -- | |
| -30 | | | -- | 0 | -- | |
| Chip Select to Power Down Time | t_{PD} | 9, 10, 11 | -- | 10 | -- | ns |
| -20 | | | -- | 15 | -- | |
| -25 | | | -- | 20 | -- | |
| -30 | | | -- | 20 | -- | |

TABLE 8. 33C408 FUNCTIONAL DESCRIPTION

| \overline{CS} | \overline{WE} | \overline{OE} | MODE | I/O PIN | SUPPLY CURRENT |
|-----------------|-----------------|-----------------|----------------|-----------|----------------------|
| H | X ¹ | X ¹ | Not Select | High-Z | I_{SB} , I_{SB1} |
| L | H | H | Output Disable | High-Z | I_{CC} |
| L | H | L | Read | D_{OUT} | I_{CC} |
| L | L | X ¹ | Write | D_{IN} | I_{CC} |

1. X = don't care.

Subgroups

TABLE 9. 33C408 AC CHARACTERISTICS FOR WRITE CYCLE

($V_{CC} = 5V \pm 10\%$, $T_A = -55$ TO $+125$ °C, UNLESS OTHERWISE SPECIFIED)

| PARAMETER | SUBGROUPS | SYMBOL | MIN | TYP | MAX | UNIT |
|-------------------------------|-----------|----------|-----|-----|-----|------|
| Write Cycle Time | 9, 10, 11 | t_{WC} | 20 | -- | -- | ns |
| -20 | | | 25 | -- | -- | |
| -25 | | | 30 | -- | -- | |
| -30 | | | 30 | -- | -- | |
| Chip Select to End of Write | 9, 10, 11 | t_{CW} | 14 | -- | -- | ns |
| -20 | | | 15 | -- | -- | |
| -25 | | | 17 | -- | -- | |
| -30 | | | 17 | -- | -- | |
| Address Setup Time | 9, 10, 11 | t_{AS} | 0 | -- | -- | ns |
| -20 | | | 0 | -- | -- | |
| -25 | | | 0 | -- | -- | |
| -30 | | | 0 | -- | -- | |
| Address Valid to End of Write | 9, 10, 11 | t_{AW} | 14 | -- | -- | ns |
| -20 | | | 15 | -- | -- | |
| -25 | | | 17 | -- | -- | |
| -30 | | | 17 | -- | -- | |

TABLE 9. 33C408 AC CHARACTERISTICS FOR WRITE CYCLE
 ($V_{CC} = 5V \pm 10\%$, $T_A = -55$ TO $+125$ °C, UNLESS OTHERWISE SPECIFIED)

| PARAMETER | SUBGROUPS | SYMBOL | MIN | TYP | MAX | UNIT |
|---|-----------|-----------|-----|-----|-----|------|
| Write Pulse Width (\overline{OE} High) | 9, 10, 11 | t_{WP} | | | | ns |
| -20 | | | 14 | -- | -- | |
| -25 | | | 15 | -- | -- | |
| -30 | | | 17 | -- | -- | |
| Write Recovery Time | 9, 10, 11 | t_{WR} | | | | ns |
| -20 | | | 0 | -- | -- | |
| -25 | | | 0 | -- | -- | |
| -30 | | | 0 | -- | -- | |
| Write to Output in High-Z | 9, 10, 11 | t_{WHZ} | | | | ns |
| -20 | | | -- | 5 | -- | |
| -25 | | | -- | 5 | -- | |
| -30 | | | -- | 6 | -- | |
| Write Pulse Width (\overline{OE} Low) | 9, 10, 11 | t_{WP1} | | | | ns |
| -20 | | | -- | 20 | -- | |
| -25 | | | -- | 25 | -- | |
| -30 | | | -- | 30 | -- | |
| Data to Write Time Overlap | 9, 10, 11 | t_{DW} | | | | ns |
| -20 | | | 9 | -- | -- | |
| -25 | | | 10 | -- | -- | |
| -30 | | | 11 | -- | -- | |
| End Write to Output Low-Z | 9, 10, 11 | t_{OW} | | | | ns |
| -20 | | | -- | 6 | -- | |
| -25 | | | -- | 7 | -- | |
| -30 | | | -- | 8 | -- | |
| Data Hold from Write Time | 9, 10, 11 | t_{DH} | | | | ns |
| -20 | | | 0 | -- | -- | |
| -25 | | | 0 | -- | -- | |
| -30 | | | 0 | -- | -- | |

FIGURE 1. AC TEST LOADTIMING WAVEFORM OF READ CYCLE(1)

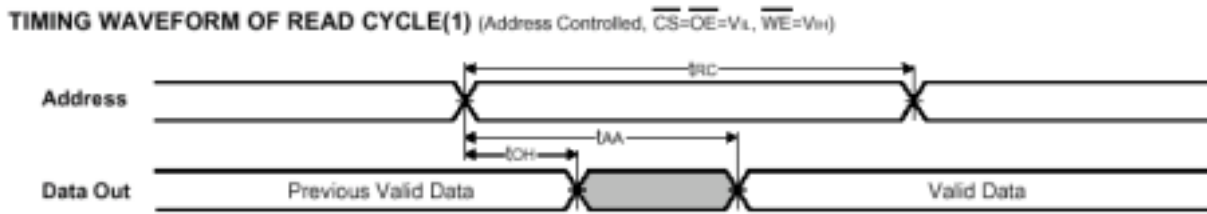
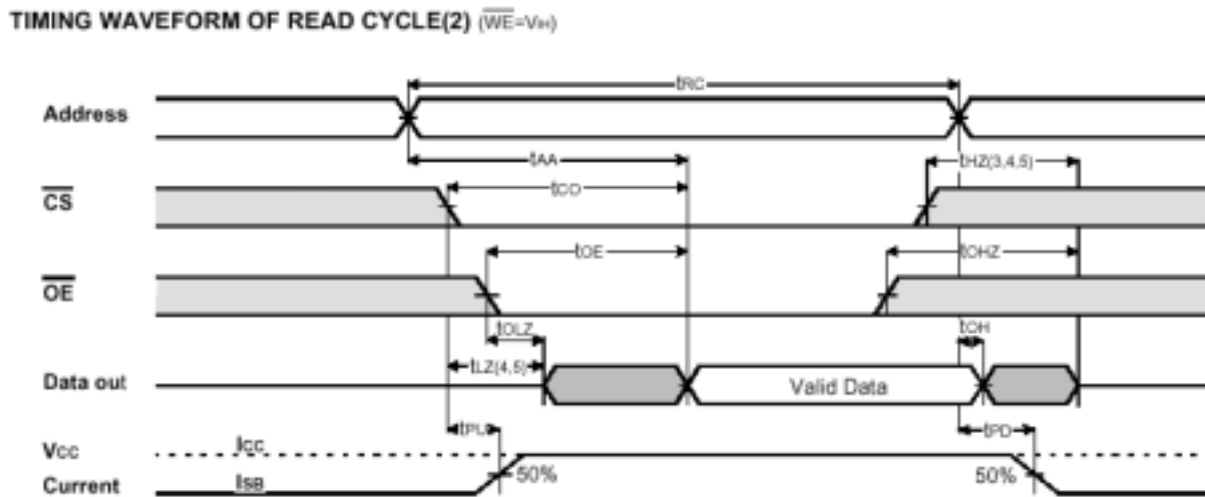

FIGURE 2. TIMING WAVEFORM OF READ CYCLE (2)



Read Cycle Notes:

1. \overline{WE} is high for read cycle.
2. All read cycle timing is referenced from the last valid address to the first transition address.
3. t_{HZ} and t_{OHZ} are defined as the time at which the outputs achieve the open circuit condition and are not referenced to V_{OH} or V_{OL} levels.
4. At any given temperature and voltage condition, $t_{HZ(max)}$ is less than $t_{LZ(min)}$ both for a given device and from device to device.
5. Transition is measured + 200mV from steady state voltage. This parameter is sampled and not 100% tested.
6. Device is continuously selected with $\overline{CS} = V_{IL}$.
7. Address valid prior to coincident with \overline{CS} transition low.
8. For common I/O applications, minimization or elimination of bus contention condition is necessary during read and write cycle.

FIGURE 3. TIMING WAVEFORM OF WRITE CYCLE(1)

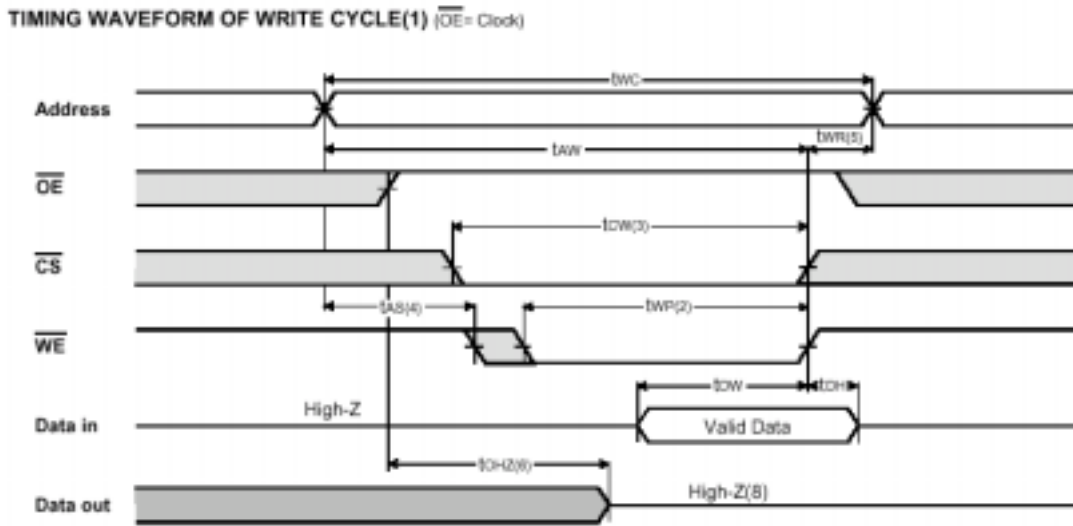

FIGURE 4. TIMING WAVEFORM OF WRITE CYCLE(2)

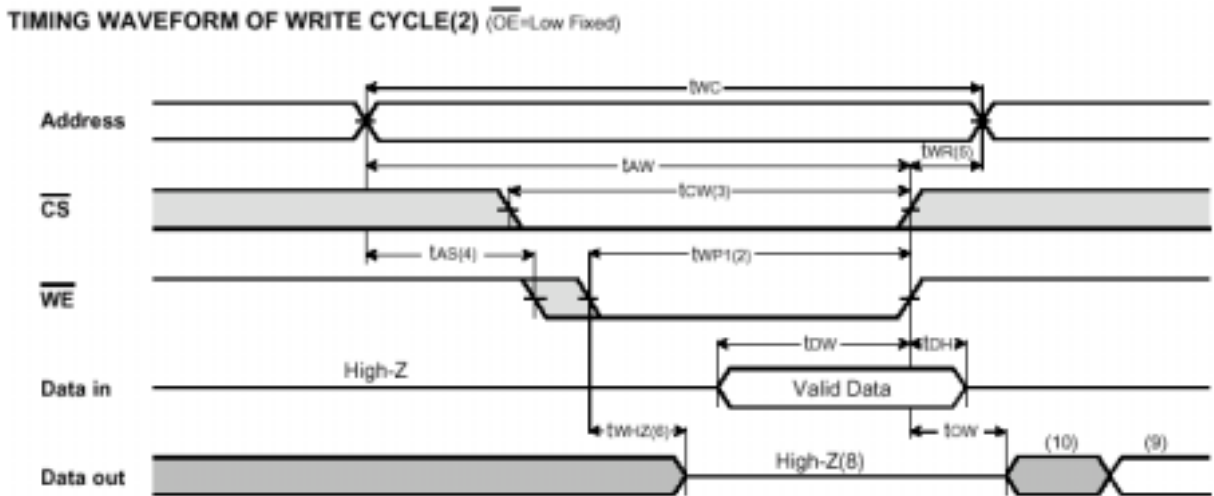
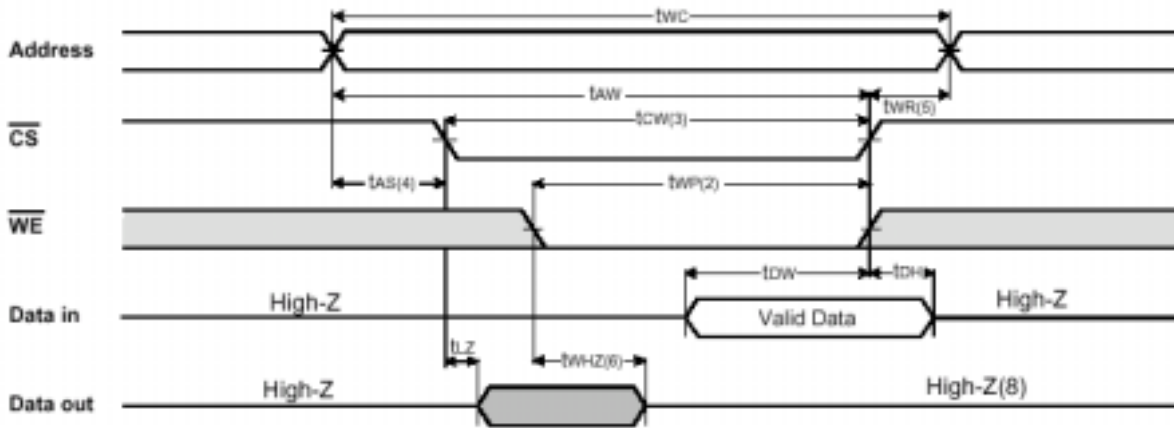

FIGURE 5. TIMING WAVEFORM OF WRITE CYCLE (3)

TIMING WAVEFORM OF WRITE CYCLE(3) (\overline{CS} = Controlled)



WRITE CYCLE NOTE:

1. All write cycle timing is referenced from the last valid address to the first transition address.
2. A write occurs during the overlap of a low \overline{CS} and a low \overline{WE} . A write begins at the latest transition among \overline{CS} going low and \overline{WE} going low: A write ends at the earliest transition among \overline{CS} going high and \overline{WE} going high. t_{wp} is measured from beginning of write to the end of write.
3. t_{cw} is measured from the later of \overline{CS} going low to end of write.
4. t_{as} is measured from the address valid to the beginning of write.
5. t_{wr} is measured from the end of write to the address change. TWR applied in case a write ends as \overline{CS} , or \overline{WR} going high.
6. If \overline{OE} , \overline{CS} and \overline{WE} are in the Read Mode during this period, the I/O pins are in the output low-Z state. Inputs of opposite phase of the output must not be applied because bus contention can occur.
7. For common I/O applications, minimization or elimination of bus contention conditions is necessary during read and write cycle.
8. \overline{IC} \overline{CS} goes low simultaneously with \overline{WE} going low or after \overline{WE} going low, the outputs remain high impedance state.
9. D_{out} is the read data of the new address.
10. When \overline{CS} is low: I/O pins are in the output state. The input signals in the opposite phase leading to the output should not be applied.

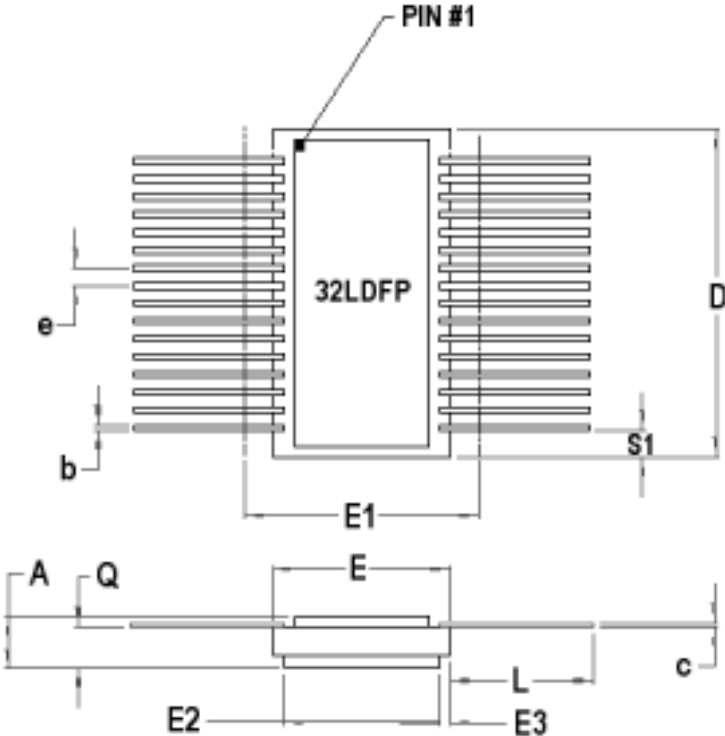

32 PIN RAD-PAK® FLAT PACKAGE

| SYMBOL | DIMENSION | | |
|--------|-----------|-------|-------|
| | MIN | NOM | MAX |
| A | 0.120 | 0.135 | 0.155 |
| b | 0.013 | 0.015 | 0.020 |
| c | 0.008 | 0.010 | 0.012 |
| D | -- | 0.930 | 0.940 |
| E | 0.635 | 0.645 | 0.655 |
| E1 | -- | -- | 0.690 |
| E2 | 0.550 | 0.565 | -- |
| E3 | 0.030 | 0.040 | -- |
| e | 0.050 BSC | | |
| L | 0.390 | 0.400 | 0.410 |
| Q | 0.026 | 0.098 | -- |
| S1 | 0.005 | 0.082 | -- |
| N | 32 | | |

F32-06

Note: All dimensions in inches Important Notice:

4 Megabit (512K x 8-Bit) CMOS SRAM

33C408

These data sheets are created using the chip manufacturers published specifications. **ON** verifies functionality by testing key parameters either by 100% testing, sample testing or characterization.

The specifications presented within these data sheets represent the latest and most accurate information available to date. However, these specifications are subject to change without notice and **ON** assumes no responsibility for the use of this information.

ON' products are not authorized for use as critical components in life support devices or systems without express written approval from **ON**.

Any claim against **ON** must be made within 90 days from the date of shipment from **ON**. **ON**' liability shall be limited to replacement of defective parts.

Product Ordering Options

