

Part/Keyword Search



Detailed Drawing



Printer Friendly Datasheet

## PN9771 / SPN9771\*

\* Part number for additional environmental screening.

### Performance Data

Frequency	1200.0 - 1700.0 MHz
Gain	27.0 dB Typical 25.0 dB Min
Noise Figure	1.0 dB Typical 1.8 dB Max
P <sub>1dB</sub>	15.0 dBm Typical 14.0 dBm Min
3 <sup>rd</sup> Order Intercept	26.0 dBm Typical
2 <sup>nd</sup> Order Intercept	40.0 dBm Typical
VSWR	1.8/2.0 Input Typ/Max 1.8/2.0 Output Typ/Max
Reverse Isolation	-38.0 dB Typical -36.0 dB Min
Power Supply	15.0 Volts 60.0 mA
Operating Temperature	-55.0 - 85.0 °C

### Package Drawing

#### SM-11 (Surface Mount)

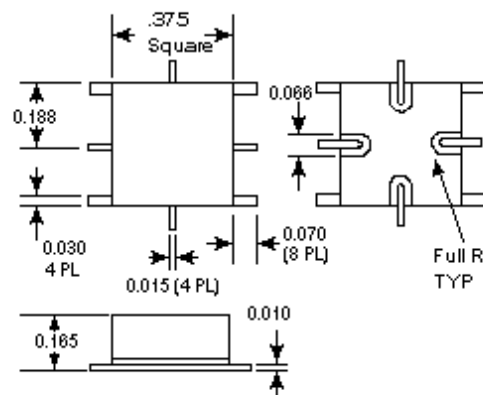

### Gain

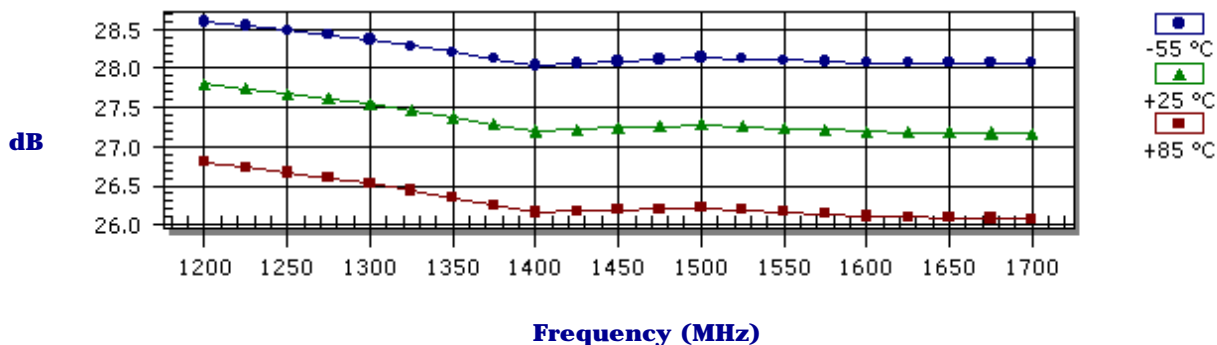

### Noise Figure

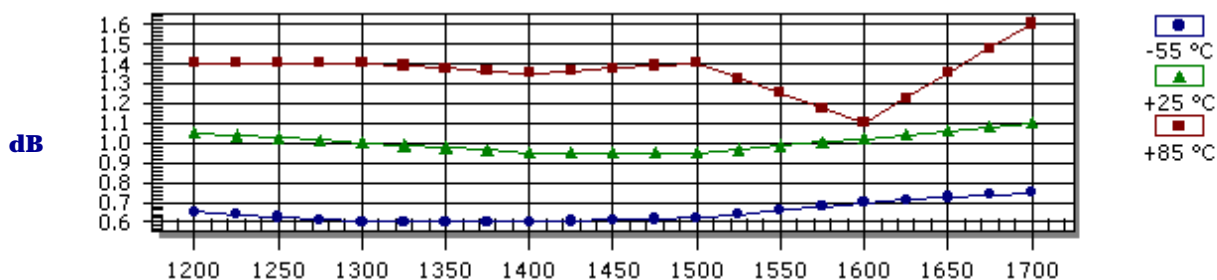

- Products
- Amplifiers
- VCOs
- Limiting Amplifiers
- Switches
- Linearizers
- Limiters
- Analog Attenuators
- Digital Attenuators
- Detectors

Frequency (MHz)

### P<sub>1dB</sub> Compression Point

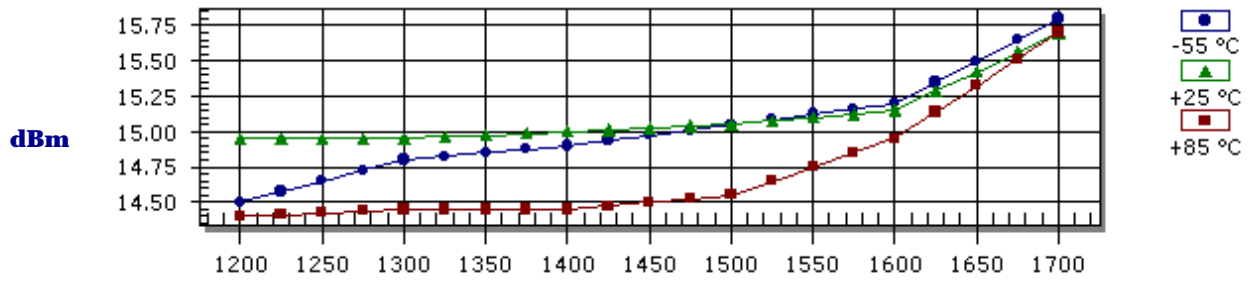

Frequency (MHz)

### Reverse Isolation

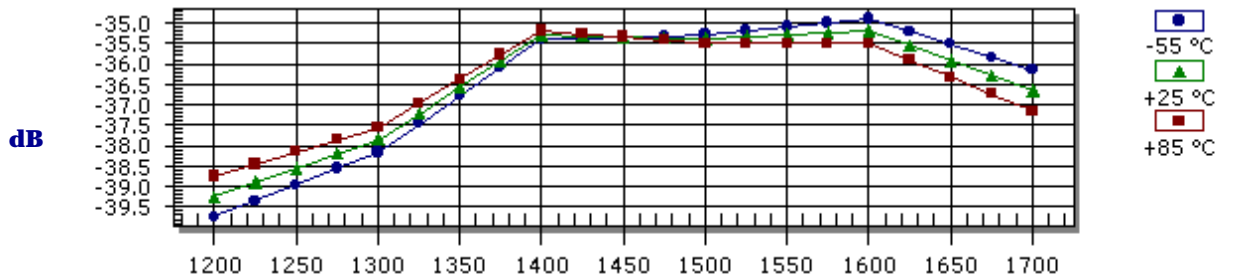

Frequency (MHz)

### Input VSWR

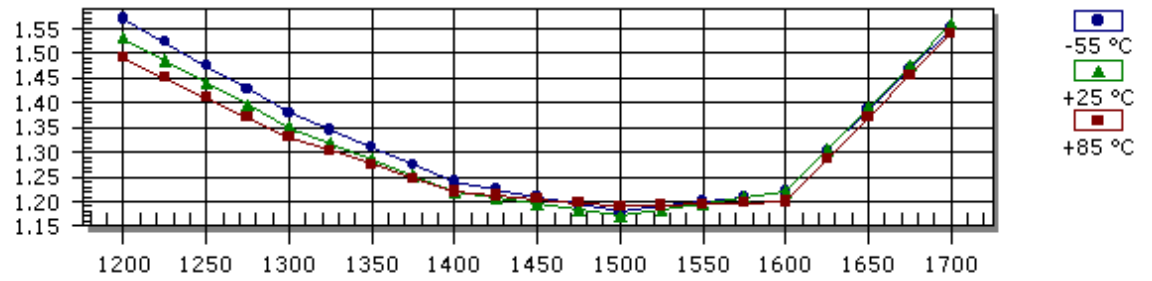

Frequency (MHz)

### Output VSWR

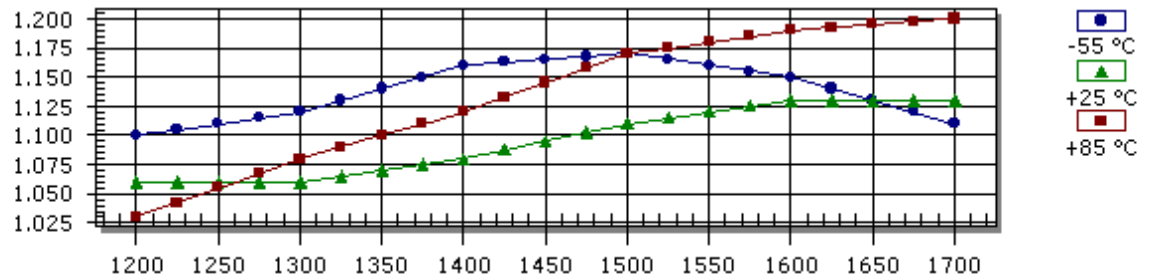

Frequency (MHz)

## S-Parameters

Frequency	S11 Mag	S11 Ang	S21 Mag	S21 Ang	S12 Mag	S12 Ang	S22 Mag	S22 Ang
1200.0	0.210	57.00	24.560	-163.00	0.011	118.00	0.030	-4.00
1300.0	0.150	52.00	23.860	171.00	0.013	96.00	0.030	-37.00
1400.0	0.100	51.00	22.900	146.00	0.017	79.00	0.040	-69.00
1500.0	0.080	36.00	23.130	121.00	0.017	54.00	0.050	-101.00
1600.0	0.100	11.00	22.890	93.00	0.017	32.00	0.060	-128.00
1700.0	0.220	-28.00	22.820	61.00	0.015	-5.00	0.060	-164.00

## Absolute Maximum Conditions

Maximum Operating Temperature	-55.0 - 100.0 °C	Maximum Storage Temperature	-62.0 - 125.0 °C
Maximum Case Temperature	125.0 °C	Maximum Supply Voltage	18.0 Volts
Continuous RF Input Power	13.0 dBm	Short Term RF Input Power (1 minute max)	200.0 mW
Maximum Peak Power (3 µsec max)	0.5 W		

Amplifonix | 2707 Black Lake Place | Philadelphia, PA 19154  
Tel: 215.464.4000 | FAX: 215.464.4001 | Email: [info@amplifonix.com](mailto:info@amplifonix.com)

# i2 Technologies US, Inc.

## HTML Pages converted to PDF Document

This document contains component information from the manufacturer's website which are not available in a revision controlled document from the manufacturer. To facilitate the addition of these parts into the Electronics Database, we are converting the HTML pages related to that part, from the manufacturer's website into Adobe PDF format. The contents of this document is based on the information provided on the manufacturer's website, therefore the information may have been changed by the manufacturer since this was created.

