



Quad Port 8.5 Gbps to 11.3 Gbps CDR with EDC

Vitesse's new high-performance clock and data recovery (CDR) IC provides superior signal integrity, speed flexibility, programmable output, and integrated diagnostics for optical applications

Highlights

- Broad application support
- High-performance analog EDC
- High-density receiver

Applications

- Long-haul SMF platforms
- FEC-enabled systems
- 40G/100G CFP module designs:
4×10G, 10×10G, and 10×12G

The VSC8247 is a quad channel clock and data recovery (CDR) receiver with on-chip adaptive electronic dispersion compensation (EDC), programmable input equalization, and selectable pre-emphasis output.

Operating at 8.5 Gbps to 11.3 Gbps, the VSC8247 is a versatile CDR and retimer for all 10G Ethernet and SONET applications. VSC8247 also supports 8G Fibre Channel and 10G QDR Infiniband protocols and data rates, and all legacy rates. The VSC8247's flexibility makes it an excellent candidate for upcoming 4×10G and 10×10G CFP modules and high-density photonic integrated circuit (PIC) designs.

Integrated EDC compensates for signal degradations in both the optical and electrical domains. For optical systems, this includes chromatic dispersion in long-haul single mode fiber systems, and modal dispersion in multimode fiber systems. High-performance FFE-DFE EDC technology compensates for fiber signal impairment and PCB-related signal degradation. Feedback from an FEC device can be used for further optimization and enhanced performance.

Each channel includes an independent VScope™ input signal monitoring integrated circuit and built-in error detector to facilitate product design, production, and deployment.

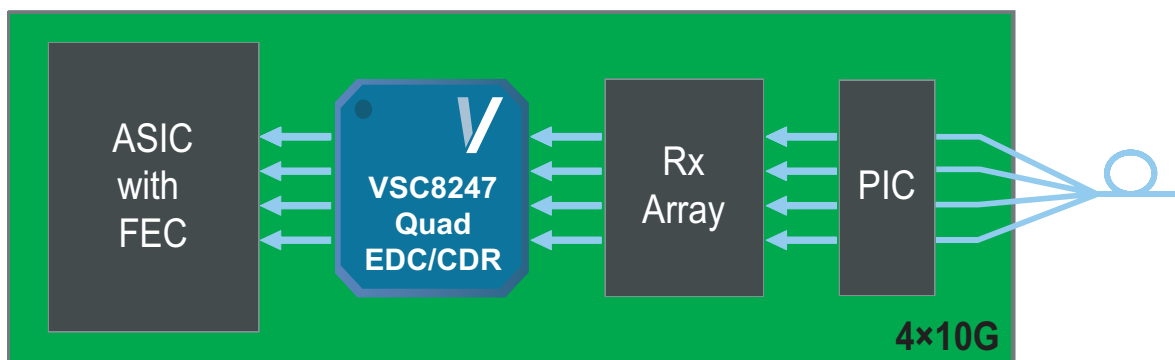

Linecard

Flexibility

- MDIO, two-wire serial master, and two-wire serial slave interfaces
- Embedded microcontroller with on-board RAM for reduced system chip count
- Rx EDC programmable to user-defined values or adaptive mode operation
- Output pre-emphasis and signal programming for optimized signal integrity
- VScope input signal monitoring integrated circuit for optimal eye opening and lower BER
- Power-on reset initializes default mode independently of the serial interface
- Independent per-channel operation and power-down

Key Specifications

- 1.8 V and 1.2 V typical core power supplies (1.2 V to 3.3 V TTL supply)
- 13 mm × 13 mm, 144-pin FCBGA package

Wide Range of Support

- 8.5G to 11.3G Ethernet
- Legacy 1.25G Ethernet, 2G and 4G Fibre Channel, and 2.5G and 5G Infiniband
- Compliant with IEEE 802.3aq, IEEE 802.3ae, SFF-8431 (SFI), and GR-253 electrical specifications

Related Vitesse Products

Visit www.vitesse.com for information about these related Vitesse products:

- VSC3144 6.5 Gbps or 10.709 Gbps 144 × 144 Asynchronous Crosspoint Switch
- VSC3316 11.5 Gbps 16 × 16 Crosspoint Switch and Signal Conditioner
- VSC7878 10 Gbps Linear Transimpedance Amplifier
- VSC7987 10 Gbps Multirate Limiting Post Amplifier

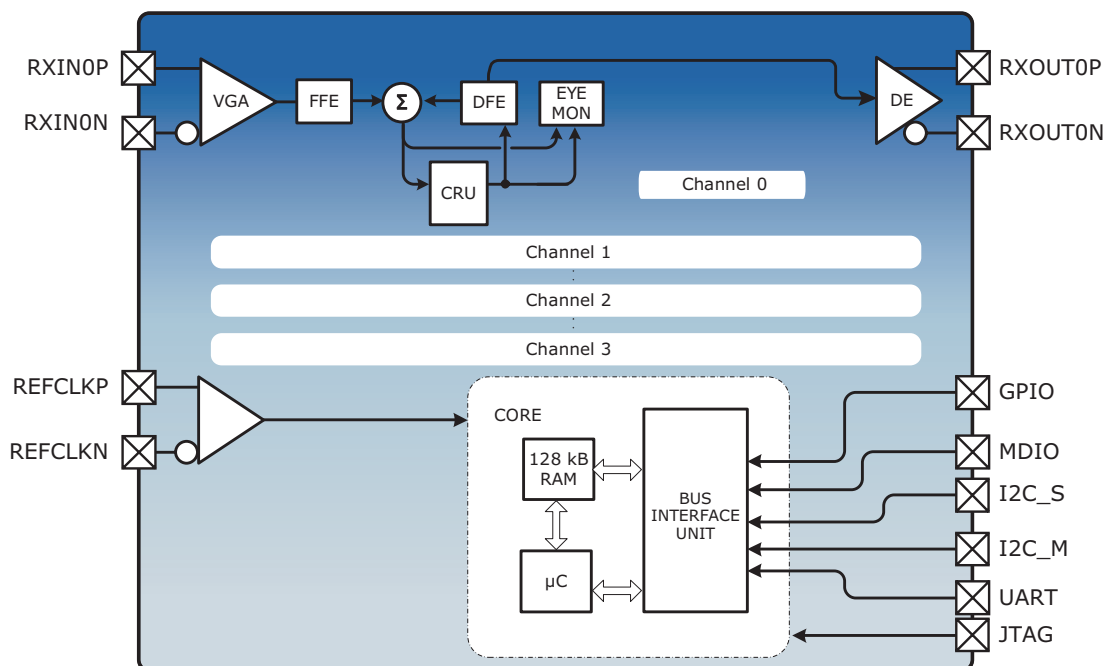

Vitesse Semiconductor Corporation

741 Calle Plano • Camarillo, CA 93012 USA • Tel: +1.800.VITESSE • +1.805.388.3700 • Fax: +1.805.987.5896 • www.vitesse.com

© 2010 by Vitesse Semiconductor Corporation. VPPD-02560 Revision 1.0. Vitesse Semiconductor Corporation ("Vitesse") retains the right to make changes to its products or specifications. As such, all information in this document, including descriptions of features, functions, performance, technical specifications and availability, is subject to change without notice at any time, and Vitesse assumes no responsibility for use of any information herein. Nothing contained herein conveys to the purchaser of microelectronic devices any license under the patent or any other intellectual property rights of any manufacturer. Vitesse®, and numerous other trademarks, are trademarks of Vitesse in the United States and/or other jurisdictions. Other trademarks used herein that are not the property of Vitesse are the property of their respective owners. While Vitesse products support IEC 60825, use of Vitesse products does not ensure compliance to IEC 60825. Buyers are responsible for ensuring compliance to IEC 60825. Buyers must fully indemnify Vitesse for any damages resulting from non-compliance to IEC 60825.