

# ENGINEERING DATA SHEET

# M500

RELAY - NONLATCH  
3 PDT, 25 AMP

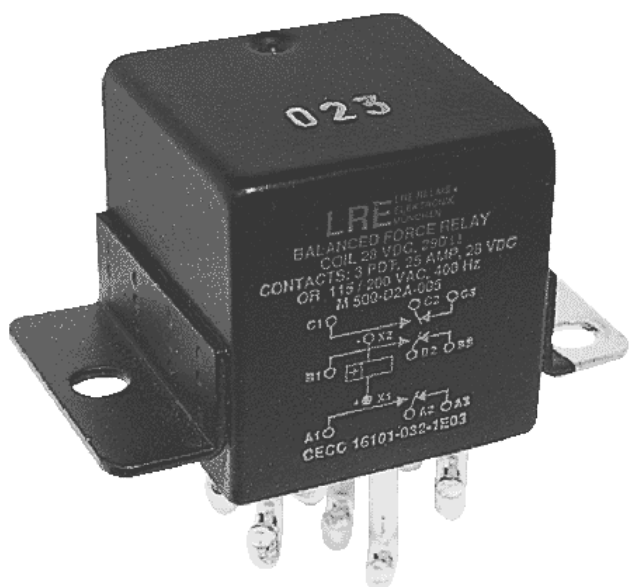

**APPLICATION NOTES:**

- [001](#)
- [007](#)
- [023](#)

**APPLICABLE SOCKET:**

- [S500](#)

Polarized, non latching hermetically sealed relay  
 Contact arrangement **3 PDT**  
 Coil supply **Direct current**  
 Meets the requirements of **MS27743**  
 Qualified to **CECC16101-032**  
**CECC16103-805**

**PRINCIPLE TECHNICAL CHARACTERISTICS**

Contacts rated at **28 Vdc; 115 Vac, 400 Hz**  
 Weight **85 grams max**  
 Dimensions max. of case in mm **26 x 25.4 x 26**  
 Balanced-force design  
 Hermetically sealed, corrosion protected metal can

**CONTACT ELECTRICAL CHARACTERISTICS**

Minimum operating cycles	Contact rating per pole and load type	Load Current in Amps		
		@28 Vdc	@115 Vac, 400 Hz	@115/200 Vac, 400 Hz
50,000 cycles	resistive load	25	25	25
10,000 cycles	inductive load (L/R=5ms)	12	12	12
50,000 cycles	motor load	10	10	10
50,000 cycles	lamp load	5	5	5
50 cycles	resistive overload	50	80	
200,000 cycles	at 25% rated resistive load			



Featuring **LEACH**® power and control solutions  
[www.esterline.com](http://www.esterline.com)

**AMERICAS**  
 6900 Orangethorpe Ave.  
 P.O. Box 5032  
 Buena Park, CA 90622

Tel: (01) 714-736-7599  
 Fax: (01) 714-670-1145

**EUROPE**  
 2 Rue Goethe  
 57430 Sarralbe  
 France

Tel: (33) 3 87 97 31 01  
 Fax: (33) 3 87 97 96 86

**ASIA**  
 Units 602-603 6/F Lakeside 1  
 No.8 Science Park West Avenue  
 Phase Two, Hong Kong Science Park  
 Pak Shek Kok, Tai Po, N.T.  
 Hong Kong  
 Tel: (852) 2 191 3830  
 Fax: (852) 2 389 5803

Data sheets are for initial product selection and comparison. Contact Esterline Power Systems prior to choosing a component.

**COIL CHARACTERISTICS (Vdc)****M500**

CODE	A	B	C	N
Nominal operating voltage	28	12	6	28
Maximum operating voltage	29	14.5	7.3	29
Maximum pick-up voltage at +125° C	18	9	4.5	18
Maximum drop-out voltage at -65° C	1.5	0.7	0.35	1.5
Coil resistance $\Omega \pm 10\%$ at +25° C	290	70	18	290
Back EMF suppressed to (Vdc)	N/A	N/A	N/A	-42

**GENERAL CHARACTERISTICS**

Temperature range	-65°C to +125°C
Dielectric strength at sea level	
- Contacts to ground and between contacts	1250 Vrms / 50 Hz
- Coil to ground	1000 Vrms / 50 Hz
Dielectric strength at altitude 25,000 m (all points)	350 Vrms / 50 Hz
Initial insulation resistance at 500 Vdc	100 M $\Omega$ min.
Sinusoidal vibration (except G and O mounting)	30G / 75 to 3000 Hz
Sinusoidal vibration (G and O mounting only)	20G / 75 to 3000 Hz
Shock (except G and O mounting)	200G / 6 ms
Shock (G and O mounting only)	50G / 11 ms
Maximum contact opening time under vibration and shock	10 $\mu$ s
Operate time at nominal voltage	15 ms max
Release time	15 ms max
Bounce time	1 ms max
Contact voltage drop at nominal current	
- initial value	150 mV max
- after life	175 mV max

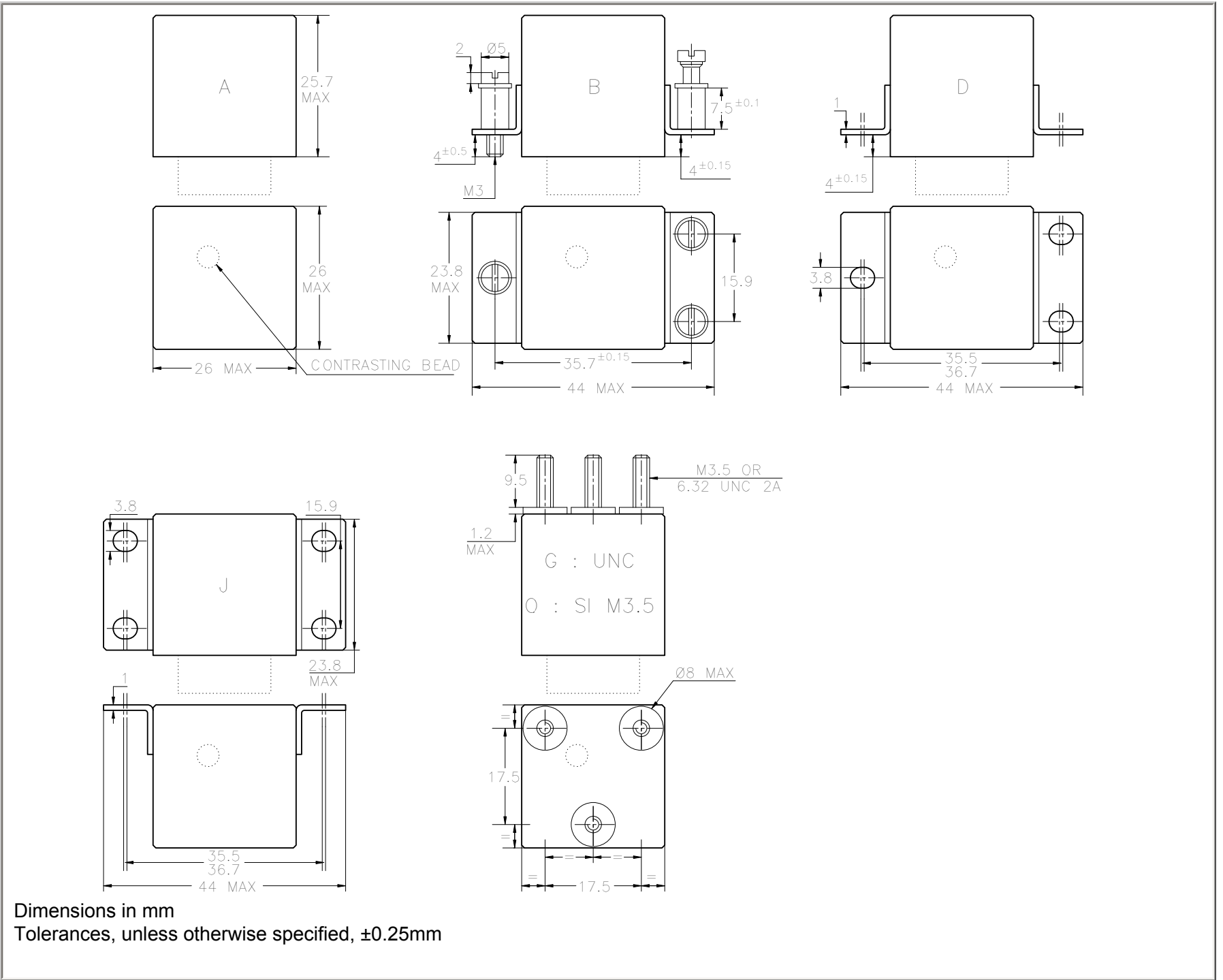

**TERMINAL TYPES**

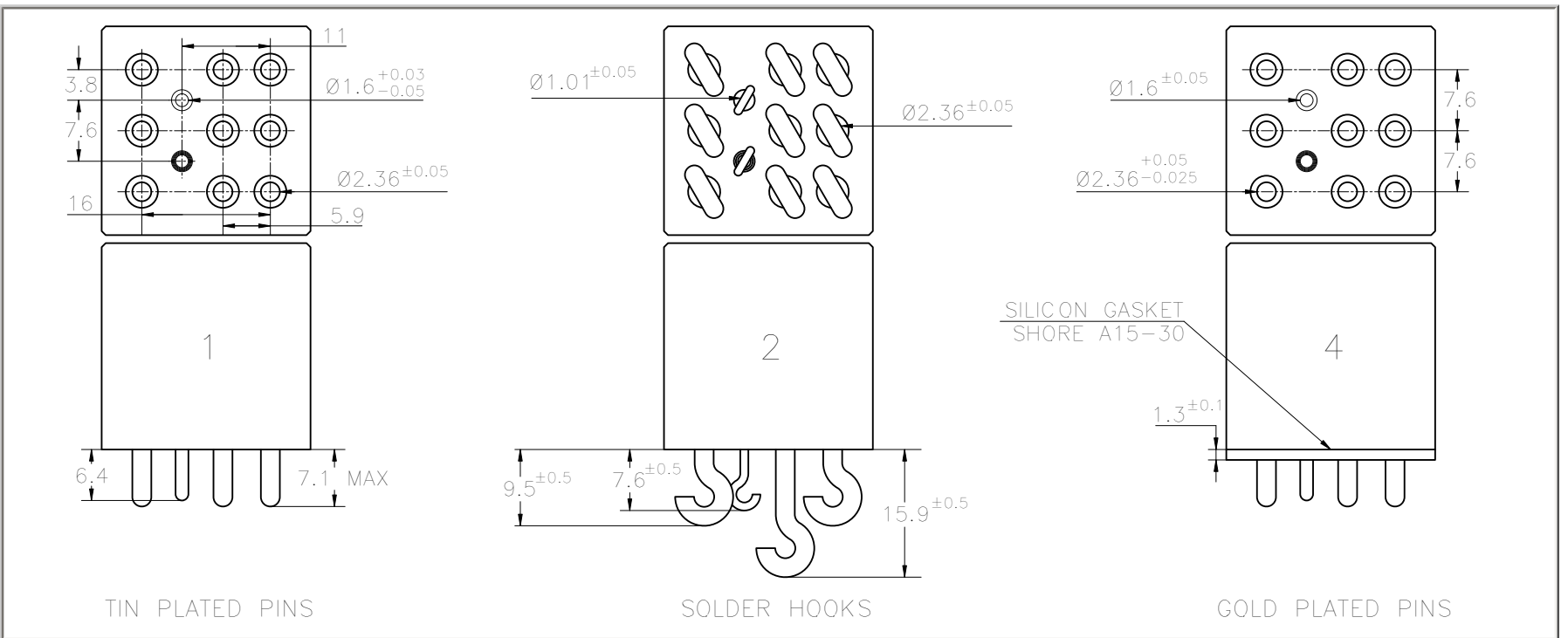

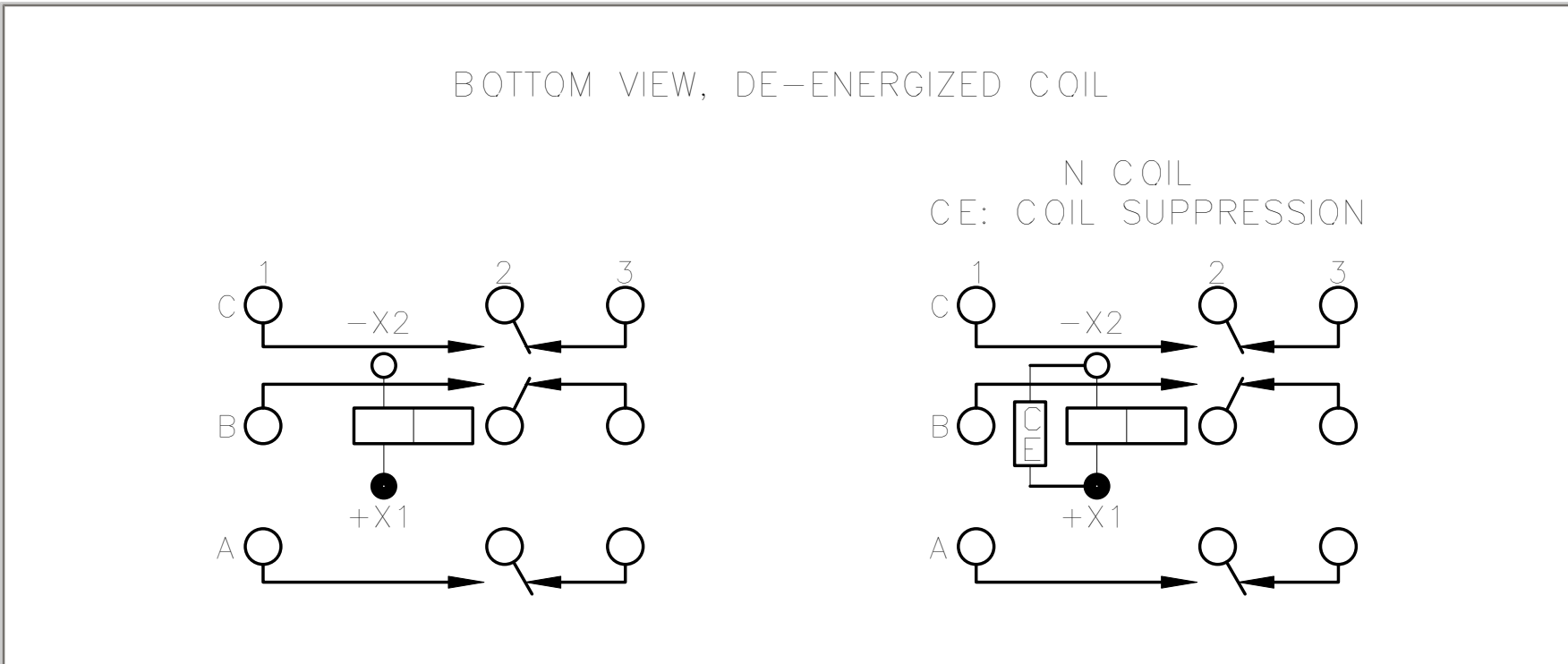

**NUMBERING SYSTEM**

	M500	A	1	A	C	ER
Basic series designation _____						
1-Mounting Style (A,B,D,G,J,O) _____						
2-Terminal Types (1,2,4) _____						
3-Coil Voltage (A,B,C,N) _____						
4-See Note [4] Below _____						
5-See Note [5] Below _____						

**NOTES**

1. Relays with mounting styles B,D and terminal type 4 are compatible with socket families S500...
  2. Isolation spacer pads for PCB mounting available on request.
  3. For other mounting styles or terminal types, please contact the factory.
- [4]. **Options**
- **C**: Circuit breaker compatibility 30 A / 1 hour; 50 A / 5 sec; 100 A / 1.2 sec 250 A / 0.2 sec; 350 A / 0.1 sec
  - **D**: low level: 10  $\mu$ A / 10 mV
- [5]. Quality level:
- **D005**: Model qualified to CECC16101-031
  - **D006**: Model qualified to CECC16103-809
  - **ER**: Please contact factory.

**TYPICAL CHARACTERISTICS**

- Coil resistance/temperature change: See application note no. 001

**CORRECTION DUE TO COIL COPPER WIRE RESISTANCE  
CHANGE IN TEMPERATURE**

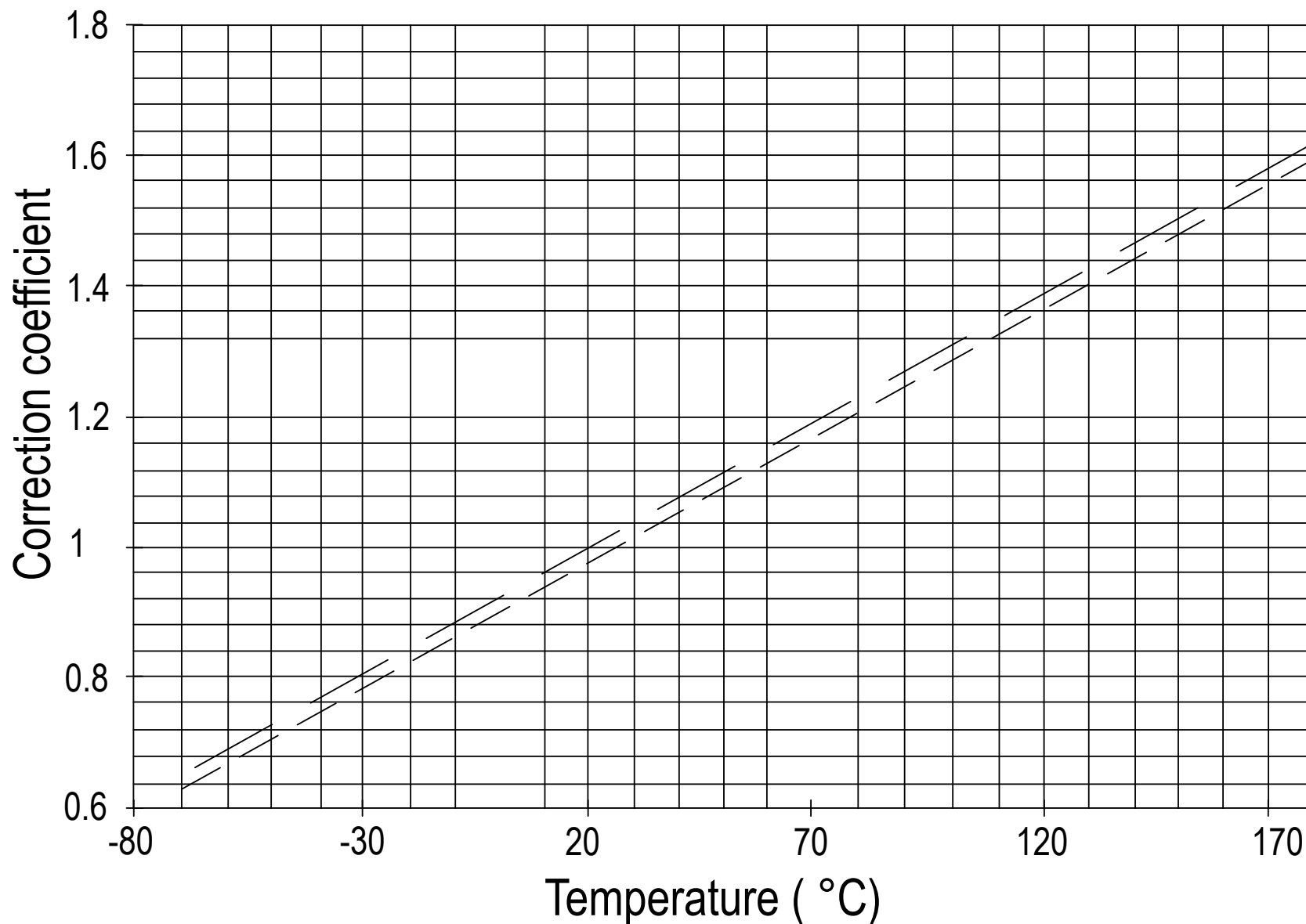

— — Nominal Resistance at 25°C

———— Nominal Resistance at 20°C

Example: Coil resistance at 25°C: 935 ohms. What is it at 125°C?

Correction coefficient on diagram is: 1.39 at 125°C. R becomes:  $935 \times 1.39 = 1299$  Ohms

Correction also applies to operating voltages

**SUPPRESSOR DEVICES FOR RELAY COILS**

The inductive nature of relay coils allows them to create magnetic forces which are converted to mechanical movements to operate contact systems. When voltage is applied to a coil, the resulting current generates a magnetic flux, creating mechanical work. Upon deenergizing the coil, the collapsing magnetic field induces a reverse voltage (also known as back EMF) which tends to maintain current flow in the coil. The induced voltage level mainly depends on the duration of the deenergization. The faster the switch-off, the higher the induced voltage.

All coil suppression networks are based on a reduction of speed of current decay. This reduction may also slow down the opening of contacts, adversely effecting contact life and reliability. Therefore, it is very important to have a clear understanding of these phenomena when designing a coil suppression circuitry.

**Typical coil characteristics**

On the graph below, the upper record shows the contacts state. (High level NO contacts closed, low level NC contacts closed, intermediate state contact transfer). The lower record shows the voltage across the coil when the current is switched off by another relay contact.

The surge voltage is limited to -300V by the arc generated across contact poles. Discharge duration is about 200 microseconds after which the current change does not generate sufficient voltage. The voltage decreases to the point where the contacts start to move, at this time, the voltage increases due to the energy contained in the NO contact springs. The voltage decreases again during transfer, and increases once more when the magnetic circuit is closed on permanent magnet.

- Operating times are as follows:
- Time to start the movement 1.5ms
- Total motion time 2.3ms
- Transfer time 1.4ms

Contact State

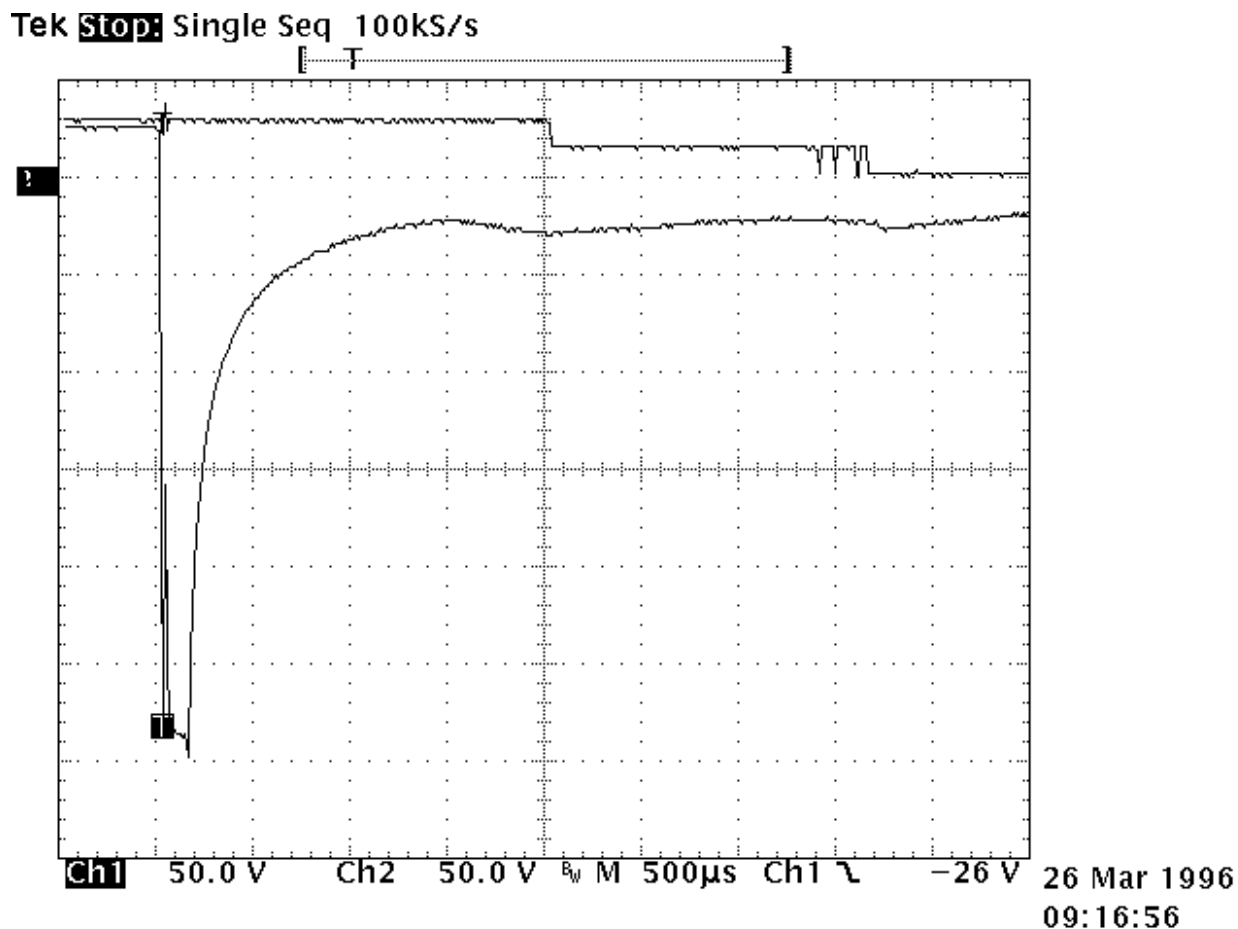

## Types of suppressors:

### Passive devices.

#### The resistor capacitor circuit

It eliminates the power dissipation problem, as well as fast voltage rises. With a proper match between coil and resistor, approximate capacitance value can be calculated from:

$$C = 0.02 \times T / R, \text{ where}$$

T = operating time in milliseconds

R = coil resistance in kiloOhms

C = capacitance in microFarads

The series resistor must be between 0.5 and 1 times the coil resistance. Special consideration must be taken for the capacitor inrush current in the case of a low resistance coil.

The record shown opposite is performed on the same relay as above. The operation time becomes:

- time to start the movement 2.3ms

- transfer time 1.2ms

The major difficulty comes from the capacitor volume. In our example of a relay with a  $290 \Omega$  coil and time delay of 8 ms, a capacitance value of  $C=0.5 \mu\text{F}$  is found. This non polarized capacitor, with a voltage of 63V minimum, has a volume of about  $1\text{cm}^3$ . For 150V, this volume becomes  $1.5 \text{cm}^3$ .

Tek **Stop**: Single Seq 100kS/s

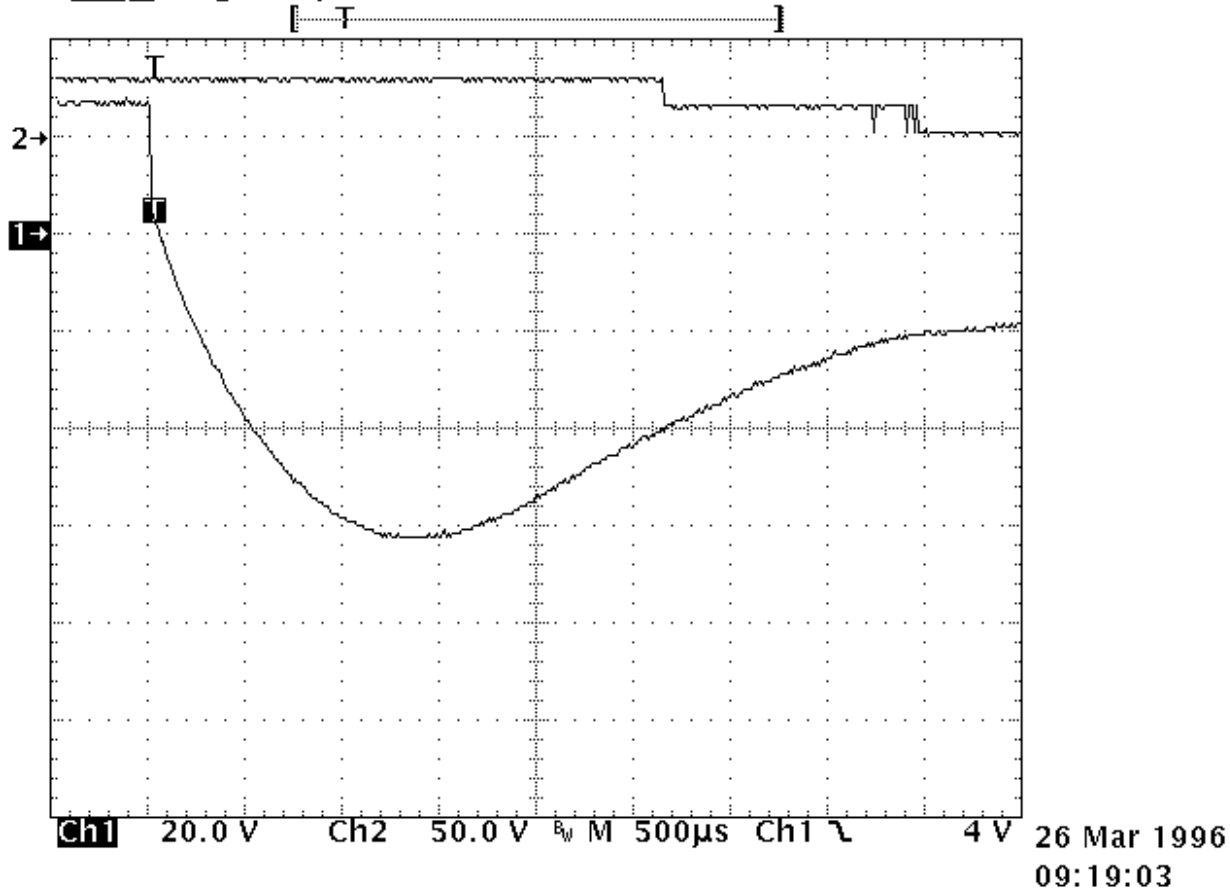

### The bifilar coil

The principle is to wind on the magnetic circuit of the main coil a second coil shorted on itself. By a proper adaptation of the internal resistance of this second coil it is possible to find an acceptable equilibrium between surge voltage and reduction of the opening speed. To be efficient at fast voltage changes, the coupling of two coils must be perfect. This implies embedded windings. The volume occupied by the second coil reduces the efficiency of the main coil and results in higher coil power consumption. This method cannot be applied efficiently to products not specifically designed for this purpose.

### The resistor (parallel with the coil)

For efficient action, the resistor must be of the same order of magnitude as the coil resistance. A resistor 1.5 times the coil resistance will limit the surge to 1.5 times the supply voltage. Release time and opening speed are moderately affected. The major problem is the extra power dissipated.

### **Semi-conductor devices**

#### The diode

It is the most simple method to totally suppress the surge voltage. It has the major disadvantage of the higher reduction of contact opening speed. This is due to the total recycling, through the diode, of the energy contained in the coil itself. The following measurement is performed once again on the same relay. Operation times are given by the upper curve:

- time to start the movement 14ms
- transfer time 5ms

These times are multiplied by a coefficient from 4 to 8.

The lower curve shows the coil current. The increase prior to NO contact opening indicates that the contact spring dissipates its energy. At the opening time the current becomes constant as a result of practically zero opening speed.

Due to this kind of behavior, this type of suppression must be avoided for power relays. For small relays which have to switch low currents of less than 0.2 A, degradation of life is not that significant and the method may be acceptable.

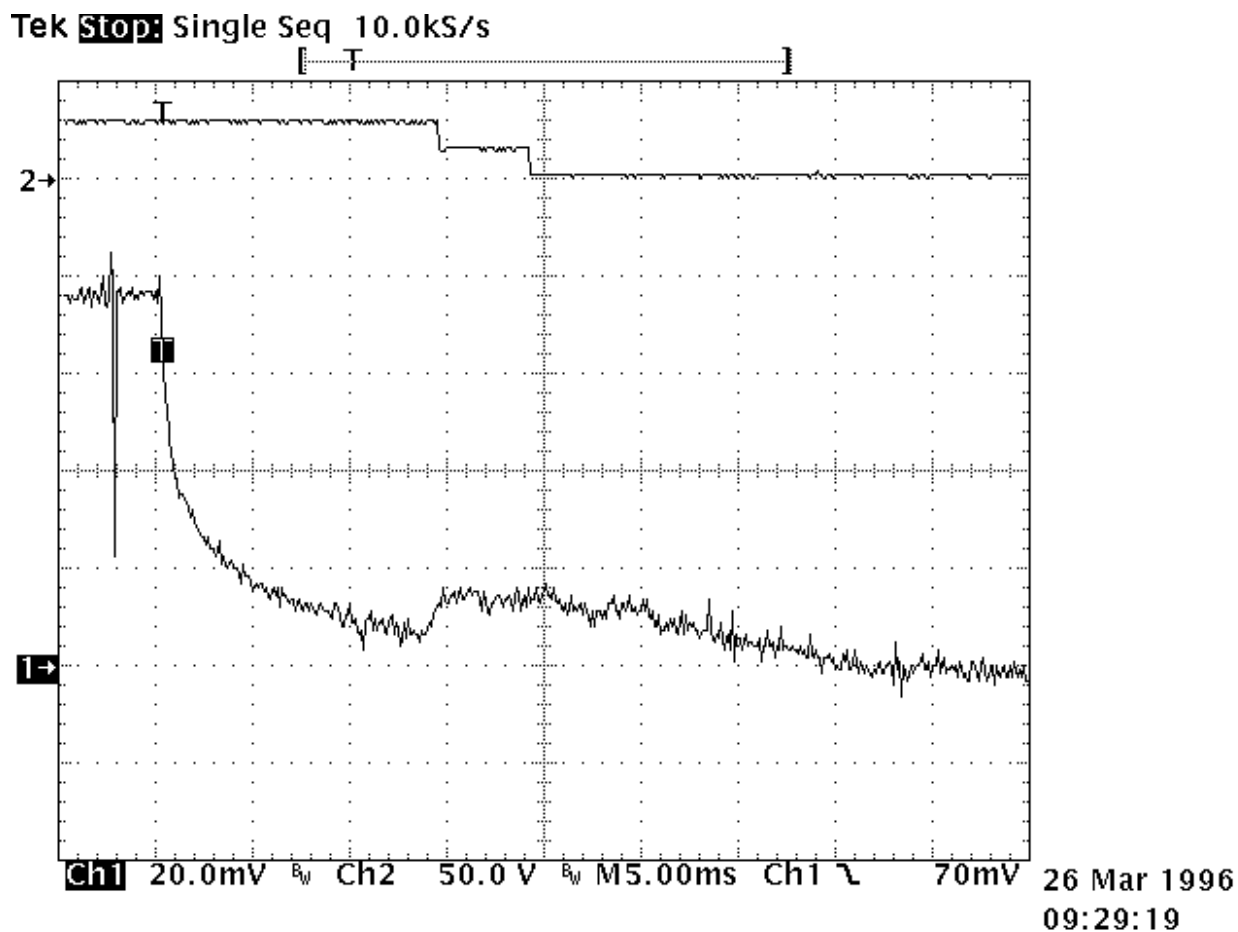

### The diode + resistor network

It eliminates the inconvenience of the resistor alone, explained above, and it limits the action of a single diode. It is now preferred to use the diode + zener network.

### The diode + zener network

Like the resistor, the zener allows a faster decurrent decay. In addition it introduces a threshold level for current conduction which avoids the recycling of energy released during contact movement.

The lower curve on the opposite record demonstrates those characteristics. Voltage limitation occurs at 42V. The two voltage spikes generated by internal movement are at lower levels than zener conduction. As a result, no current is recycled in the coil.

The opening time phases are as follows:

- time to start the movement 2.6ms
- total motion time 2.4ms
- transfer time 1.4ms

The release time is slightly increased. The contacts' opening speed remains unchanged.

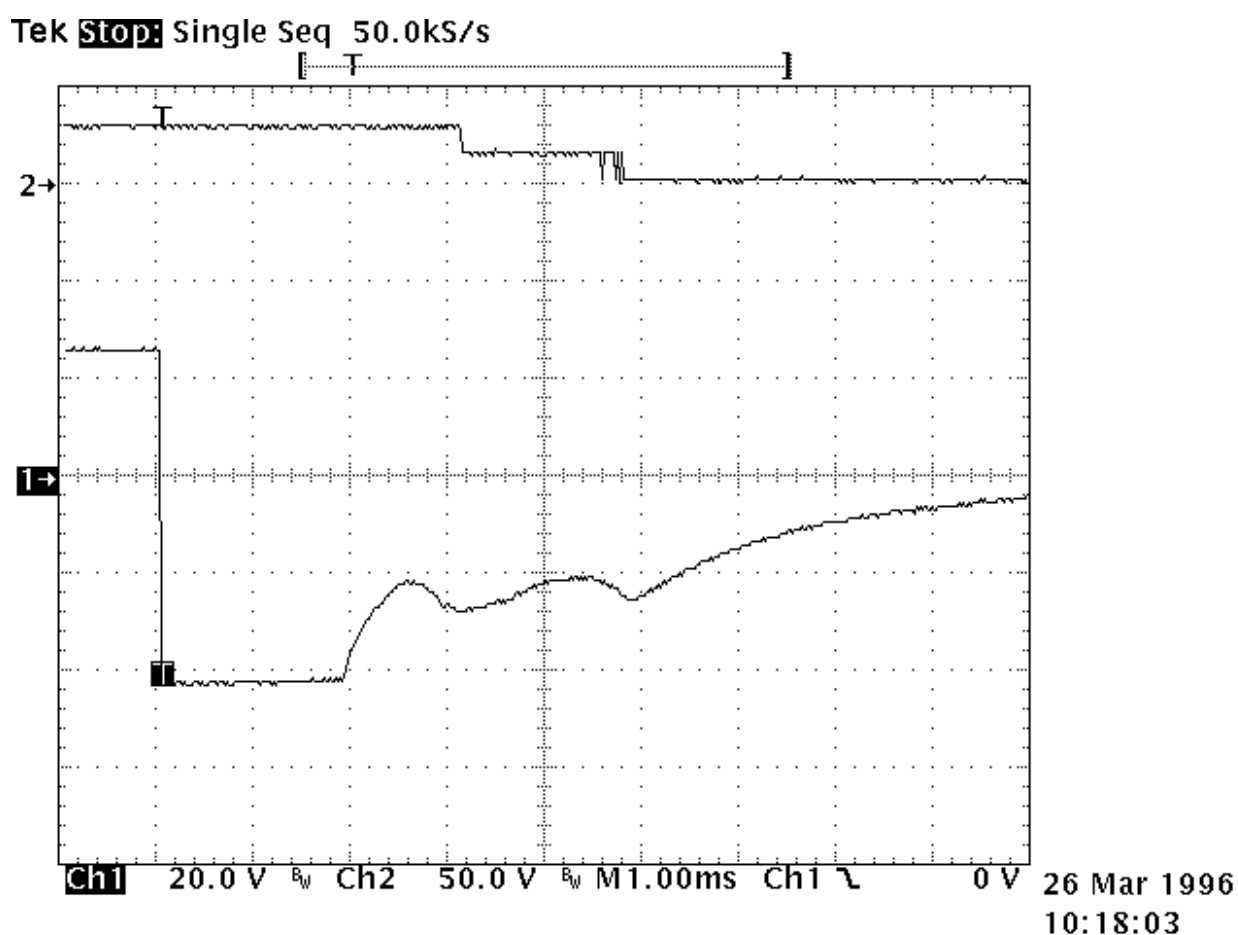

**MOUNTING DISTANCE BETWEEN RELAYS**  
**Applicable to M2XX / M3XX / M4XX / M5XX**

**Definition and applicability**

This application note defines the minimum distance between relays to maintain the whole performances of the relays as given in our data sheets.

**Phenomenon analysis**

Each relay generates a magnetic field either when relay is de-energised because of the permanent magnet or in the energised position because of permanent magnet and coil. The magnetic field generated by one relay could affect the performance of another relay when the below minimum distance between relay is not respected. If the relays are mounted adjacent to each other, it is advisable to alternate direction of magnetic path on every other unit and to keep a 1.6 mm space between relays, figure "A". Or when mounted in the same direction, separate each relay from the other by 3.2 mm, figure "B". If two or more rows of relays are installed, allow clearance of 3.2 mm between rows, figures "C" and "D". Provide 4.8 mm space between relays if used in opposition, figure "E". Distance in millimetre.

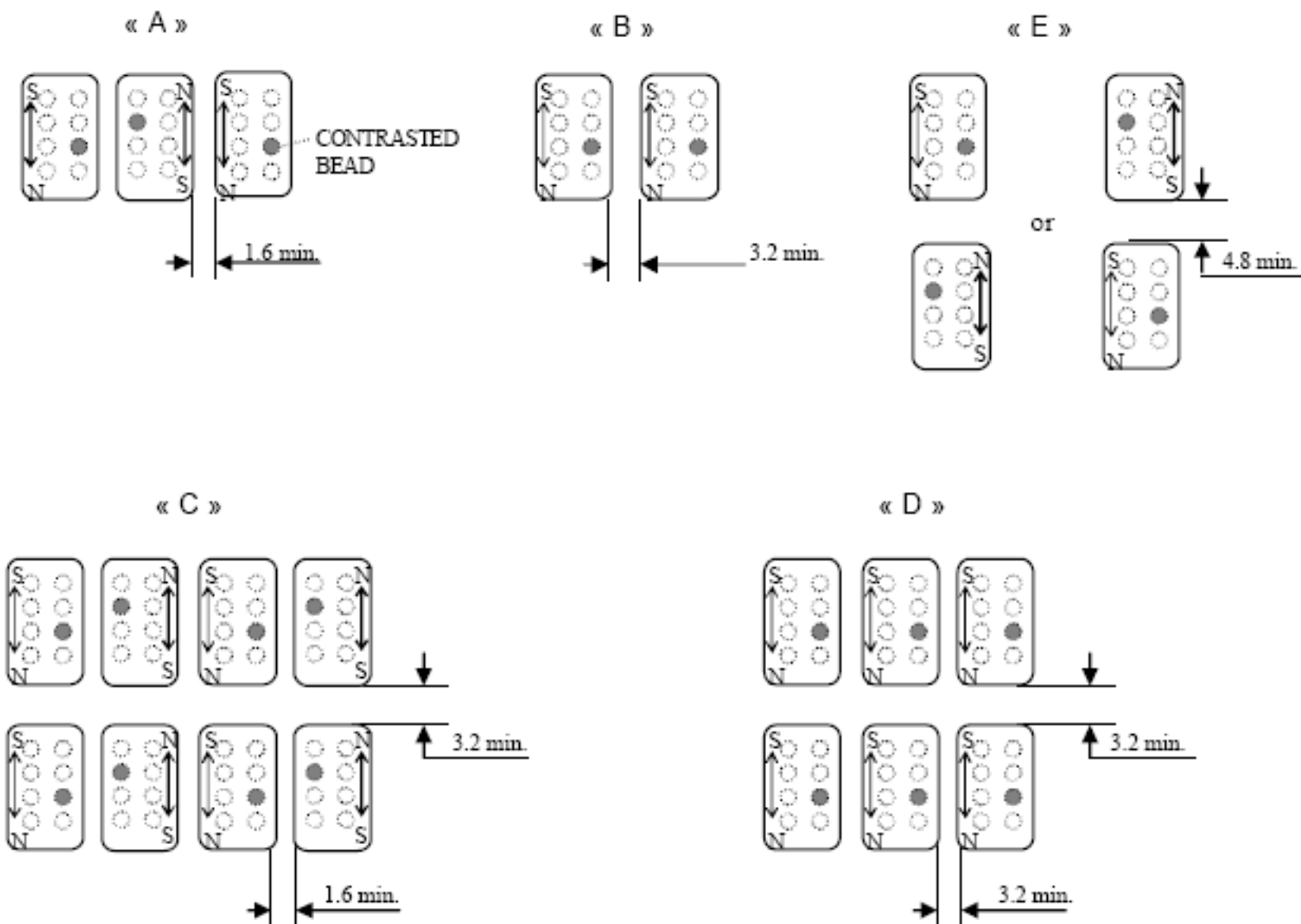

# S500, S501, S502, S550

## ENGINEERING DATA SHEET

RELAY SOCKET  
25 AMP

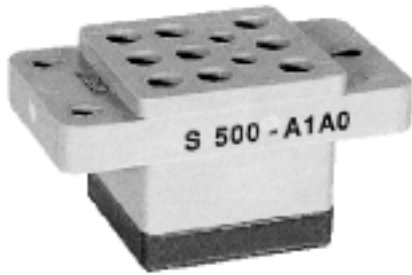

BASIC SOCKET SERIES DESIGNATION FOR:

**SERIES M500 (DC Coil), M501 (AC Coil),  
M502 (DC Coil), M550 (DC Coil), T531, CS500**

DESIGNED TO THE STANDARDS AND REQUIREMENTS OF:

**MIL-PRF-12883/48 & /54**

### DIMENSIONS

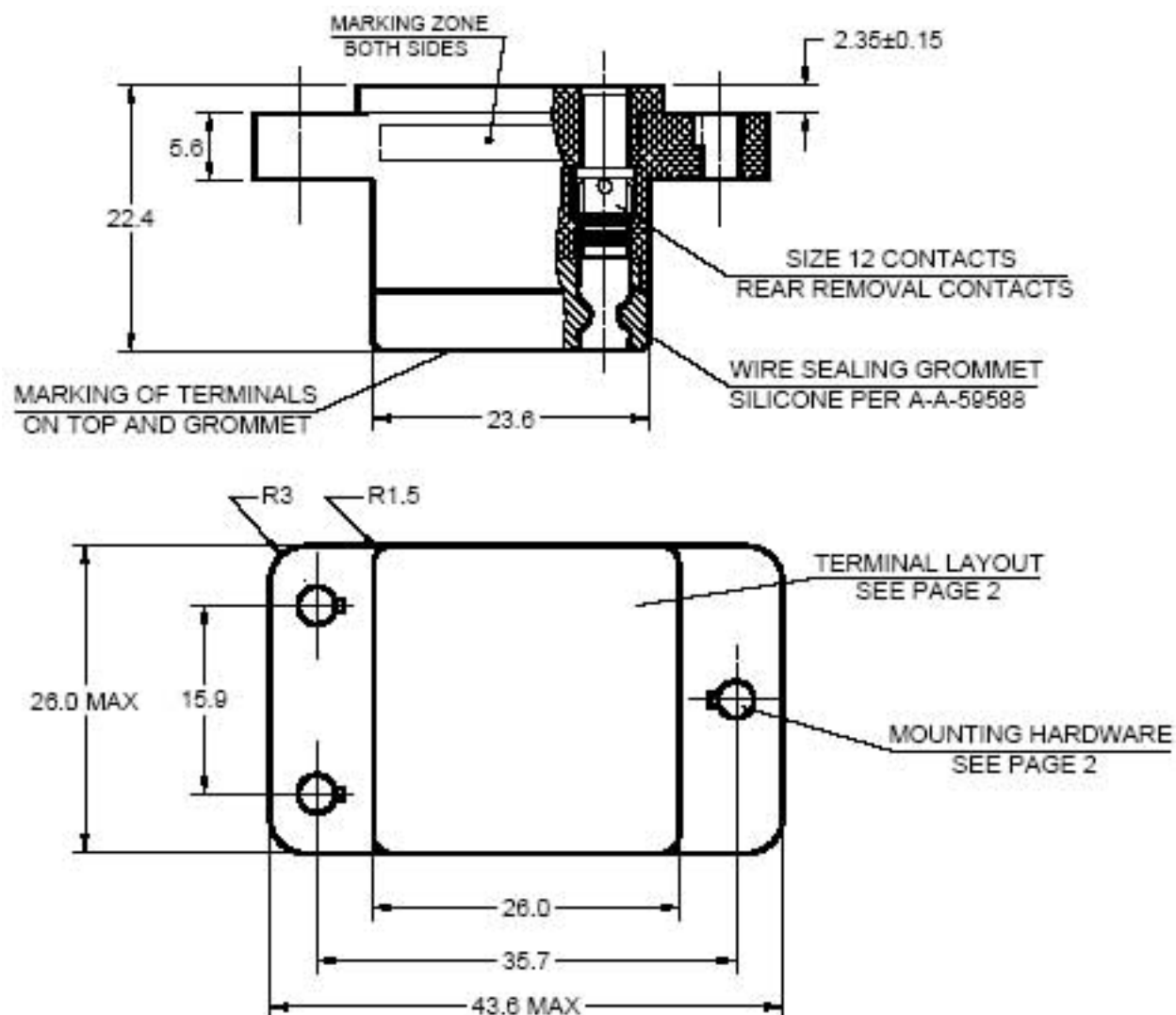

### GENERAL CHARACTERISTICS

Crimp tool for contacts	M 22520/1-01, Positioner M22520/1-02
Insertion / removal tool	#16: M81969/14-03 #12: M81969/14-04
Weight	45 grams Max
Temperature range	-70°C to +125°C
Contact and mounting hardware supplied in a separate plastic bag. Standard tolerances, ±0.25mm	



Featuring **LEACH**® power and control solutions

[www.leachintl.com](http://www.leachintl.com)

Data sheets are for initial product selection and comparison. Contact Leach International prior to choosing a component.

**AMERICAS**  
6900 Orangethorpe Ave.  
P.O. Box 5032  
Buena Park, CA 90622 USA

Tel: (01) 714-736-7599  
Fax: (01) 714-670-1145

**EUROPE**  
2 Rue Goethe  
57430 Sarralbe  
France

Tel: (33) 3 87 97 31 01  
Fax: (33) 3 87 97 96 86

**ASIA**  
Room 501, 5/F, The Centre Mark  
287 - 299 Queen's Road Central  
Hong Kong

Tel: (852) 2 191 3830  
Fax: (852) 2 389 5803

# TERMINAL LAYOUT

S500, S501, S502

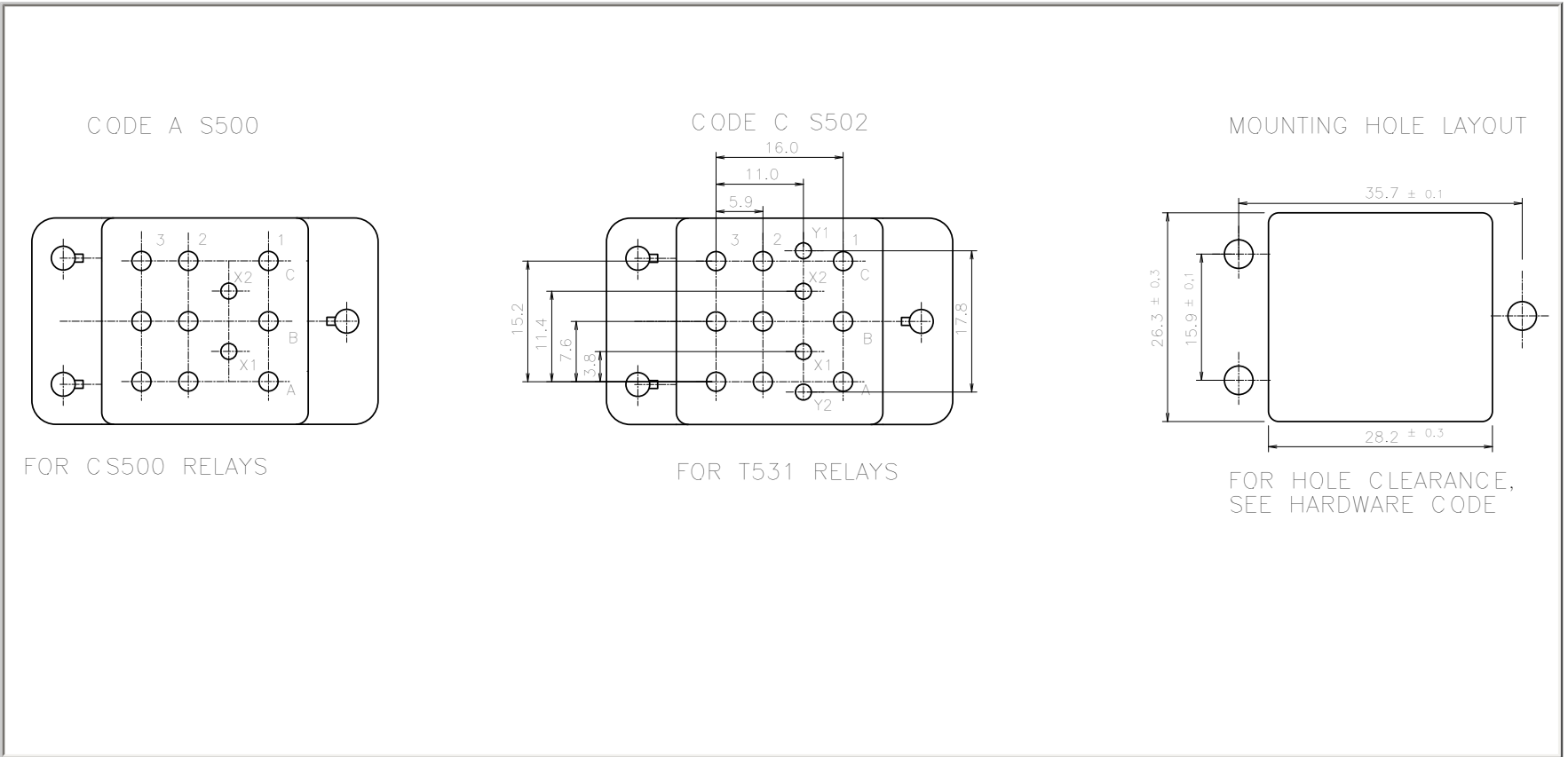

# MOUNTING HARDWARE

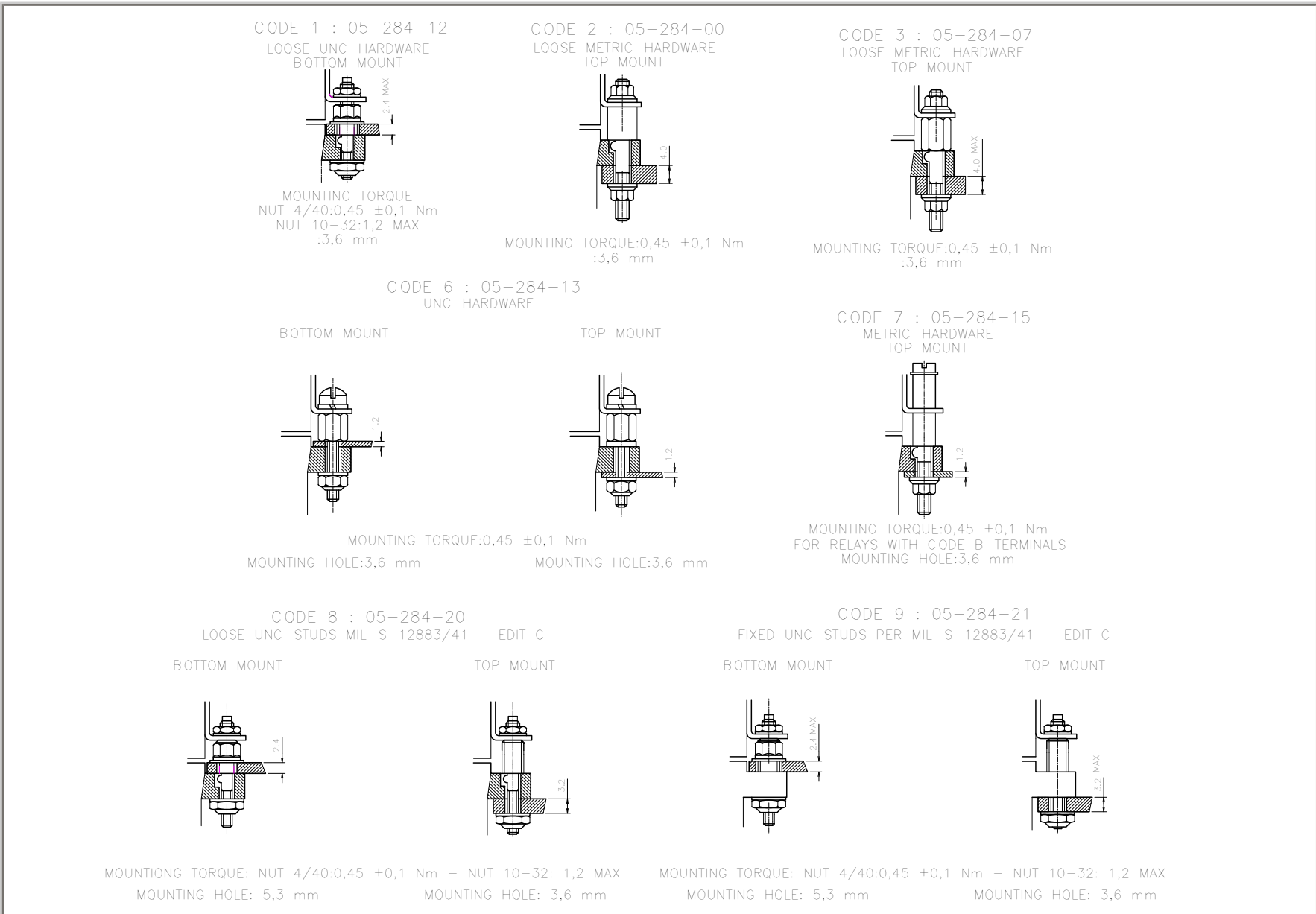

Code A	Dia: 2.8 .....3.4mm
--------	---------------------

**CONTACT SIZE AND STYLE**

<p>Y1 - Y2 Crimp end to accommodate AWG 20-20-24 05 913 00 (for contact code 8 +10) <u>Contact mating end #20</u></p>	<p>Code 8 Crimp end to accommodate 05 910 00 AWG12-14 <u>Contact mating end #12</u></p>	<p>Code 10 Crimp end to accommodate 05 910 01 AWG16 <u>Contact mating end #12</u></p>
<p>31 236 00 (for contact code 11 + 13) MIL-C-3902/92-532 Bin Code color bands or Bin Code numbering on crimpside <u>Contact mating end #20</u></p>	<p>Coil contacts X1-X2 Crimp end to accommodate 05 911 00 AWG16-18-20 <u>Contact mating end #16</u></p>	<p>Coil contacts X1-X2 Crimp end to accommodate 05 910 01 AWG16-18-20 <u>Contact mating end #16</u></p>
Code 0 Without contacts	<p>Code 11 MIL-C-39029/92-535 30 976 00 Bin Code color bands or Bin Code numbering on crimpside Crimp end to accommodate AWG 12 <u>Contact mating end #12</u></p>	<p>Code 13 MIL-C-39029/92-536 31 099 00 Bin Code color bands or Bin Code numbering on crimpside Crimp end to accommodate AWG 16 <u>Contact mating end #12</u></p>
	<p>Coil contacts MIL-C-39029/92-533 X1-X2 Bin Code color bands or Bin Code numbering on crimpside 30 315 00 Crimp end to accommodate AWG16-18-20 <u>Contact mating end #16</u></p>	<p>Coil contacts MIL-C-39029/92-533 X1-X2 Bin Code color bands or Bin Code numbering on crimpside 30 315 00 Crimp end to accommodate AWG16-18-20 <u>Contact mating end #16</u></p>

**SOCKET NUMBERING SYSTEM**

**S500, S501, S502**

	S500	A	1	A	8
1-Basic socket designation_____					
2-Terminal Layout_____					
3-Mounting Hardware_____					
4-Grommet to seal on wire insulation_____					
5-Contact size and style_____					

**MS/LEACH CROSS PART NO. AND MATING RELAYS**

	MS - Number	LEACH P/N	Number Of Contacts	Hardware
<b>MIL-S-12883/48A</b>	-01	S500-A8A11	9xMIL-C-39029/92-535 2xMIL-C-39029/92-533	Loose Stud
	-02	S500-A9A11	9xMIL-C-39029/92-535 2xMIL-C-39029/92-533	Fixed Stud
	-05	S501-E8A11	9xMIL-C-39029/92-535 2xMIL-C-39029/92-533	Loose Stud
	-03	S501-E9A11	9xMIL-C-39029/92-535 2xMIL-C-39029/92-533	Fixed Stud