

**Surface mount Silicon-Zener Diodes
(planar technology)**
**Planare Si-Zener-Dioden
für die Oberflächenmontage**

Version 2005-01-18

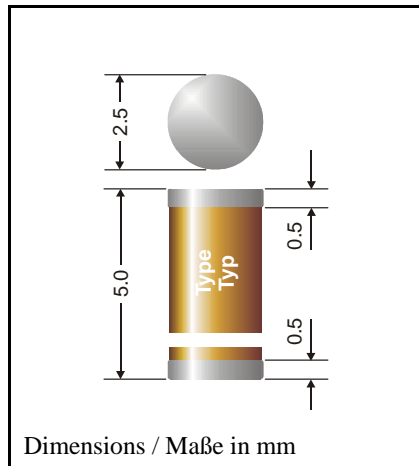

Maximum power dissipation Maximale Verlustleistung	1.0 W
Nominal Z-voltage Nominale Z-Spannung	1...100 V
Glass case MELF Glasgehäuse MELF	DO-213AB
Weight approx. Gewicht ca.	0.12 g
Standard packaging taped and reeled Standard Lieferform gegurtet auf Rolle	

Standard Zener voltage tolerance is graded to the international E 24 (~5%) standard.
Other voltage tolerances and higher Zener voltages on request.

Die Toleranz der Zener-Spannung ist in der Standard-Ausführung gestuft nach der internationalen Reihe E 24 (~5%). Andere Toleranzen oder höhere Arbeitsspannungen auf Anfrage.

Advantages of planar Zener-Diodes:
Low junction capacity
Low leakage current I_R

Vorteile der planaren Zener-Dioden:
Niedrige Sperrschichtkapazität
Niedriger Sperrstrom I_R

Maximum ratings and Characteristics
Grenz- und Kennwerte

Power dissipation – Verlustleistung	$T_A = 25^\circ\text{C}$	P_{tot}	1.0 W ¹⁾
Operating junction temperature – Sperrschichttemperatur		T_j	- 50...+175°C
Storage temperature – Lagerungstemperatur		T_s	- 50...+175°C
Thermal resistance junction to ambient air Wärmewiderstand Sperrschicht – umgebende Luft		R_{thA}	< 150 K/W ¹⁾

¹⁾ Mounted on P.C. board with 50 mm² copper pads at each terminal
Montage auf Leiterplatte mit 50 mm² Kupferbelag (Lötpad) an jedem Anschluß

²⁾ Tested with pulses – Gemessen mit Impulsen

³⁾ The ZMY1G is a diode operated in forward. Hence, the index of all parameters should be “F” instead of “Z”.
The cathode, indicated by a white ring is to be connected to the negative pole.

Die ZMY1G ist eine in Durchlaß betriebene Si-Diode. Daher ist bei allen Kenn- und Grenzwerten der Index “F” anstatt “Z” zu setzen. Die durch den weißen Ring gekennzeichnete Kathode ist mit dem Minuspol zu verbinden.

Maximum ratings
Grenzwerte

Type Typ	Zener voltage ²⁾ Zener-Spannung ²⁾ $I_Z = I_{Ztest}$ V_{zmin} [V] V_{zmax}		Test cur. Meß- strom I_{Ztest} [mA]	Dyn. resistance Diff. Widerst. $I_{Ztest} / 1 \text{ kHz}$ r_{zj} [Ω]	Temp. Coeffiz. of Z-voltage ...der Z-spanng. α_{vZ} [$10^{-4} / ^\circ\text{C}$]	Reverse volt. Sperrspanng. $I_R = 500 \text{ nA}$ V_R [V]	Z-current ¹⁾ Z-Strom ¹⁾ $T_A = 25^\circ\text{C}$ I_{Zmax} [mA]
ZMY1G ³⁾	0.65	0.75	5	6.5 (<8)	-26...-23	-	500
ZMY3.0G	2.8	3.2	100	5 (<8)	-8...+1	-	313
ZMY3.3G	3.1	3.5	100	5 (<8)	-8...+1	> 0.7 (150 μ A)	286
ZMY3.6G	3.4	3.8	100	5 (<8)	-8...+1	> 0.7 (100 μ A)	263
ZMY3.9G	3.7	4.1	100	4 (<7)	-7...+2	> 0.7 (100 μ A)	244
ZMY4.3G	4.0	4.6	100	4 (<7)	-7...+3	> 0.7 (50 μ A)	217
ZMY4.7G	4.4	5.0	100	4 (<7)	-7...+4	> 0.7 (10 μ A)	200
ZMY5.1G	4.8	5.4	100	2 (<5)	-6...+5	> 0.7 (10 μ A)	185
ZMY5.6G	5.2	6.0	100	1 (<2)	-3...+5	> 1.5	167
ZMY6.2G	5.8	6.6	100	1 (<2)	-1...+6	> 2	152
ZMY6.8G	6.4	7.2	100	1 (<2)	0...+7	> 3	139
ZMY7.5G	7.0	7.9	100	1 (<2)	0...+7	> 5	127
ZMY8.2G	7.7	8.7	100	1 (<2)	+3...+8	> 6	115
ZMY9.1G	8.5	9.6	50	2 (<4)	+3...+8	> 7	104
ZMY10G	9.4	10.6	50	2 (<4)	+5...+9	> 7.5	94
ZMY11G	10.4	11.6	50	3 (<7)	+5...+10	> 8.5	86
ZMY12G	11.4	12.7	50	3 (<7)	+5...+10	> 9	79
ZMY13G	12.4	14.1	50	4 (<9)	+5...+10	> 10	709
ZMY15G	13.8	15.6	50	4 (<9)	+5...+10	> 11	64
ZMY16G	15.3	17.1	25	5 (<10)	+7...+11	> 12	58
ZMY18G	16.8	19.1	25	5 (<11)	+7...+11	> 14	52
ZMY20G	18.8	21.2	25	6 (<12)	+7...+11	> 15	47
ZMY22G	20.8	23.3	25	7 (<13)	+7...+11	> 17	43
ZMY24G	22.8	25.6	25	8 (<14)	+7...+12	> 18	39
ZMY27G	25.1	28.9	25	9 (<15)	+7...+12	> 20	35
ZMY30G	28	32	25	10 (<20)	+7...+12	> 22.5	31
ZMY33G	31	35	25	11 (<20)	+7...+12	> 25	29
ZMY36G	34	38	10	25 (<60)	+7...+12	> 27	26
ZMY39G	37	41	10	30 (<60)	+8...+12	> 29	24
ZMY43G	40	46	10	35 (<80)	+8...+13	> 32	22
ZMY47G	44	50	10	40 (<80)	+8...+13	> 35	20
ZMY51G	48	54	10	45 (<100)	+8...+13	> 38	19
ZMY56G	52	60	10	50 (<100)	+8...+13	> 42	17
ZMY62G	58	66	10	60 (<130)	+8...+13	> 47	15
ZMY68G	64	72	10	65 (<130)	+8...+13	> 51	14
ZMY75G	70	79	10	70 (<160)	+8...+13	> 56	13
ZMY82G	77	88	10	80 (<160)	+8...+13	> 61	11
ZMY91G	85	96	5	120 (<250)	+9...+13	> 68	10
ZMY100G	94	106	5	130 (<250)	+9...+13	> 75	9

¹⁾ Notes see previous page – Fußnoten siehe vorhergehende Seite

